



Ai-M62-32S Specification

Version V1.0.1

Copyright ©2023

Content

1. Product overview	4
1.1. Characteristics	5
2. Main parameters	6
2.1. Electrostatic requirements	6
2.2. Electrical characteristics	7
2.3. Wi-Fi radio frequency performance	7
2.4. BLE RF performance	8
2.5. Power consumption	8
3. Appearance size	9
4. Pin definition	10
5. Schematic diagram	13
6. Antenna parameters	14
6.1. Schematic of Antenna Test Prototype	14
6.2. Antenna s parameter	15
6.3. Antenna Gain and Efficiency	15
6.4. Antenna field pattern	16
7. Design guidance	17
7.1. Application guidance circuit	17
7.2. Recommended PCB package size	18
7.3. Antenna layout requirements	18
7.4. Power supply	19
7.5. GPIO	20
8. Storage conditions	21
9. Reflow Soldering Curve	21
10. Product packaging information	22
11. Contact us	22
Disclaimer and copyright notice	23
Notice	23
Statement	24

1. Product overview

Ai-M62-32S is a Wi-Fi 6 + BLE5.3 module developed by Shenzhen Ai-Thinker Technology Co., Ltd. The module is equipped with BL616 chip as the core processor, supports Wi-Fi 802.11b/g/n/ax protocol and BLE protocol, and supports Thread protocol. The BL616 system includes a low-power 32-bit RISC-V CPU with floating-point unit, DSP unit, cache and memory, with a maximum dominant frequency of 320M.

The Ai-M62-32S module has rich peripheral interfaces, including USB2.0, SDU, SD / MMC (SDH), SPI, UART, I2C, I2S, PWM, GPDAC, GPADC, ACOMP and GPIO, etc. It can be widely used in audio and video multimedia, Internet of Things (IoT), mobile devices, wearable electronic devices, smart homes and other fields.

The Ai-M62-32S module Sec Eng module supports AES/SHA/PKA/TRNG and other functions, supports image encryption and signature startup, and meets various security application requirements in the Internet of Things field.

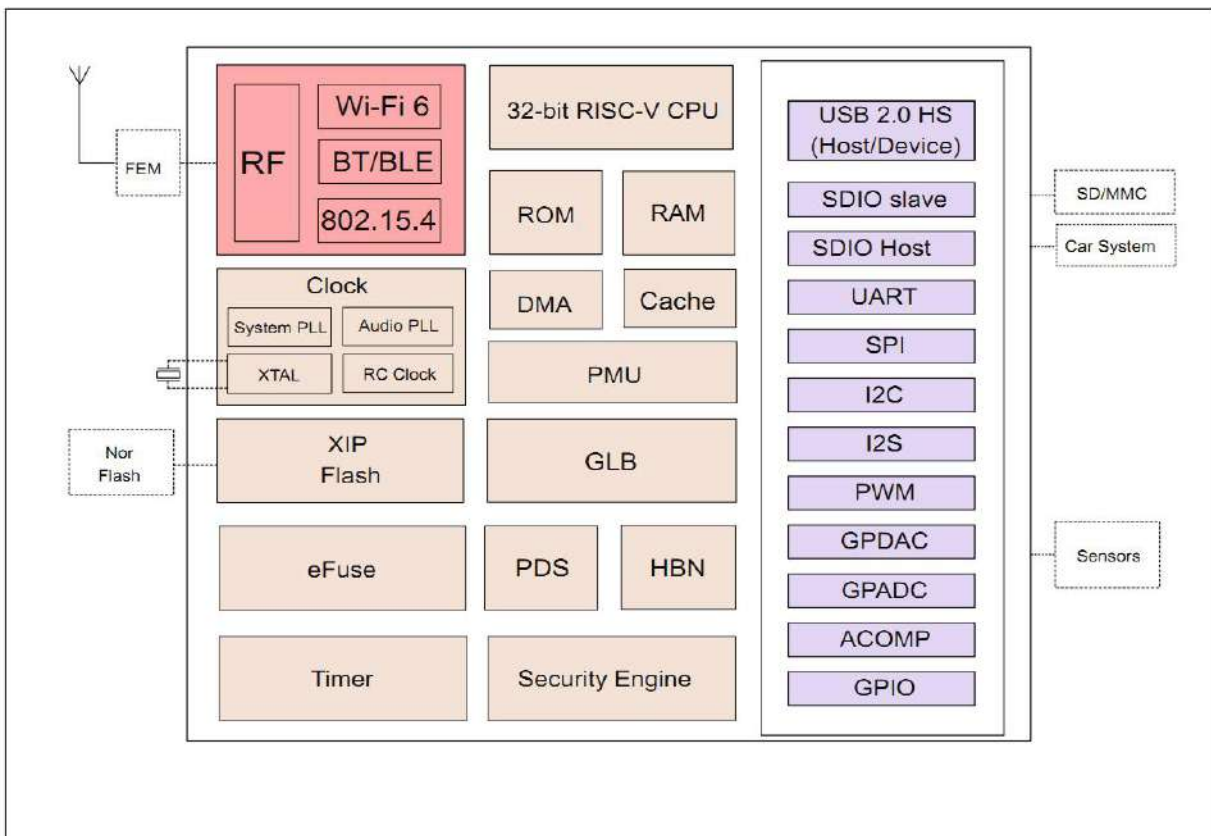

Figure 1 Main chip architecture diagram

1.1. Characteristics

- SMD-38 package
- Supports 2.4GHz operating frequency band
- Support IEEE 802.11 B/g/n/ax
- Support BLE5.3
- Support Thread
- Support Wi-Fi/BLE/Thread coexistence
- Wi-Fi security support WPS/WEP/WPA/WPA2/WPA3
- Supports 20/40MHz bandwidth, 1T1R, maximum rate 229.4 Mbps
- Support STA, SoftAP, STA + SoftAP and sniffer modes
- 32-bit RISC-V CPU with FPU and DSP, with a maximum dominant frequency of 320M
- 532KB SRAM,128KB ROM,4Kb eFuse
- Support USB2.0, SDU, SD / MMC (SDH), SPI, UART, I2C, I2S, PWM, GPDAC, GPADC, ACOMP and GPIO, etc
- Integrated RF Balun, PA/LNA
- Support for safe startup and safe debugging
- Support XIP QSPI On-The-Fly AES decryption (OTFAD)
- Support TrustZone
- Support AES-CBC/CCM/GCM/XTS mode
- Support MD5, SHA-1/224/256/384/512
- TRNG (True Random Number Generator) is supported
- Support PKA (Public Key Accelerator) for RSA/ECC
- BLE-enabled Wi-Fi fast connection
- Universal AT command can be used quickly.
- Supports secondary development and integrates Windows and Linux development environments

2. Main parameters

Table 1 Description of Main Parameters

Model	Ai-M62-32S
Package	SMD-38
Size	25.5*18.0*3.1(±0.2)mm
Antenna	Onboard antenna/IPEX seat
Frequency	2400~2483.5MHz
Operating temperature	-40 °C ~ 85 °C
Storage temperature	-40°C ~ 125°C, < 90%RH
Power supply	The power supply voltage is 2.97V ~ 3.6V, and the power supply current is ≥ 500mA.
Interface	USB2.0, SDU, SD / MMC (SDH), SPI, UART, I2C, I2S, PWM, GPDAC, GPADC, ACOMP and GPIO, etc
IO	18
UART rate	Default 115200 bps
Security	WPS/WEP/WPA/WPA2/WPA3
Flash	Default 4MByte, maximum support of 16MByte

2.1. Electrostatic requirements

Ai-M62-32S are electrostatic sensitive equipment, special precautions need to be taken when handling.



Figure 2 ESD preventive measures

2.2. Electrical characteristics

Table 2 Table of Electrical Characteristics

Parameters	Conditio	Min.	Typical value	Max.	Unit
Supply voltage	VDD	2.97	3.3	3.6	V
I/O	VIL	-	-	0.3*VDDIO	V
	VIH	-	0.7*VDDIO	-	V
	VOL	-	-	0.1*VDDIO	V
	VOH	-	-	0.9*VDDIO	V
	IMAX	-	-	-	15

2.3. Wi-Fi radio frequency performance

Table 3 Wi-Fi RF performance table

Description	Typical value			Unit
Spectrum range	2400~2483.5MHz			MHz
Output power				
Mode	Min.	Typical	Max.	Unit
11ax mode HE40,PA output power	-	16	-	dBm
11ax mode HE20,PA output power	-	17	-	dBm
11n mode HT40,PA output power	-	19	-	dBm
11n mode HT20,PA output power	-	19	-	dBm
In 11g mode, PA output power	-	19	-	dBm
In 11b mode, PA output power	-	22	-	dBm
Receiving sensitivity				
Mode	Min.	Typical	Max.	Unit
11b,1 Mbps	-	-98	-	dBm
11b,11 Mbps	-	-90	-	dBm
11g,6 Mbps	-	-93	-	dBm
11g,54 Mbps	-	-76	-	dBm
11n,HT20 (MCS7)	-	-73	-	dBm
11ax,HE20 (MCS9)	-	-70	-	dBm
11ax,HE40 (MCS9)	-	-67	-	dBm

2.4. BLE RF performance

Table 4 BLE RF Performance Table

Description	Typical value			Unit
Spectrum range	2400~2483.5MHz			MHz
Output power				
Mode	Min.	Typical value	Max.	Unit
1Mbps	-	10	15	dBm
2Mbps	-	10	15	dBm
Receiving sensitivity				
Mode	Min.	Typical value	Max.	Unit
1Mbps sensitivity @ 30.8%PER	-	-99	-	dBm
2Mbps sensitivity @ 30.8%PER	-	-97	-	dBm

2.5. Power consumption

The following power consumption data is based on a 3.3V power supply and measured at an ambient temperature of 25°C.

- The POUT power for all transmit modes is the measured value at the antenna interface.
- All transmission data are measured in the continuous transmission mode based on a duty cycle of 100%.

Table 5 Power consumption table

Mode	Min.	Average	Max.	Unit
Transmit 802.11B, 11Mbps, POUT = + 22dBm	-	423	-	mA
Transmit 802.11g, 54Mbps, POUT = + 19dBm	-	331	-	mA
Emission 802.11n, MCS7, POUT = + 19dBm	-	328	-	mA
Launch 802.11ax, MCS7, POUT = + 17dBm	-	293	-	mA
Receive 802.11B, packet length 1024 bytes	-	59	-	mA
Receive 802.11g, packet length 1024 bytes	-	59	-	mA
Receive 802.11n, packet length 1024 bytes	-	59	-	mA
Receive 802.11ax, packet length 1024 bytes	-	59	-	mA

3. Appearance size



Figure 3 appearance diagram (Rendering diagram is for reference only, subject to actual objects)

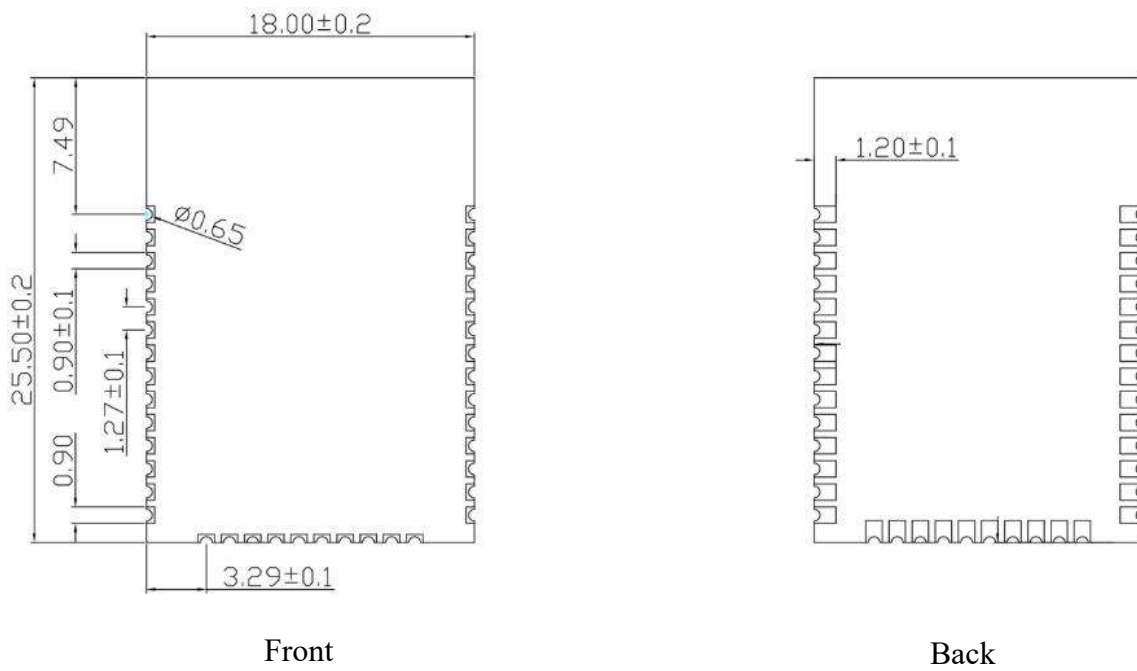

Figure 4 dimension diagram

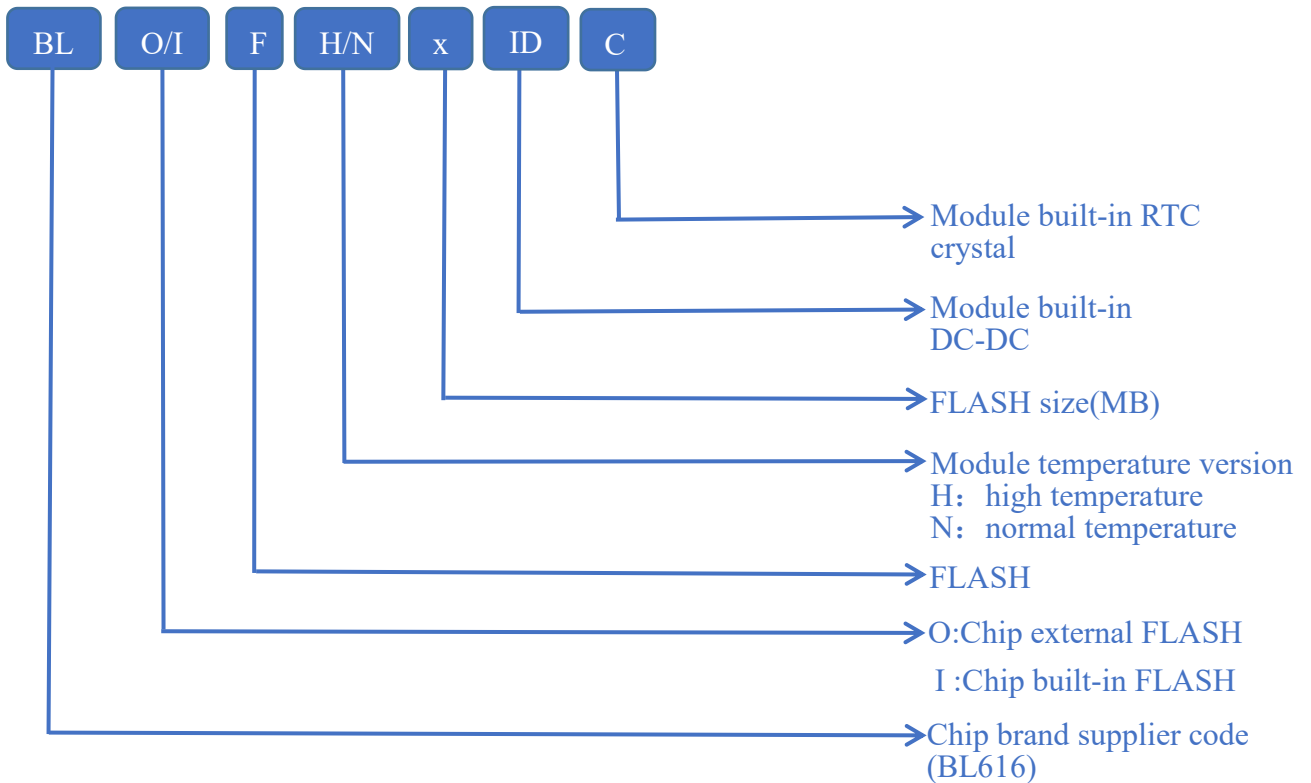

Figure 5 screen printing representative information of shield

4. Pin definition

A total of 38 pins are connected to the Ai-M62-32S module, as shown in the pin diagram, the pin function definition table is an interface definition.

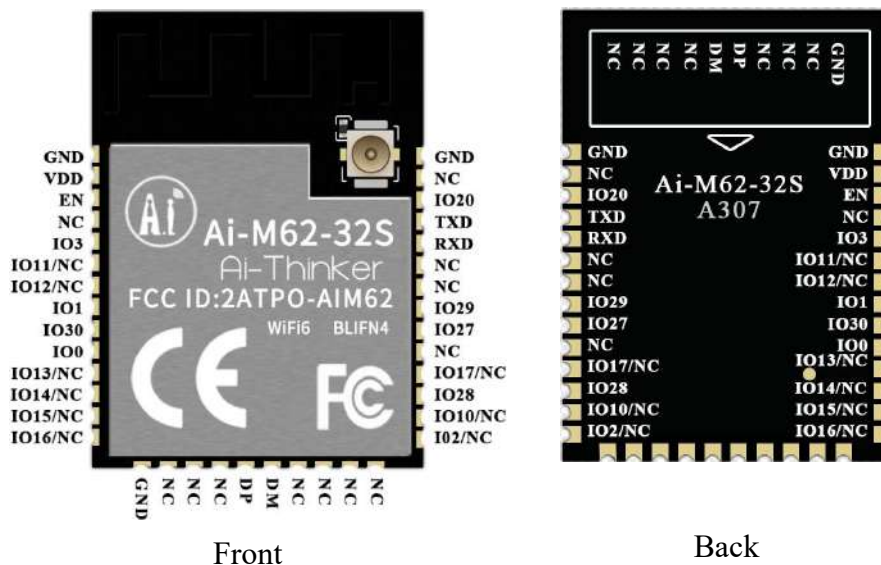

Figure 6 pin diagram

Table 6 Pin Function Definition Table

Foot	Name	Functional description
1,15,38	GND	Grounding
2	VDD	3.3V power supply; The output current of external power supply is recommended to be above 500mA.
3	EN	Default as chip enable, high level valid
4,16,17,18,21,22,23,24,29,32,33,37	NC	NC is not available
5	IO3	GPIO3/SPI_MOSI/I2S_DO/I2S_RCLK_O/I2C_SDA/ADC_CH3/PWM0
6	IO11/NC	Available by default, this IO port is shared with Flash in the module. If a module with external Flash is customized, the IO is not available. For use, please contact Ai-Thinker. GPIO11/SPI_MOSI/I2S_DO/I2S_RCLK_O/I2C_SDA/PWM0
7	IO12/NC	Available by default, this IO port is shared with Flash in the module. If a module with external Flash is customized, the IO is not available. For use, please contact Ai-Thinker.
8	IO1	GPIO1/SPI_SCLK/I2S_FS/I2C_SDA/ADC_CH8/PWM0
9	IO30	GPIO30/SPI_MISO/I2S_DI/I2S_RCLK_O/I2C_SCL/PWM0
10	IO0	GPIO0/SPI_SS/I2S_BCLK/I2C_SCL/ADC_CH9/PWM0
11	IO13/NC	Available by default, this IO port is shared with Flash in the module. If a module with external Flash is customized, the IO is not available. For use, please contact Ai-Thinker. GPIO13/SPI_SCLK/I2S_FS/I2C_SDA/ADC_CH5/PWM0
12	IO14/NC	Available by default, this IO port is shared with Flash in the module. If a module with external Flash is customized, the IO is not available. For use, please contact Ai-Thinker. GPIO14/SPI_MISO/I2S_DI/I2S_RCLK_O/I2C_SCL/ADC_CH4/PWM0
13	IO15/NC	Available by default, this IO port is shared with Flash in the module. If a module with external Flash is customized, the IO is not available. For use, please contact Ai-Thinker. GPIO15/SPI_MOSI/I2S_DO/I2S_RCLK_O/I2C_SDA/PWM0

14	IO16/NC	Available by default, the IO port is shared with the PIN pin of the 32.768KHz crystal oscillator input inside the module. If the module of the internal patch 32.768KHz crystal oscillator is customized, the IO is in NC state. GPIO16/SPI_SS/I2S_BCLK/I2C_SCL/XTAL_32K_IN/PWM0
19	DP	USB_DP
20	DM	USB_DM
25	IO2/NC	The default NC is not available. If you need to use it, please contact Ai-Thinker. If elicited, support Bootstrap/GPIO2/SPI_MISO/I2S_DI/I2S_RCLK_O/I2C_SCL/ADC_CH2/PWM0
26	IO10/NC	Available by default, this IO port is shared with Flash in the module. If a module with external Flash is customized, the IO is not available. For use, please contact Ai-Thinker. GPIO10/SPI_MISO/I2S_DI/I2S_RCLK_O/I2C_SCL/ADC_CH7/PWM0
27	IO28	GPIO28/SPI_SS/I2S_BCLK/I2C_SCL/ADC_CH11/PWM0
28	IO17/NC	Available by default, the IO port is shared with the 32.768KHz crystal output PIN pin inside the module. If the module of the internal patch 32.768KHz crystal oscillator is customized, the IO is in NC state. GPIO17/SPI_SCLK/I2S_FS/I2C_SDA/XTAL_32K_OUT/PWM0
30	IO27	GPIO27/SPI_MOSI/I2S_DO/I2S_RCLK_O/I2C_SDA/ADC_CH10/PWM0
31	IO29	GPIO29/SPI_SCLK/I2S_FS/I2C_SDA/PWM0
34	RXD	RXD/GPIO22/SPI_MISO/I2S_DI/I2S_RCLK_O/I2C_SCL/PWM0
35	TXD	TXD/GPIO21/SPI_SCLK/I2S_FS/I2C_SDA/ADC_RCAL_VOUT/PWM0
36	IO20	GPIO20/SPI_SS/I2S_BCLK/I2C_SCL/ADC_CH0/PWM0

Note: 1. GPIO2 is used as a Bootstrap. When the power-on moment is high, the module enters the burning mode. When the power-on moment is low, the module starts normally.

5. Schematic diagram

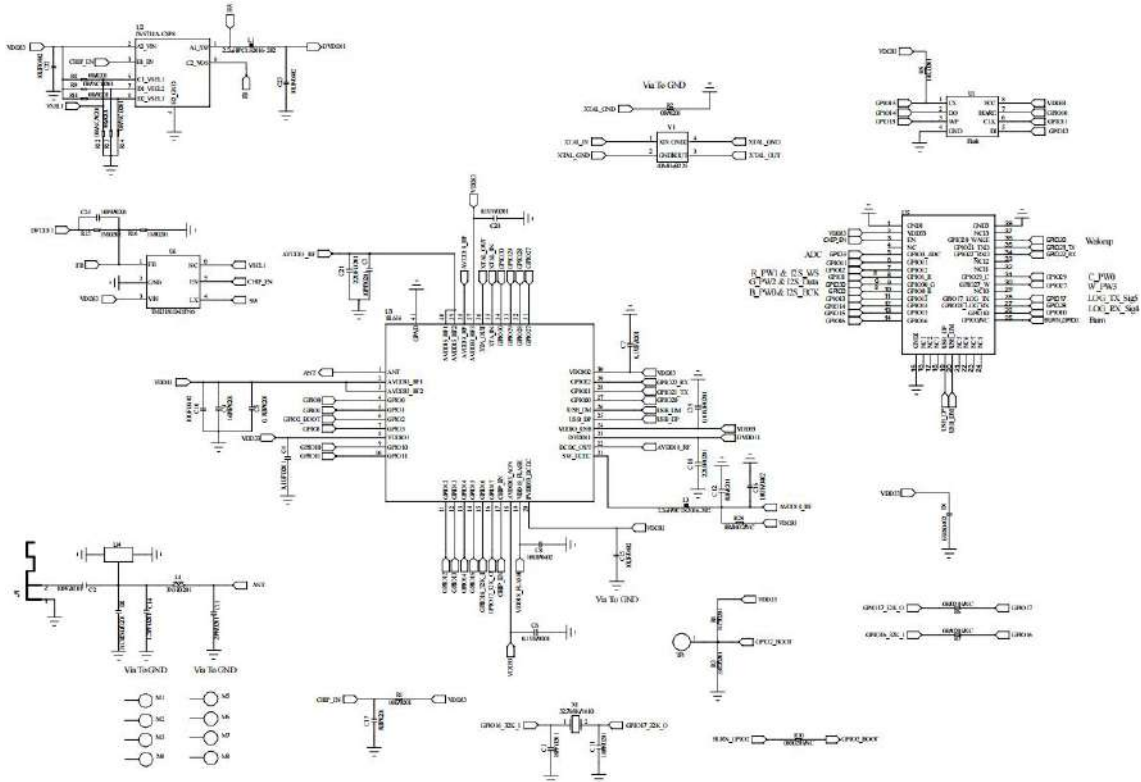

Figure 7 Schematic Diagram

6. Antenna parameters

6.1. Schematic of Antenna Test Prototype

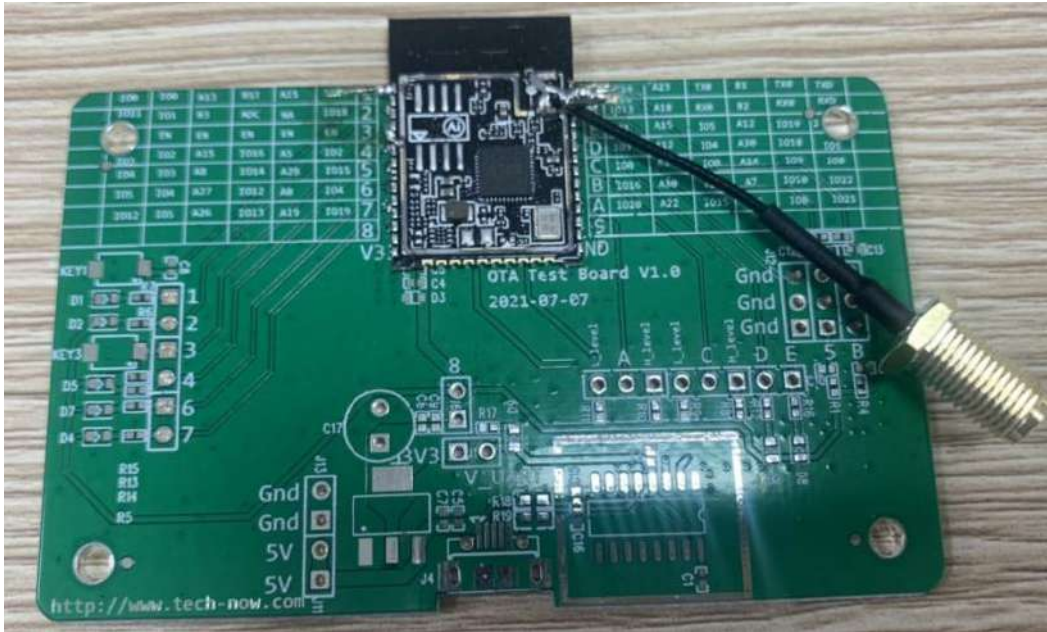

Figure 8 schematic diagram of antenna test prototype

6.2. Antenna s parameter

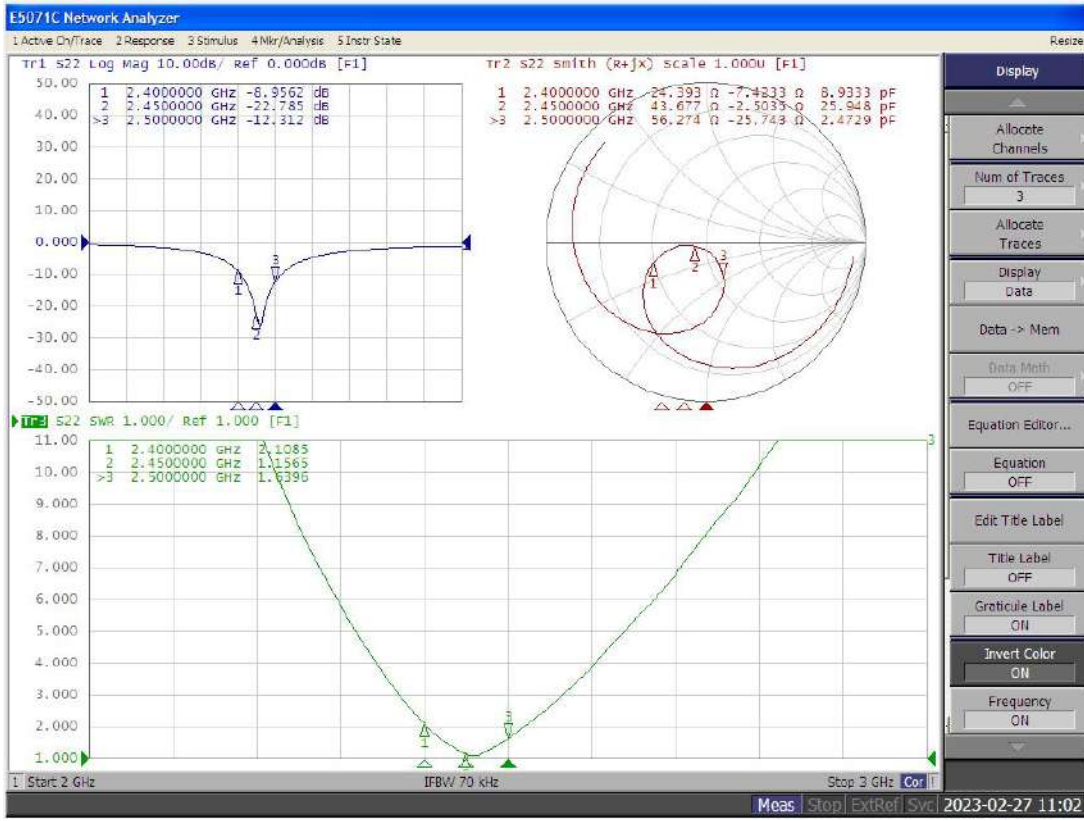

Figure 9 antenna s parameters

6.3. Antenna Gain and Efficiency

Table 7 Antenna Gain and Efficiency

Frequency ID	1	2	3	4	5	6	7	8	9	10	11
Frequency(MHz)	2400	2410	2420	2430	2440	2450	2460	2470	2480	2490	2500
Gain (dBi)	1.04	1.26	1.42	1.52	1.67	1.76	1.89	1.90	1.50	1.40	1.30
Efficiency (%)	53.34	55.78	57.93	59.05	60.96	62.73	63.90	63.74	60.33	59.98	57.86

6.4. Antenna field pattern

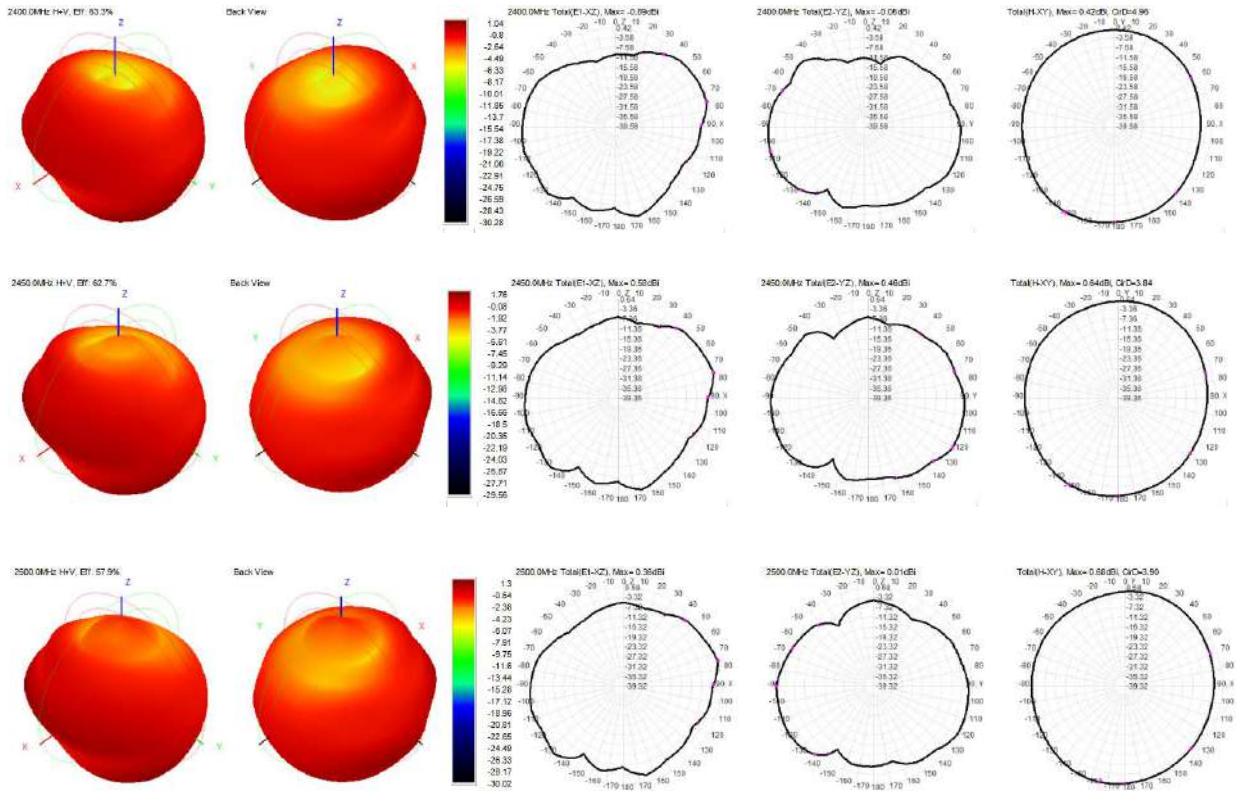

Figure 10 antenna field diagram

7. Design guidance

7.1. Application guidance circuit

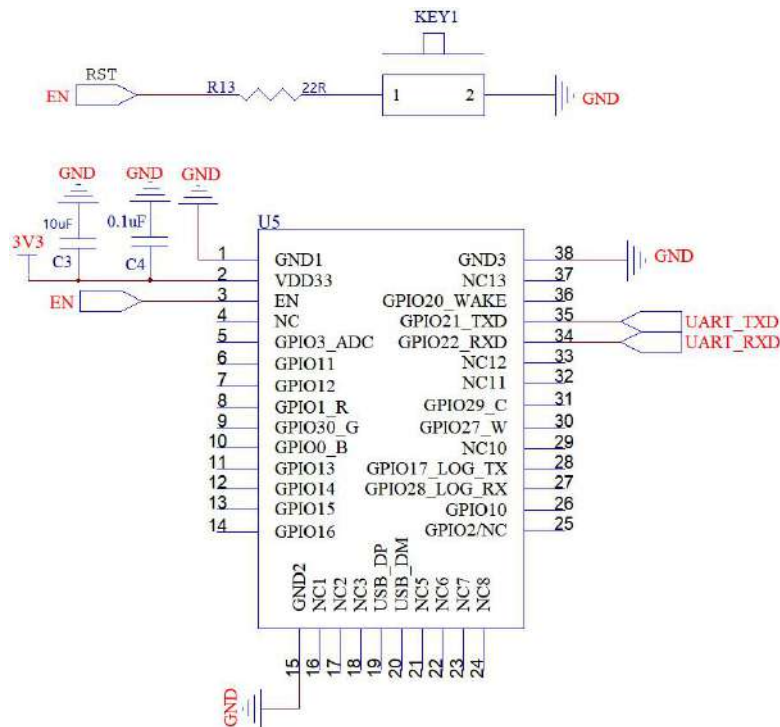

Figure 11 Application Guidance Circuit

- IO2 is the module start control pin, which is in normal working mode at low level and in firmware burning mode at high level. The default low level inside the chip.
- GPIO2/NC, not available by default
- GPIO10/GPIO11/GPIO12/GPIO13/GPIO14/GPIO15, available by default. These IO ports are shared with the internal Flash of the module. If the module with external Flash is customized, it cannot be used. For use, please contact Ai-Thinker.
- GPIO16/GPIO17, available by default. These IO ports are shared with the PIN pin of the 32.768KHz crystal oscillator inside the module. If the module of the internal patch 32.768KHz crystal oscillator is customized, the IO is in NC state.

7.2. Recommended PCB package size

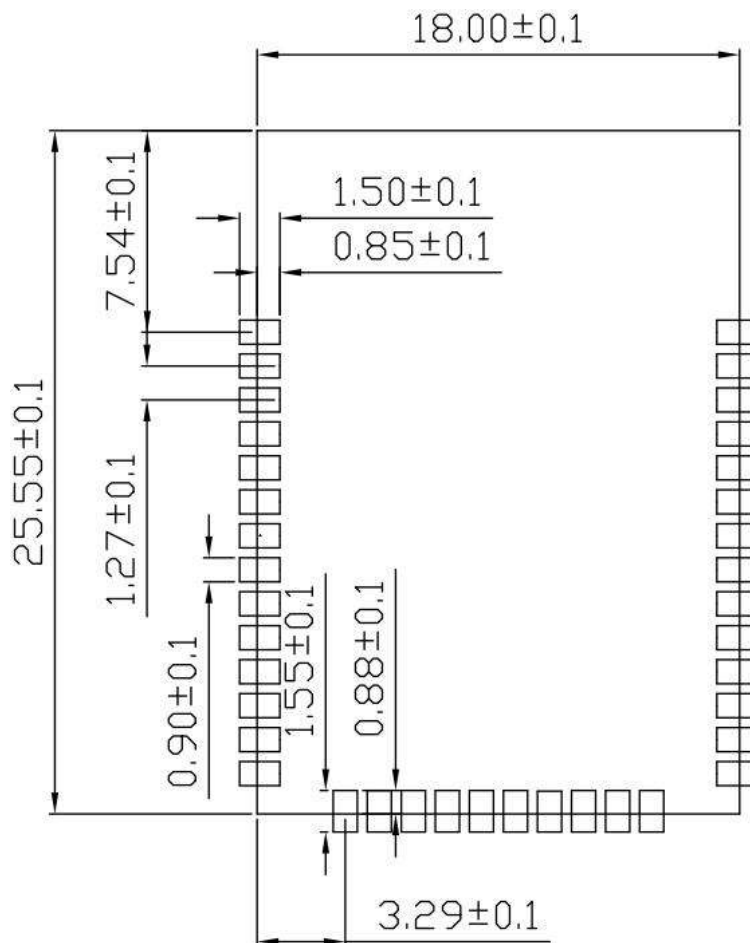

Figure 12 Recommended PCB Package Size

7.3. Antenna layout requirements

■ In the installation position on the motherboard, the following 2 methods are recommended:

Scheme 1: Place the module on the edge of the main board, and the antenna area extends out of the edge of the main board.

Scheme 2: Place the module on the edge of the motherboard, and the edge of the motherboard hollowed out an area at the antenna position.

■ In order to meet the performance of the on-board antenna, it is forbidden to place metal parts around the antenna, away from high-frequency devices.

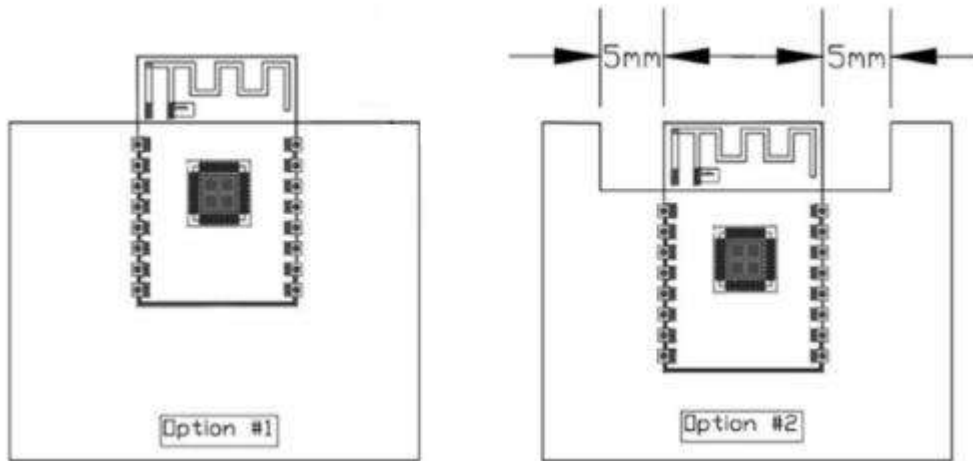

Figure 13 schematic diagram of antenna layout

7.4. Power supply

- Recommended 3.3V voltage, peak current above 500mA.
- LDO is recommended for power supply; If DC-DC is used, it is recommended that the ripple be controlled within 30mV.
- The DC-DC power supply circuit suggests to reserve the position of the dynamic response capacitor, which can optimize the output ripple when the load changes greatly.
- It is recommended to add ESD devices to the 3.3V power interface.

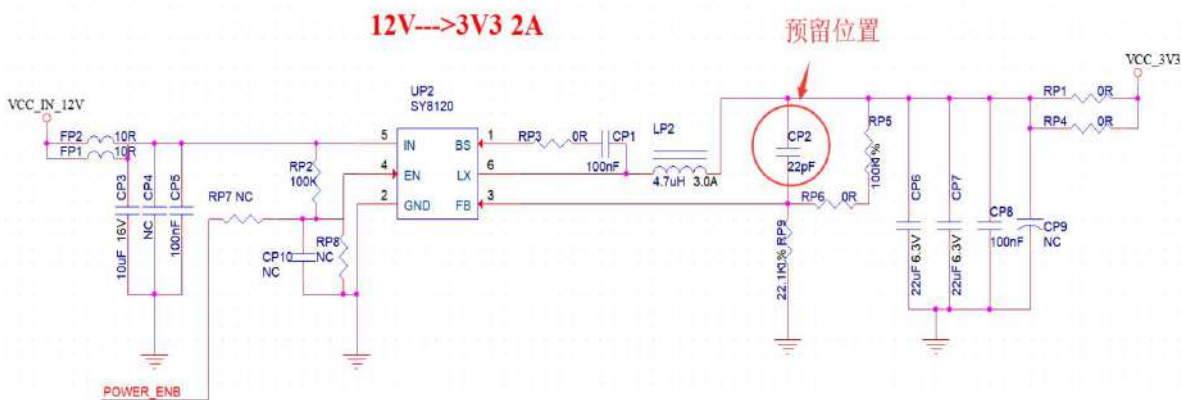

Figure 14 DC-DC step-down circuit diagram

7.5. GPIO

- Some IO ports are led out from the periphery of the module. If you need to use a resistor of 10-100 ohms in series on the IO port. This can suppress overshoot and make the level on both sides more stable. It is helpful for both EMI and ESD.
- For the up and down of the special IO port, please refer to the instructions in the specification, which will affect the startup configuration of the module.
- The IO port of the module is 3.3V. If the level of the IO port of the main control and the module does not match, a level conversion circuit needs to be added.
- If the IO port is directly connected to the peripheral interface or terminals such as pins, it is recommended to reserve ESD devices at the IO port wiring close to the terminals.

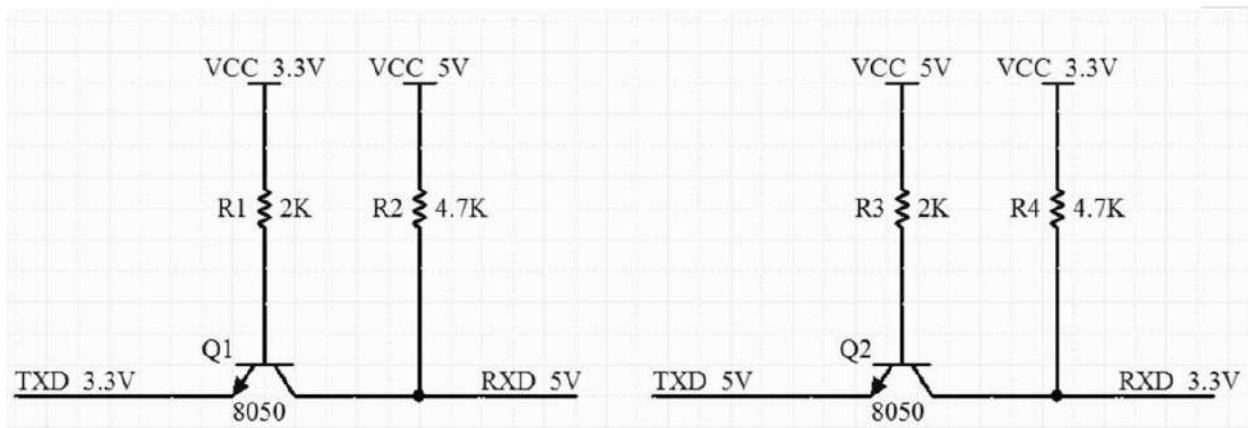

Figure 15 Level Shift Circuit

8. Storage conditions

The product sealed in the moisture-proof bag should be stored in a non-condensing atmospheric environment of <math> < 40^{\circ}\text{C}/90\%\text{RH}</math>.

The moisture sensitivity level MSL of the module is level 3.

After the vacuum bag is unpacked, it must be used within 168 hours at $25 \pm 5^{\circ}\text{C}/60\%\text{RH}$, otherwise it needs to be baked before it can be put on line again.

9. Reflow Soldering Curve

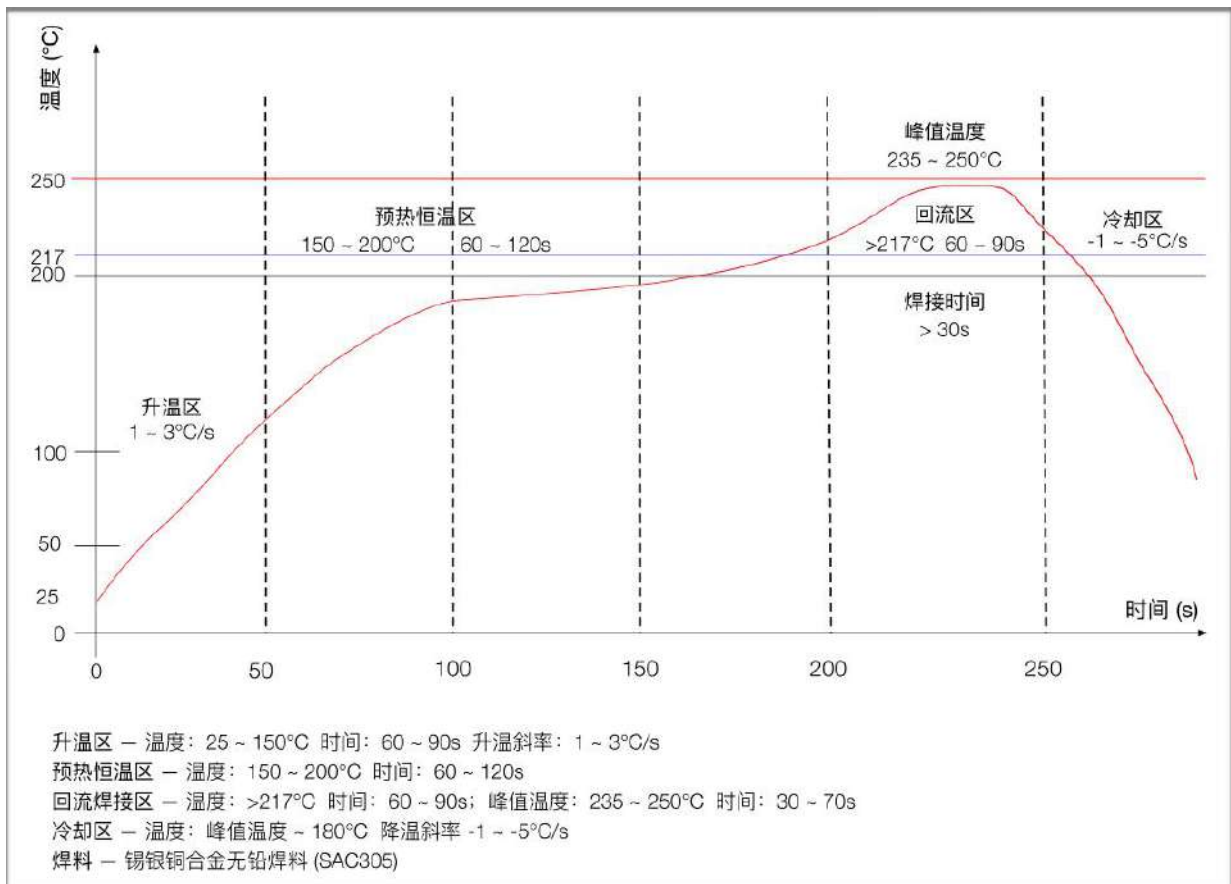

Figure 16 reflow soldering graph

10. Product packaging information

The Ai-M62-32S module is packaged with braided tape, 800 pcs/disk. As shown in the following figure:



Figure 17 packing tape drawing

11. Contact us

[Ai-Thinker official website](#)

[Office forum](#)

[Develop DOCS](#)

[LinkedIn](#)

[Tmall shop](#)

[Taobao shop](#)

[Alibaba shop](#)

[Technical support email: support@aithinker.com](mailto:support@aithinker.com)

[Domestic business cooperation: sales@aithinker.com](mailto:sales@aithinker.com)

[Overseas business cooperation: overseas@aithinker.com](mailto:overseas@aithinker.com)

Company Address: Room 403-405,408-410, Block C, Huafeng Smart Innovation Port, Gushu 2nd Road, Xixiang, Baoan District, Shenzhen.

Tel: +86-0755-29162996



WeChat mini program



WeChat official account

Disclaimer and copyright notice

The information in this article, including the URL address for reference, is subject to change without notice.

The document is provided "as is" without any guarantee responsibility, including any guarantee for merchantability, suitability for a specific purpose, or non-infringement, and any guarantee mentioned elsewhere in any proposal, specification or sample. This document does not bear any responsibility, including the responsibility for infringement of any patent rights arising from the use of the information in this document. This document does not grant any license for the use of intellectual property rights in estoppel or other ways, whether express or implied.

The test data obtained in the article are all obtained from Ai-Thinker's laboratory tests, and the actual results may vary slightly.

All brand names, trademarks and registered trademarks mentioned in this article are the property of their respective owners, and it is hereby declared.

The final interpretation right belongs to Shenzhen Ai-Thinker Technology Co., Ltd.

Notice

Due to product version upgrades or other reasons, the contents of this manual may be changed.

Shenzhen Ai-Thinker Technology Co., Ltd. reserves the right to modify the contents of this manual without any notice or prompt.

This manual is only used as a guide. Shenzhen Ai-Thinker Technology Co., Ltd. makes every effort to provide accurate information in this manual. However, Shenzhen Ai-Thinker Technology Co., Ltd. does not guarantee that the contents of the manual are completely free of errors. All statements and information in this manual And the suggestion does not constitute any express or implied guarantee.

Statement

Ai-Thinker may provide technical and reliability data (including data sheets), design resources (including reference designs), application or other design recommendations, network tools, safety information and other resources (the "Resources") "as is" without warranties of any kind, express or implied. Including, but not limited to, express or implied warranties of suitability, fitness for a particular use, or non-infringement of any third party's intellectual property rights. And specifically declares that it is not liable for any necessary or incidental losses, including but not limited to, arising from the application or the use of any of our products and circuits.

Ai-Thinker reserves the right to release information in this document (including but not limited to metrics and product descriptions) and any changes to our products without prior notice. This document automatically supersedes and replaces all information provided in previous versions of the same document number file.

These resources are available to skilled developers who design with Ai-Thinker products. You are solely responsible for: (1) Selecting the appropriate Ai-Thinker products for your application; (2) Design, validate, and run your application and product throughout its life cycle; (3) Ensure that your application meets all applicable standards, codes and laws, as well as any other functional security, information security, regulatory or other requirements.

Ai-Thinker may authorize you to use these resources only for the development of applications of Essence Products described in this Resource. Without the permission of Ai-Thinker, any unit or individual shall not extract or copy part or all of these resources, and shall not be transmitted in any form. You are not entitled to use any other Ai-Thinker intellectual property rights or any third party intellectual property rights. You shall indemnify you in full for any claims, damages, costs, losses and liabilities arising against Ai-Thinker or its representatives in connection with the use of these resources, for which Ai-Thinker is not liable.

The products offered by Ai-Thinker are subject to the terms of sale of Ai-Thinker or other applicable terms attached to Essence's products. Essence's availability of these resources does not extend or otherwise change the warranties or warranties disclaimers applicable to product releases.