



Ai-M62-13 Specification

Version V1.0.0

Copyright ©2023

Content

1. Product Overview	4
1.1. Characteristics	5
2. Main parameters	6
2.1. Static electricity requirement	6
2.2. Electrical characteristics	7
2.3. Wi-Fi RF Performance	7
2.4. BLE RF Performance	8
2.5. Power	8
3. Appearance Dimensions	9
4. Pin Definition	10
5. Schematic	12
6. Antenna parameters	13
6.1. Schematic diagram of the antenna test prototype	13
6.2. Antenna S parameter	14
6.3. Antenna Gain and Efficiency	14
6.4. Antenna pattern	15
7. Design Guidance	16
7.1. Module application circuit	16
7.2. Recommend PCB footprint size	17
7.3. Antenna layout requirements	17
7.4. Power supply	18
7.5. GPIO	19
8. Storage conditions	20
9. Reflow welding curve diagram	20
10. Product Packaging Information	21
11. Contact us	21
Disclaimer and copyright notice	22
Notice	22

1. Product Overview

Ai-M62-13 is a Wi-Fi 6 + BLE5.3 module developed by Shenzhen Ai-Thinker Technology Co., Ltd. The module is equipped with BL616 chip as the core processor, supports Wi-Fi 802.11b/g/n/ax protocol and BLE protocol, and supports Thread protocol. The BL616 system includes a low-power 32-bit RISC-V CPU with floating-point unit, DSP unit, cache and memory, with a maximum dominant frequency of 320M.

The Ai-M62-13 module has rich peripheral interfaces, including Audio Codec, USB2.0, SDU, SD/MMC(SDH), SPI, UART, I2C, I2S, PWM, GPDAC, GPDC, ACOMP, GPIO, etc. It can be widely used in audio and video multimedia, Internet of Things (IoT), mobile devices, wearable electronic devices, smart homes and other fields.

The Ai-M62-13 module Sec Eng module supports AES/SHA/PKA/TRNG and other functions, supports image encryption and signature startup, and meets various security application requirements in the Internet of Things field.

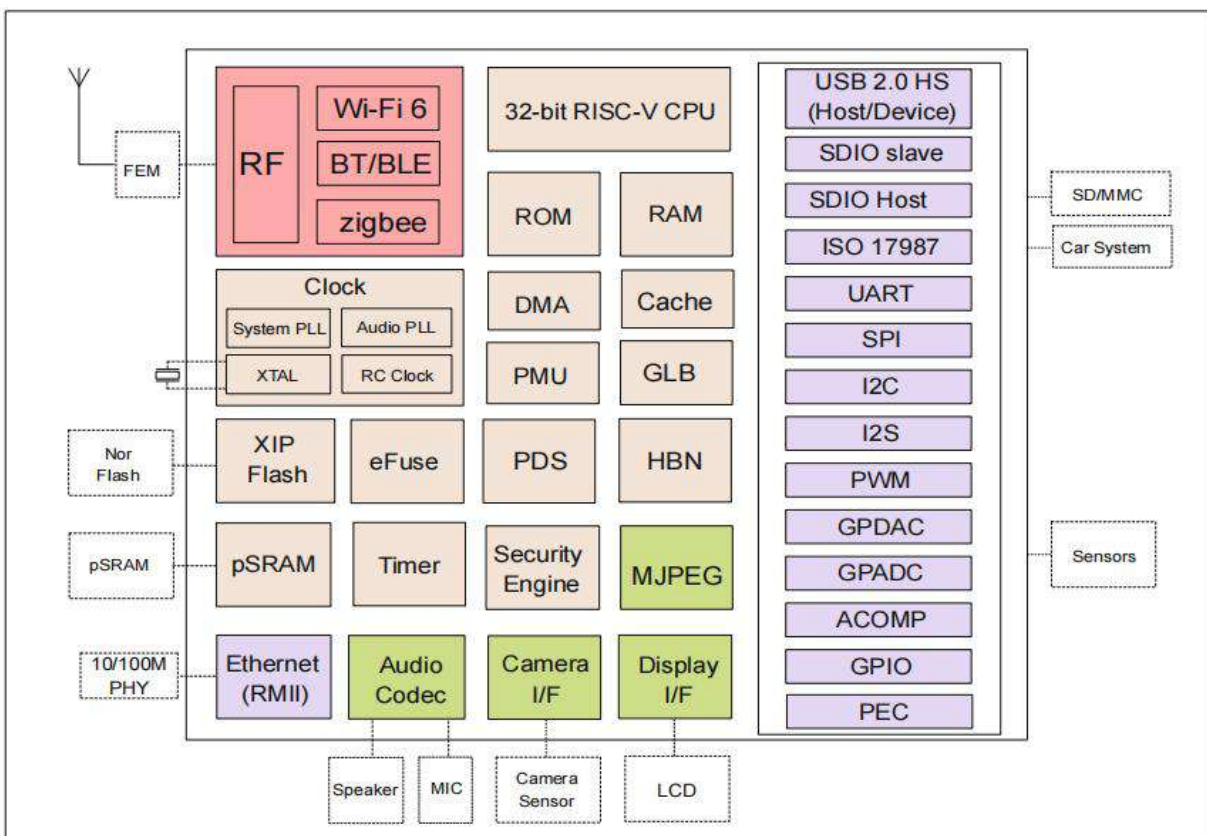

Figure 1 Main chip architecture diagram

1.1. Characteristics

- SMD-18 package
- Supports 2.4GHz operating frequency band
- Support IEEE 802.11 B/g/n/ax
- Support BLE5.3
- Support Thread
- Support Wi-Fi/BLE/Thread coexistence
- Wi-Fi security support WPS/WEP/WPA/WPA2/WPA3
- Supports 20/40MHz bandwidth, 1T1R, maximum rate 229.4 Mbps
- Support STA, SoftAP, STA + SoftAP and sniffer modes
- 32-bit RISC-V CPU with FPU and DSP, with a maximum dominant frequency of 320M
- 532KB SRAM,128KB ROM,4Kb eFuse
- Support Audio Codec, USB2.0, SDU, SD/MMC(SDH), SPI, UART, I2C, I2S, PWM, GPDAC, GPDC, ACOMP, GPIO, etc.
- Integrated RF Balun, PA/LNA
- Support for safe startup and safe debugging
- Support XIP QSPI On-The-Fly AES decryption (OTFAD)
- Support TrustZone
- Support AES-CBC/CCM/GCM/XTS mode
- Support MD5, SHA-1/224/256/384/512
- TRNG (True Random Number Generator) is supported
- Support PKA (Public Key Accelerator) for RSA/ECC
- BLE-enabled Wi-Fi fast connection
- Universal AT command can be used quickly.
- Supports secondary development and integrates Windows and Linux development environments

2. Main parameters

Table 1 Description of the main parameters

Model	Ai-M62-13
Package	SMD-18
Size	20*18.0*3.2(±0.2)mm
Antenna	on-board PCB antenna
Frequency	2400 ~ 2483.5MHz
Operating temperature	-40°C ~ 85°C
Storage temperature	-40°C ~ 125°C, < 90%RH
Power supply	Support voltage 2.97V ~ 3.6V, supply current ≥500mA
Interface	Audio Codec, USB2.0, SDU, SD/MMC(SDH), SPI, UART, I2C, I2S, PWM, GPDAC, GPADC, ACOMP, GPIO and so on
IO	11
UART rate	Default 115200 bps
Security	WPS/WEP/WPA/WPA2/WPA3
Flash	Default 4MByte, Support expansion

2.1. Static electricity requirement

Ai-M62-13 is an electrostatic sensitive device. Therefore, you need to take special precautions when carrying it.



Figure 2 ESD preventive measure

2.2. Electrical characteristics

Table 2 Electrical characteristics table

Parameters	Conditio	Min.	Typical value	Max.	Unit
Supply voltage	VDD	2.97	3.3	3.6	V
I/O	VIL	-	-	0.3*VDDIO	V
	VIH	-	0.7*VDDIO	-	V
	VOL	-	-	0.1*VDDIO	V
	VOH	-	-	0.9*VDDIO	V
	IMAX	-	-	-	15

2.3. Wi-Fi RF Performance

Table 3 Wi-Fi RF performance table

Description	Typical value			Unit
Frequency range	2400 ~ 2483.5MHz			MHz
Output Power				
Mode	Min.	Typical value	Max.	Unit
11ax mode HE40,PA output power	-	16	-	dBm
11ax mode HE20,PA output power	-	17	-	dBm
11n mode HT40,PA output power	-	19	-	dBm
11n mode HT20,PA output power	-	19	-	dBm
11g mode, PA output power	-	19	-	dBm
11b mode, PA output power	-	22	-	dBm
Output Power				
Mode	Min.	Typical value	Max.	Unit
11b, 1 Mbps	-	-98	-	dBm
11b, 11 Mbps	-	-90	-	dBm
11g, 6 Mbps	-	-93	-	dBm
11g, 54 Mbps	-	-76	-	dBm
11n, HT20 (MCS7)	-	-73	-	dBm
11ax, HE20 (MCS9)	-	-70	-	dBm
11ax, HE40 (MCS9)	-	-67	-	dBm

2.4. BLE RF Performance

Table 4 BLE RF performance table

Description	Typical value			Unit
Frequency range	2400 ~ 2483.5MHz			MHz
Output Power				
Rate Mode	Min.	Typical value	Max.	Unit
1Mbps	-	10	15	dBm
2Mbps	-	10	15	dBm
Receive Sensitivity				
Rate Mode	Min.	Typical value	Max.	Unit
1Mbps sensitivity@30.8%PER	-	-99	-	dBm
2Mbps sensitivity@30.8%PER	-	-97	-	dBm

2.5. Power

The following power consumption data are based on a 3.3V power supply, 25°C ambient temperature, and measured using an internal voltage regulator.

- All measurements are made at the antenna interface with a filter.
- All transmission data are based on 100% duty cycle in continuous transmission mode.

Table 5 Power consumption

Mode	Min.	AVG	Max.	Unit
Tx 802.11b, 11Mbps, POUT=+22dBm	-	415	-	mA
Tx 802.11g, 54Mbps, POUT =+19dBm	-	298	-	mA
Tx 802.11n, MCS7, POUT =+19dBm	-	300	-	mA
Tx 802.11ax, MCS9, POUT =+17dBm	-	280	-	mA
Rx 802.11b,packet length 1024 byte	-	59	-	mA
Rx 802.11g,packet length 1024 byte	-	59	-	mA
Rx 802.11n,Packet length 1024 byte	-	59	-	mA
Rx 802.11b,packet length 1024 byte	-	59	-	mA

3. Appearance Dimensions

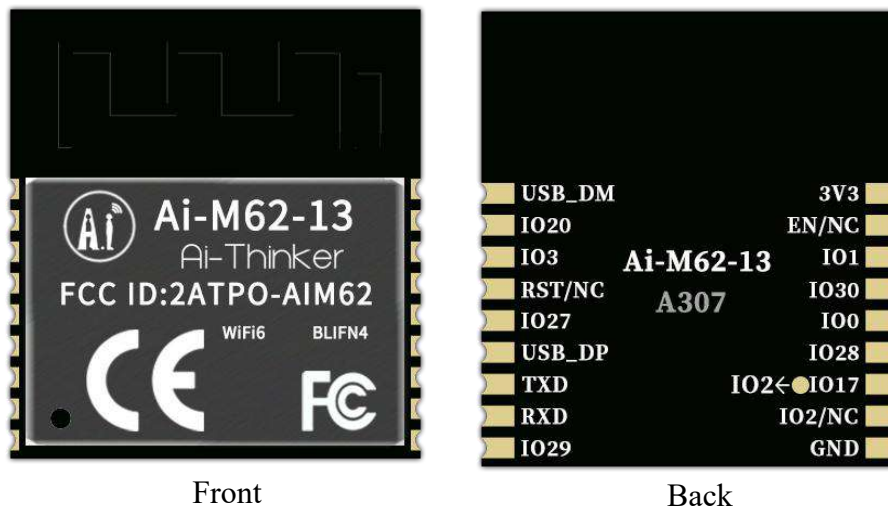

Figure 3 Appearance diagram (Rendering figure is for reference only,subject to physical objects)

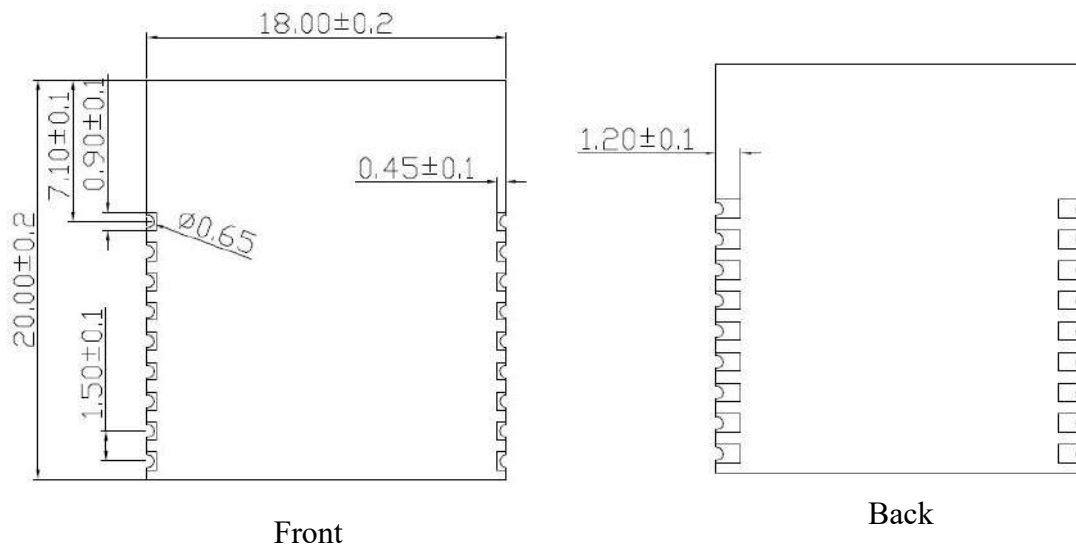

Figure 4 Dimension diagram

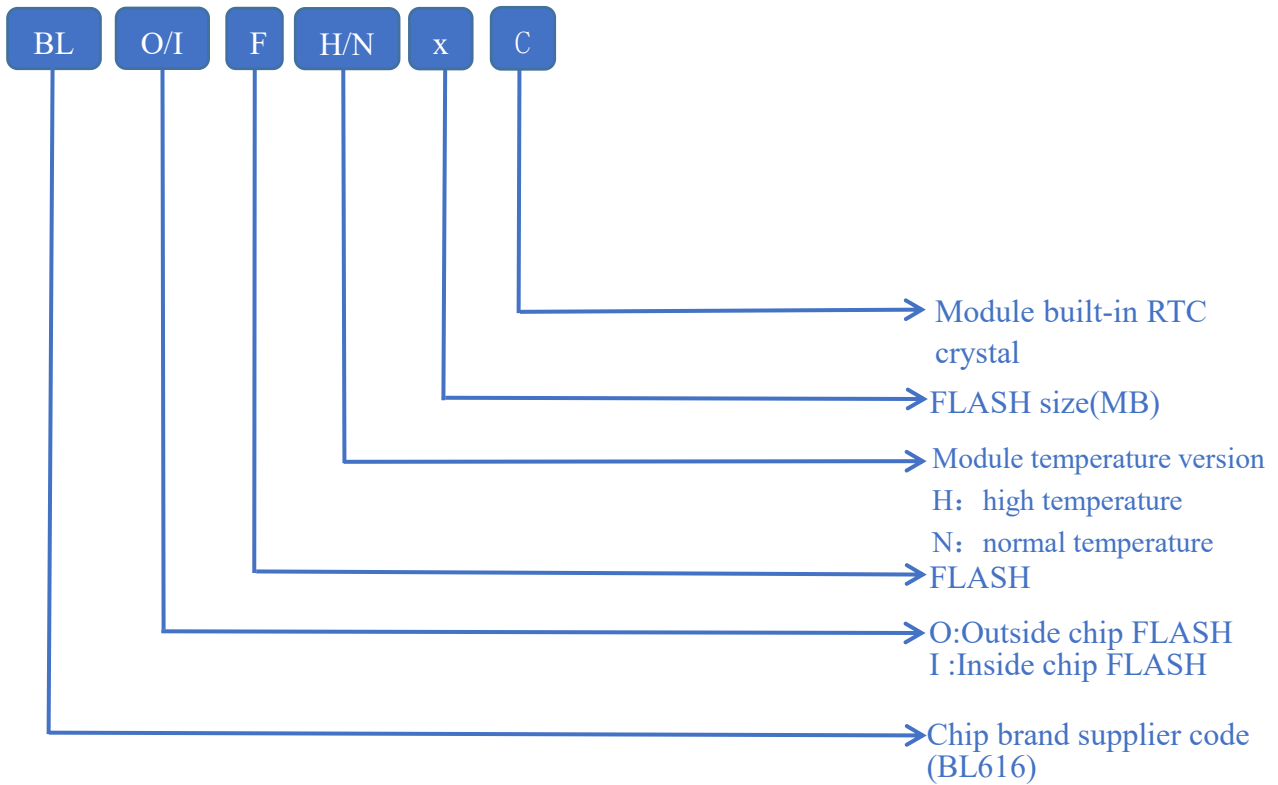

Figure 5 Shield printing information

4. Pin Definition

Ai-M62-13 module is connected with a total of 16 pins, as shown in the pin schematic diagram, pin function definition table is the interface definition.

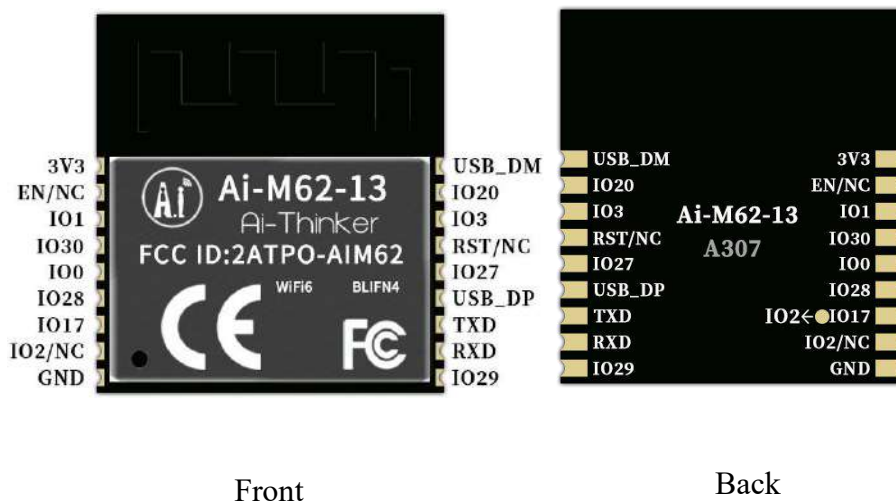

Figure 6 Schematic diagram of module pins

Table 6 Pin function definition table

No.	Name	Function
1	VCC	3.3V power supply; The output current of external power supply is recommended to be above 500mA.
2	EN/NC	The default is chip enabled, high level is valid, and RST cannot be used at the same time.
3	IO1	GPIO1/SPI_SCLK/I2S_FS/I2C_SDA/ADC_CH8/PWM0
4	IO30	GPIO30/SPI_MISO/I2S_DI/I2S_RCLK_O/I2C_SCL/PWM0
5	IO0	GPIO0/SPI_SS/I2S_BCLK/I2C_SCL/ADC_CH9/PWM0
6	IO28	GPIO28/SPI_SS/I2S_BCLK/I2C_SCL/ADC_CH11/PWM0
7	IO17	Available by default, the IO port is shared with the 32.768KHz crystal output PIN pin inside the module. If the module of the internal patch 32.768KHz crystal oscillator is customized, the IO is in NC state. GPIO17/SPI_SCLK/I2S_FS/I2C_SDA/XTAL_32K_OUT/PWM0
8	IO2/NC	The default NC is not available. If you need to use it, please contact Anxin. If elicited, support Bootstrap/GPIO2/SPI_MISO/I2S_DI/I2S_RCLK_O/I2C_SCL/ADC_CH2/PWM0
9	GND	Grounding
10	IO29	GPIO29/SPI_SCLK/I2S_FS/I2C_SDA/PWM0
11	RXD	RXD/GPIO22/SPI_MISO/I2S_DI/I2S_RCLK_O/I2C_SCL/PWM0
12	TXD	TXD/GPIO21/SPI_SCLK/I2S_FS/I2C_SDA/ADC_RCAL_VOUT/PWM0
13	USB_DP	USB_DP
14	IO27	GPIO27/SPI_MOSI/I2S_DO/I2S_RCLK_O/I2C_SDA/ADC_CH10/PWM0
15	RST/NC	The default is suspended, can be customized as reset pin, low level is valid, if you need to use it, please contact Anxin
16	IO3	GPIO3/SPI_MOSI/I2S_DO/I2S_RCLK_O/I2C_SDA/ADC_CH3/PWM0
17	IO20	GPIO20/SPI_SS/I2S_BCLK/I2C_SCL/ADC_CH0/PWM0
18	USB_DM	USB_DM

Note: 1. GPIO2 is used as a Bootstrap. When the power-on moment is high, the module enters the burning mode. When the power-on moment is low, the module starts normally.

5. Schematic

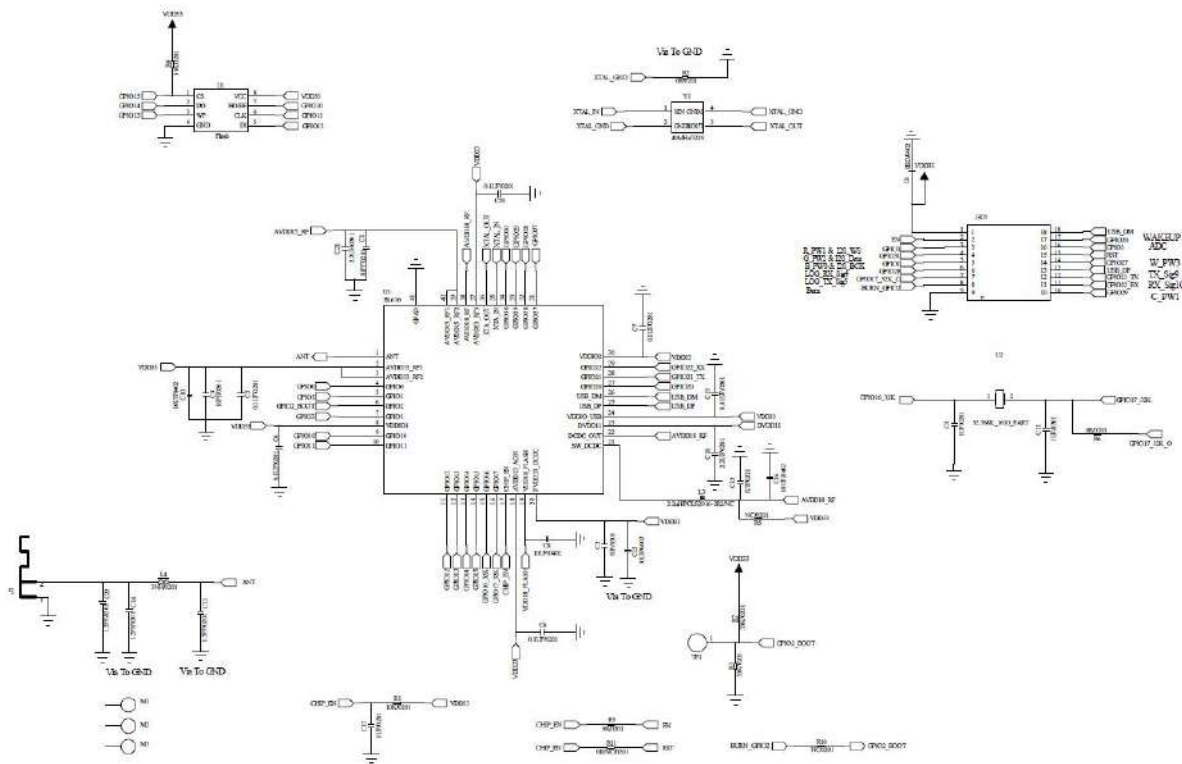

Figure 7 Module schematic

6. Antenna parameters

6.1. Schematic diagram of the antenna test prototype

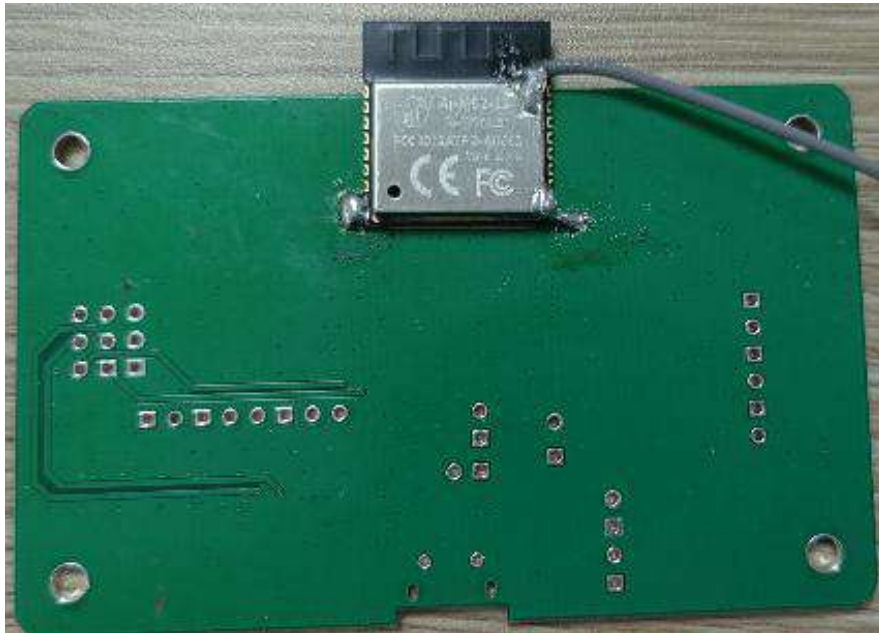

Figure 8 Schematic diagram of the antenna test prototype

6.2. Antenna S parameter

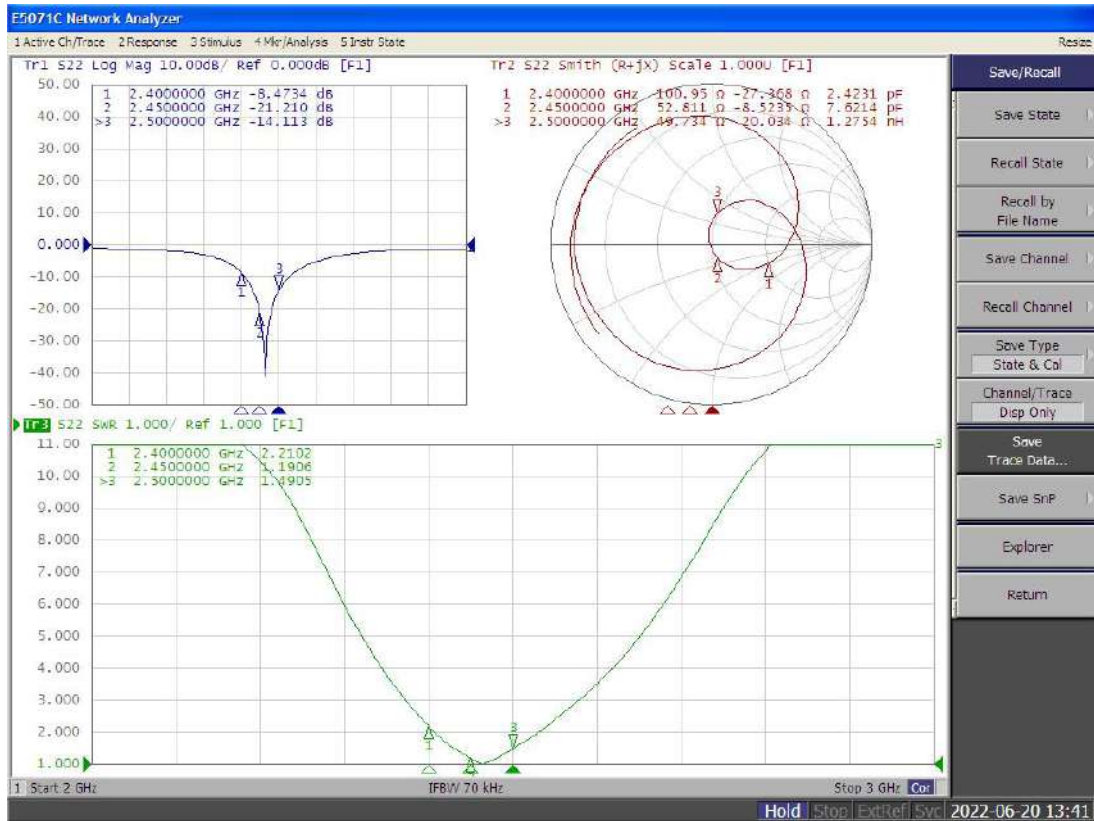

Figure 9 Antenna S parameters

6.3. Antenna Gain and Efficiency

Table 7 Antenna Gain and efficiency

Frequency ID	1	2	3	4	5	6	7	8	9	10	11
Frequency(MHz)	2400	2410	2420	2430	2440	2450	2460	2470	2480	2490	2500
Gain (dBi)	0.96	1.14	1.37	1.69	1.91	2.13	2.29	2.32	2.19	2.00	1.85
Efficiency (%)	47.66	49.80	52.36	56.63	60.58	63.67	64.71	64.31	62.38	60.55	58.85

6.4. Antenna pattern

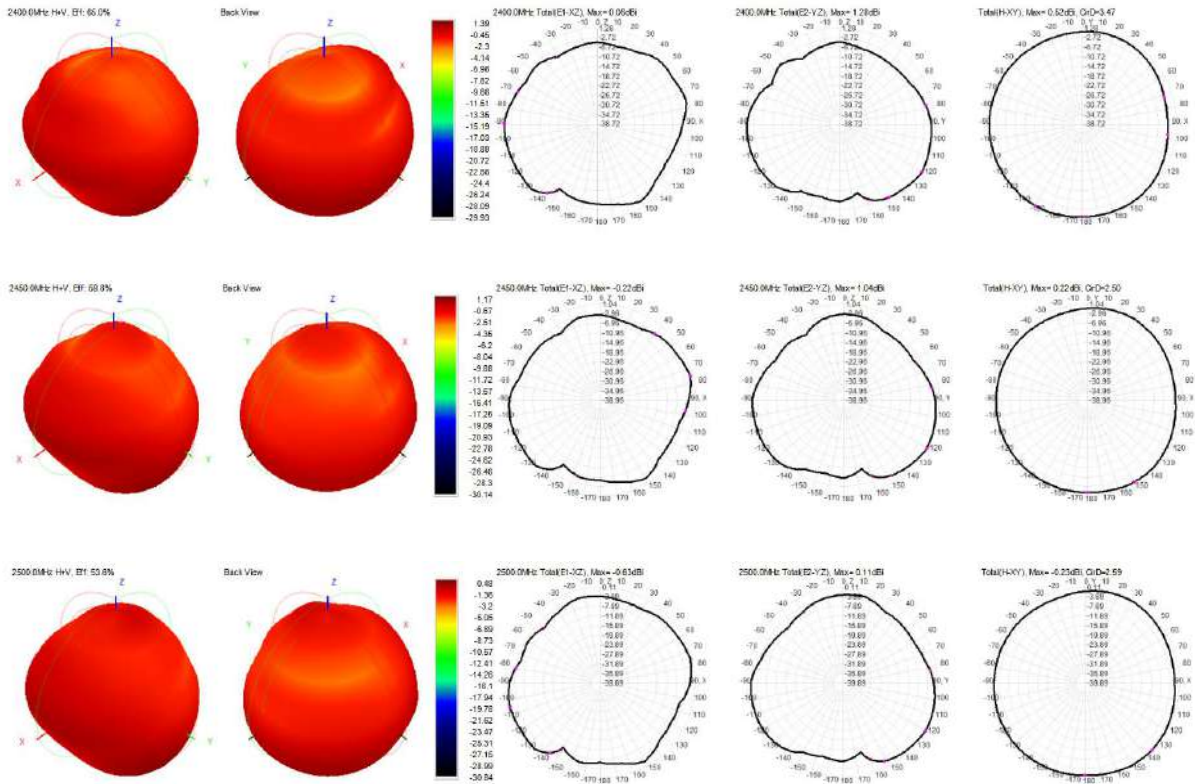

Figure 10 Antenna pattern

7. Design Guidance

7.1. Module application circuit

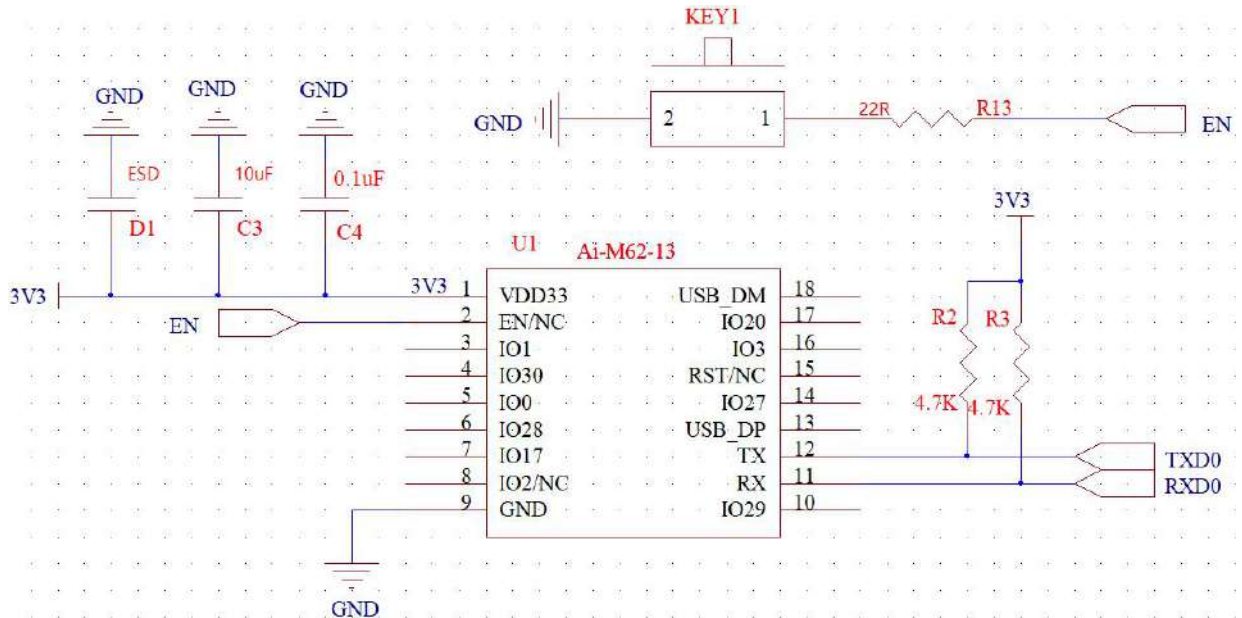

Figure 11 Application circuit diagram

- IO2 is the module start control pin, which is in normal working mode at low level and in firmware burning mode at high level. The default low level inside the chip.
- IO2/NC, not available by default
- IO17/NC, available by default. The IO port is shared with the 32.768KHz crystal output PIN pin inside the module. If the module of the internal patch 32.768KHz crystal oscillator is customized, the IO is in NC state.

7.2. Recommend PCB footprint size

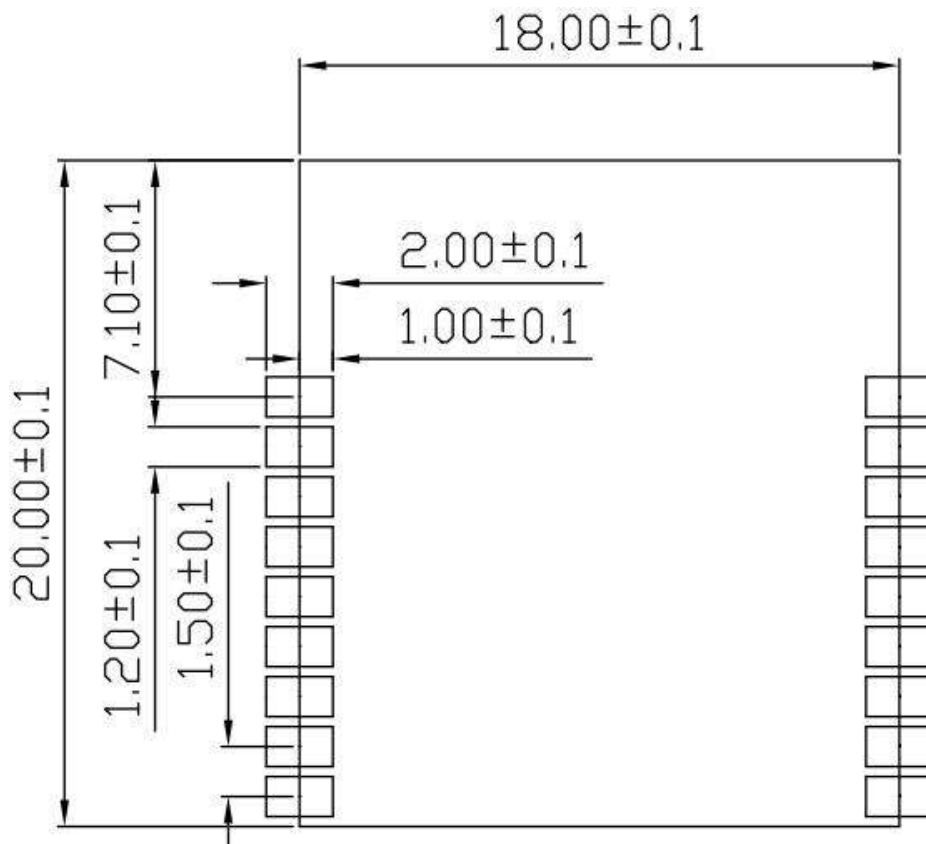

Figure 12 Recommend PCB footprint size

7.3. Antenna layout requirements

- The following two methods are recommended for the installation position on the mainboard:

Option 1: put the module on the edge of the motherboard, and the antenna area extends out of the edge of the motherboard.

- Option 2: put the module on the edge of the motherboard, the edge of the motherboard at the antenna position hollowed out an area.

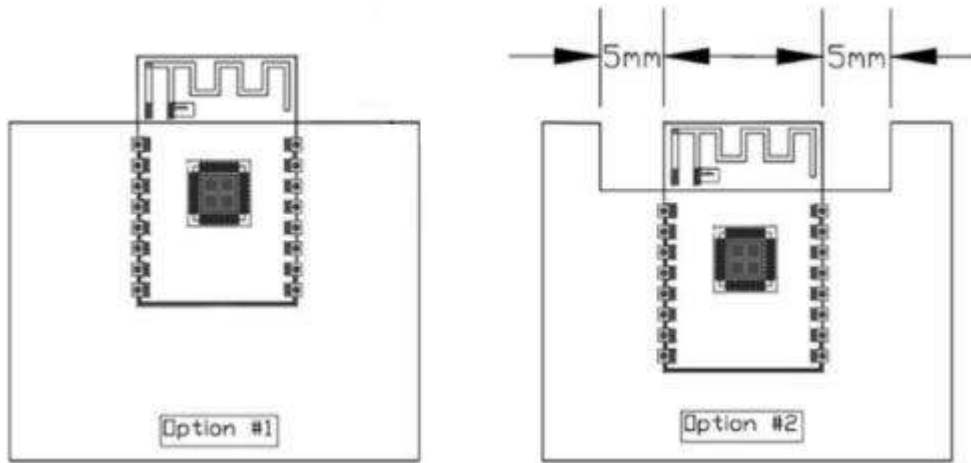

Figure 13 Antenna layout diagram

7.4. Power supply

- Recommended 3.3V voltage, peak current over 500mA.
- Power supply is recommend to use LDO; if the DC-DC is used, the ripple is recommended to be controlled within 30mV
- DC-DC power supply circuit proposes to reserve the dynamic response capacitance to optimize the output ripple with large load changes.
- It is recommended to add ESD devices to the 3.3V power interface.

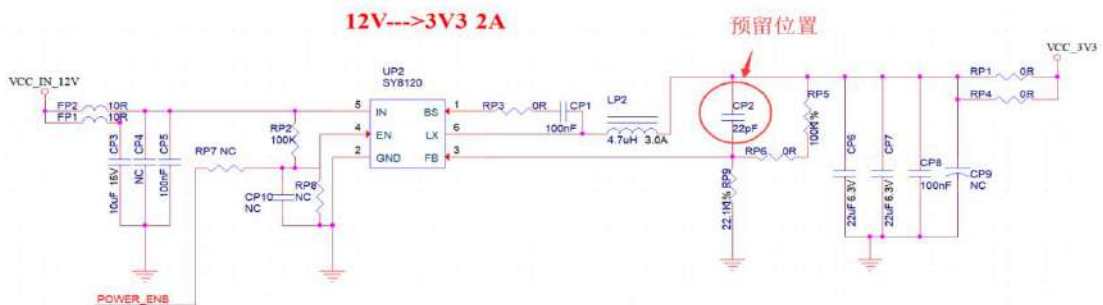

Figure 14 DC-DC step-down circuit diagram

7.5. GPIO

- There are some IO ports on the periphery of the module. If you need to use it, it is recommended to connect a 10-100 ohm resistor in series with the IO port. This inhibits overshoot and makes both sides level more stable. It is helpful for EMI and ESD.
- For special I/O ports to be pulled up and down, refer to the usage instructions in the specifications, which may affect the module startup configuration.
- The IO port of the module is 3.3V. If the IO level of the main control and the module do not match, a level conversion circuit needs to be added.
- If the I/O port is directly connected to a peripheral port or terminals, for example, a pin row, reserve an ESD device near the terminal of the I/O cable.

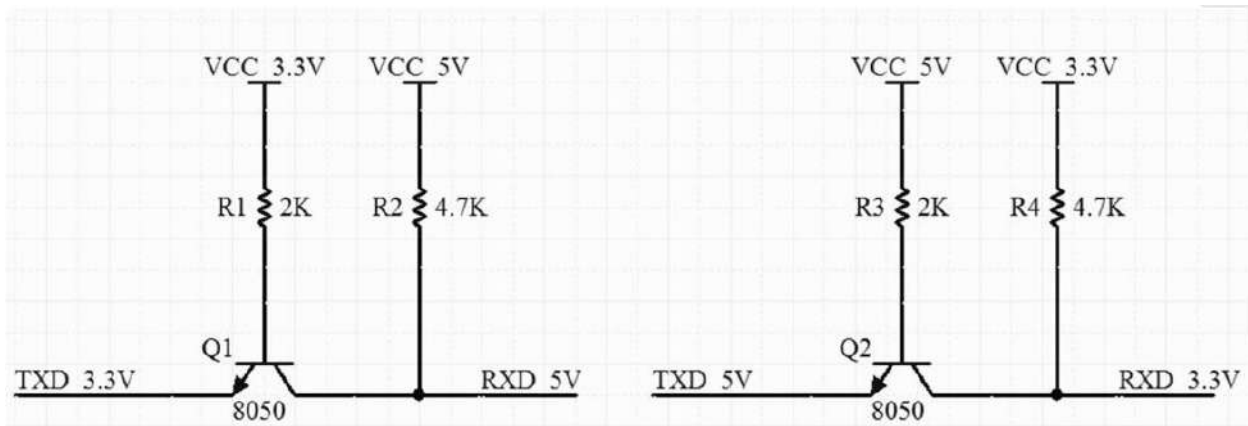

Figure 15 Level convert circuit

8. Storage conditions

Products sealed in moisture-proof bags should be stored in a non-condensing atmosphere of <math><40\text{ }^\circ\text{C}/90\%\text{RH}</math>.

The module has a moisture sensitivity rating of MSL 3.

After the vacuum bag is opened, it must be used within 168 hours at $25\pm 5^\circ\text{C}/60\%\text{RH}$, otherwise it needs to be baked before it can be put on line again.

9. Reflow welding curve diagram

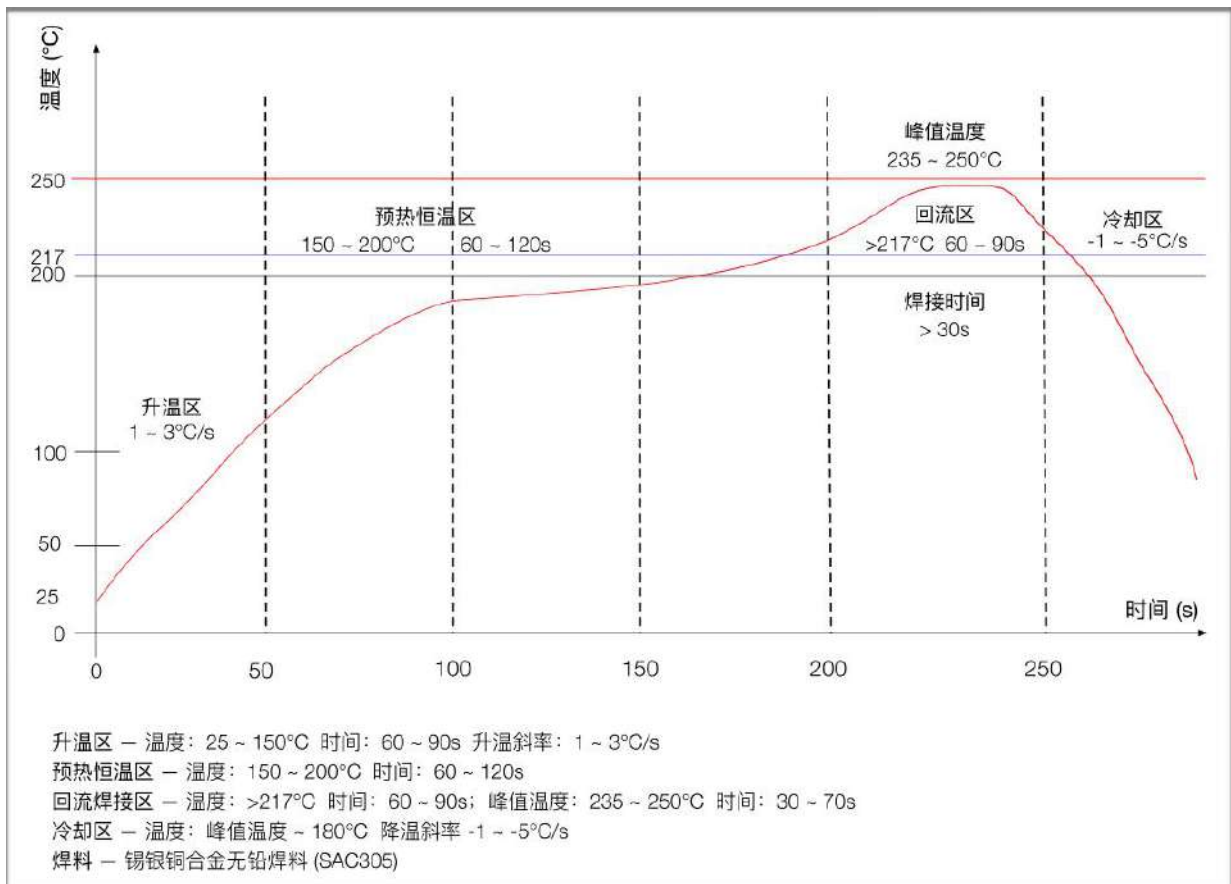

Figure 16 Reflow welding diagram

10. Product Packaging Information

Ai-M62-13 module was packaged in a tape, 650 pcs/reel. As shown in the below image:



Figure 17 Package and packing diagram

11. Contact us

[Ai-Thinker official website](#)

[Office forum](#)

[Develop DOCS](#)

[LinkedIn](#)

[Tmall shop](#)

[Taobao shop](#)

[Alibaba shop](#)

[Technical support email: support@aithinker.com](mailto:support@aithinker.com)

[Domestic business cooperation: sales@aithinker.com](mailto:sales@aithinker.com)

[Overseas business cooperation: overseas@aithinker.com](mailto:overseas@aithinker.com)

Company Address: Room 403,408-410, Block C, Huafeng Smart Innovation Port, Gushu 2nd Road, Xixiang, Baoan District, Shenzhen.

Tel: +86-0755-29162996



WeChat mini program



WeChat official account

Disclaimer and copyright notice

The information in this article, including the URL address for reference, is subject to change without notice.

The document is provided "as is" without any guarantee responsibility, including any guarantee for merchantability, suitability for a specific purpose, or non-infringement, and any guarantee mentioned elsewhere in any proposal, specification or sample. This document does not bear any responsibility, including the responsibility for infringement of any patent rights arising from the use of the information in this document. This document does not grant any license for the use of intellectual property rights in estoppel or other ways, whether express or implied.

The test data obtained in the article are all obtained from Ai-Thinker's laboratory tests, and the actual results may vary slightly.

All brand names, trademarks and registered trademarks mentioned in this article are the property of their respective owners, and it is hereby declared.

The final interpretation right belongs to Shenzhen Ai-Thinker Technology Co., Ltd.

Notice

Due to product version upgrades or other reasons, the contents of this manual may be changed.

Shenzhen Ai-Thinker Technology Co., Ltd. reserves the right to modify the contents of this manual without any notice or prompt.

This manual is only used as a guide. Shenzhen Ai-Thinker Technology Co., Ltd. makes every effort to provide accurate information in this manual. However, Shenzhen Ai-Thinker Technology Co., Ltd. does not guarantee that the contents of the manual are completely free of errors. All statements and information in this manual And the suggestion does not constitute any express or implied guarantee.