



SPECIFICATION FOR APPROVAL

规 格 书

Add: Rm.2705, Modern International Building, Jintian Road, Futian District, Shenzhen, Guangdong Province, China

Phone: +86-755-23937707 Fax: +86-755-88351759 Website: www.rficy.com Email: info@rficy.com



GENERAL SPECIFICATIONS (电气特性) :

1. Holder type: (型号)	HC-49S	
2. Normal Frequency: (标称频率)	JMR6.7458M.	
3. Oscillation Mode: (振动模式)	AT-Fundamental	
4. Load Capacitance(CL): (负载电容)	20 PF	
5. Frequency Tolerance 25±3°C: (频率偏差 25±3°C)	± 30 PPM	
6. Effective Series Resistance: (等效电阻)	≤ 80Ω	
7. DLD2 (不同功率下之最大与最小阻抗差值)	≤ 18Ω	0.01 uW~100 uW 10 steps
8. RLD2 (不同功率下之最大阻抗值)	≤ 60Ω	0.01 uW~100 uW 10 steps
9. FDL D (不同功率下之最大与最小 FR 差值)	≤ 8 PPM	0.01 uW~100 uW 10 steps
10. Shunt Capacitance(C0): (静态电容)	≤ 7 PF	
11. Typical drive level: (激励功率)	100 uW TYP.	
12. Operation Temperature Range: (工作温度范围)	-20°C to +70°C	
13. Stability Over Temperature Range: (工作温度频率偏差)	±20 PPM at -20°C to+70°C	
14. Insulation Resistance: (绝缘阻抗)	≥500 MΩ at DC 100V	
15. Aging: (老化率)	±5 PPM/Year	
16. Storage Temperature: (存储温度)	-50°C to +105°C	
17. Test circuit (测试仪器)	S&A 250B Pi-Network Crystal Measurement System	
Remark (备注) :		

Add: Rm.2705, Modern International Building, Jintian Road, Futian District, Shenzhen, Guangdong Province, China

Phone: +86-755-23937707 Fax: +86-755-88351759 Website: www.rficy.com Email: info@rficy.com



DIMENSIONS SPECIFICATIONS (外形尺寸)

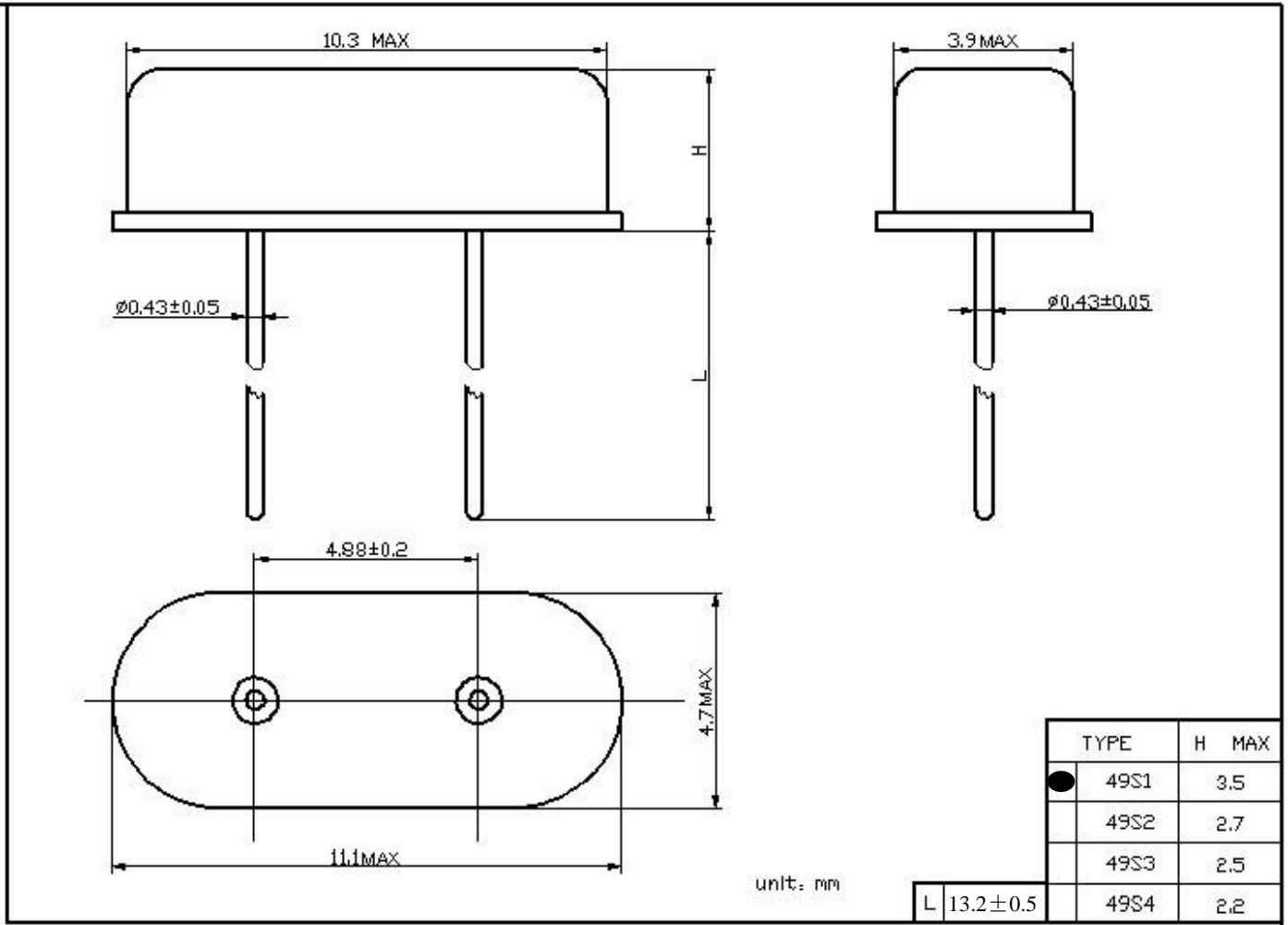

MARK (印字)

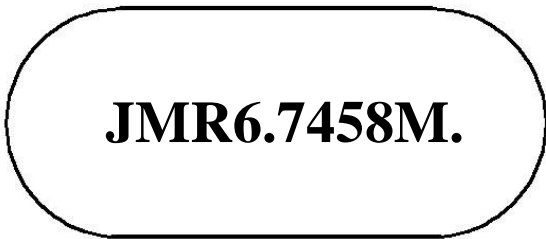

Add: Rm.2705, Modern International Building, Jintian Road, Futian District, Shenzhen, Guangdong Province, China

Phone: +86-755-23937707 Fax: +86-755-88351759 Website: www.rficy.com Email: info@rficy.com



Report of bills of materials and suppliers (物料清单及供应商)

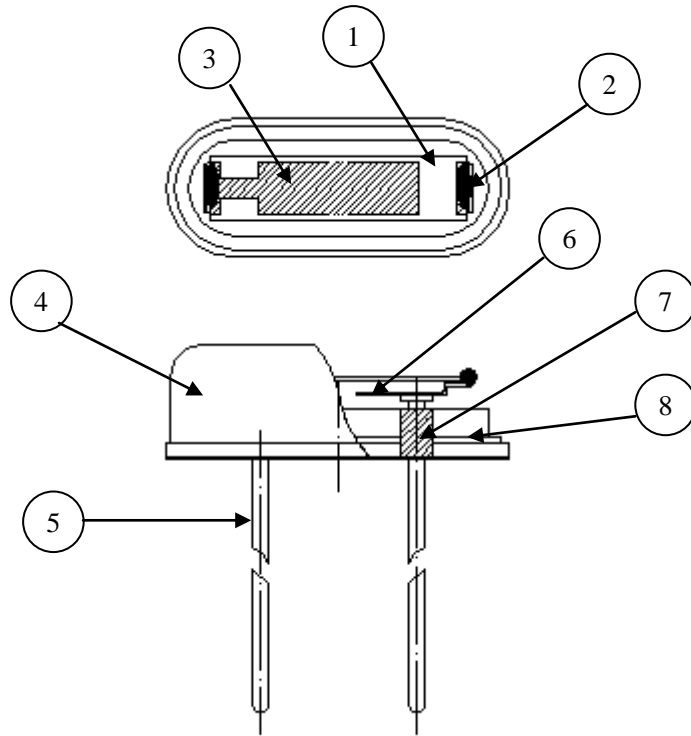

NO.	Product name 部件名称	MATERIALS 材质	QTY 数量	Supplier 供应商
1	Blank 晶片	SIO2	1	LingHaiRiTai 临海日泰
2	Silver paste 导电胶	3301F	2	THREE BOND 三键
3	Silver 电极	Ag	2	GuangYang 光洋
4	Cover 外壳	Au	1	TongLingJingSai 铜陵晶赛
5	Lead 引线	Kovar	2	RiZhaoRongDa 日照荣达
6	Pin 簧片	C7701	2	RiZhaoRongDa 日照荣达
7	GLASS 玻璃珠	GLASS	2	RiZhaoRongDa 日照荣达
8	Base 底板	SPCC-SD	1	RiZhaoRongDa 日照荣达

Add: Rm.2705, Modern International Building, Jintian Road, Futian District, Shenzhen, Guangdong Province, China

Phone: +86-755-23937707 Fax: +86-755-88351759 Website: www.rficy.com Email: info@rficy.com



PACKING METHOD(包装样式)

- 1、Packed 200 pcs in 1 vinyl bag
200pcs一小袋
- 2、Packed 10 vinyl bag in 1 box, Size of carton:150mm*100mm*100mm
10小袋一盒，纸盒尺寸：150mm*100mm*100mm
- 3、Packed 10 box in 1 carton
10盒一箱
- 4、There are 20000 pcs in 1 carton
总计20000pcs 一箱
- 5、Size of carton:320mm*270mm*230mm
外箱尺寸：320mm*270mm*230mm
- 6、Label mode
标签样式
A: Part NO.
B: Holder Type
C: Frequency
D: CL
E: $\Delta f1/f0$
F: ESR
G: Quantity

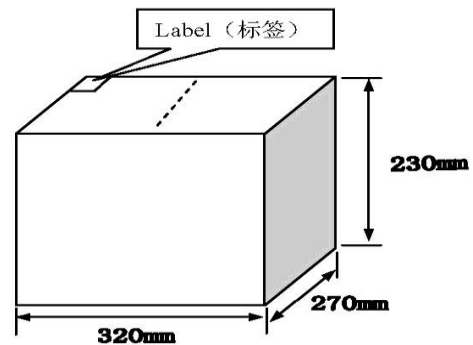
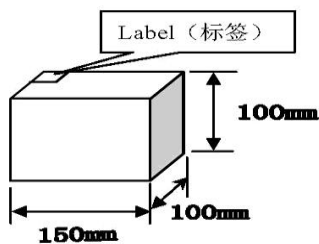

Add: Rm.2705, Modern International Building, Jintian Road, Futian District, Shenzhen, Guangdong Province, China

Phone: +86-755-23937707 Fax: +86-755-88351759 Website: www.rficy.com Email: info@rficy.com



RELIABILITY SPECIFICATIONS 可靠性测试标准

NO.	ITEMS 项目	CONDITIONS 条件	SPECIFICATIO N 规格		
1	Lead Bend 端子强度	a) Pulling: According to experiment of IEC 68-2-21 Ua1 experiment, pull 10N. a) 拉力: 按IEC 68-2-21中试验Ua1进行, 拉力10N。	B		
		b) Bending: According to experiment of IEC 68-2-21 method Ub. Add the burthen of 5N to lead, and 2.5±0.5mm refer to the base for 3 times . b) 弯曲强度: 按IEC 68-2-21中试验Ub进行, 负荷应限制在距晶体元件本体2.5±0.5mm处开始弯曲, 所加质量负荷为5N, 弯曲次数为3次。			
2	Solderability 可焊性	According to experiment of IEC 68-2-20 Ta method 1, Solder temperature is 235℃. 按IEC 68-2-20中试验Ta的方法1进行, 焊接温度235℃。	C		
3	Solder heat resistance 耐焊接热	According to experiment of IEC 68-2-20 method Tb 1A: solder slit method. Solder temperature: 260±5℃, dip time 10±1s. 按IEC 68-2-20试验Tb方法1A: 焊锡槽方法进行。 焊接温度: 260±5℃, 浸入时间: 10±1秒。	A		
4	Vibration 耐振性	According to experiment of 68-2-6 method Fc, The entire frequency range, from 10Hz to 55Hz and return to 10Hz, and shall be transferred in 1 min. Amplitude (total excursion): 1.5mm Duration=2 hours for each of the main axes (x,y,z). 按IEC 68-2-6试验Fc进行, 振动频率在1分钟内从10~55Hz, 再回到10Hz, 振幅1.5mm, X、Y、Z三个方向各2小时。	A		
5	Shock 耐冲击性	According to experiment of IEC 68-2-27 method Ea, the biggest acceleration : 981m/s ² (100g), work time : 6ms, and 6 surfaces, and 3 directions for each surface, and shall be Shocked 18 times in total. 按IEC 68-2-27试验Ea进行, 最大加速度: 981m/s ² (100g), 作用时间: 6ms, 6面, 每面三个方向, 共18次。	AB		
6	Cold 耐寒性	According to experiment of IEC 68-2-1 method Aa, The quartz crystal unit should be stored at a temperature -40±3℃ for 2 hours, and then it shall be subjected to standard atmospheric conditions for 1 hour, after which measurement shall be made. 按IEC 68-2-1试验Aa进行, 晶体在温度-40±3℃中放置2小时后, 在常温常湿状态下放置1小时后测试。	A		
7	Dry Heat 干热	According to experiment of IEC 68-2-2 Ba, quartz crystal unit should be stored at a temperature 85±2℃ for 2 hours. Then it shall be subjected to standard atmospheric conditions for 1 hour, after which measurement shall be made. 按IEC 68-2-2试验Ba进行, 晶体在温度85±2℃中放置2小时后, 在常温常湿状态下放置1小时后测试。	A		
8	High heat and high humidity 稳 态湿热	According to experiment of IEC 68-2-3 method Ta, quartz crystal unit should be stored at a temperature 40±2℃ and at humidity 90~95% for 96 hours. Then it shall be subjected to standard atmospheric conditions for 1 hour. 按IEC 68-2-3试验Ta进行, 晶体在温度40±2℃, 湿度90~95%中放置96小时后, 在常温常湿状态下放置1小时后测试。	A		
9	Temperature Cycling 温度 变化	According to experiment of IEC 68-2-14 method Na, quartz crystal unit shall be made 5 temperature cycles, and then it shall be subjected to standard atmospheric conditions for 1 hour. 按IEC 68-2-14试验Na进行, 晶体按下表做5个温度循环后, 在常温常湿状态下放置1小时后测试。	A		
		TEMPERATURE 温度		STORE TIME 放置时间	
		1		-40±3℃	30min
		2		Normal Temp(常温)	30sec
3	100±2℃	30min			
4	Normal Temp(常温)	30sec			

Add: Rm.2705, Modern International Building, Jintian Road, Futian District, Shenzhen, Guangdong Province, China

Phone: +86-755-23937707 Fax: +86-755-88351759 Website: www.rficy.com Email: info@rficy.com

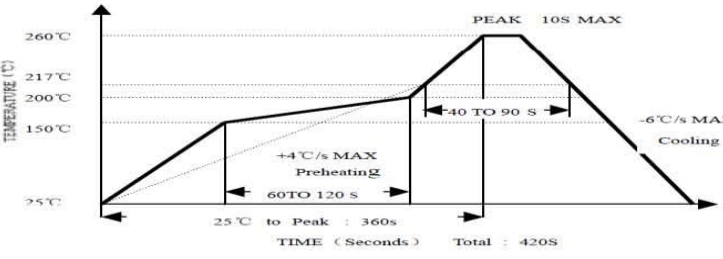

10	Drop 跌落	According to experiment of IEC 68-2-32 method Ed,quartz crystal unit shall be dropped from 75cm height on 3cm hard board for 3 times. 按IEC 68-2-32试验Ed进行, 晶体从75厘米高度自由下落至3厘米硬木板, 重复3次。	AB
11	Reflow 回流焊	Reflow soldering cure see the chart. 回流焊曲线见下图。 	A
12	Leakage 气密性	Alcohol press method:quartz crystal unit shall be immersed in the can,and pressed by0.5kg press for 30min;Then put away press ,and dry it.Quartz crystal unit shall be test insulation resistance by 100V volts d.c for 1 min. 酒精加压法: 晶体浸入酒精罐中, 加压(压力0.5kg, 时间30分钟); 撤去压力后, 晾干晶体, 测量引线与外壳之间绝缘电阻(100V直流电压, 时间1分钟)。	D
13	Aging 老化	Quartz crystal unit shall be stored at a temperature 85±2°C for 720±12 hours(30days),and then it shall be subjected to standard atmospheric conditions for 1 hour. 晶体在温度85±2°C中放置720小时(30天)±12小时后, 在常温常湿状态下放置1小时后测试。	A

Accept Level:
判定标准:

No.	specification 标准
A	Satisfying the electric characteristic; Frequency change is at the range of 5PPM and resistance change is at the range of 5Ω. 电气性能可满足要求: 频率变化量在5ppm以内,电阻变化量在5Ω以内。
B	After each test,no visible damage shall be manifested,nor shall the hermetic seal break down 试验后, 无机械损伤
C	Dipping in 3 sec.A new uniform coating of solder shall covera minimum of 95% of the surface being immersed. 浸锡时间3秒以内, 引线挂锡面积95%以上。
D	Insulation resistance of leads shall be more than 500MΩ(100V DC). 端子之间的绝缘电阻≥500MΩ(100V DC)。

Add: Rm.2705, Modern International Building, Jintian Road, Futian District, Shenzhen, Guangdong Province, China

Phone: +86-755-23937707 Fax: +86-755-88351759 Website: www.rficy.com Email: info@rficy.com