



---

# HT32F65230/HT32F65240 Datasheet

**32-Bit Arm® Cortex®-M0+ BLDC Microcontroller,  
up to 64 KB Flash and 8 KB SRAM with 1 MSPS ADC,  
CMP, OPA, USART, UART, SPI, I<sup>2</sup>C, MCTM, GPTM,  
SCTM, BFTM, CRC, RTC, WDT, DIV and PDMA**

Revision: V1.30 Date: April 21, 2022

[www.holtek.com](http://www.holtek.com)

## Table of Contents

<b>1 General Description</b> .....	<b>6</b>
<b>2 Development Tools</b> .....	<b>7</b>
<b>3 Features</b> .....	<b>7</b>
Core .....	7
On-Chip Memory .....	7
Flash Memory Controller – FMC.....	8
Reset Control Unit – RSTCU .....	8
Clock Control Unit – CKCU.....	8
Power Management Control Unit – PWRCU .....	9
External Interrupt/Event Controller – EXTI .....	9
Analog to Digital Converter – ADC .....	9
Operational Amplifier – OPA .....	9
Comparator – CMP.....	10
I/O Ports – GPIO.....	10
Motor Control Timer – MCTM .....	10
General-Purpose Timer – GPTM .....	11
Single-Channel Timer – SCTM .....	11
Basic Function Timer – BFTM .....	12
Watchdog Timer – WDT.....	12
Real Time Clock – RTC .....	12
Inter-Integrated Circuit – I <sup>2</sup> C .....	12
Serial Peripheral Interface– SPI .....	13
Universal Asynchronous Receiver Transmitter – UART .....	13
Universal Synchronous Asynchronous Receiver Transmitter – USART .....	14
Cyclic Redundancy Check – CRC .....	14
Peripheral Direct Memory Access – PDMA .....	15
Hardware Divider – DIV .....	15
Debug Support.....	15
Package and Operation Temperature .....	15
<b>4 Overview</b> .....	<b>16</b>
Device Information.....	16
Block Diagram .....	17
Memory Map.....	18
Clock Structure .....	21

<b>5 Pin Assignment</b> .....	<b>22</b>
<b>6 Electrical Characteristics</b> .....	<b>26</b>
Absolute Maximum Ratings .....	26
Recommended DC Operating Conditions .....	26
On-Chip LDO Voltage Regulator Characteristics.....	26
Power Consumption .....	27
Reset and Supply Monitor Characteristics.....	28
External Clock Characteristics.....	29
Internal Clock Characteristics .....	30
System PLL Characteristics.....	31
Memory Characteristics .....	31
I/O Port Characteristics.....	32
ADC Characteristics .....	33
Comparator Characteristics .....	35
Operational Amplifier Characteristics.....	36
MCTM/GPTM/SCTM Characteristics.....	36
I <sup>2</sup> C Characteristics .....	36
SPI Characteristics .....	37
<b>7 Package Information</b> .....	<b>40</b>
48-pin LQFP (7mm×7mm) Outline Dimensions.....	41

## List of Tables

Table 1. Features and Peripheral List .....	16
Table 2. Register Map .....	19
Table 3. Pin Alternate Function .....	23
Table 4. Pin Description .....	24
Table 5. Absolute Maximum Ratings .....	26
Table 6. Recommended DC Operating Conditions .....	26
Table 7. LDO Characteristics .....	26
Table 8. Power Consumption Characteristics .....	27
Table 9. V <sub>DD</sub> Power Reset Characteristics .....	28
Table 10. LVD/BOD Characteristics .....	29
Table 11. High Speed External Clock (HSE) Characteristics .....	29
Table 12. Low Speed External Clock (LSE) Characteristics .....	30
Table 13. High Speed Internal Clock (HSI) Characteristics .....	30
Table 14. Low Speed Internal Clock (LSI) Characteristics .....	31
Table 15. System PLL Characteristics .....	31
Table 16. Flash Memory Characteristics .....	31
Table 17. I/O Port Characteristics .....	32
Table 18. ADC Characteristics .....	33
Table 19. Comparator Characteristics .....	35
Table 20. Operational Amplifier Characteristics .....	36
Table 21. MCTM/GPTM/SCTM Characteristics .....	36
Table 22. I <sup>2</sup> C Characteristics .....	36
Table 23. SPI Characteristics .....	37

## List of Figures

Figure 1. Block Diagram .....	17
Figure 2. Memory Map.....	18
Figure 3. Clock Structure .....	21
Figure 4. 48-pin LQFP Pin Assignment.....	22
Figure 5. ADC Sampling Network Model .....	34
Figure 6. I <sup>2</sup> C Timing Diagram.....	37
Figure 7. SPI Timing Diagram – SPI Master Mode .....	38
Figure 8. SPI Timing Diagram – SPI Slave Mode with CPHA = 1.....	39

# 1 General Description

The Holtek HT32F65230/HT32F65240 devices are high performance, low power consumption 32-bit microcontrollers based around an Arm® Cortex®-M0+ processor core. The Cortex®-M0+ is a next-generation processor core which is tightly coupled with Nested Vectored Interrupt Controller (NVIC), SysTick timer and including advanced debug support.

The device operates at a frequency of up to 60 MHz with a Flash accelerator to obtain maximum efficiency. It provides 64 KB of embedded Flash memory for code/data storage and 8 KB of embedded SRAM memory for system operation and application program usage. A variety of peripherals, such as Hardware Divider DIV, ADC, OPA, CMP, I<sup>2</sup>C, USART, UART, SPI, MCTM, GPTM, SCTM, BFTM, CRC-16/32, RTC, WDT, PDMA, SW-DP (Serial Wire Debug Port), etc., are also implemented in the device. Several power saving modes provide the flexibility for maximum optimization between wakeup latency and power consumption, an especially important consideration in low power applications.

The above features ensure that the device is suitable for use in a wide range of applications, especially in areas such as electric scooters, kitchen ventilators, ceiling fans, dust-free room fan filter units, other various fans and so on.

**arm** CORTEX

## 2 Development Tools

For rapid product development and to simplify device parameter setting, Holtek has provided relevant development tools which users can download from the following link:

<https://www.holtek.com/ht32f-series-blcd-motor-workshop>

## 3 Features

### Core

- 32-bit Arm® Cortex®-M0+ processor core
- Up to 60 MHz operating frequency
- Single-cycle multiplication
- Integrated Nested Vectored Interrupt Controller (NVIC)
- 24-bit SysTick timer

The Cortex®-M0+ processor is a very low gate count, highly energy efficient processor that is intended for microcontroller and deeply embedded applications that require an area optimized, low-power processor. The processor is based on the ARMv6-M architecture and supports Thumb® instruction sets, single-cycle I/O ports, hardware multiplier and low latency interrupt respond time.

### On-Chip Memory

- 64 KB on-chip Flash memory for instruction/data and options storage
- 8 KB on-chip SRAM
- Supports multiple booting modes

The Arm® Cortex®-M0+ processor access and debug access share the single external interface to external AHB peripherals. The processor access takes priority over debug access. The maximum address range of the Cortex®-M0+ is 4 GB since it has a 32-bit bus address width. Additionally, a pre-defined memory map is provided by the Cortex®-M0+ processor to reduce the software complexity of repeated implementation by different device vendors. However, some regions are used by the Arm® Cortex®-M0+ system peripherals. Refer to the Arm® Cortex®-M0+ Technical Reference Manual for more information. Figure 2 in the Overview chapter shows the memory map of the device, including code, SRAM, peripheral and other pre-defined regions.

## Flash Memory Controller – FMC

- Flash accelerator to obtain maximum efficiency
- 32-bit word programming with In System Programming Interface (ISP) and In Application Programming (IAP)
- Flash protection capability to prevent illegal access

The Flash Memory Controller, FMC, provides all the necessary functions, pre-fetch buffer and branch cache for the embedded on-chip Flash Memory. Since the access speed of the Flash Memory is slower than the CPU, a wide access interface with a pre-fetch buffer is provided for the Flash Memory in order to reduce the CPU waiting time which will cause CPU instruction execution delays. Flash Memory word programming / page erase functions are also provided.

## Reset Control Unit – RSTCU

- Supply supervisor:
  - Power On Reset / Power Down Reset – POR / PDR
  - Brown-Out Detector – BOD
  - Programmable Low Voltage Detector – LVD

The Reset Control Unit, RSTCU, has three kinds of reset, a power on reset, a system reset and an APB unit reset. The power on reset, known as a cold reset, resets the full system during power up. A system reset resets the processor core and peripheral IP components with the exception of the SW-DP controller. The resets can be triggered by external signals, internal events and the reset generators.

## Clock Control Unit – CKCU

- External 4 to 16 MHz crystal oscillator
- External 32.768 kHz crystal oscillator
- Internal 8 MHz RC oscillator trimmed to  $\pm 2$  % accuracy at 5.0 V operating voltage and 25 °C operating temperature
- Internal 32 kHz RC oscillator
- Integrated system clock PLL
- Independent clock divider and gating bits for peripheral clock sources

The Clock Control Unit, CKCU, provides a range of oscillator and clock functions. These include High Speed Internal RC oscillator (HSI), High Speed External crystal oscillator (HSE), Low Speed Internal RC oscillator (LSI), Low Speed External crystal oscillator (LSE), Phase Lock Loop (PLL), HSE clock monitor, clock prescaler, clock multiplexer, APB clock divider and gating circuitry. The clocks of AHB, APB and Cortex®-M0+ are derived from system clock (CK\_SYS) which can come from HSI, HSE, LSI, LSE or system PLL. Watchdog Timer (WDT) and Real Time Clock (RTC) use either the LSI or LSE as their clock source.



## Power Management Control Unit – PWRCU

- Single  $V_{DD}$  power supply: 2.5 V to 5.5 V
- Integrated 1.5 V LDO regulator for MCU core, peripherals and memories power supply
- Two power domains:  $V_{DD}$  and  $V_{CORE}$  power domains
- Two power saving modes: Sleep and Deep-Sleep modes

Power consumption can be regarded as one of the most important issues for many embedded system applications. Accordingly the Power Control Unit, PWRCU, in the device provides two types of power saving modes which are the Sleep and Deep-Sleep modes. These operating modes reduce the power consumption and allow the application to achieve the best trade-off between the conflicting demands of CPU operating time, speed and power consumption.

## External Interrupt/Event Controller – EXTI

- Up to 16 EXTI lines with configurable trigger source and type
- All GPIO pins can be selected as EXTI trigger source
- Source trigger type includes high level, low level, negative edge, positive edge or both edges
- Individual interrupt enable, wakeup enable and status bits for each EXTI line
- Software interrupt trigger mode for each EXTI line
- Integrated deglitch filter for short pulse blocking

The External Interrupt/Event Controller, EXTI, comprises 16 edge detectors which can generate a wake-up event or interrupt requests independently. Each EXTI line can also be masked independently.

## Analog to Digital Converter – ADC

- 12-bit SAR ADC engine
- Up to 1 Msps conversion rate
- Up to 8 external analog input channels for each ADC

Two 12-bit multi-channel Analog to Digital Converter are integrated in the device. There are multiplexed channels, which include 8 external channels on which the external analog signal can be supplied and 4 internal channels. If the input voltage is required to remain within a specific threshold window, the Analog Watchdog function will monitor and detect the signal. An interrupt will then be generated to inform the device that the input voltage is higher or lower than the set thresholds. There are three conversion modes to convert an analog signal to digital data. The A/D conversion can be operated in one shot, continuous and discontinuous conversion mode.

## Operational Amplifier – OPA

- Rail-to-rail operational amplifier
- Fixed dedicated I/O pins
- Internal output paths to A/D converter or comparator

Two Operational Amplifiers (OPA0~OPA1) are implemented within the device.

## Comparator – CMP

- Three Rail-to-rail comparators
- Each comparator has configurable negative inputs used for flexible voltage selection
  - Dedicated I/O pin
  - Internal voltage reference provided by 6-bit scaler
- Programmable hysteresis
- Programmable response speed and consumption
- Comparator output can be output to I/O or to multiple timer or ADC trigger inputs
- 6-bit scaler can be configurable to dedicated I/O for voltage reference
- Comparator n inverting input can be from CMP0N, CMPnN or CVREF
- Interrupt generation capability with wakeup from Sleep or Deep Sleep mode through the EXTI controller

Three general purpose comparators (CMP) are implemented within the device. They can be configured either as standalone comparators or combined with the different kinds of peripheral IP. Each comparator is capable of asserting interrupts to the NVIC or waking up the MCU from the Sleep or Deep Sleep mode through EXTI wakeup event management unit.

## I/O Ports – GPIO

- Up to 40 GPIOs
- Port A, B, C are mapped as 16 external interrupts – EXTI
- Almost all I/O pins have configurable output driving current

There are up to 40 General Purpose I/O pins, GPIO, named PA0 ~ PA15, PB0 ~ PB15 and PC0 ~ PC7 for the implementation of logic input/output functions. Each of the GPIO ports has a series of related control and configuration registers to maximize flexibility and to meet the requirements of a wide range of applications.

The GPIO ports are pin-shared with other alternative functions to obtain maximum functional flexibility on the package pins. The GPIO pins can be used as alternative functional pins by configuring the corresponding registers regardless of the input or output pins. The external interrupts on the GPIO pins of the device have related control and configuration registers in the External Interrupt Control Unit, EXTI.

## Motor Control Timer – MCTM

- 16-bit up, down, up/down auto-reload counter
- 16-bit programmable prescaler that allows division of the prescaler clock source by any factor between 1 and 65536 to generate the counter clock frequency
- Input Capture function
- Compare Match Output
- PWM waveform generation with Edge-aligned and Center-aligned Counting Modes
- Single Pulse Mode Output
- Complementary Outputs with programmable dead-time insertion
- Break input signals to assert the timer output signals in reset state or in a known state

The Motor Control Timer Module, MCTM, consists of one 16-bit up/down-counter, four 16-bit Capture/Compare Registers (CCRs), one 16-bit Counter-Reload Register (CRR), one 8-bit repetition counter and several control/status registers. It can be used for a variety of purposes which include input signal pulse width measurement, output waveform generation for signals such as compare match outputs, PWM outputs or complementary PWM outputs with dead-time insertion. The MCTM is capable of offering full functional support for motor control, hall sensor interfacing and break input.

## General-Purpose Timer – GPTM

- 16-bit up, down, up/down auto-reload counter
- Up to 4 independent channels for each timer
- 16-bit programmable prescaler that allows division of the prescaler clock source by any factor between 1 and 65536 to generate the counter clock frequency
- Input Capture function
- Compare Match Output
- PWM waveform generation with Edge-aligned and Center-aligned
- Single Pulse Mode Output
- Encoder interface controller with two inputs using quadrature decoder and Pulse/Direction Mode
- Master/Slave mode controller

The General-Purpose Timer Module, GPTM consists of one 16-bit up/down-counter, four 16-bit Capture/Compare Registers (CCRs), one 16-bit Counter-Reload Register (CRR) and several control / status registers. It can be used for a variety of purposes including general time measurement, input signal pulse width measurement, output waveform generation such as single pulse generation or PWM output generation. The GPTM also supports an Encoder Interface using a quadrature decoder with two inputs.

## Single-Channel Timer – SCTM

- 16-bit auto-reload up-counter
- One channel for each timer
- 16-bit programmable prescaler that allows division of the prescaler clock source by any factor between 1 and 65536 to generate the counter clock frequency
- Input Capture function
- Compare Match Output
- PWM waveform generation with Edge-aligned

The Single-Channel Timer Module, SCTM, consists of one 16-bit up-counter, one 16-bit Capture / Compare Register (CCR), one 16-bit Counter-Reload Register (CRR) and several control / status registers. It can be used for a variety of purposes including general timer, input signal pulse width measurement or output waveform generation such as PWM outputs.

## Basic Function Timer – BFTM

- 32-bit compare match up-counter – no I/O control
- One shot mode – counter stops counting when compare match occurs
- Repetitive mode – counter restarts when compare match occurs

The Basic Function Timer Module, BFTM, is a simple 32-bit up-counting counter designed to measure time intervals, generate one shots or generate repetitive interrupts. The BFTM can operate in two modes, repetitive and one shot modes. In the repetitive mode, the counter will restart at each compare match event. The BFTM also supports a one shot mode which will force the counter to stop counting when a compare match event occurs.

## Watchdog Timer – WDT

- 12-bit down-counter with 3-bit prescaler
- Provide reset to the system
- Programmable watchdog timer window function
- Register write protection function

The Watchdog Timer is a hardware timing circuitry that can be used to detect a system lock-up due to software trapped in a deadlock. It includes a 12-bit down-counter, a prescaler, a WDT delta value register, WDT operation control circuitry and a WDT protection mechanism. If the software does not reload the counter value before a Watchdog Timer underflow occurs, a reset will be generated when the counter underflows. In addition, a reset is also generated if the software reloads the counter before it reaches a delta value. It means that the counter reload must occur when the Watchdog timer value has a value within a limited window using a specific method. The Watchdog Timer counter can be stopped when the processor is in the debug mode. The register write protection function can be enabled to prevent an unexpected change in the Watchdog timer configuration.

## Real Time Clock – RTC

- 24-bit up-counter with a programmable prescaler
- Alarm function
- Interrupt and Wake-up control

The Real Time Clock, RTC, circuitry includes the APB interface, a 24-bit up-counter, a control register, a prescaler, a compare register and a status register. The RTC circuits are located in the V<sub>CORE</sub> power domain. When the device enters the power-saving mode, the RTC counter is used as a wakeup timer to let the system resume from the power saving mode.

## Inter-Integrated Circuit – I<sup>2</sup>C

- Supports both master and slave modes with a frequency of up to 1 MHz
- Provides an arbitration function and clock synchronization
- Supports 7-bit and 10-bit addressing modes and general call addressing
- Supports slave multi-addressing mode using address mask function

The I<sup>2</sup>C module is an internal circuit allowing communication with an external I<sup>2</sup>C interface which is an industry standard two-wire serial interface used for connection to external hardware. These two serial lines are known as a serial data line SDA, and a serial clock line SCL. The I<sup>2</sup>C module provides three data transfer rates: 100 kHz in the Standard mode, 400 kHz in the Fast mode and 1 MHz in the Fast plus mode. The SCL period generation registers are used to setup different kinds of duty cycle implementations for the SCL pulse.

The SDA line which is connected directly to the I<sup>2</sup>C bus is a bidirectional data line between the master and slave devices and is used for data transmission and reception. The I<sup>2</sup>C module also has an arbitration detection and clock synchronization function to prevent situations where more than one master attempts to transmit data to the I<sup>2</sup>C bus at the same time.

## Serial Peripheral Interface– SPI

- Supports both master and slave modes
- Frequency of up to ( $f_{PCLK}/2$ ) MHz for the master mode and ( $f_{PCLK}/3$ ) MHz for the slave mode
- FIFO Depth: 8 levels
- Multi-master and multi-slave operation

The Serial Peripheral Interface, SPI, provides an SPI protocol data transmit and receive function in both master and slave modes. The SPI interface uses 4 pins, among which are serial data input and output lines MISO and MOSI, the clock line SCK, and the slave select line SEL. One SPI device acts as a master who controls the data flow using the SEL and SCK signals to indicate the start of the data communication and the data sampling rate. To receive the data bits, the streamlined data bits are latched on a specific clock edge and stored in the data register or in the RX FIFO. Data transmission is carried out in a similar way but with the reverse sequence. The mode fault detection provides a capability for multi-master applications.

## Universal Asynchronous Receiver Transmitter – UART

- Asynchronous serial communication operating baud-rate clock frequency up to ( $f_{PCLK}/16$ ) MHz
- Full duplex communication
- Fully programmable serial communication characteristics including:
  - Word length: 7, 8 or 9-bit character
  - Parity: Even, odd or no-parity bit generation and detection
  - Stop bit: 1 or 2 stop bits generation
  - Bit order: LSB-first or MSB-first transfer
- Error detection: Parity, overrun and frame error

The Universal Asynchronous Receiver Transceiver, UART, provides a flexible full duplex data exchange using asynchronous transfer. The UART is used to translate data between parallel and serial interfaces, and is commonly used for RS232 standard communication. The UART peripheral function supports Line Status Interrupt. The software can detect a UART error status by reading the UART Status & Interrupt Flag Register, URSIFR. The status includes the type and the condition of transfer operations as well as several error conditions resulting from Parity, Overrun, Framing and Break events.

## Universal Synchronous Asynchronous Receiver Transmitter – USART

- Supports both asynchronous and clocked synchronous serial communication modes
- Programmable baud rate clock frequency up to ( $f_{PCLK}/16$ ) MHz for Asynchronous mode and ( $f_{PCLK}/8$ ) MHz for synchronous mode
- Full duplex communication
- Fully programmable serial communication characteristics including:
  - Word length: 7, 8 or 9-bit character
  - Parity: Even, odd or no-parity bit generation and detection
  - Stop bit: 1 or 2 stop bits generation
  - Bit order: LSB-first or MSB-first transfer
- Error detection: Parity, overrun and frame error
- Auto hardware flow control mode – RTS, CTS
- IrDA SIR encoder and decoder
- RS485 mode with output enable control
- FIFO Depth: 8-level for both receiver and transmitter

The Universal Synchronous Asynchronous Receiver Transceiver, USART, provides a flexible full duplex data exchange using synchronous or asynchronous transfer. The USART is used to translate data between parallel and serial interfaces, and is commonly used for RS232 standard communication. The USART peripheral function supports four types of interrupt including Line Status Interrupt, Transmitter FIFO Empty Interrupt, Receiver Threshold Level Reaching Interrupt and Time Out Interrupt. The USART module includes an 8-level transmitter FIFO, (TX\_FIFO) and an 8-level receiver FIFO (RX\_FIFO). The software can detect a USART error status by reading USART Status & Interrupt Flag Register, USRSIFR. The status includes the type and the condition of transfer operations as well as several error conditions resulting from Parity, Overrun, Framing and Break events.

## Cyclic Redundancy Check – CRC

- Supports CRC16 polynomial: 0x8005,  
 $X^{16}+X^{15}+X^2+1$
- Supports CCITT CRC16 polynomial: 0x1021,  
 $X^{16}+X^{12}+X^5+1$
- Supports IEEE-802.3 CRC32 polynomial: 0x04C11DB7,  
 $X^{32}+X^{26}+X^{23}+X^{22}+X^{16}+X^{12}+X^{11}+X^{10}+X^8+X^7+X^5+X^4+X^2+X+1$
- Supports 1's complement, byte reverse & bit reverse operation on data and checksum
- Supports byte, half-word & word data size
- Programmable CRC initial seed value
- CRC computation done in 1 AHB clock cycle for 8-bit data and 4 AHB clock cycles for 32-bit data
- Supports PDMA to complete a CRC computation of a block of memory

The CRC calculation unit is an error detection technique test algorithm and is used to verify data transmission or storage data correctness. A CRC calculation takes a data stream or a block of data as its input and generates a 16-bit or 32-bit output remainder. Ordinarily, a data stream is suffixed by a CRC code and used as a checksum when being sent or stored. Therefore, the received or

restored data stream is calculated by the same generator polynomial as described above. If the new CRC code result does not match the one calculated earlier, that means the data stream contains a data error.

## Peripheral Direct Memory Access – PDMA

- 6 channels with trigger source grouping
- 8-bit, 16-bit and 32-bit width data transfer
- Supports Linear address, circular address and fixed address modes
- 4-level programmable channel priority
- Auto reload mode
- Supports trigger sources:  
ADC, SPI, USART, UART, I<sup>2</sup>C, MCTM, GPTM, SCTM and software request

The Peripheral Direct Memory Access circuitry, PDMA, moves data between the peripherals and the system memory on the AHB bus. Each PDMA channel has a source address, destination address, block length and transfer count. The PDMA can exclude the CPU intervention and avoid interrupt service routine execution. It improves system performance as the software does not need to connect each data movement operation.

## Hardware Divider – DIV

- Signed/unsigned 32-bit divider
- Calculate in 8 clock cycles, load in 1 clock cycle
- Division by zero error Flag

The divider is the truncated division and requires a software triggered start signal by controlling the “START” bit in the control register. The divider calculation complete flag will be set to 1 after 8 clock cycles, however, if the divisor register data is zero during the calculation, the division by zero error flag will be set to 1.

## Debug Support

- Serial Wire Debug Port – SW-DP
- 4 comparators for hardware breakpoint or code / literal patch
- 2 comparators for hardware watchpoints

## Package and Operation Temperature

- 48-pin LQFP package
- Operation temperature range: -40 °C to 105 °C

# 4 Overview

## Device Information

**Table 1. Features and Peripheral List**

Peripherals		HT32F65230	HT32F65240
Main Flash (KB)		31	63
Option Bytes Flash (KB)			1
SRAM (KB)		4	8
Timers	MCTM		1
	GPTM		1
	SCTM		4
	BFTM		2
	WDT		1
	RTC		1
Communication	USART		1
	UART		1
	SPI		1
	I <sup>2</sup> C		1
PDMA			6 channels
Hardware Divider			1
CRC-16/32			1
EXTI			16
12-bit ADC			2
Number of channels			8 channels
Comparator			3
Operational Amplifier			2
GPIO			Up to 40
CPU frequency			Up to 60 MHz
Operating voltage			2.5 V ~ 5.5 V
Operating temperature			-40 °C ~ 105 °C
Package			48-pin LQFP



## Block Diagram

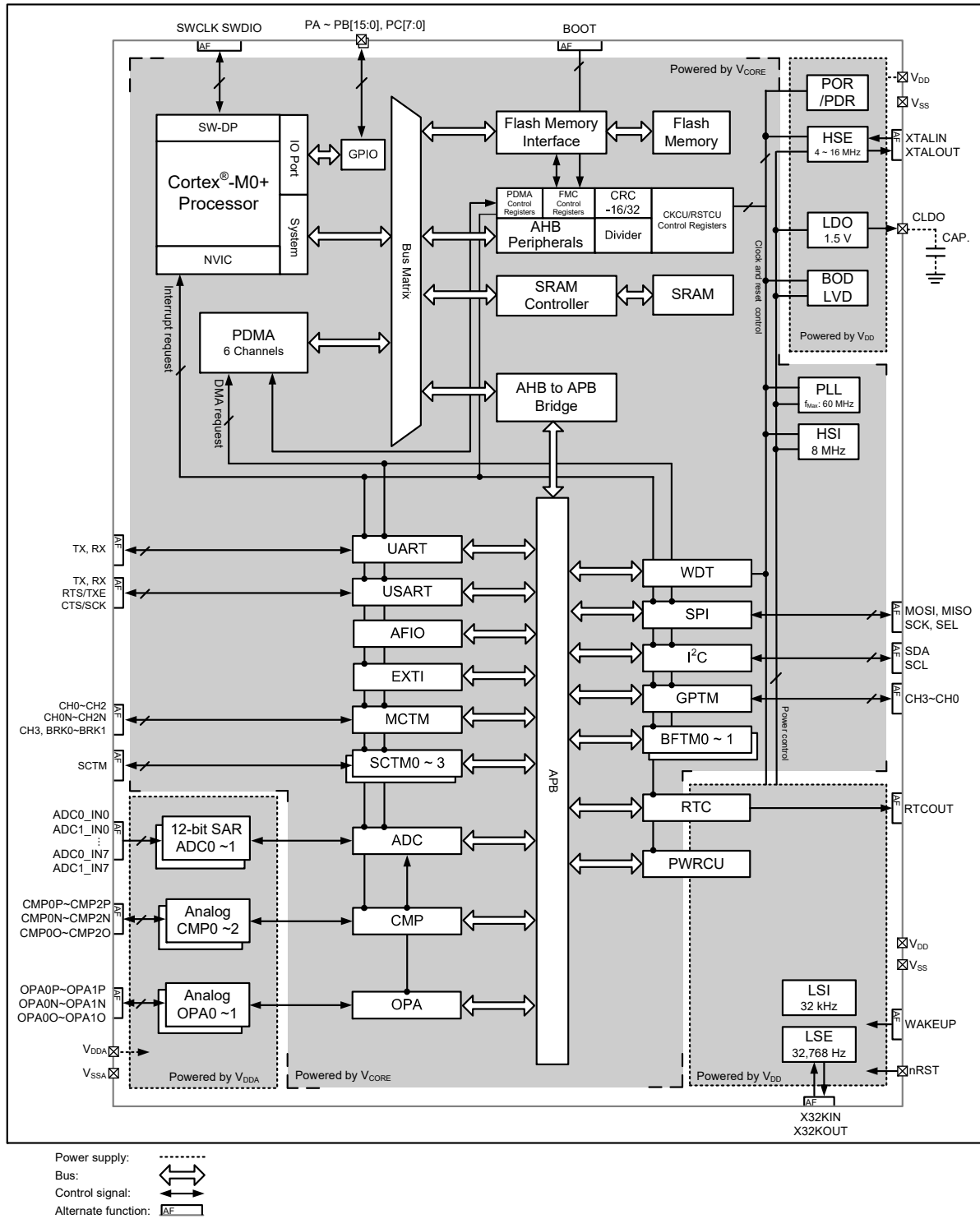

Figure 1. Block Diagram

## Memory Map

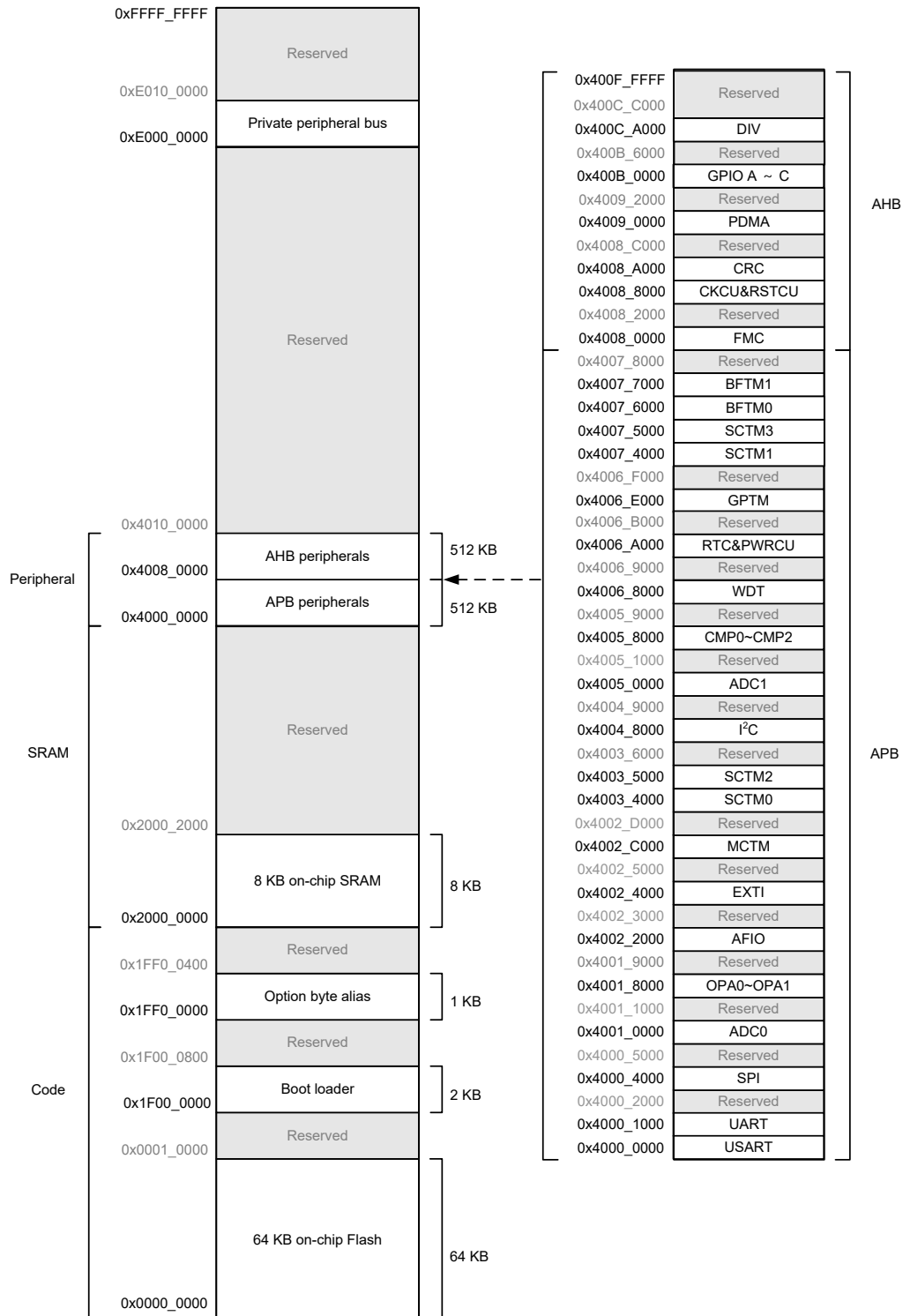

Figure 2. Memory Map

**Table 2. Register Map**

Start Address	End Address	Peripheral	Bus
0x4000_0000	0x4000_0FFF	USART	APB
0x4000_1000	0x4000_1FFF	UART	
0x4000_2000	0x4000_3FFF	Reserved	
0x4000_4000	0x4000_4FFF	SPI	
0x4000_5000	0x4000_FFFF	Reserved	
0x4001_0000	0x4001_0FFF	ADC0	
0x4001_1000	0x4001_7FFF	Reserved	
0x4001_8000	0x4001_8FFF	OPA0 ~ OPA1	
0x4001_9000	0x4002_1FFF	Reserved	
0x4002_2000	0x4002_2FFF	AFIO	
0x4002_3000	0x4002_3FFF	Reserved	
0x4002_4000	0x4002_4FFF	EXTI	
0x4002_5000	0x4002_BFFF	Reserved	
0x4002_C000	0x4002_CFFF	MCTM	
0x4002_D000	0x4003_3FFF	Reserved	
0x4003_4000	0x4003_4FFF	SCTM0	
0x4003_5000	0x4003_5FFF	SCTM2	
0x4003_6000	0x4004_7FFF	Reserved	
0x4004_8000	0x4004_8FFF	I <sup>2</sup> C	
0x4004_9000	0x4004_FFFF	Reserved	
0x4005_0000	0x4005_0FFF	ADC1	
0x4005_1000	0x4005_7FFF	Reserved	
0x4005_8000	0x4005_8FFF	CMP0 ~ CMP2	
0x4005_9000	0x4006_7FFF	Reserved	
0x4006_8000	0x4006_8FFF	WDT	
0x4006_9000	0x4006_9FFF	Reserved	
0x4006_A000	0x4006_AFFF	RTC&PWRCU	
0x4006_B000	0x4006_DFFF	Reserved	
0x4006_E000	0x4006_EFFF	GPTM	
0x4006_F000	0x4007_3FFF	Reserved	
0x4007_4000	0x4007_4FFF	SCTM1	
0x4007_5000	0x4007_5FFF	SCTM3	
0x4007_6000	0x4007_6FFF	BFTM0	
0x4007_7000	0x4007_7FFF	BFTM1	
0x4007_8000	0x4007_FFFF	Reserved	

Start Address	End Address	Peripheral	Bus
0x4008_0000	0x4008_1FFF	FMC	AHB
0x4008_2000	0x4008_7FFF	Reserved	
0x4008_8000	0x4008_9FFF	CKCU&RSTCU	
0x4008_A000	0x4008_BFFF	CRC	
0x4008_C000	0x4008_FFFF	Reserved	
0x4009_0000	0x4009_1FFF	PDMA	
0x4009_2000	0x400A_FFFF	Reserved	
0x400B_0000	0x400B_1FFF	GPIOA	
0x400B_2000	0x400B_3FFF	GPIOB	
0x400B_4000	0x400B_5FFF	GPIOC	
0x400B_6000	0x400C_9FFF	Reserved	
0x400C_A000	0x400C_BFFF	DIV	
0x400C_C000	0x400F_FFFF	Reserved	

## Clock Structure

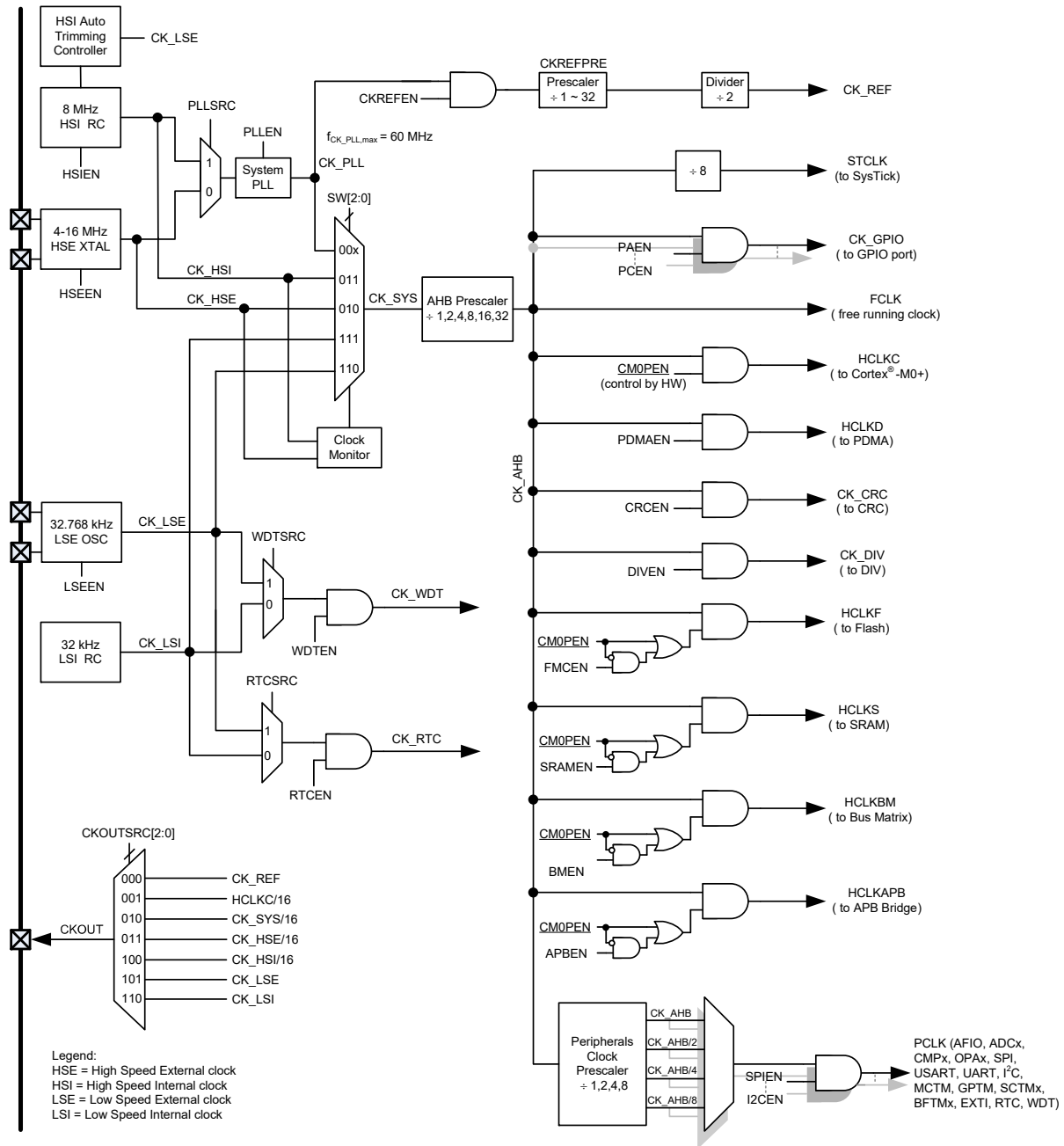
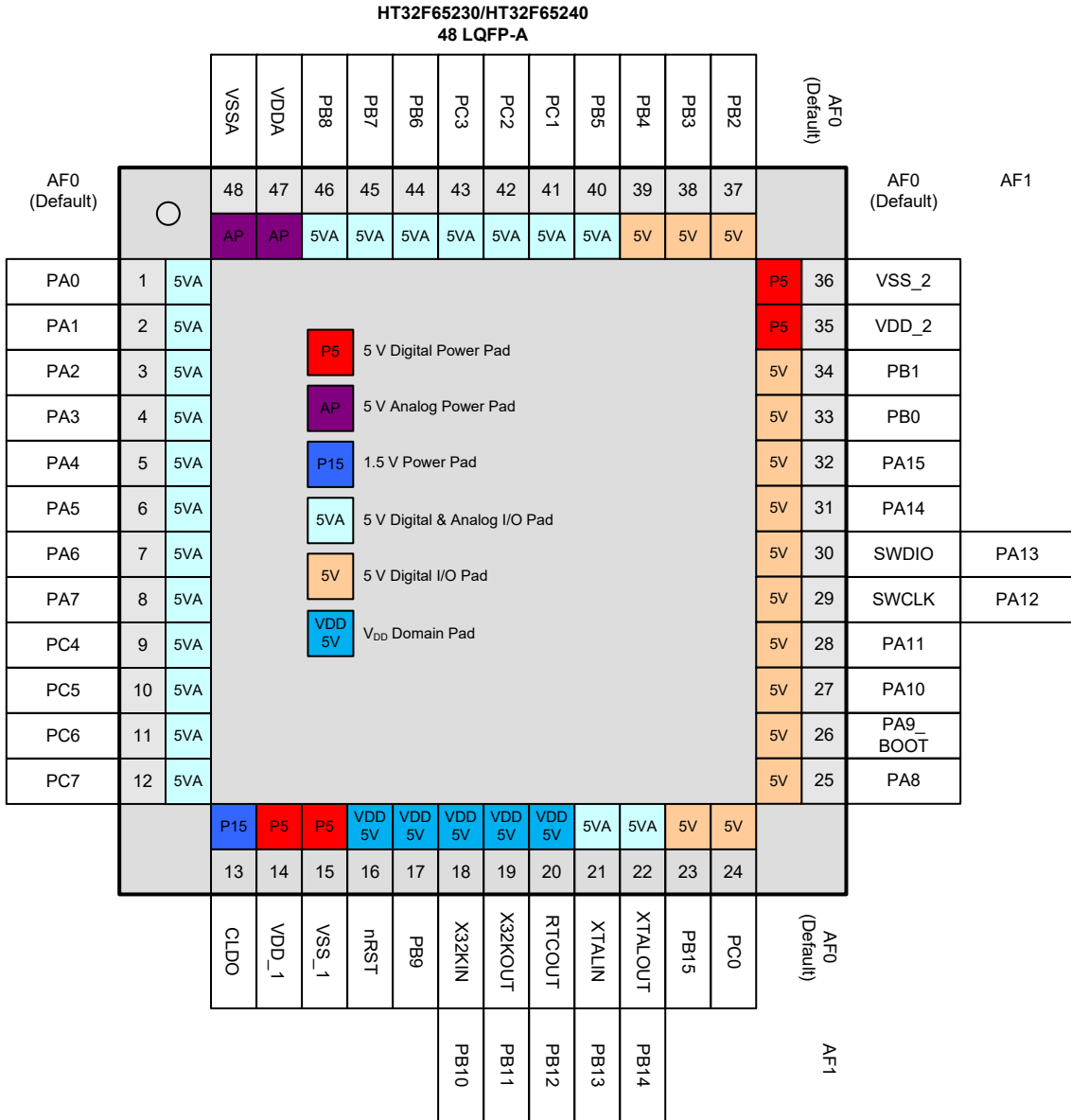

Figure 3. Clock Structure

# 5 Pin Assignment



**Figure 4. 48-pin LQFP Pin Assignment**

**Table 3. Pin Alternate Function**

Package	Alternate Function Mapping															
	AF0	AF1	AF2	AF3	AF4	AF5	AF6	AF7	AF8	AF9	AF10	AF11	AF12	AF13	AF14	AF15
48 LQFP	System Default	GPIO	ADC0	ADC1	GPTM /MCTM	SPI	USART /UART	I <sup>2</sup> C	CMP /OPA	N/A	N/A	N/A	N/A	SCTM	N/A	System Other
1	PA0		ADC0_IN5	ADC1_IN1										SCTM0		
2	PA1		ADC0_IN6	ADC1_IN2			USR_RX							SCTM1		
3	PA2		ADC0_IN7	ADC1_IN3	MT_BRK0	SPI_SCK										
4	PA3			ADC1_IN4	MT_BRK1	SPI_SEL	USR_TX		CMP00							
5	PA4			ADC1_IN5		SPI_MISO	UR_TX	I2C_SCL	CMP10					SCTM2		
6	PA5			ADC1_IN6		SPI_MOSI	UR_RX	I2C_SDA	CMP20					SCTM3		
7	PA6			ADC1_IN7					CMP0P							
8	PA7				GT_CH0	SPI_SEL			CMP0N							
9	PC4				GT_CH1		USR_RTS		CMP1P							
10	PC5				GT_CH2	SPI_SCK	USR_CTS		CMP1N					SCTM0		
11	PC6				GT_CH3	SPI_MOSI	UR_TX		CMP2P							
12	PC7					SPI_MISO	UR_RX		CMP2N					SCTM3		
13	CLDO															
14	VDD_1															
15	VSS_1															
16	nRST															
17	PB9					SPI_SCK	USR_RTS	I2C_SCL						SCTM1		
18	X32KIN	PB10					UR_RX	I2C_SCL								
19	X32KOUT	PB11					UR_TX	I2C_SDA								
20	RTCOUT	PB12				SPI_SEL	USR_TX							SCTM0		WAKEUP
21	XTALIN	PB13														
22	XTALOUT	PB14														
23	PB15				MT_BRK0	SPI_MOSI	USR_CTS	I2C_SDA						SCTM2		
24	PC0					SPI_MISO	USR_RX							SCTM3		
25	PA8				GT_CH0		USR_RX									
26	PA9_BOOT				GT_CH3		USR_TX									CKOUT
27	PA10				GT_CH1		USR_RTS	I2C_SCL						SCTM1		
28	PA11				GT_CH2		USR_CTS	I2C_SDA						SCTM2		
29	SWCLK	PA12														
30	SWDIO	PA13														
31	PA14				MT_CH2N											
32	PA15				MT_CH2											
33	PB0				MT_CH1N											
34	PB1				MT_CH1											
35	VDD_2															
36	VSS_2															
37	PB2				MT_CH0N											
38	PB3				MT_CH0											
39	PB4				MT_BRK1		UR_RX							SCTM3		
40	PB5					SPI_SEL			OPA00							
41	PC1					SPI_SCK			OPA0N					SCTM0		
42	PC2		ADC0_IN0			SPI_MOSI			OPA0P					SCTM1		
43	PC3		ADC0_IN1			SPI_MISO			OPA10							
44	PB6		ADC0_IN2		MT_BRK0			I2C_SCL	OPA1N					SCTM2		
45	PB7		ADC0_IN3		MT_BRK1			I2C_SDA	OPA1P							
46	PB8		ADC0_IN4	ADC1_IN0	MT_CH3		UR_TX									
47	VDDA															
48	VSSA															

**Table 4. Pin Description**

Pin Number 48LQFP	Pin Name	Type <sup>(1)</sup>	I/O Structure <sup>(2)</sup>	Output Driving	Description
					Default function (AF0)
1	PA0	AI/O	5V	4/8/12/16 mA	PA0
2	PA1	AI/O	5V	4/8/12/16 mA	PA1
3	PA2	AI/O	5V	4/8/12/16 mA	PA2
4	PA3	AI/O	5V	4/8/12/16 mA	PA3
5	PA4	AI/O	5V	4/8/12/16 mA	PA4, this pin provides a UART_TX function in the Boot loader mode
6	PA5	AI/O	5V	4/8/12/16 mA	PA5, this pin provides a UART_RX function in the Boot loader mode
7	PA6	AI/O	5V	4/8/12/16 mA	PA6
8	PA7	AI/O	5V	4/8/12/16 mA	PA7
9	PC4	AI/O	5V	4/8/12/16 mA	PC4
10	PC5	AI/O	5V	4/8/12/16 mA	PC5
11	PC6	AI/O	5V	4/8/12/16 mA	PC6
12	PC7	AI/O	5V	4/8/12/16 mA	PC7
13	CLDO	P	—	—	Core power LDO 1.5 V output A 2.2µF capacitor must be connected as close as possible between this pin and VSS_1
14	VDD_1	P	—	—	Voltage for digital I/O
15	VSS_1	P	—	—	Ground reference for digital I/O
16	nRST <sup>(3)</sup>	I	5V_PU	—	External reset pin
17	PB9 <sup>(3)</sup>	I/O (V <sub>DD</sub> )	5V	4/8/12/16 mA	PB9
18	PB10 <sup>(3)</sup>	AI/O (V <sub>DD</sub> )	5V	4/8/12/16 mA	X32KIN
19	PB11 <sup>(3)</sup>	AI/O (V <sub>DD</sub> )	5V	4/8/12/16 mA	X32KOUT
20	PB12 <sup>(3)</sup>	I/O (V <sub>DD</sub> )	5V	4/8/12/16 mA	RTCOUT
21	PB13	AI/O	5V	4/8/12/16 mA	XTALIN
22	PB14	AI/O	5V	4/8/12/16 mA	XTALOUT
23	PB15	I/O	5V	4/8/12/16 mA	PB15
24	PC0	I/O	5V	4/8/12/16 mA	PC0
25	PA8	I/O	5V	4/8/12/16 mA	PA8
26	PA9	I/O	5V_PU	4/8/12/16 mA	PA9_BOOT
27	PA10	I/O	5V	4/8/12/16 mA	PA10
28	PA11	I/O	5V	4/8/12/16 mA	PA11
29	PA12	I/O	5V_PU	4/8/12/16 mA	SWCLK
30	PA13	I/O	5V_PU	4/8/12/16 mA	SWDIO
31	PA14	I/O	5V	4/8/12/16 mA	PA14
32	PA15	I/O	5V	4/8/12/16 mA	PA15
33	PB0	I/O	5V	4/8/12/16 mA	PB0



Pin Number 48LQFP	Pin Name	Type <sup>(1)</sup>	I/O Structure <sup>(2)</sup>	Output Driving	Description
					Default function (AF0)
34	PB1	I/O	5V	4/8/12/16 mA	PB1
35	VDD_2	P	—	—	Voltage for digital I/O
36	VSS_2	P	—	—	Ground reference for digital I/O
37	PB2	I/O	5V	4/8/12/16 mA	PB2
38	PB3	I/O	5V	4/8/12/16 mA	PB3
39	PB4	I/O	5V	4/8/12/16 mA	PB4
40	PB5	AI/O	5V	4/8/12/16 mA	PB5
41	PC1	AI/O	5V	4/8/12/16 mA	PC1
42	PC2	AI/O	5V	4/8/12/16 mA	PC2
43	PC3	AI/O	5V	4/8/12/16 mA	PC3
44	PB6	AI/O	5V	4/8/12/16 mA	PB6
45	PB7	AI/O	5V	4/8/12/16 mA	PB7
46	PB8	AI/O	5V	4/8/12/16 mA	PB8
47	VDDA	P	—	—	Analog voltage for ADC and Comparator
48	VSSA	P	—	—	Ground reference for ADC and Comparator

Note: 1. I = Input, O = Output, A = Analog Port, P = Power Supply,  $V_{DD} = V_{DD}$  Power.  
 2. 5V = 5 V operation I/O type, PU = Pull-up.  
 3. These pins are located at the  $V_{DD}$  power domain.

# 6 Electrical Characteristics

## Absolute Maximum Ratings

The following table shows the absolute maximum ratings of the device. These are stress ratings only. Stresses beyond absolute maximum ratings may cause permanent damage to the device. Note that the device is not guaranteed to operate properly at the maximum ratings. Exposure to the absolute maximum rating conditions for extended periods may affect device reliability.

**Table 5. Absolute Maximum Ratings**

Symbol	Parameter	Min.	Max.	Unit
V <sub>DD</sub>	External Main Supply Voltage	V <sub>SS</sub> - 0.3	V <sub>SS</sub> + 5.5	V
V <sub>DDA</sub>	External Analog Supply Voltage	V <sub>SSA</sub> - 0.3	V <sub>SSA</sub> + 5.5	V
V <sub>IN</sub>	Input Voltage on I/O	V <sub>SS</sub> - 0.3	V <sub>DD</sub> + 0.3	V
T <sub>A</sub>	Ambient Operating Temperature Range	-40	105	°C
T <sub>STG</sub>	Storage Temperature Range	-60	150	°C
T <sub>J</sub>	Maximum Junction Temperature	—	125	°C
P <sub>D</sub>	Total Power Dissipation	—	500	mW
V <sub>ESD</sub>	Electrostatic Discharge Voltage – Human Body Mode	-4000	4000	V

## Recommended DC Operating Conditions

**Table 6. Recommended DC Operating Conditions**

T<sub>A</sub> = 25 °C, unless otherwise specified.

Symbol	Parameter	Conditions	Min.	Typ.	Max.	Unit
V <sub>DD</sub>	Operating Voltage	—	2.5	5.0	5.5	V
V <sub>DDA</sub>	Analog Operating Voltage	—	2.5	5.0	5.5	V

## On-Chip LDO Voltage Regulator Characteristics

**Table 7. LDO Characteristics**

T<sub>A</sub> = 25 °C, unless otherwise specified.

Symbol	Parameter	Conditions	Min.	Typ.	Max.	Unit
V <sub>LDO</sub>	Internal Regulator Output Voltage	V <sub>DD</sub> ≥ 2.5 V Regulator input @ I <sub>LDO</sub> = 35 mA and voltage variation = ±5 %, After trimming	1.425	1.5	1.57	V
I <sub>LDO</sub>	Output Current	V <sub>DD</sub> = 2.5 V Regulator input @ V <sub>LDO</sub> = 1.5 V	—	30	35	mA
C <sub>LDO</sub>	External Filter Capacitor Value for Internal Core Power Supply	The capacitor value is dependent on the core power current consumption	1	2.2	—	μF

## Power Consumption

Table 8. Power Consumption Characteristics

T<sub>A</sub> = 25 °C, unless otherwise specified.

Symbol	Parameter	Conditions	Min.	Typ.	Max.	Unit	
I <sub>DD</sub>	Supply Current (Run Mode)	V <sub>DD</sub> = 5.0 V, HSI = 8 MHz, PLL = 60 MHz, f <sub>HCLK</sub> = 60 MHz, f <sub>PCLK</sub> = 60 MHz, all peripherals enabled	—	16.76	—	mA	
		V <sub>DD</sub> = 5.0 V, HSI = 8 MHz, PLL = 60 MHz, f <sub>HCLK</sub> = 60 MHz, f <sub>PCLK</sub> = 60 MHz, all peripherals disabled	—	7.54	—	mA	
		V <sub>DD</sub> = 5.0 V, HSI = 8 MHz, PLL = 40 MHz, f <sub>HCLK</sub> = 40 MHz, f <sub>PCLK</sub> = 40 MHz, all peripherals enabled	—	13.9	—	mA	
		V <sub>DD</sub> = 5.0 V, HSI = 8 MHz, PLL = 40 MHz, f <sub>HCLK</sub> = 40 MHz, f <sub>PCLK</sub> = 40 MHz, all peripherals disabled	—	7.69	—	mA	
		V <sub>DD</sub> = 5.0 V, HSI = 8 MHz, PLL = 20 MHz, f <sub>HCLK</sub> = 20 MHz, f <sub>PCLK</sub> = 20 MHz, all peripherals enabled	—	6.56	—	mA	
		V <sub>DD</sub> = 5.0 V, HSI = 8 MHz, PLL = 20 MHz, f <sub>HCLK</sub> = 20 MHz, f <sub>PCLK</sub> = 20 MHz, all peripherals disabled	—	3.44	—	mA	
		V <sub>DD</sub> = 5.0 V, HSI = 8 MHz, PLL off, f <sub>HCLK</sub> = 8 MHz, f <sub>PCLK</sub> = 8 MHz, all peripherals enabled	—	2.69	—	mA	
		V <sub>DD</sub> = 5.0 V, HSI = 8 MHz, PLL off, f <sub>HCLK</sub> = 8 MHz, f <sub>PCLK</sub> = 8 MHz, all peripherals disabled	—	1.43	—	mA	
		V <sub>DD</sub> = 5.0 V, HSI off, PLL off, LSI on, f <sub>HCLK</sub> = 32 kHz, f <sub>PCLK</sub> = 32 kHz, all peripherals enabled	—	34.6	—	μA	
		V <sub>DD</sub> = 5.0 V, HSI off, PLL off, LSI on, f <sub>HCLK</sub> = 32 kHz, f <sub>PCLK</sub> = 32 kHz, all peripherals disabled	—	29.6	—	μA	
		Supply Current (Sleep Mode)	V <sub>DD</sub> = 5.0 V, HSI = 8 MHz, PLL = 60 MHz, f <sub>HCLK</sub> = 0 MHz, f <sub>PCLK</sub> = 60 MHz, all peripherals enabled	—	11.22	—	mA
			V <sub>DD</sub> = 5.0 V, HSI = 8 MHz, PLL = 60 MHz, f <sub>HCLK</sub> = 0 MHz, f <sub>PCLK</sub> = 60 MHz, all peripherals disabled	—	1.19	—	mA
			V <sub>DD</sub> = 5.0 V, HSI = 8 MHz, PLL = 40 MHz, f <sub>HCLK</sub> = 0 MHz, f <sub>PCLK</sub> = 40 MHz, all peripherals enabled	—	7.63	—	mA
			V <sub>DD</sub> = 5.0 V, HSI = 8 MHz, PLL = 40 MHz, f <sub>HCLK</sub> = 0 MHz, f <sub>PCLK</sub> = 40 MHz, all peripherals disabled	—	0.94	—	mA
V <sub>DD</sub> = 5.0 V, HSI = 8 MHz, PLL = 20 MHz, f <sub>HCLK</sub> = 0 MHz, f <sub>PCLK</sub> = 20 MHz, all peripherals enabled	—		4.16	—	mA		

Symbol	Parameter	Conditions	Min.	Typ.	Max.	Unit
I <sub>DD</sub>	Supply Current (Sleep Mode)	V <sub>DD</sub> = 5.0 V, HSI = 8 MHz, PLL = 20 MHz, f <sub>HCLK</sub> = 0 MHz, f <sub>PCLK</sub> = 20 MHz, all peripherals disabled	—	0.73	—	mA
		V <sub>DD</sub> = 5.0 V, HSI = 8 MHz, PLL off, f <sub>HCLK</sub> = 0 MHz, f <sub>PCLK</sub> = 8 MHz, all peripherals enabled	—	1.72	—	mA
		V <sub>DD</sub> = 5.0 V, HSI = 8 MHz, PLL off, f <sub>HCLK</sub> = 0 MHz, f <sub>PCLK</sub> = 8 MHz, all peripherals disabled	—	0.35	—	mA
	Supply Current (Deep-Sleep Mode)	V <sub>DD</sub> = 5.0 V, all clock off (HSE/HSI/LSE), LDO in low power mode, LSI on, RTC on	—	25	—	μA

- Note: 1. HSE means high speed external oscillator. HSI means 8 MHz high speed internal oscillator.  
2. LSE means 32.768 kHz low speed external oscillator. LSI means 32 kHz low speed internal oscillator.  
3. Code = while (1) { 208 NOP } executed in Flash.

## Reset and Supply Monitor Characteristics

Table 9. V<sub>DD</sub> Power Reset Characteristics

T<sub>A</sub> = 25 °C, unless otherwise specified.

Symbol	Parameter	Conditions	Min.	Typ.	Max.	Unit
V <sub>POR</sub>	Power On Reset Threshold (Rising Voltage on V <sub>DD</sub> )	T <sub>A</sub> = -40 °C ~ 105 °C	2.22	2.35	2.48	V
V <sub>PDR</sub>	Power Down Reset Threshold (Falling Voltage on V <sub>DD</sub> )		2.09	2.2	2.33	V
V <sub>PORHYST</sub>	POR Hysteresis	—	—	150	—	mV
t <sub>POR</sub>	Reset Delay Time	V <sub>DD</sub> = 5.0 V	—	0.1	0.2	ms

- Note: 1. Data based on characterization results only, not tested in production.  
2. Guaranteed by design, not tested in production.  
3. If the LDO is turned on, the V<sub>DD</sub> POR has to be in the de-assertion condition. When the V<sub>DD</sub> POR is in the assertion state then the LDO will be turned off.

**Table 10. LVD/BOD Characteristics**

$T_A = 25\text{ }^\circ\text{C}$ , unless otherwise specified.

Symbol	Parameter	Conditions	Min.	Typ.	Max.	Unit	
$V_{BOD}$	Voltage of Brown-Out Detection	After factory-trimmed $V_{DD}$ Falling edge	2.37	2.45	2.53	V	
$V_{LVD}$	Voltage of Low Voltage Detection	$V_{DD}$ Falling edge	LVDS = 000	2.57	2.65	2.73	V
			LVDS = 001	2.77	2.85	2.93	V
			LVDS = 010	2.97	3.05	3.13	V
			LVDS = 011	3.17	3.25	3.33	V
			LVDS = 100	3.37	3.45	3.53	V
			LVDS = 101	4.15	4.25	4.35	V
			LVDS = 110	4.35	4.45	4.55	V
	LVDS = 111	4.55	4.65	4.75	V		
$V_{LVDHTST}$	LVD Hysteresis	$V_{DD} = 5.0\text{ V}$	—	—	100	mV	
$t_{suLVD}$	LVD Setup Time	$V_{DD} = 5.0\text{ V}$	—	—	5	$\mu\text{s}$	
$t_{aiLVD}$	LVD Active Delay Time	$V_{DD} = 5.0\text{ V}$	—	—	—	ms	
$I_{DDLVD}$	Operation Current <sup>(3)</sup>	$V_{DD} = 5.0\text{ V}$	—	—	10	$\mu\text{A}$	

Note: 1. Data based on characterization results only, not tested in production.

2. Guaranteed by design, not tested in production.

3. Bandgap current is not included.

4. LVDS field is in the PWRCU LVDCSR register.

## External Clock Characteristics

**Table 11. High Speed External Clock (HSE) Characteristics**

$T_A = 25\text{ }^\circ\text{C}$ , unless otherwise specified.

Symbol	Parameter	Conditions	Min.	Typ.	Max.	Unit
$V_{DD}$	Operation Range	—	2.5	—	5.5	V
$f_{HSE}$	HSE Frequency	—	4	—	16	MHz
$C_L$	Load Capacitance	$V_{DD} = 5.0\text{ V}$ , $R_{ESR} = 100\ \Omega$ @ 16 MHz	—	—	22	pF
$R_{FHSE}$	Internal Feedback Resistor between XTALIN and XTALOUT pins	—	—	0.5	—	M $\Omega$
$R_{ESR}$	Equivalent Series Resistance	$V_{DD} = 5.0\text{ V}$ , $C_L = 12\text{ pF}$ @ 16 MHz, HSEDR = 0	—	—	160	$\Omega$
		$V_{DD} = 2.5\text{ V}$ , $C_L = 12\text{ pF}$ @ 16 MHz, HSEDR = 1	—	—	—	—
$D_{HSE}$	HSE Oscillator Duty Cycle	—	40	—	60	%
$I_{DDHSE}$	HSE Oscillator Current Consumption	$V_{DD} = 5.0\text{ V}$ @ 16 MHz	—	TBD	—	mA
$I_{PWDHSE}$	HSE Oscillator Power Down Current	$V_{DD} = 5.0\text{ V}$	—	—	0.01	$\mu\text{A}$
$t_{SUHSE}$	HSE Oscillator Startup Time	$V_{DD} = 5.0\text{ V}$	—	—	4	ms

**Table 12. Low Speed External Clock (LSE) Characteristics**

$T_A = 25\text{ }^\circ\text{C}$ , unless otherwise specified.

Symbol	Parameter	Conditions	Min.	Typ.	Max.	Unit
$V_{DD}$	Operation Range	—	2.5	—	5.5	V
$f_{CK\_LSE}$	LSE Frequency	$V_{DD} = 2.5\text{ V} \sim 5.5\text{ V}$	—	32.768	—	kHz
$R_F$	Internal Feedback Resistor	—	—	10	—	MΩ
$R_{ESR}$	Equivalent Series Resistance	$V_{DD} = 5.0\text{ V}$	30	—	TBD	kΩ
$C_L$	Recommended Load Capacitances	$V_{DD} = 5.0\text{ V}$	6	—	TBD	pF
$I_{DDLSE}$	Oscillator Supply Current (High Current Mode)	$f_{CK\_LSE} = 32.768\text{ kHz}$ , $R_{ESR} = 50\text{ k}\Omega$ , $C_L \geq 7\text{ pF}$ $V_{DD} = 2.5 \sim 5.5\text{ V}$ $T_A = -40\text{ }^\circ\text{C} \sim 105\text{ }^\circ\text{C}$	—	5.0	6.3	$\mu\text{A}$
	Oscillator Supply Current (Low Current Mode)	$f_{CK\_LSE} = 32.768\text{ kHz}$ , $R_{ESR} = 50\text{ k}\Omega$ , $C_L < 7\text{ pF}$ $V_{DD} = 2.5\text{ V} \sim 5.5\text{ V}$ $T_A = -40\text{ }^\circ\text{C} \sim 105\text{ }^\circ\text{C}$	—	1.8	5.0	$\mu\text{A}$
	Power Down Current	—	—	—	0.01	$\mu\text{A}$
$t_{SULSE}$	LSE Oscillator Startup Time (Low Current Mode)	$f_{CK\_LSE} = 32.768\text{ kHz}$ , $V_{DD} = 2.5\text{ V} \sim 5.5\text{ V}$	500	—	—	ms

Note: The following guidelines are recommended to increase the stability of the crystal circuit of the HSE / LSE clock in the PCB layout.

1. The crystal oscillator should be located as close as possible to the MCU to keep the trace length as short as possible to reduce the parasitic capacitance.
2. Shield lines in the vicinity of the crystal by using a ground plane to isolate signals and reduce noise.
3. Keep the high frequency signal lines away from the crystal area to prevent the crosstalk adverse effects.

## Internal Clock Characteristics

**Table 13. High Speed Internal Clock (HSI) Characteristics**

$T_A = 25\text{ }^\circ\text{C}$ , unless otherwise specified.

Symbol	Parameter	Conditions	Min.	Typ.	Max.	Unit
$V_{DD}$	Operation Range	$T_A = -40\text{ }^\circ\text{C} \sim 105\text{ }^\circ\text{C}$	2.5	—	5.5	V
$f_{HSI}$	HSI Frequency	$V_{DD} = 5.0\text{ V} @ 25\text{ }^\circ\text{C}$	—	8	—	MHz
$ACC_{HSI}$	Factory Calibrated HSI Oscillator Frequency Accuracy	$V_{DD} = 5.0\text{ V}$ , $T_A = 25\text{ }^\circ\text{C}$	-2	—	+2	%
		$V_{DD} = 2.5\text{ V} \sim 5.5\text{ V}$ $T_A = -20\text{ }^\circ\text{C} \sim 85\text{ }^\circ\text{C}$	-3	—	+3	%
		$V_{DD} = 2.5\text{ V} \sim 5.5\text{ V}$ $T_A = 85\text{ }^\circ\text{C} \sim 105\text{ }^\circ\text{C}$	-3.5	—	+3.5	%
		$V_{DD} = 2.5\text{ V} \sim 5.5\text{ V}$ $T_A = -40\text{ }^\circ\text{C} \sim -20\text{ }^\circ\text{C}$	-5	—	+3.5	%
Duty	Duty Cycle	$f_{HSI} = 8\text{ MHz}$	35	—	65	%
$I_{DDHSI}$	Oscillator Supply Current	$f_{HSI} = 8\text{ MHz}$	—	300	500	$\mu\text{A}$
	Power Down Current		—	—	0.05	$\mu\text{A}$
$t_{SUHSI}$	HSI Oscillator Startup Time	$f_{HSI} = 8\text{ MHz}$	—	—	10	$\mu\text{s}$

**Table 14. Low Speed Internal Clock (LSI) Characteristics**

$T_A = 25\text{ }^\circ\text{C}$ , unless otherwise specified.

Symbol	Parameter	Conditions	Min.	Typ.	Max.	Unit
$V_{DD}$	Operation Range	—	2.5	—	5.5	V
$f_{LSI}$	LSI Frequency	$V_{DD} = 5.0\text{ V}$ , $T_A = -40\text{ }^\circ\text{C} \sim 105\text{ }^\circ\text{C}$	21	32	43	kHz
$ACC_{LSI}$	LSI Frequency Accuracy	After factory-trimmed, $V_{DD} = 5.0\text{ V}$ , $T_A = 25\text{ }^\circ\text{C}$	-10	—	+10	%
$I_{DDLSI}$	LSI Oscillator Operating Current	$V_{DD} = 5.0\text{ V}$ , $T_A = 25\text{ }^\circ\text{C}$	—	0.4	0.8	$\mu\text{A}$
$t_{SULSI}$	LSI Oscillator Startup Time	$V_{DD} = 5.0\text{ V}$ , $T_A = 25\text{ }^\circ\text{C}$	—	—	100	$\mu\text{s}$

## System PLL Characteristics

**Table 15. System PLL Characteristics**

$T_A = 25\text{ }^\circ\text{C}$ , unless otherwise specified.

Symbol	Parameter	Conditions	Min.	Typ.	Max.	Unit
$f_{PLLIN}$	System PLL Input Clock	—	4	—	16	MHz
$f_{CK\_PLL}$	System PLL Output Clock	—	16	—	60	MHz
$t_{LOCK}$	System PLL Lock Time	—	—	200	—	$\mu\text{s}$

## Memory Characteristics

**Table 16. Flash Memory Characteristics**

$T_A = 25\text{ }^\circ\text{C}$ , unless otherwise specified.

Symbol	Parameter	Conditions	Min.	Typ.	Max.	Unit
$N_{ENDU}$	Number of Guaranteed Program/ Erase Cycles before failure (Endurance)	$T_A = -40\text{ }^\circ\text{C} \sim 105\text{ }^\circ\text{C}$	10	—	—	K cycles
$t_{RET}$	Data Retention Time	$T_A = -40\text{ }^\circ\text{C} \sim 105\text{ }^\circ\text{C}$	10	—	—	Years
$t_{PROG}$	Word Programming Time	$T_A = -40\text{ }^\circ\text{C} \sim 105\text{ }^\circ\text{C}$	20	—	—	$\mu\text{s}$
$t_{ERASE}$	Page Erase Time	$T_A = -40\text{ }^\circ\text{C} \sim 105\text{ }^\circ\text{C}$	2	—	—	ms
$t_{MERASE}$	Mass Erase Time	$T_A = -40\text{ }^\circ\text{C} \sim 105\text{ }^\circ\text{C}$	10	—	—	ms

## I/O Port Characteristics

Table 17. I/O Port Characteristics

T<sub>A</sub> = 25 °C, unless otherwise specified.

Symbol	Parameter	Conditions	Min.	Typ.	Max.	Unit	
I <sub>IL</sub>	Low Level Input Current	5.0 V I/O	V <sub>I</sub> = V <sub>SS</sub> , On-chip pull-up resistor disabled	—	—	3	μA
		Reset pin		—	—	3	
I <sub>IH</sub>	High Level Input Current	5.0 V I/O	V <sub>I</sub> = V <sub>DD</sub> , On-chip pull-down resistor disabled	—	—	3	μA
		Reset pin		—	—	3	
V <sub>IL</sub>	Low Level Input Voltage	5.0 V I/O	-0.5	—	V <sub>DD</sub> × 0.35	V	
		Reset pin	-0.5	—	V <sub>DD</sub> × 0.35		
V <sub>IH</sub>	High Level Input Voltage	5.0 V I/O	V <sub>DD</sub> × 0.65	—	V <sub>DD</sub> + 0.5	V	
		Reset pin	V <sub>DD</sub> × 0.65	—	V <sub>DD</sub> + 0.5		
V <sub>HYS</sub>	Schmitt Trigger Input Voltage Hysteresis	5.0 V I/O	—	0.12 × V <sub>DD</sub>	—	mV	
		Reset pin	—	0.12 × V <sub>DD</sub>	—		
I <sub>OL</sub>	Low Level Output Current (GPIO Sink Current)	5.0 V I/O 4 mA drive, V <sub>OL</sub> = 0.4 V	4	—	—	mA	
		5.0 V I/O 8 mA drive, V <sub>OL</sub> = 0.4 V	8	—	—	mA	
		5.0 V I/O 12 mA drive, V <sub>OL</sub> = 0.4 V	12	—	—	mA	
		5.0 V I/O 16 mA drive, V <sub>OL</sub> = 0.4 V	16	—	—	mA	
		V <sub>DD</sub> Domain I/O drive @ V <sub>DD</sub> = 5.0 V, V <sub>OL</sub> = 0.4 V, PB9, PB10, PB11, PB12	4	—	—	mA	
I <sub>OH</sub>	High Level Output Current (GPIO Source Current)	5.0 V I/O 4 mA drive, V <sub>OH</sub> = V <sub>DD</sub> - 0.4 V	4	—	—	mA	
		5.0 V I/O 8 mA drive, V <sub>OH</sub> = V <sub>DD</sub> - 0.4 V	8	—	—	mA	
		5.0 V I/O 12 mA drive, V <sub>OH</sub> = V <sub>DD</sub> - 0.4 V	12	—	—	mA	
		5.0 V I/O 16 mA drive, V <sub>OH</sub> = V <sub>DD</sub> - 0.4 V	16	—	—	mA	
		V <sub>DD</sub> Domain I/O drive @ V <sub>DD</sub> = 5.0 V, V <sub>OH</sub> = V <sub>DD</sub> - 0.4 V, PB9, PB10, PB11, PB12	—	—	2	mA	
V <sub>OL</sub>	Low Level Output Voltage	5.0 V 4 mA drive I/O, I <sub>OL</sub> = 4 mA	—	—	0.4	V	
		5.0 V 8 mA drive I/O, I <sub>OL</sub> = 8 mA	—	—	0.4		
		5.0 V 12 mA drive I/O, I <sub>OL</sub> = 12 mA	—	—	0.4		
		5.0 V 16 mA drive I/O, I <sub>OL</sub> = 16 mA	—	—	0.4		



Symbol	Parameter	Conditions	Min.	Typ.	Max.	Unit
V <sub>OH</sub>	High Level Output Voltage	5.0 V 4 mA drive I/O, I <sub>OH</sub> = 4 mA	V <sub>DD</sub> - 0.4	—	—	V
		5.0 V 8 mA drive I/O, I <sub>OH</sub> = 8 mA	V <sub>DD</sub> - 0.4	—	—	
		5.0 V 12 mA drive I/O, I <sub>OH</sub> = 12 mA	V <sub>DD</sub> - 0.4	—	—	
		5.0 V 16 mA drive I/O, I <sub>OH</sub> = 16 mA	V <sub>DD</sub> - 0.4	—	—	
R <sub>PU</sub>	Internal Pull-up Resistor	5.0 V I/O, V <sub>DD</sub> = 5.0 V	—	60	—	kΩ
R <sub>PD</sub>	Internal Pull-down Resistor	5.0 V I/O, V <sub>DD</sub> = 5.0 V	—	60	—	kΩ

## ADC Characteristics

Table 18. ADC Characteristics

T<sub>A</sub> = 25 °C, unless otherwise specified.

Symbol	Parameter	Conditions	Min.	Typ.	Max.	Unit
V <sub>DDA</sub>	A/D Converter Operating Voltage	—	2.5	5.0	5.5	V
V <sub>ADCIN</sub>	A/D Converter Input Voltage Range	—	0	—	V <sub>REF+</sub>	V
V <sub>REF+</sub>	A/D Converter Reference Voltage	—	—	V <sub>DDA</sub>	V <sub>DDA</sub>	V
I <sub>ADC</sub>	Current Consumption	V <sub>DDA</sub> = 5.0 V	—	0.85	1	mA
I <sub>ADC_DN</sub>	Power Down Current Consumption	V <sub>DDA</sub> = 5.0 V	—	—	0.1	μA
f <sub>ADC</sub>	A/D Converter Clock Frequency	—	0.7	—	16	MHz
f <sub>S</sub>	Sampling Rate	—	0.05	—	1	MHz
t <sub>DL</sub>	Data Latency	—	—	12.5	—	1/f <sub>ADC</sub> Cycles
t <sub>S&amp;H</sub>	Sampling & Hold Time	—	—	3.5	—	1/f <sub>ADC</sub> Cycles
t <sub>ADCCONV</sub>	A/D Converter Conversion Time	—	—	16	—	1/f <sub>ADC</sub> Cycles
R <sub>I</sub>	Input Sampling Switch Resistance	—	—	—	1	kΩ
C <sub>I</sub>	Input Sampling Capacitance	No pin/pad capacitance included	—	16	—	pF
t <sub>SU</sub>	Startup Time	—	—	—	1	μs
N	Resolution	—	—	12	—	bits
INL	Integral Non-linearity Error	f <sub>S</sub> = 750 kHz, V <sub>DDA</sub> = 5.0 V	—	±2	±5	LSB
DNL	Differential Non-linearity Error	f <sub>S</sub> = 750 kHz, V <sub>DDA</sub> = 5.0 V	—	±1	—	LSB
E <sub>O</sub>	Offset Error	—	—	—	±10	LSB
E <sub>G</sub>	Gain Error	—	—	—	±10	LSB

Note: 1. Guaranteed by design, not tested in production.

2. The figure below shows the equivalent circuit of the A/D Converter Sample-and-Hold input stage where  $C_I$  is the storage capacitor,  $R_I$  is the resistance of the sampling switch and  $R_S$  is the output impedance of the signal source  $V_S$ . Normally the sampling phase duration is approximately,  $3.5/f_{ADC}$ . The capacitance,  $C_I$ , must be charged within this time frame and it must be ensured that the voltage at its terminals becomes sufficiently close to  $V_S$  for accuracy. To guarantee this,  $R_S$  is not allowed to have an arbitrarily large value.

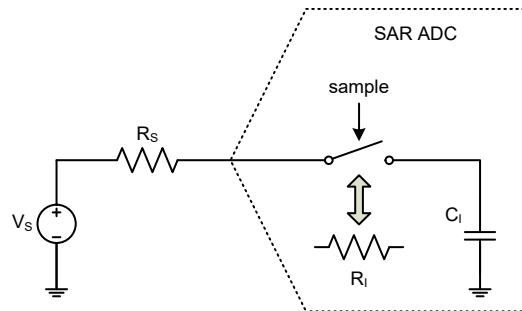

**Figure 5. ADC Sampling Network Model**

The worst case occurs when the extremities of the input range (0 V and  $V_{REF}$ ) are sampled consecutively. In this situation a sampling error below 1/4 LSB is ensured by using the following equation:

$$R_S < \frac{3.5}{f_{ADC} C_I \ln(2^{N+2})} - R_I$$

Where  $f_{ADC}$  is the ADC clock frequency and  $N$  is the ADC resolution ( $N = 12$  in this case). A safe margin should be considered due to the pin/pad parasitic capacitances, which are not accounted for in this simple model.

If, in a system where the A/D Converter is used, there are no rail-to-rail input voltage variations between consecutive sampling phases,  $R_S$  may be larger than the value indicated by the equation above.

## Comparator Characteristics

Table 19. Comparator Characteristics

T<sub>A</sub> = 25 °C, unless otherwise specified.

Symbol	Parameter	Conditions	Min	Typ	Max	Unit	
V <sub>DDA</sub>	Operating Voltage	Comparator mode	2.5	5.0	5.5	V	
V <sub>IN</sub>	Input Common Mode Voltage Range	CP or CN	V <sub>SSA</sub>	—	V <sub>DDA</sub>	V	
V <sub>IOS</sub>	Input Offset Voltage <sup>(1)</sup>	T <sub>A</sub> = 25 °C	-15	—	15	mV	
V <sub>HYS</sub>	Input Hysteresis V <sub>DDA</sub> = 5.0 V	No hysteresis, CMPHM [1:0] = 00	—	0	—	mV	
		Low hysteresis, CMPHM [1:0] = 01	—	50	—	mV	
		Middle hysteresis, CMPHM [1:0] = 10	—	100	—	mV	
		High hysteresis, CMPHM [1:0] = 11	—	150	—	mV	
t <sub>RT</sub>	Response Time Input Overdrive = ±100 mV	High Speed Mode	V <sub>DDA</sub> ≥ 3.6 V	—	50	100	ns
			V <sub>DDA</sub> < 3.6 V	—	100	250	
		Low Speed Mode		—	2	5	μs
I <sub>CMP</sub>	Current Consumption V <sub>DDA</sub> = 5.0 V	High Speed Mode		—	180	—	μA
		Low Speed Mode		—	50	—	μA
t <sub>CMPST</sub>	Comparator Startup Time	Comparator enabled to output valid	—	—	50	μs	
I <sub>CMP_DN</sub>	Power Down Supply Current	CMPEN = 0 CVREN = 0 CVROE = 0	—	—	0.1	μA	

### Comparator Voltage Reference (CVR)

V <sub>CVR</sub>	Output Range	—	V <sub>SSA</sub>	—	V <sub>DDA</sub>	V
N <sub>Bits</sub>	CVR Scaler Resolution	—	—	6	—	bits
t <sub>CVRST</sub>	Settling Time	CVR Scaler Setting Time from CVRVAL[5:0] = “000000” to “111111”	—	—	100	μs
I <sub>CVR</sub>	Current Consumption V <sub>DDA</sub> = 5.0 V	CVREN = 1, CVROE = 0	—	100	—	μA
		CVREN = 1, CVROE = 1	—	125	150	μA

Note: Guaranteed by design, not tested in production.

## Operational Amplifier Characteristics

**Table 20. Operational Amplifier Characteristics**

Symbol	Parameter	Conditions	Min.	Typ.	Max.	Unit
V <sub>DDA</sub>	Operating Voltage	OPA mode	2.5	5.0	5.5	V
I <sub>OPA_DN</sub>	Power Down Current	—	—	—	0.1	μA
V <sub>OPOS</sub>	Input Offset Voltage	Without calibration	-15	—	15	mV
V <sub>CM</sub>	Common Mode Voltage Range	—	V <sub>SS</sub> +0.2	—	V <sub>DD</sub> -0.2	V
V <sub>OR</sub>	Maximum output voltage range	—	V <sub>SS</sub> +0.2	—	V <sub>DD</sub> -0.2	V
I <sub>DD</sub>	Current Dissipation	—	—	800	—	μA
PSRR	Power Supply Rejection Ratio	—	—	80	—	dB
CMRR	Common Mode Rejection Ratio	V <sub>CM</sub> = 0 ~ V <sub>DD</sub>	—	80	—	dB
SR	Slew Rate+, Slew Rate-	R <sub>L</sub> = 100 kΩ, C <sub>L</sub> = 100 pF	6	—	—	V/μs
GBW	Gain Band Width	R <sub>L</sub> = 100 kΩ, C <sub>L</sub> = 100 pF	—	6	—	MHz
A <sub>OL</sub>	Open Loop Gain	R <sub>L</sub> = 100 kΩ, C <sub>L</sub> = 100 pF	60	80	—	dB
PM	Phase Margin	R <sub>L</sub> = 100 kΩ, C <sub>L</sub> = 100 pF	50	60	—	

## MCTM/GPTM/SCTM Characteristics

**Table 21. MCTM/GPTM/SCTM Characteristics**

Symbol	Parameter	Conditions	Min.	Typ.	Max.	Unit
f <sub>TM</sub>	Timer Clock Source for MCTM, GPTM and SCTM	—	—	—	f <sub>PCLK</sub>	MHz
t <sub>RES</sub>	Timer Resolution Time	—	1	—	—	1/f <sub>TM</sub>
f <sub>EXT</sub>	External Signal Frequency on Channel 0 ~ 3	—	—	—	1/2	f <sub>TM</sub>
RES	Timer Resolution	—	—	—	16	bits

## I<sup>2</sup>C Characteristics

**Table 22. I<sup>2</sup>C Characteristics**

Symbol	Parameter	Standard Mode		Fast Mode		Fast Plus Mode		Unit
		Min.	Max.	Min.	Max.	Min.	Max.	
f <sub>SCL</sub>	SCL Clock Frequency	—	100	—	400	—	1000	kHz
t <sub>SCL(H)</sub>	SCL Clock High Time	4.5	—	1.125	—	0.45	—	μs
t <sub>SCL(L)</sub>	SCL Clock Low Time	4.5	—	1.125	—	0.45	—	μs
t <sub>FALL</sub>	SCL and SDA Fall Time	—	1.3	—	0.34	—	0.135	μs
t <sub>RISE</sub>	SCL and SDA Rise Time	—	1.3	—	0.34	—	0.135	μs
t <sub>SU(SDA)</sub>	SDA Data Setup Time	500	—	125	—	50	—	ns

Symbol	Parameter	Standard Mode		Fast Mode		Fast Plus Mode		Unit
		Min.	Max.	Min.	Max.	Min.	Max.	
$t_{H(SDA)}$	SDA Data Hold Time	0	—	0	—	0	—	ns
$t_{SU(STA)}$	START Condition Setup Time	500	—	125	—	50	—	ns
$t_{H(STA)}$	START Condition Hold Time	0	—	0	—	0	—	ns
$t_{SU(STO)}$	STOP Condition Setup Time	500	—	125	—	50	—	ns

- Note: 1. Guaranteed by design, not tested in production.  
 2. To achieve 100 kHz standard mode, the peripheral clock frequency must be higher than 2 MHz.  
 3. To achieve 400 kHz fast mode, the peripheral clock frequency must be higher than 8 MHz.  
 4. To achieve 1 MHz fast mode plus, the peripheral clock frequency must be higher than 20 MHz.  
 5. The above characteristic parameters of the I<sup>2</sup>C bus timing are based on: SEQFILTER = 01 and COMBFILTEREN = 0 that COMB\_filter is disabled.

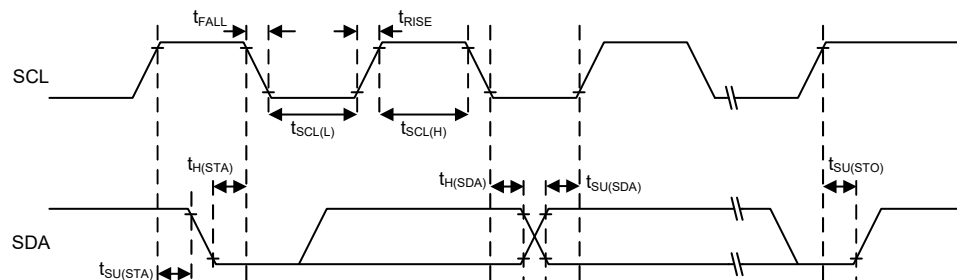

Figure 6. I<sup>2</sup>C Timing Diagram

## SPI Characteristics

Table 23. SPI Characteristics

Symbol	Parameter	Conditions	Min.	Typ.	Max.	Unit
<b>SPI Master Mode</b>						
$f_{SCK}$	SPI Master Output SCK Clock Frequency	Master mode SPI peripheral clock frequency $f_{PCLK}$	—	—	$f_{PCLK}/2$	MHz
$t_{SCK(H)}$ $t_{SCK(L)}$	SCK Clock High and Low Time	—	$t_{SCK}/2 - 2$	—	$t_{SCK}/2 + 1$	ns
$t_{V(MO)}$	Data Output Valid Time	—	—	—	5	ns
$t_{H(MO)}$	Data Output Hold Time	—	2	—	—	ns
$t_{SU(MI)}$	Data Input Setup Time	—	5	—	—	ns
$t_{H(MI)}$	Data Input Hold Time	—	5	—	—	ns

Symbol	Parameter	Conditions	Min.	Typ.	Max.	Unit
<b>SPI Slave Mode</b>						
$f_{SCK}$	SPI Slave Input SCK Clock Frequency	Slave mode SPI peripheral clock frequency $f_{PCLK}$	—	—	$f_{PCLK}/3$	MHz
$Duty_{SCK}$	SPI Slave Input SCK Clock Duty Cycle	—	30	—	70	%
$t_{SU(SEL)}$	SEL Enable Setup Time	—	$3 t_{PCLK}$	—	—	ns
$t_{H(SEL)}$	SEL Enable Hold Time	—	$2 t_{PCLK}$	—	—	ns
$t_{A(SO)}$	Data Output Access Time	—	—	—	$3 t_{PCLK}$	ns
$t_{DIS(SO)}$	Data Output Disable Time	—	—	—	10	ns
$t_{V(SO)}$	Data Output Valid Time	—	—	—	25	ns
$t_{H(SO)}$	Data Output Hold Time	—	15	—	—	ns
$t_{SU(SI)}$	Data Input Setup Time	—	5	—	—	ns
$t_{H(SI)}$	Data Input Hold Time	—	4	—	—	ns

Note: 1.  $f_{SCK}$  is SPI output/input clock frequency and  $t_{SCK} = 1/f_{SCK}$ .  
2.  $f_{PCLK}$  is SPI peripheral clock frequency and  $t_{PCLK} = 1/f_{PCLK}$ .

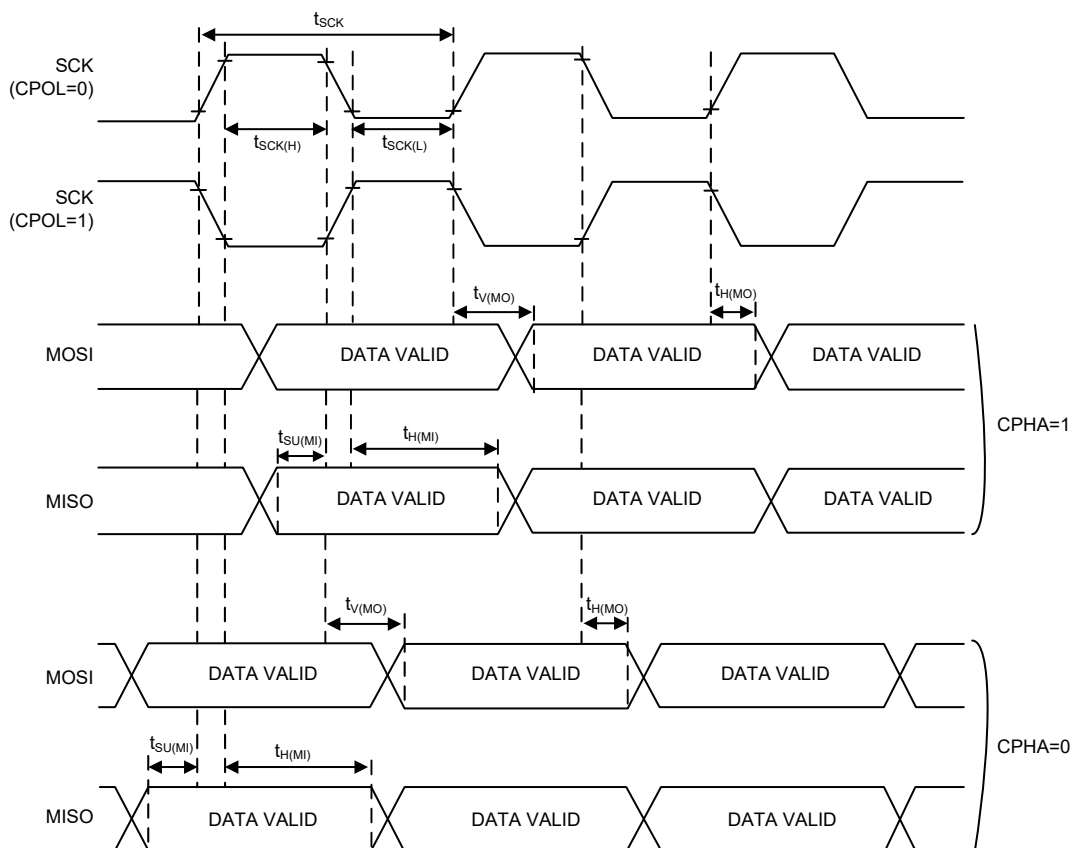
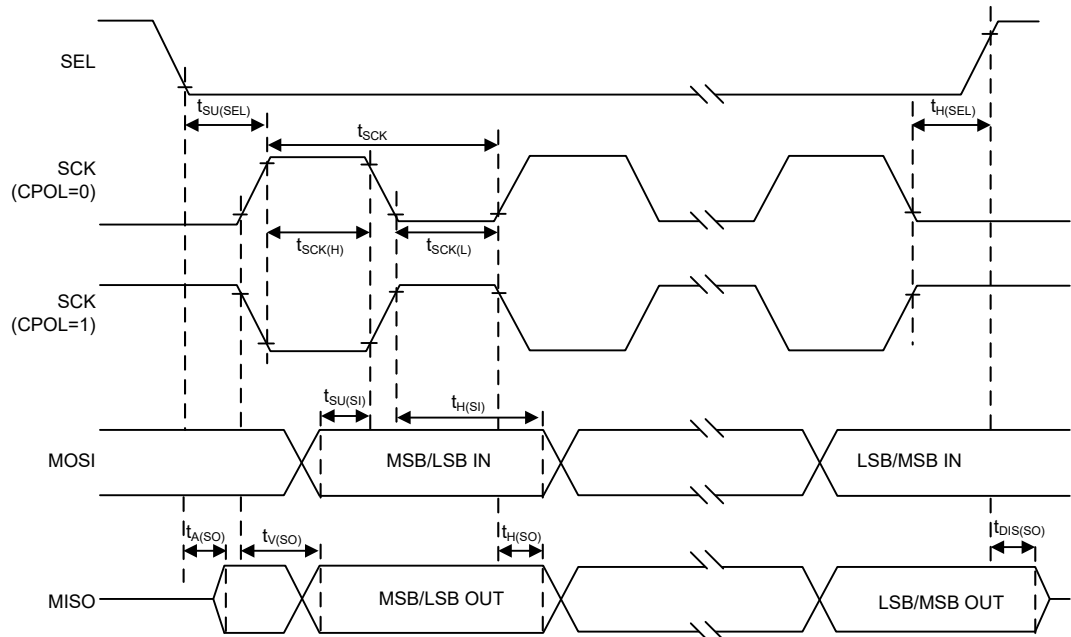

Figure 7. SPI Timing Diagram – SPI Master Mode



**Figure 8. SPI Timing Diagram – SPI Slave Mode with CPHA = 1**

# 7 Package Information

---

Note that the package information provided here is for consultation purposes only. As this information may be updated at regular intervals users are reminded to consult the [Holtek website](#) for the latest version of the [Package/Carton Information](#).

Additional supplementary information with regard to packaging is listed below. Click on the relevant section to be transferred to the relevant website page.

- Package Information (include Outline Dimensions, Product Tape and Reel Specifications)
- The Operation Instruction of Packing Materials
- Carton information



## 48-pin LQFP (7mm×7mm) Outline Dimensions

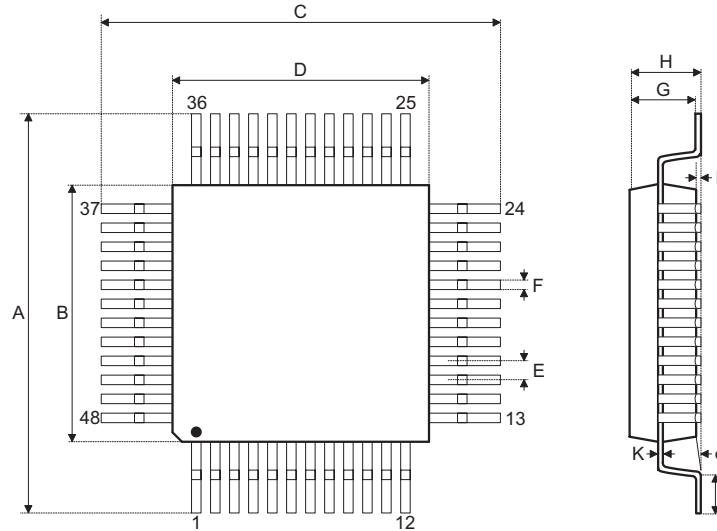

Symbol	Dimensions in inch		
	Min.	Nom.	Max.
A	—	0.354 BSC	—
B	—	0.276 BSC	—
C	—	0.354 BSC	—
D	—	0.276 BSC	—
E	—	0.020 BSC	—
F	0.007	0.009	0.011
G	0.053	0.055	0.057
H	—	—	0.063
I	0.002	—	0.006
J	0.018	0.024	0.030
K	0.004	—	0.008
$\alpha$	0°	—	7°

Symbol	Dimensions in mm		
	Min.	Nom.	Max.
A	—	9.0 BSC	—
B	—	7.0 BSC	—
C	—	9.0 BSC	—
D	—	7.0 BSC	—
E	—	0.5 BSC	—
F	0.17	0.22	0.27
G	1.35	1.4	1.45
H	—	—	1.60
I	0.05	—	0.15
J	0.45	0.60	0.75
K	0.09	—	0.20
$\alpha$	0°	—	7°

Copyright© 2022 by HOLTEK SEMICONDUCTOR INC.

The information appearing in this Data Sheet is believed to be accurate at the time of publication. However, Holtek assumes no responsibility arising from the use of the specifications described. The applications mentioned herein are used solely for the purpose of illustration and Holtek makes no warranty or representation that such applications will be suitable without further modification, nor recommends the use of its products for application that may present a risk to human life due to malfunction or otherwise. Holtek's products are not authorized for use as critical components in life support devices or systems. Holtek reserves the right to alter its products without prior notification. For the most up-to-date information, please visit our web site at <http://www.holtek.com>.