



HT32F50231/HT32F50241 Datasheet

**32-Bit Arm® Cortex®-M0+ 5V Microcontroller,
up to 64 KB Flash and 8 KB SRAM with 1 Msps ADC,
DIV, USART, UART, SPI, I²C, MCTM, GPTM,
BFTM, PWM, CRC, RTC and WDT**

Revision: V1.41 Date: May 14, 2024

www.holtek.com

Table of Contents

1 General Description	6
2 Development Tools	7
3 Features	7
Core	7
On-chip Memory	7
Flash Memory Controller – FMC	7
Reset Control Unit – RSTCU	8
Clock Control Unit – CKCU	8
Power Management Control Unit – PWRCU	8
Real Time Clock – RTC	8
External Interrupt/Event Controller – EXTI	9
Hardware Divider – DIV	9
Analog to Digital Converter – ADC	9
I/O Ports – GPIO	9
Basic Function Timer – BFTM	10
Motor Control Timer – MCTM	10
General-Purpose Timer – GPTM	10
Pulse-Width-Modulation Timer – PWM	11
Watchdog Timer – WDT	11
Inter-integrated Circuit – I ² C	11
Serial Peripheral Interface– SPI	12
Universal Synchronous Asynchronous Receiver Transmitter – USART	12
Universal Asynchronous Receiver Transmitter – UART	12
Cyclic Redundancy Check – CRC	13
Debug Support	13
Package and Operation Temperature	13
4 Overview	14
Device Information	14
Block Diagram	15
Memory Map	16
Clock Structure	19
5 Pin Assignment	20
6 Electrical Characteristics	31
Absolute Maximum Ratings	31
Recommended DC Operating Conditions	31

On-Chip LDO Voltage Regulator Characteristics.....	31
Power Consumption	32
Reset and Supply Monitor Characteristics.....	33
External Clock Characteristics	34
Internal Clock Characteristics	35
Memory Characteristics	35
I/O Port Characteristics.....	35
ADC Characteristics	37
MCTM/GPTM/PWM Characteristics	38
I ² C Characteristics	38
SPI Characteristics	39
7 Package Information	41
24-pin SSOP (150mil) Outline Dimensions.....	42
28-pin SSOP (150mil) Outline Dimensions.....	43
28-pin SOP (300mil) Outline Dimensions	44
SAW Type 24-pin QFN (3mm×3mm×0.55mm) Outline Dimensions.....	45
SAW Type 33-pin QFN (4mm×4mm×0.75mm) Outline Dimensions	46
SAW Type 46-pin QFN (6.5mm×4.5mm×0.75mm) Outline Dimensions.....	47
44-pin LQFP (10mm×10mm) (FP2.0mm) Outline Dimensions	48
48-pin LQFP (7mm×7mm) Outline Dimensions.....	49

List of Tables

Table 1. Features and Peripheral List	14
Table 2. Register Map	17
Table 3. Pin Assignment	28
Table 4. Pin Description	29
Table 5. Absolute Maximum Ratings.....	31
Table 6. Recommended DC Operating Conditions.....	31
Table 7. LDO Characteristics	31
Table 8. Power Consumption Characteristics	32
Table 9. V _{DD} Power Reset Characteristics	33
Table 10. LVD/BOD Characteristics.....	33
Table 11. High Speed External Clock (HSE) Characteristics	34
Table 12. Low Speed External Clock (LSE) Characteristics	34
Table 13. High Speed Internal Clock (HSI) Characteristics	35
Table 14. Low Speed Internal Clock (LSI) Characteristics.....	35
Table 15. Flash Memory Characteristics.....	35
Table 16. I/O Port Characteristics	35
Table 17. ADC Characteristics	37
Table 18. MCTM/GPTM/PWM Characteristics	38
Table 19. I ² C Characteristics.....	38
Table 20. SPI Characteristics.....	39

List of Figures

Figure 1. Block Diagram	15
Figure 2. Memory Map.....	16
Figure 3. Clock Structure	19
Figure 4. 24-pin SSOP Pin Assignment.....	20
Figure 5. 28-pin SSOP Pin Assignment.....	21
Figure 6. 28-pin SOP Pin Assignment	22
Figure 7. 24-pin QFN Pin Assignment	23
Figure 8. 33-pin QFN Pin Assignment	24
Figure 9. 46-pin QFN Pin Assignment	25
Figure 10. 44-pin LQFP Pin Assignment.....	26
Figure 11. 48-pin LQFP Pin Assignment.....	27
Figure 12. ADC Sampling Network Model	37
Figure 13. I ² C Timing Diagrams.....	39
Figure 14. SPI Timing Diagrams – SPI Master Mode	40
Figure 15. SPI Timing Diagrams – SPI Slave Mode with CPHA=1.....	40

1 General Description

The Holtek HT32F50231/50241 devices are high performance, low power consumption 32-bit microcontrollers based around an Arm® Cortex®-M0+ processor core. The Cortex®-M0+ is a next-generation processor core which is tightly coupled with Nested Vectored Interrupt Controller (NVIC), SysTick timer, and including advanced debug support.

The devices operate at a frequency of up to 20 MHz with a Flash accelerator to obtain maximum efficiency. It provides up to 64 KB of embedded Flash memory for code/data storage and 8 KB of embedded SRAM memory for system operation and application program usage. A variety of peripherals, such as Hardware Divider DIV, ADC, I²C, USART, UART, SPI, MCTM, GPTM, PWM, BFTM, CRC-16/32, RTC, WDT, SW-DP (Serial Wire Debug Port), etc., are also implemented in the devices. Several power saving modes provide the flexibility for maximum optimization between wakeup latency and power consumption, an especially important consideration in low power applications.

The above features ensure that the devices are suitable for use in a wide range of applications, especially in areas such as white goods application controllers, power monitors, alarm systems, consumer products, handheld equipment, data logging applications, motor controllers and so on.

arm CORTEX

2 Development Tools

For rapid product development and to simplify device parameter setting, Holtek has provided relevant development tools which users can download from the following link:

https://www.holtek.com/page/detail/dev_plat/DALI_Workshop

3 Features

Core

- 32-bit Arm® Cortex®-M0+ processor core
- Up to 20 MHz operating frequency
- Single-cycle multiplication
- Integrated Nested Vectored Interrupt Controller (NVIC)
- 24-bit SysTick timer

The Cortex®-M0+ processor is a very low gate count, highly energy efficient processor that is intended for microcontroller and deeply embedded applications that require an area optimized, low-power processor. The processor is based on the ARMv6-M architecture and supports Thumb® instruction sets, single-cycle I/O ports, hardware multiplier and low latency interrupt respond time.

On-chip Memory

- Up to 64 KB on-chip Flash memory for instruction/data and option bytes storage
- Up to 8 KB on-chip SRAM
- Supports multiple boot modes

The Arm® Cortex®-M0+ processor accesses and debug accesses share the single external interface to external AHB peripherals. The processor access takes priority over debug access. The maximum address range of the Cortex®-M0+ is 4 GB since it has a 32-bit bus address width. Additionally, a pre-defined memory map is provided by the Cortex®-M0+ processor to reduce the software complexity of repeated implementation by different device vendors. However, some regions are used by the Arm® Cortex®-M0+ system peripherals. Refer to the Arm® Cortex®-M0+ Technical Reference Manual for more information. Figure 2 in the Overview chapter shows the memory map of the HT32F50231/50241 series devices, including code, SRAM, peripheral and other pre-defined regions.

Flash Memory Controller – FMC

- 32-bit word programming with In System Programming (ISP) and In Application Programming (IAP)
- Flash protection capability to prevent illegal access

The Flash Memory Controller, FMC, provides all the necessary functions for the embedded on-chip Flash Memory. The word program/page erase functions are also provided.

Reset Control Unit – RSTCU

- Supply supervisor:
 - Power on Reset / Power down Reset – POR / PDR
 - Brown-out Detector – BOD
 - Programmable Low Voltage Detector – LVD

The Reset Control Unit, RSTCU, has three kinds of reset, a power on reset, a system reset and an APB unit reset. The power on reset, known as a cold reset, resets the full system during power up. A system reset resets the processor core and peripheral IP components with the exception of the SW-DP controller. The resets can be triggered by external signals, internal events and the reset generators.

Clock Control Unit – CKCU

- External 4 to 20 MHz crystal oscillator
- External 32.768 kHz crystal oscillator
- Internal 20 MHz RC oscillator trimmed to $\pm 2\%$ accuracy at 25 °C operating temperature
- Internal 32 kHz RC oscillator
- Independent clock divider and gating bits for peripheral clock sources

The Clock Control Unit, CKCU, provides a range of oscillator and clock functions. These include a High Speed Internal RC oscillator (HSI), a High Speed External crystal oscillator (HSE), a Low Speed Internal RC oscillator (LSI), a Low Speed External crystal oscillator (LSE), an HSE clock monitor, clock pre-scalers, clock multiplexers, APB clock divider and gating circuitry. The AHB, APB and Cortex®-M0+ clocks are derived from the system clock (CK_SYS) which can come from the HSI, HSE, LSI or LSE. The Watchdog Timer and Real Time Clock (RTC) use either the LSI or LSE as their clock source.

Power Management Control Unit – PWRCU

- Flexible power supply: V_{DD} power supply (2.5 V ~ 5.5 V), V_{DDIO} for I/Os (1.8 V ~ 5.5 V)
- Integrated 1.5 V LDO regulator for MCU core, peripherals and memories power supply
- V_{DD} , V_{DDIO} and V_{CORE} power domains
- Three power saving modes: Sleep, Deep-Sleep1, Deep-Sleep2

Power consumption can be regarded as one of the most important issues for many embedded system applications. Accordingly the Power Control Unit, PWRCU, in these devices provides many types of power saving modes such as Sleep, Deep-Sleep1 and Deep-Sleep2 mode. These operating modes reduce the power consumption and allow the application to achieve the best trade-off between the conflicting demands of CPU operating time, speed and power consumption.

Real Time Clock – RTC

- 24-bit up-counter with a programmable prescaler
- Alarm function
- Interrupt and Wake-up event

The Real Time Clock, RTC, includes an APB interface, a 24-bit count-up counter, a control register, a prescaler, a compare register and a status register. The RTC circuits are located in the V_{CORE} power domain. When the device enters the power-saving mode, the RTC counter is used as a wakeup timer to let the system resume from the power saving mode.

External Interrupt/Event Controller – EXTI

- Up to 16 EXTI lines with configurable trigger source and type
- All GPIO pins can be selected as EXTI trigger source
- Source trigger type includes high level, low level, negative edge, positive edge or both edges
- Individual interrupt enable, wakeup enable and status bits for each EXTI line
- Software interrupt trigger mode for each EXTI line
- Integrated deglitch filter for short pulse blocking

The External Interrupt/Event Controller, EXTI, comprises 16 edge detectors which can generate a wake-up event or interrupt requests independently. Each EXTI line can also be masked independently.

Hardware Divider – DIV

- Signed/unsigned 32-bit divider
- Operation in 8 clock cycles, load in 1 clock cycle
- Divide by zero error Flag

The divider is the truncated division and needs a software triggered start signal by using the control register “START” bit. After 8 clock cycles, the divider calculate complete flag will be set to 1, and if the divisor register data is zero, the divide by zero error flag will be set to 1.

Analog to Digital Converter – ADC

- 12-bit SAR ADC engine
- Up to 1 Msps conversion rate
- Up to 12 external analog input channels

A 12-bit multi-channel Analog to Digital Converter is integrated in these devices. There are multiplexed channels, which include 12 external analog signal channels and 2 internal channels which can be measured. If the input voltage is required to remain within a specific threshold window, an Analog Watchdog function will monitor and detect these signals. An interrupt will then be generated to inform the device that the input voltage is not within the preset thresholds. There are three conversion modes to convert an analog signal to digital data. The ADC can be operated in one shot, continuous and discontinuous conversion modes.

I/O Ports – GPIO

- Up to 40 GPIOs
- Port A, B, C are mapped as 16 external interrupts – EXTI
- Almost all I/O pins have configurable output driving current

There are up to 40 General Purpose I/O pins, GPIO, for the implementation of logic input/output functions. Each of the GPIO ports has a series of related control and configuration registers to maximize flexibility and to meet the requirements of a wide range of applications.

The GPIO ports are pin-shared with other alternative functions to obtain maximum functional flexibility on the package pins. The GPIO pins can be used as alternative functional pins by configuring the corresponding registers regardless of the input or output pins. The external interrupts on the GPIO pins of the device have related control and configuration registers in the External Interrupt Control Unit, EXTI.

Basic Function Timer – BFTM

- 32-bit compare match count-up counter – no I/O control
- One shot mode – counter stops counting when compare match occurs
- Repetitive mode – counter restarts when compare match occurs

The Basic Function Timer Module, BFTM, is a simple 32-bit up-counting counter designed to measure time intervals and generate a one shot or repetitive interrupts. The BFTM can operate in two modes, repetitive and one shot modes. In the repetitive mode, the counter will restart at each compare match event. The BFTM also supports a one shot mode which will force the counter to stop counting when a compare match event occurs.

Motor Control Timer – MCTM

- 16-bit up, down, up/down auto-reload counter
- Up to 4 independent channels
- 16-bit programmable prescaler that allows division of the prescaler clock source by any factor between 1 and 65536 to generate the counter clock frequency
- Input Capture function
- Compare Match Output
- PWM waveform generation with Edge-aligned and Center-aligned Counting
- Single Pulse Mode Output
- Complementary Outputs with programmable dead-time insertion
- Break input to force the timer's output signals into a reset or fixed condition

The Motor Control Timer Module, MCTM, consists of one 16-bit up/down-counter, four 16-bit Capture/Compare Registers (CCRs), one 16-bit Counter Reload Register (CRR), one 8-bit repetition counter and several control/status registers. It can be used for a variety of purposes including measuring the pulse width of input signals or generating output waveforms such as compare match outputs, PWM outputs or complementary PWM outputs with dead-time insertion. The MCTM is capable of offering full functional support for motor control, hall sensor interfacing and break input.

General-Purpose Timer – GPTM

- 16-bit up, down, up/down auto-reload counter
- Up to 4 independent channels
- 16-bit programmable prescaler that allows division of the prescaler clock source by any factor between 1 and 65536 to generate the counter clock frequency
- Input Capture function
- Compare Match Output
- PWM waveform generation with Edge-aligned and Center-aligned Counting
- Single Pulse Mode Output
- Encoder interface controller with two inputs using quadrature decoder

The General Purpose Timer Module, GPTM, consists of one 16-bit up/down-counter, four 16-bit Capture / Compare Registers (CCRs), one 16-bit Counter Reload Register (CRR) and several control / status registers. It can be used for a variety of purposes including general time measurement, input signal pulse width measurement, output waveform generation such as single pulse generation or PWM output generation. The GPTM supports an Encoder Interface using a quadrature decoder with two inputs.

Pulse-Width-Modulation Timer – PWM

- 16-bit up, down, up/down auto-reload counter
- Up to 4 independent channels for each timer
- 16-bit programmable prescaler that allows division of the prescaler clock source by any factor between 1 and 65536 to generate the counter clock frequency
- Compare Match Output
- PWM waveform generation with Edge-aligned and Center-aligned Counting
- Single Pulse Mode Output

The Pulse-Width-Modulation Timer, PWM, consists of one 16-bit up/down-counter, four 16-bit Compare Registers (CRs), one 16-bit Counter-Reload Register (CRR) and several control/status registers. It can be used for a variety of purposes including general timer and output waveform generation such as single pulse generation or PWM output.

Watchdog Timer – WDT

- 12-bit down counter with 3-bit prescaler
- Provides reset to the system
- Programmable watchdog timer window function
- Register write protection function

The Watchdog Timer is a hardware timing circuit that can be used to detect a system lock-up due to software trapped in a deadlock. It includes a 12-bit count-down counter, a prescaler, a WDT delta value register, WDT operation control circuitry and a WDT protection mechanism. If the software does not reload the counter value before a Watchdog Timer underflow occurs, a reset will be generated when the counter underflows. In addition, a reset is also generated if the software reloads the counter when it reaches a delta value. This means the counter must be reloaded within a limited timing window using a specific method. The Watchdog Timer counter can be stopped while the processor is in the debug mode. The register write protect function which can be enabled to prevent an unexpected change in the Watchdog timer configuration.

Inter-integrated Circuit – I²C

- Supports both master and slave modes with a frequency of up to 1 MHz
- Provides an arbitration function and clock synchronization
- Supports 7-bit and 10-bit addressing modes and general call addressing
- Supports slave multi-addressing mode with address mask function

The I²C is an internal circuit allowing communication with an external I²C interface which is an industry standard two line serial interface used for connection to external hardware. These two serial lines are known as a serial data line, SDA, and a serial clock line, SCL. The I²C module provides three data transfer rates: 100 kHz in the Standard mode, 400 kHz in the Fast mode and 1 MHz in the Fast plus mode. The SCL period generation register is used to setup different kinds of duty cycle implementations for the SCL pulse.

The SDA line which is connected directly to the I²C bus is a bi-directional data line between the master and slave devices and is used for data transmission and reception. The I²C also has an arbitration detect function and clock synchronization to prevent situations where more than one master attempts to transmit data to the I²C bus at the same time.

Serial Peripheral Interface– SPI

- Supports both master and slave modes
- Frequency of up to ($f_{PCLK}/2$) MHz for the master mode and ($f_{PCLK}/3$) MHz for the slave mode
- FIFO Depth: 8 levels
- Multi-master and multi-slave operation

The Serial Peripheral Interface, SPI, provides a SPI protocol data transmit and receive function in both master and slave modes. The SPI interface uses 4 pins, which are the serial data input and output lines MISO and MOSI, the clock line, SCK, and the slave select line, SEL. One SPI device acts as a master device which controls the data flow using the SEL and SCK signals to indicate the start of data communication and the data sampling rate. To receive a data byte, the streamed data bits are latched on a specific clock edge and stored in the data register or in the RX FIFO. Data transmission is carried out in a similar way but in a reverse sequence. The mode fault detection provides a capability for multi-master applications.

Universal Synchronous Asynchronous Receiver Transmitter – USART

- Supports both asynchronous and clocked synchronous serial communication modes
- Programmable baud rate clock frequency up to ($f_{PCLK}/16$) MHz for Asynchronous mode and ($f_{PCLK}/8$) MHz for synchronous mode
- Full duplex communication
- Fully programmable serial communication characteristics including:
 - Word length: 7, 8 or 9-bit character
 - Parity: Even, odd or no-parity bit generation and detection
 - Stop bit: 1 or 2 stop bits generation
 - Bit order: LSB-first or MSB-first transfer
- Error detection: Parity, overrun and frame error
- Auto hardware flow control mode – RTS, CTS
- IrDA SIR encoder and decoder
- RS485 mode with output enable control
- FIFO Depth: 8-level for both receiver and transmitter

The Universal Synchronous Asynchronous Receiver Transceiver, USART, provides a flexible full duplex data exchange using synchronous or asynchronous transfer. The USART is used to translate data between parallel and serial interfaces, and is commonly used for RS232 standard communication. The USART peripheral function supports four types of interrupt including Line Status Interrupt, Transmitter FIFO Empty Interrupt, Receiver Threshold Level Reaching Interrupt and Time Out Interrupt. The USART module includes a transmitter FIFO (TX_FIFO) and receiver FIFO (RX_FIFO). The software can detect a USART error status by reading the USART Status & Interrupt Flag Register, USRSIFR. The status includes the type and the condition of transfer operations as well as several error conditions resulting from Parity, Overrun, Framing and Break events.

Universal Asynchronous Receiver Transmitter – UART

- Asynchronous serial communication operating baud-rate clock frequency up to ($f_{PCLK}/16$) MHz
- Full duplex communication
- Fully programmable serial communication characteristics including:
 - Word length: 7, 8 or 9-bit character
 - Parity: Even, odd or no-parity bit generation and detection
 - Stop bit: 1 or 2 stop bits generation
 - Bit order: LSB-first or MSB-first transfer

- Error detection: Parity, overrun and frame error

The Universal Asynchronous Receiver Transceiver, UART, provides a flexible full duplex data exchange using asynchronous transfer. The UART is used to translate data between parallel and serial interfaces, and is commonly used for RS232 standard communication. The UART peripheral function supports Line Status Interrupt. The software can detect a UART error status by reading the UART Status & Interrupt Flag Register, URSIFR. The status includes the type and the condition of transfer operations as well as several error conditions resulting from Parity, Overrun, Framing and Break events.

Cyclic Redundancy Check – CRC

- Supports CRC16 polynomial: 0x8005,
 $X^{16}+X^{15}+X^2+1$
- Supports CCITT CRC16 polynomial: 0x1021,
 $X^{16}+X^{12}+X^5+1$
- Supports IEEE-802.3 CRC32 polynomial: 0x04C11DB7,
 $X^{32}+X^{26}+X^{23}+X^{22}+X^{16}+X^{12}+X^{11}+X^{10}+X^8+X^7+X^5+X^4+X^2+X+1$
- Supports 1's complement, byte reverse & bit reverse operation on data and checksum
- Supports byte, half-word & word data size
- Programmable CRC initial seed value
- CRC computation executed in 1 AHB clock cycle for 8-bit data and 4 AHB clock cycles for 32-bit data

The CRC calculation unit is an error detection technique test algorithm which is used to verify data transmission or storage data correctness. A CRC calculation takes a data stream or a block of data as its input and generates a 16-bit or 32-bit output remainder. Ordinarily, a data stream is suffixed by a CRC code and used as a checksum when being sent or stored. Therefore, the received or restored data stream is calculated by the same generator polynomial as described above. If the new CRC code result does not match the one calculated earlier, that means the data stream contains a data error.

Debug Support

- Serial Wire Debug Port – SW-DP
- 4 comparators for hardware breakpoint or code / literal patch
- 2 comparators for hardware watch points

Package and Operation Temperature

- 24/28-pin SSOP, 28-pin SOP, 24/33/46-pin QFN and 44/48-pin LQFP packages
- Operation temperature range: -40 °C to 85 °C

4 Overview

Device Information

Table 1. Features and Peripheral List

Peripherals		HT32F50231	HT32F50241
Main Flash (KB)		32	63
Option Bytes Flash (KB)		1	1
SRAM (KB)		4	8
Timers	MCTM		1
	GPTM		1
	PWM		2
	BFTM		2
	WDT		1
	RTC		1
Communication	SPI		2
	USART		1
	UART		2
	I ² C		2
Hardware Divider			1
CRC-16/32			1
EXTI			16
12-bit ADC			1
Number of channels			12 Channels
GPIO			Up to 40
CPU frequency			Up to 20 MHz
Operating voltage			2.5 V ~ 5.5 V
Operating temperature			-40 °C ~ 85 °C
Package		24/28-pin SSOP, 28-pin SOP 24/33/46-pin QFN and 44/48-pin LQFP	

Block Diagram

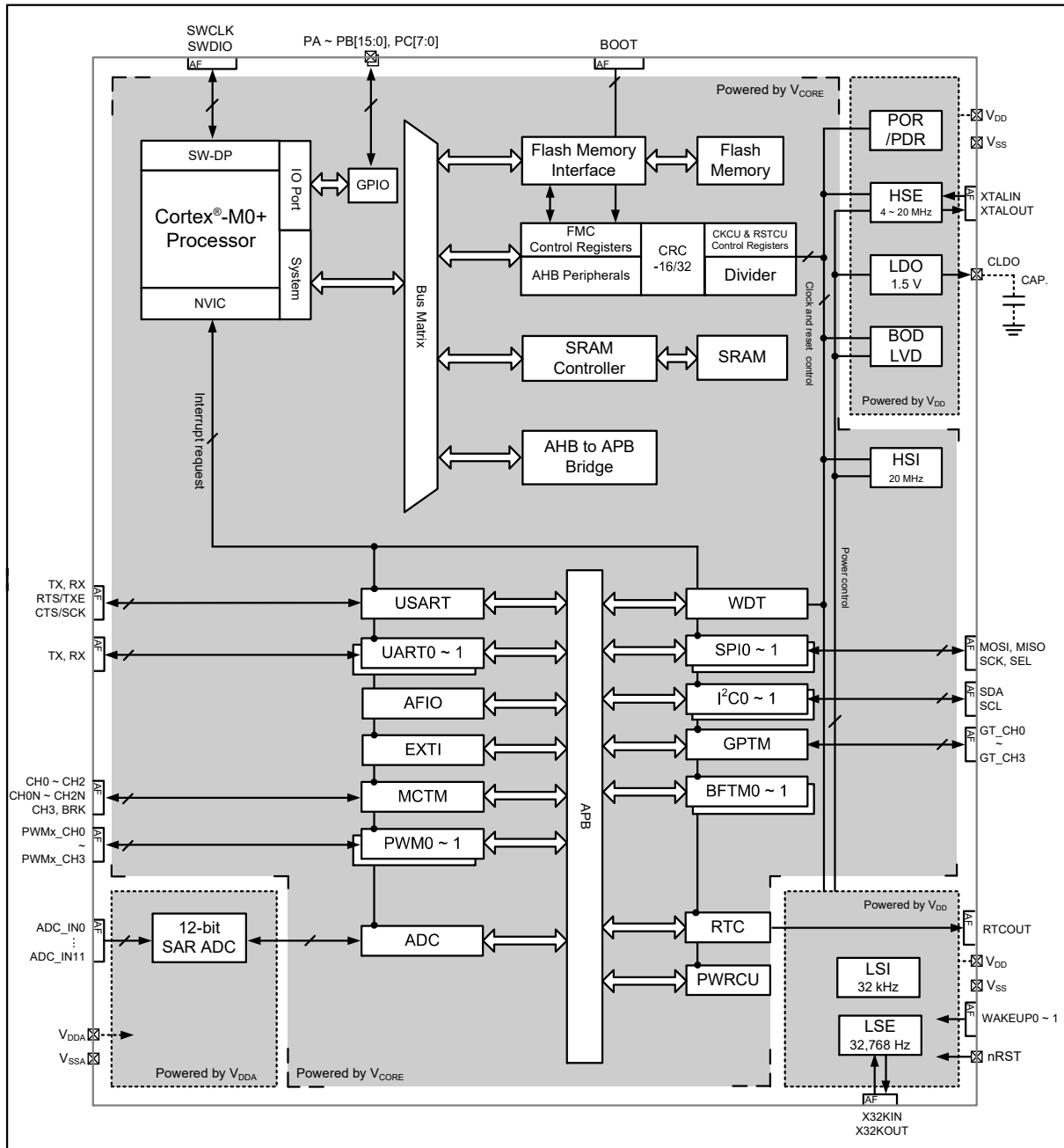

Power supply:
 Bus: \rightleftarrows
 Control signal: \longleftrightarrow
 Alternate function: AFE

Figure 1. Block Diagram

Memory Map

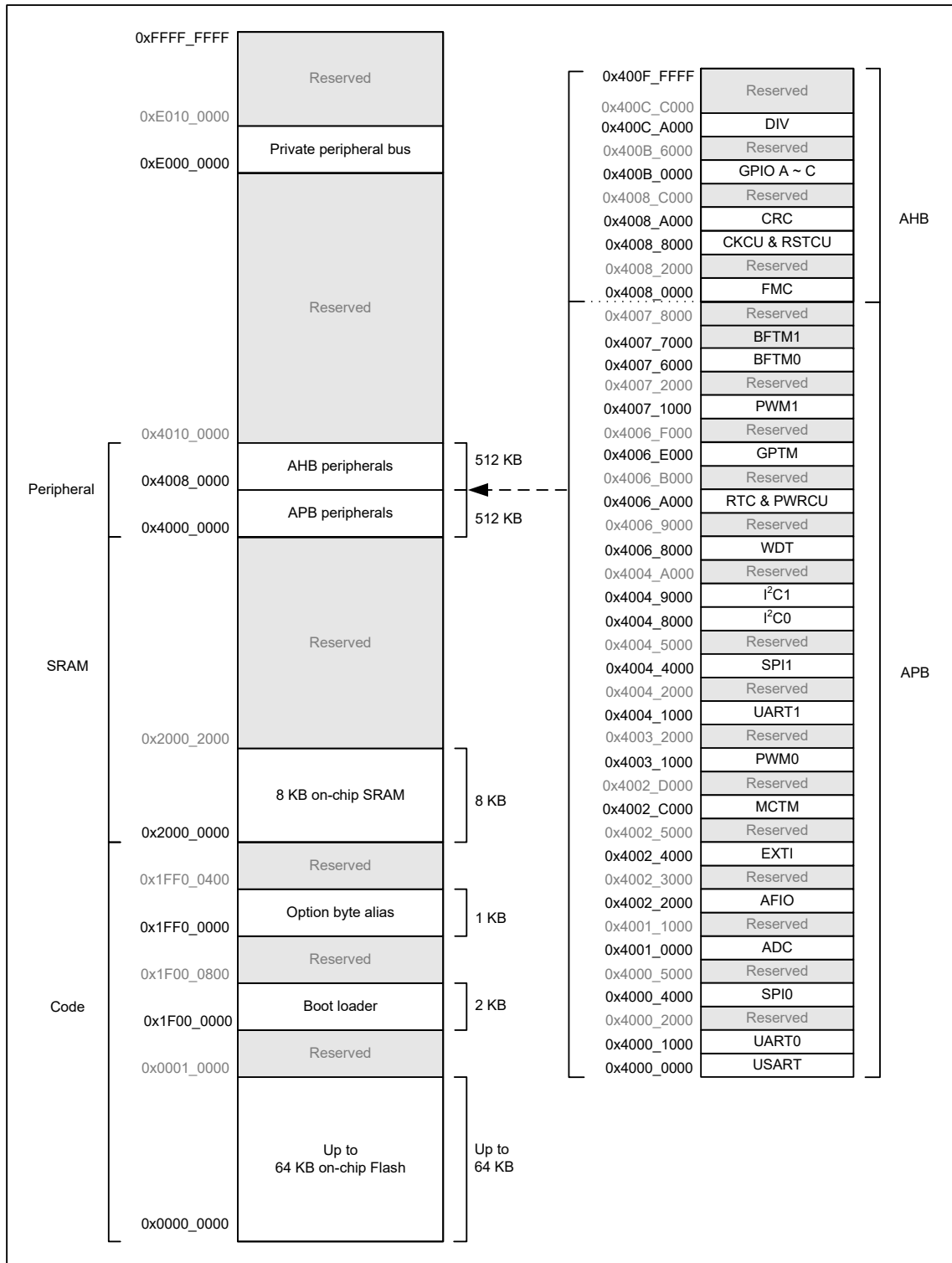

Figure 2. Memory Map

Table 2. Register Map

Start Address	End Address	Peripheral	Bus
0x4000_0000	0x4000_0FFF	USART	APB
0x4000_1000	0x4000_1FFF	UART0	
0x4000_2000	0x4000_3FFF	Reserved	
0x4000_4000	0x4000_4FFF	SPI0	
0x4000_5000	0x4000_FFFF	Reserved	
0x4001_0000	0x4001_0FFF	ADC	
0x4001_1000	0x4002_1FFF	Reserved	
0x4002_2000	0x4002_2FFF	AFIO	
0x4002_3000	0x4002_3FFF	Reserved	
0x4002_4000	0x4002_4FFF	EXTI	
0x4002_5000	0x4002_BFFF	Reserved	
0x4002_C000	0x4002_CFFF	MCTM	
0x4002_D000	0x4003_0FFF	Reserved	
0x4003_1000	0x4003_1FFF	PWM0	
0x4003_2000	0x4004_0FFF	Reserved	
0x4004_1000	0x4004_1FFF	UART1	
0x4004_2000	0x4004_3FFF	Reserved	
0x4004_4000	0x4004_4FFF	SPI1	
0x4004_5000	0x4004_7FFF	Reserved	
0x4004_8000	0x4004_8FFF	I ² C0	
0x4004_9000	0x4004_9FFF	I ² C1	
0x4004_A000	0x4006_7FFF	Reserved	
0x4006_8000	0x4006_8FFF	WDT	
0x4006_9000	0x4006_9FFF	Reserved	
0x4006_A000	0x4006_AFFF	RTC & PWRCU	
0x4006_B000	0x4006_DFFF	Reserved	
0x4006_E000	0x4006_EFFF	GPTM	
0x4006_F000	0x4007_0FFF	Reserved	
0x4007_1000	0x4007_1FFF	PWM1	
0x4007_2000	0x4007_5FFF	Reserved	
0x4007_6000	0x4007_6FFF	BFTM0	
0x4007_7000	0x4007_7FFF	BFTM1	
0x4007_8000	0x4007_FFFF	Reserved	

Start Address	End Address	Peripheral	Bus
0x4008_0000	0x4008_1FFF	FMC	AHB
0x4008_2000	0x4008_7FFF	Reserved	
0x4008_8000	0x4008_9FFF	CKCU & RSTCU	
0x4008_A000	0x4008_BFFF	CRC	
0x4008_C000	0x400A_FFFF	Reserved	
0x400B_0000	0x400B_1FFF	GPIO A	
0x400B_2000	0x400B_3FFF	GPIO B	
0x400B_4000	0x400B_5FFF	GPIO C	
0x400B_6000	0x400C_9FFF	Reserved	
0x400C_A000	0x400C_BFFF	DIV	
0x400C_C000	0x400F_FFFF	Reserved	

Clock Structure

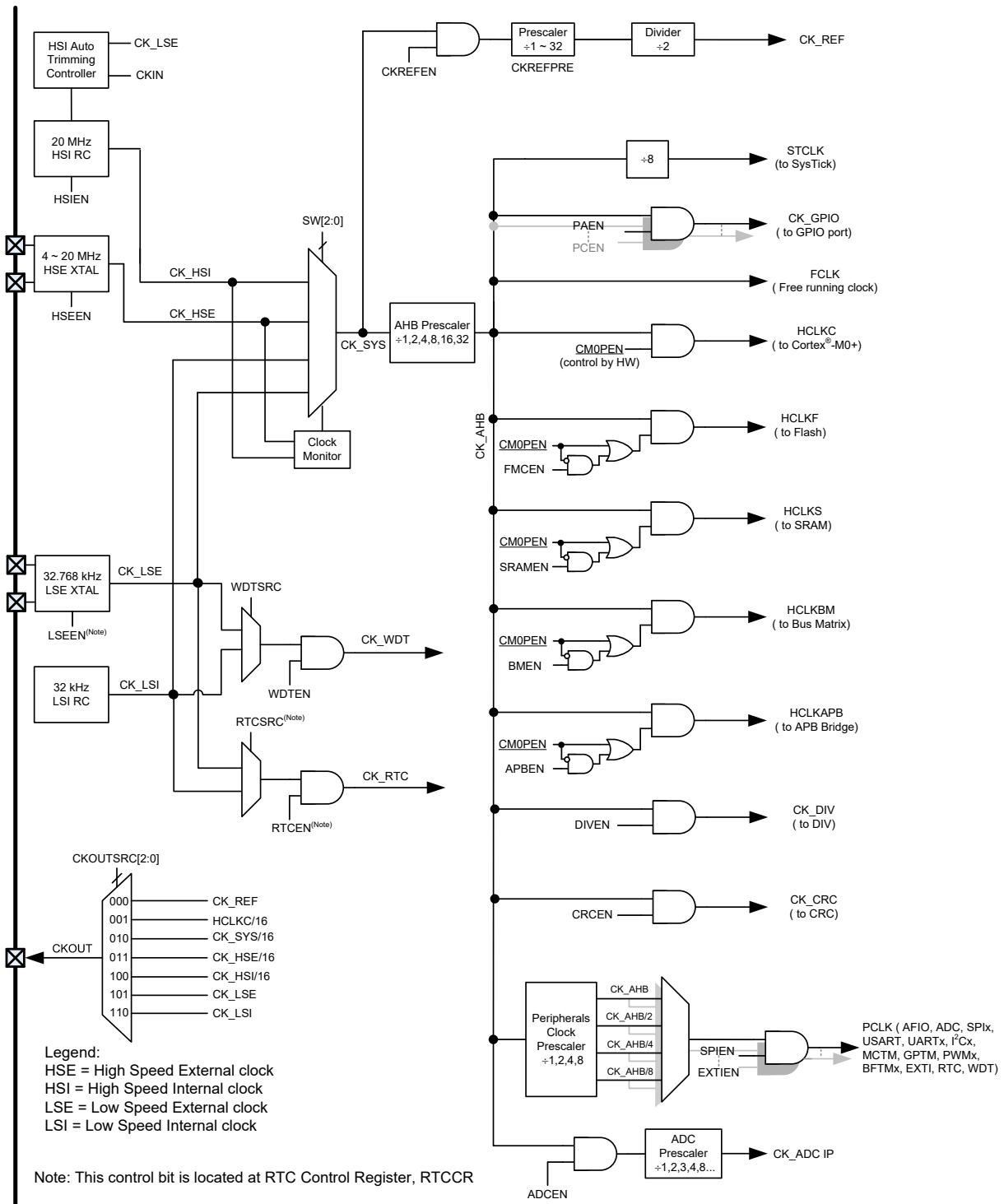

5 Pin Assignment

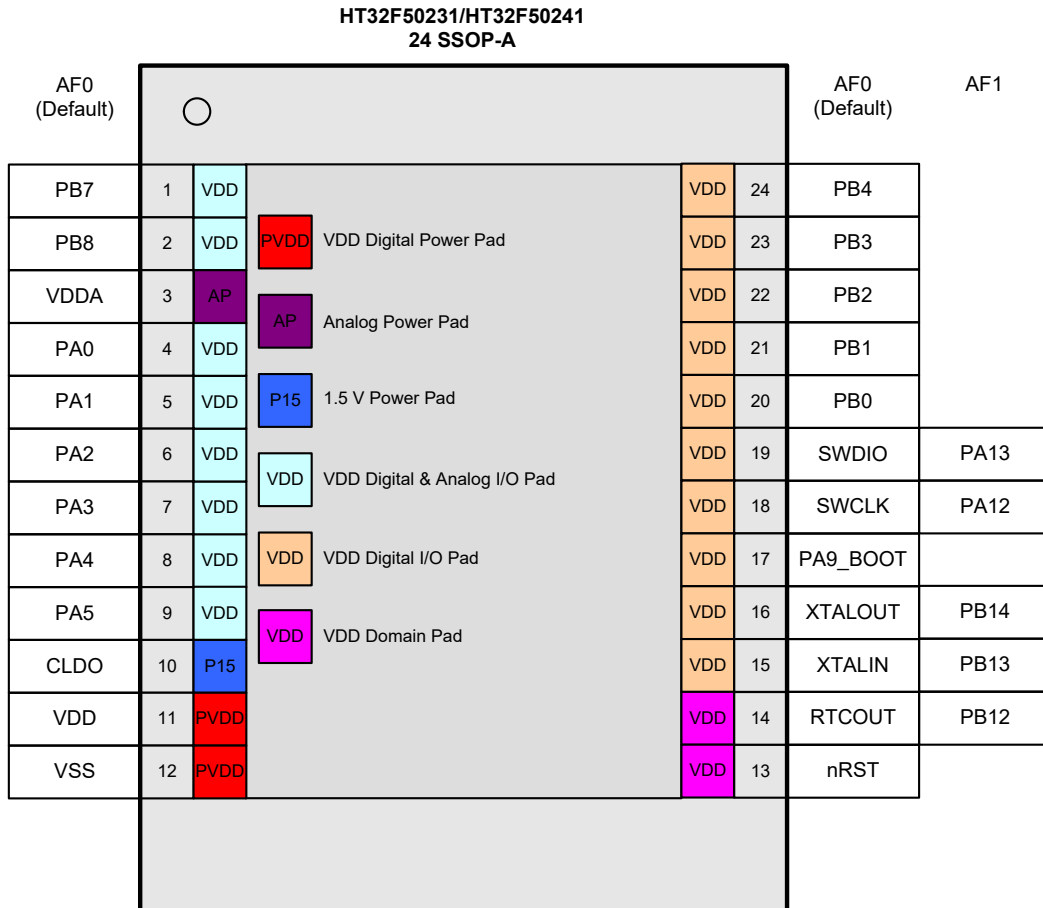
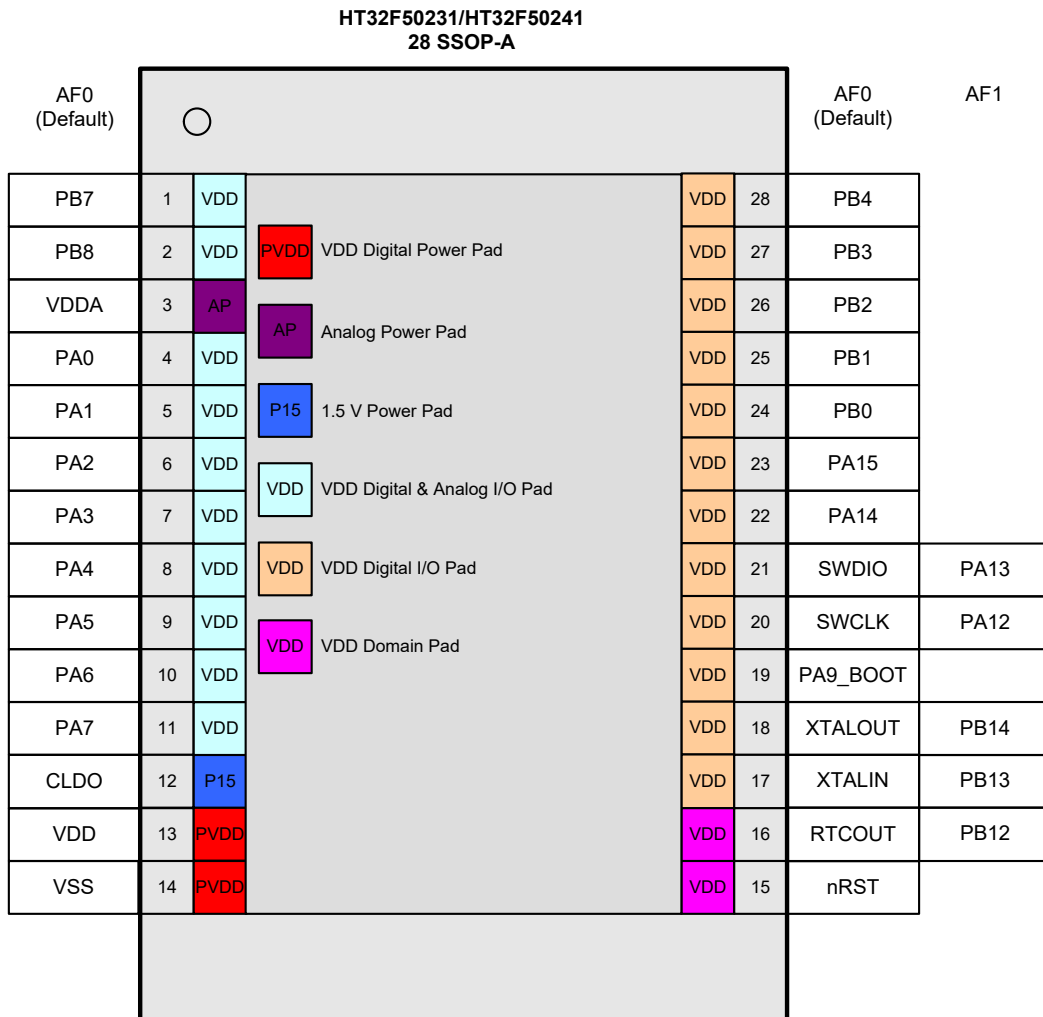

Figure 4. 24-pin SSOP Pin Assignment



5 Pin Assignment

Figure 5. 28-pin SSOP Pin Assignment



Figure 6. 28-pin SOP Pin Assignment

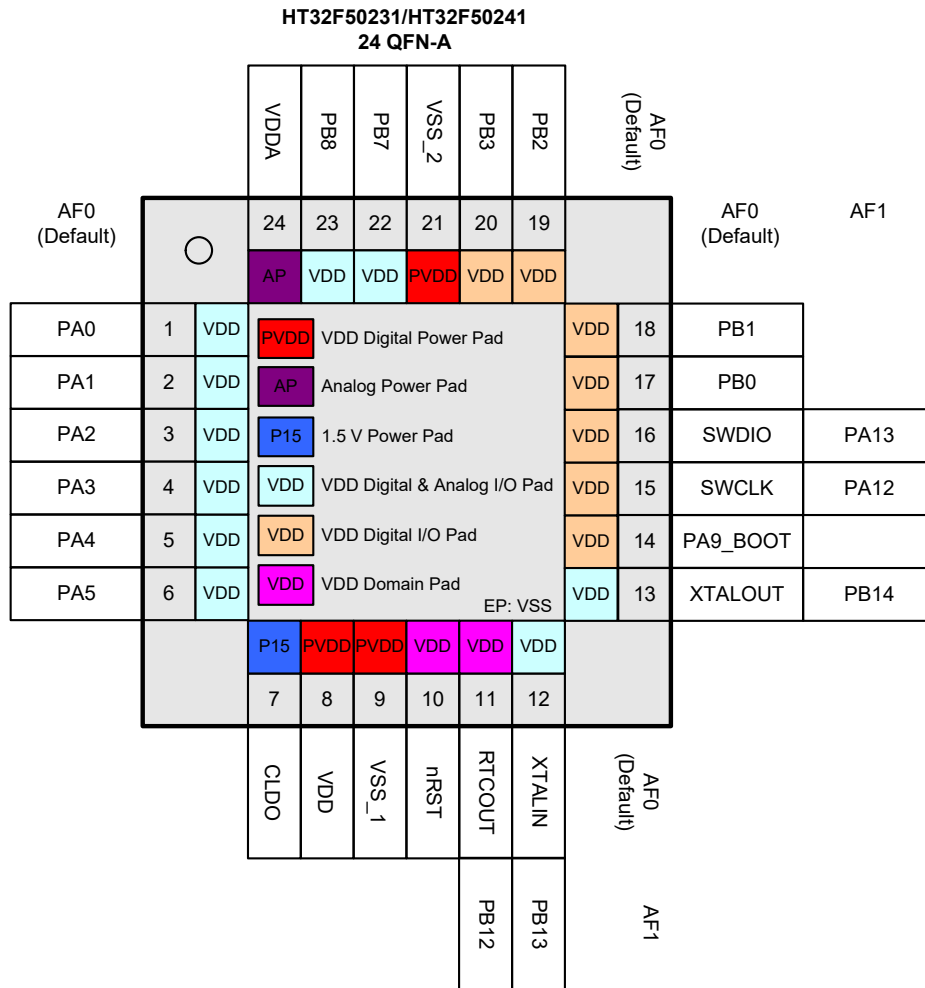

5 Pin Assignment

Figure 7. 24-pin QFN Pin Assignment

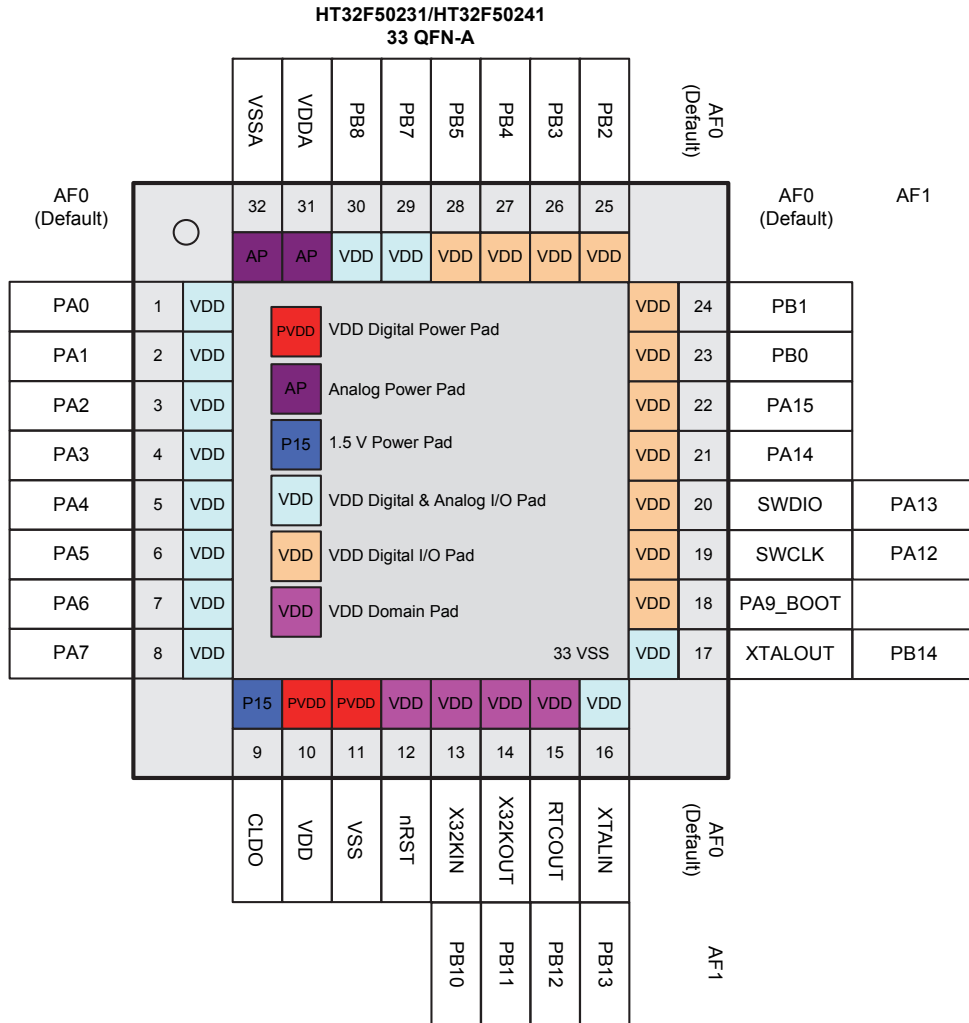
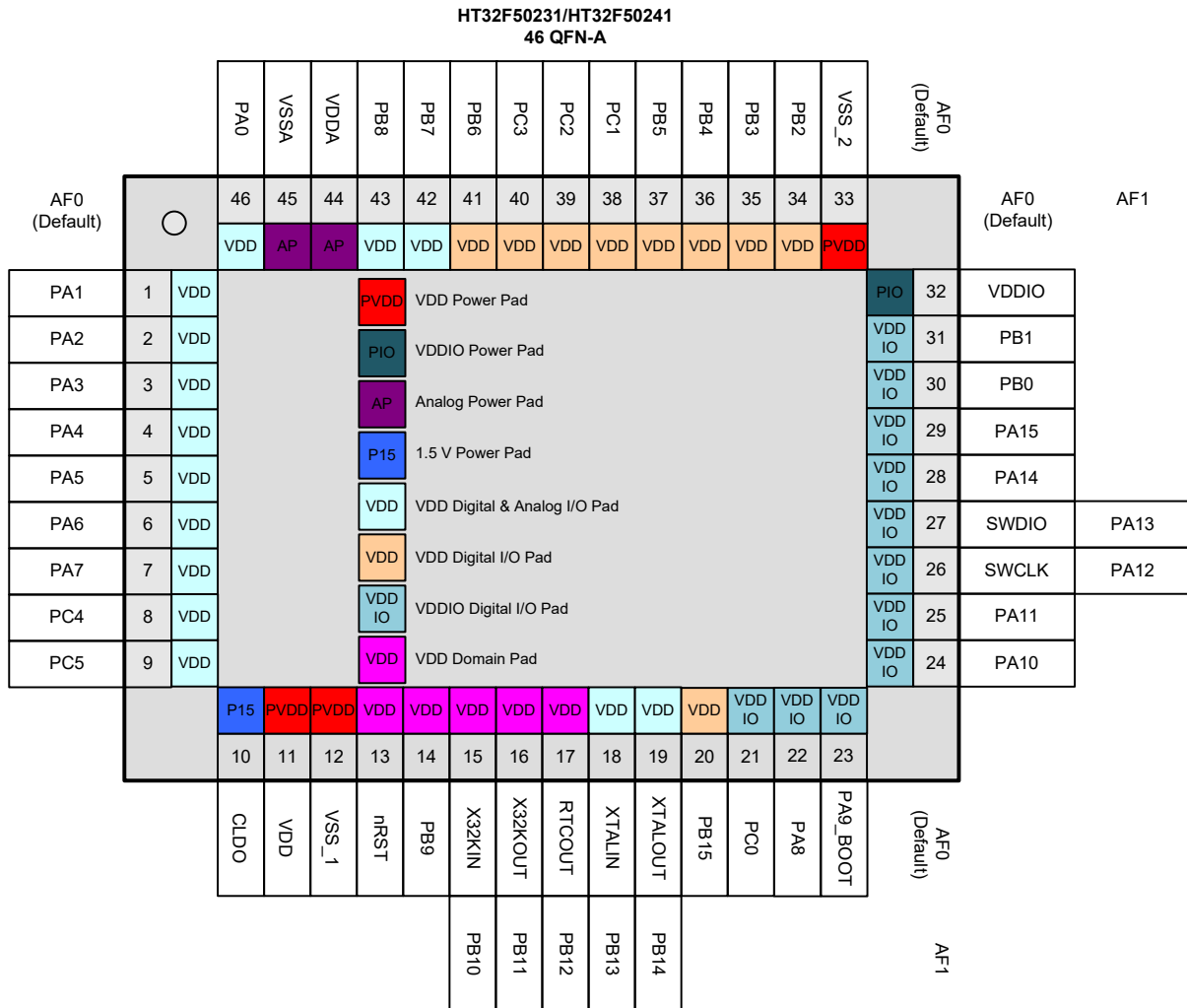
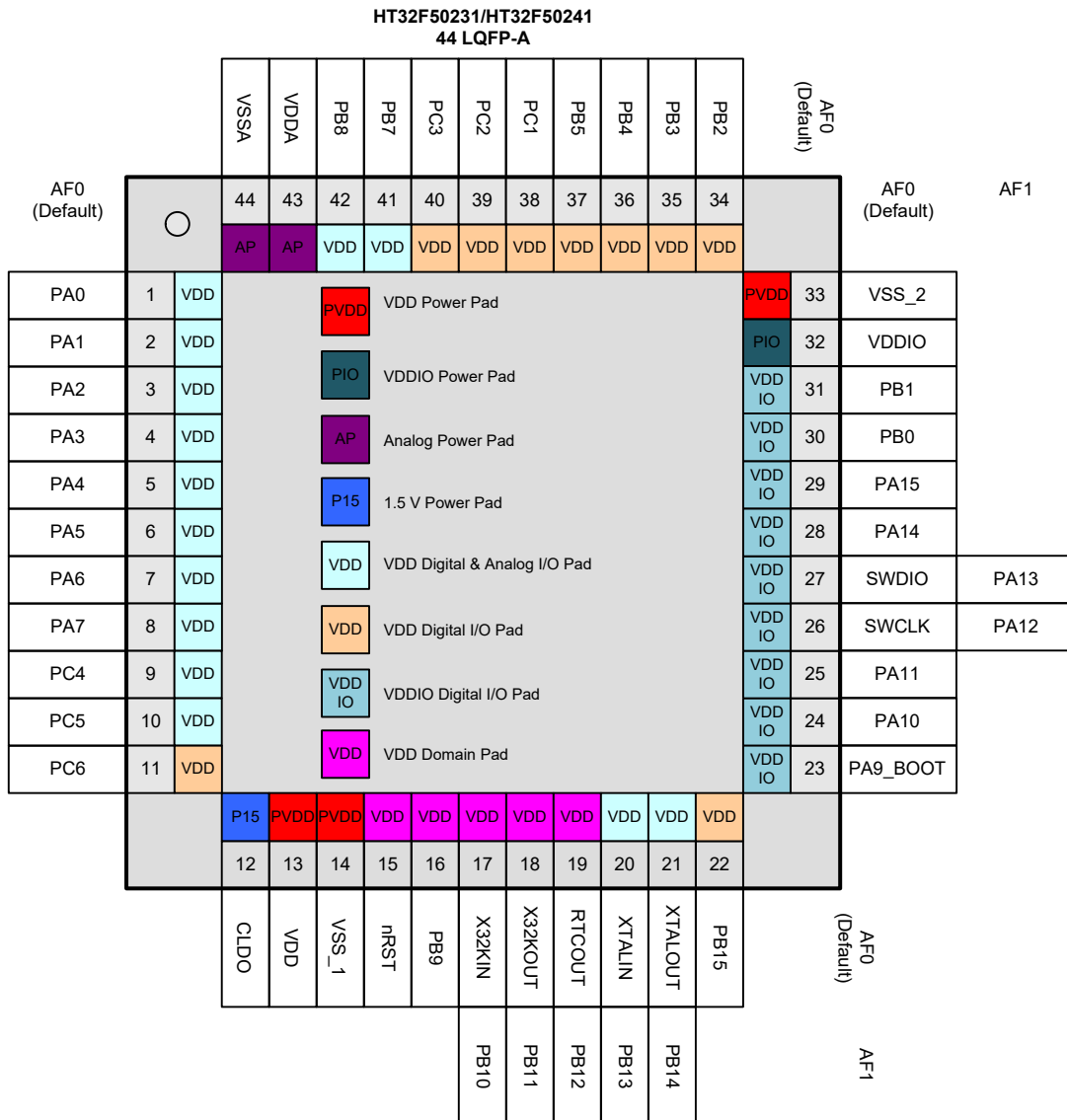

Figure 8. 33-pin QFN Pin Assignment



5 Pin Assignment

Figure 9. 46-pin QFN Pin Assignment



5 Pin Assignment

Figure 10. 44-pin LQFP Pin Assignment

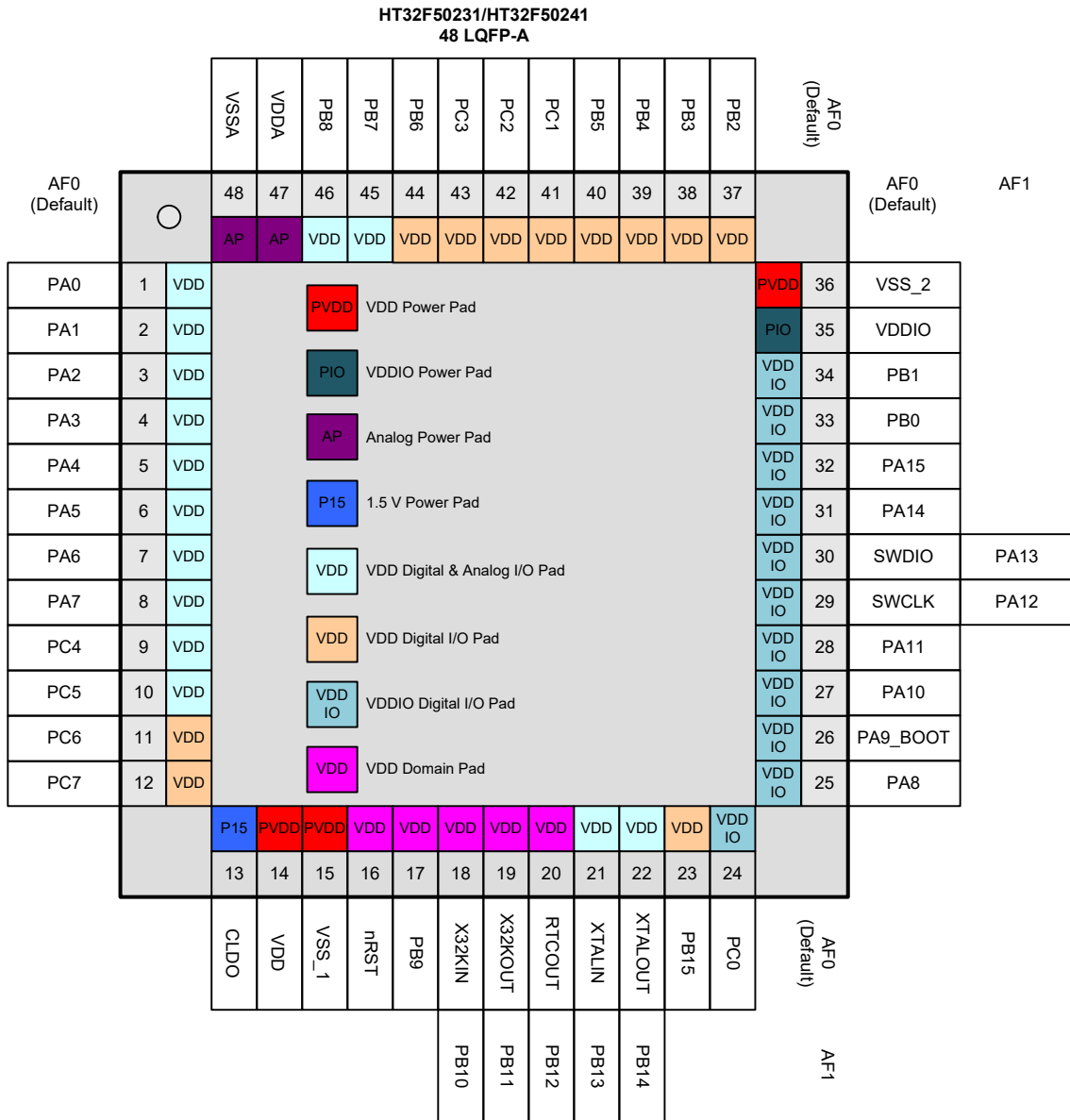

5 Pin Assignment

Figure 11. 48-pin LQFP Pin Assignment

Table 3. Pin Assignment

Packages								Alternate Function Mapping																
48 LQFP	46 QFN	44 LQFP	33 QFN	28 SOP	28 SSOP	24 SSOP	24 QFN	AF0 System Default	AF1 GPIO	AF2 ADC	AF3 N/A	AF4 MCTM /GPTM	AF5 SPI	AF6 USART /UART	AF7 I2C	AF8 N/A	AF9 N/A	AF10 N/A	AF11 N/A	AF12 N/A	AF13 PWM	AF14 N/A	AF15 System Other	
1	46	1	1	4	4	4	1	PA0		ADC_IN2		GT_CH0	SPI1_SCK	USR_RTS	I2C1_SCL									
2	1	2	2	5	5	5	2	PA1		ADC_IN3		GT_CH1	SPI1_MOSI	USR_CTS	I2C1_SDA									
3	2	3	3	6	6	6	3	PA2		ADC_IN4		GT_CH2	SPI1_MISO	USR_TX										
4	3	4	4	7	7	7	4	PA3		ADC_IN5		GT_CH3	SPI1_SEL	USR_RX										
5	4	5	5	8	8	8	5	PA4		ADC_IN6		GT_CH0	SPI0_SCK	UR1_TX	I2C0_SCL									
6	5	6	6	9	9	9	6	PA5		ADC_IN7		GT_CH1	SPI0_MOSI	UR1_RX	I2C0_SDA									
7	6	7	7	10	10			PA6		ADC_IN8		GT_CH2	SPI0_MISO											
8	7	8	8	11	11			PA7		ADC_IN9		GT_CH3	SPI0_SEL											
9	8	9						PC4		ADC_IN10				USR_TX								PWM1_CH0		
10	9	10						PC5		ADC_IN11				USR_RX								PWM1_CH1		
11		11						PC6				MT_CH2		UR0_TX	I2C0_SCL									
12								PC7				MT_CH2N		UR0_RX	I2C0_SDA									
13	10	12	9	12	12	10	7	CLDO																
14	11	13	10	13	13	11	8	VDD																
15	12	14	11	14	14	12	9	VSS_1																
16	13	15	12	15	15	13	10	nRST																
17	14	16						PB9				MT_CH3										PWM1_CH2		WAKEUP1
18	15	17	13					X32KIN	PB10			GT_CH0	SPI1_SEL	USR_TX								PWM1_CH3		
19	16	18	14					X32KOUT	PB11			GT_CH1	SPI1_SCK	USR_RX								PWM0_CH3		
20	17	19	15		16	14	11	RTCOU	PB12				SPI0_MISO	UR0_RX								PWM0_CH0		WAKEUP0
21	18	20	16	16	17	15	12	XTALIN	PB13					UR0_TX	I2C0_SCL									
22	19	21	17	17	18	16	13	XTALOUT	PB14					UR0_RX	I2C0_SDA									
23	20	22						PB15				MT_CH0	SPI0_SEL		I2C1_SCL							PWM0_CH1		
24	21							PC0				MT_CH0N	SPI0_SCK		I2C1_SDA							PWM0_CH2		
25	22							PA8						USR_TX								PWM1_CH3		
26	23	23	18	18	19	17	14	PA9_BOOT					SPI0_MOSI									PWM1_CH0		CKOUT
27	24	24		19				PA10				MT_CH1	SPI0_MOSI	USR_RX								PWM0_CH1		
28	25	25		20				PA11				MT_CH1N	SPI0_MISO									PWM0_CH2		
29	26	26	19	21	20	18	15	SWCLK	PA12															
30	27	27	20	22	21	19	16	SWDIO	PA13															
31	28	28	21	23	22			PA14				MT_CH0	SPI1_SEL	UR1_TX	I2C1_SCL							PWM0_CH0		
32	29	29	22	24	23			PA15				MT_CH0N	SPI1_SCK	UR1_RX	I2C1_SDA							PWM1_CH2		
33	30	30	23	25	24	20	17	PB0				MT_CH1	SPI1_MOSI	USR_TX	I2C0_SCL							PWM0_CH1		
34	31	31	24	26	25	21	18	PB1				MT_CH1N	SPI1_MISO	USR_RX	I2C0_SDA							PWM1_CH1		
35	32	32		27				VDDIO																
36	33	33	33				21	VSS_2																
37	34	34	25	28	26	22	19	PB2				MT_CH2	SPI0_SEL	UR1_TX								PWM0_CH2		CKIN
38	35	35	26		27	23	20	PB3				MT_CH2N	SPI0_SCK	UR1_RX								PWM1_CH2		

Packages								Alternate Function Mapping															
48 LQFP	46 QFN	44 LQFP	33 QFN	28 SOP	28 SSOP	24 SSOP	24 QFN	AF0	AF1	AF2	AF3	AF4	AF5	AF6	AF7	AF8	AF9	AF10	AF11	AF12	AF13	AF14	AF15
								System Default	GPIO	ADC	N/A	MCTM /GPTM	SPI	USART /UART	I2C	N/A	N/A	N/A	N/A	N/A	PWM	N/A	System Other
39	36	36	27		28	24		PB4				MT_BRK	SPI0_MOSI	UR1_TX								PWM0_CH3	
40	37	37	28					PB5				GT_CH2	SPI0_MISO	UR1_RX									
41	38	38						PC1				MT_CH0	SPI1_SEL	UR1_TX								PWM0_CH0	
42	39	39						PC2				MT_CH0N	SPI1_SCK									PWM1_CH0	
43	40	40						PC3				MT_BRK	SPI1_MOSI	UR1_RX								PWM1_CH1	
44	41							PB6				GT_CH3	SPI1_MISO	UR0_TX									
45	42	41	29	1	1	1	22	PB7		ADC_IN0		MT_CH1	SPI0_MISO	UR0_TX	I2C1_SCL							PWM0_CH3	
46	43	42	30	2	2	2	23	PB8		ADC_IN1		MT_CH1N	SPI0_SEL	UR0_RX	I2C1_SDA							PWM1_CH3	
47	44	43	31	3	3	3	24	VDDA															
48	45	44	32					VSSA															

Note: 1. For the 24QFN package, the EP VSS is internally connected to the pin number 21 and 9. The EP means the Exposed Pad of the QFN packages.
2. The pin number 33 of the 33QFN package is located at the exposed pad of the QFN package.

Table 4. Pin Description

Pin number								Pin Name	Type ⁽¹⁾	I/O Structure ⁽²⁾	Output Driving	Description	
48 LQFP	46 QFN	44 LQFP	33 QFN	28 SOP	28 SSOP	24 SSOP	24 QFN					Default function (AF0)	
1	46	1	1	4	4	4	1	PA0	A/I/O	5V	4/8/12/16 mA	PA0	
2	1	2	2	5	5	5	2	PA1	A/I/O	5V	4/8/12/16 mA	PA1	
3	2	3	3	6	6	6	3	PA2	A/I/O	5V	4/8/12/16 mA	PA2	
4	3	4	4	7	7	7	4	PA3	A/I/O	5V	4/8/12/16 mA	PA3	
5	4	5	5	8	8	8	5	PA4	A/I/O	5V	4/8/12/16 mA	PA4, this pin provides a UART_TX function in the Boot loader mode.	
6	5	6	6	9	9	9	6	PA5	A/I/O	5V	4/8/12/16 mA	PA5, this pin provides a UART_RX function in the Boot loader mode	
7	6	7	7	10	10			PA6	A/I/O	5V	4/8/12/16 mA	PA6	
8	7	8	8	11	11			PA7	A/I/O	5V	4/8/12/16 mA	PA7	
9	8	9						PC4	A/I/O	5V	4/8/12/16 mA	PC4	
10	9	10						PC5	A/I/O	5V	4/8/12/16 mA	PC5	
11		11						PC6	I/O	5V	4/8/12/16 mA	PC6	
12								PC7	I/O	5V	4/8/12/16 mA	PC7	
13	10	12	9	12	12	10	7	CLDO	P	—	—	Core power LDO VCORE output It must be connected a 2.2 μF capacitor as close as possible between this pin and VSS_1.	
14	11	13	10	13	13	11	8	VDD	P	—	—	Voltage for digital I/O	
15	12	14	11	14	14	12	9	VSS_1	P	—	—	Ground reference for digital I/O	
16	13	15	12	15	15	13	10	nRST ⁽³⁾	I	5V_PU	—	External reset pin	
17	14	16						PB9 ⁽³⁾	I/O (VDD)	5V	4/8/12/16 mA	PB9	
18	15	17	13					PB10 ⁽³⁾	A/I/O (VDD)	5V	4/8/12/16 mA	X32KIN	
19	16	18	14					PB11 ⁽³⁾	A/I/O (VDD)	5V	4/8/12/16 mA	X32KOUT	
20	17	19	15		16	14	11	PB12 ⁽³⁾	I/O (VDD)	5V	4/8/12/16 mA	RTCOUNT	

Pin number								Pin Name	Type ⁽¹⁾	I/O Structure ⁽²⁾	Output Driving	Description	
48 LQFP	46 QFN	44 LQFP	33 QFN	28 SOP	28 SSOP	24 SSOP	24 QFN					Default function (AF0)	
21	18	20	16	16	17	15	12	PB13	A/I/O	5V	4/8/12/16 mA	XTALIN	
22	19	21	17	17	18	16	13	PB14	A/I/O	5V	4/8/12/16 mA	XTALOUT	
23	20	22						PB15	I/O	5V	4/8/12/16 mA	PB15	
24	21							PC0	I/O (VDDIO)	5V	4/8/12/16 mA	PC0	
25	22							PA8	I/O (VDDIO)	5V	4/8/12/16 mA	PA8	
26	23	23	18	18	19	17	14	PA9	I/O (VDDIO)	5V_PU	4/8/12/16 mA	PA9_BOOT	
27	24	24		19				PA10	I/O (VDDIO)	5V	4/8/12/16 mA	PA10	
28	25	25		20				PA11	I/O (VDDIO)	5V	4/8/12/16 mA	PA11	
29	26	26	19	21	20	18	15	PA12	I/O (VDDIO)	5V_PU	4/8/12/16 mA	SWCLK	
30	27	27	20	22	21	19	16	PA13	I/O (VDDIO)	5V_PU	4/8/12/16 mA	SWDIO	
31	28	28	21	23	22			PA14	I/O (VDDIO)	5V	4/8/12/16 mA	PA14	
32	29	29	22	24	23			PA15	I/O (VDDIO)	5V	4/8/12/16 mA	PA15	
33	30	30	23	25	24	20	17	PB0	I/O (VDDIO)	5V	4/8/12/16 mA	PB0	
34	31	31	24	26	25	21	18	PB1	I/O (VDDIO)	5V	4/8/12/16 mA	PB1	
35	32	32		27				VDDIO	P	—	—	Voltage for digital I/O	
36	33	33	33				21	VSS_2	P	—	—	Ground reference for digital I/O	
37	34	34	25	28	26	22	19	PB2	I/O	5V	4/8/12/16 mA	PB2	
38	35	35	26		27	23	20	PB3	I/O	5V	4/8/12/16 mA	PB3	
39	36	36	27		28	24		PB4	I/O	5V	4/8/12/16 mA	PB4	
40	37	37	28					PB5	I/O	5V	4/8/12/16 mA	PB5	
41	38	38						PC1	I/O	5V	4/8/12/16 mA	PC1	
42	39	39						PC2	I/O	5V	4/8/12/16 mA	PC2	
43	40	40						PC3	I/O	5V	4/8/12/16 mA	PC3	
44	41							PB6	I/O	5V	4/8/12/16 mA	PB6	
45	42	41	29	1	1	1	22	PB7	A/I/O	5V	4/8/12/16 mA	PB7	
46	43	42	30	2	2	2	23	PB8	A/I/O	5V	4/8/12/16 mA	PB8	
47	44	43	31	3	3	3	24	VDDA	P	—	—	Analog voltage for ADC	
48	45	44	32					VSSA	P	—	—	Ground reference for the ADC	

Note: 1. I = input, O = output, A = Analog port, P = power supply, V_{DD} = V_{DD} Power.

2. 5V = 5 V operation I/O type, PU = Pull-up.

3. These pins are located at the V_{DD} power domain.

6 Electrical Characteristics

Absolute Maximum Ratings

The following table shows the absolute maximum ratings of the device. These are stress ratings only. Stresses beyond absolute maximum ratings may cause permanent damage to the device. Note that the device is not guaranteed to operate properly at the maximum ratings. Exposure to the absolute maximum rating conditions for extended periods may affect device reliability.

Table 5. Absolute Maximum Ratings

Symbol	Parameter	Min.	Max.	Unit
V _{DD}	External Main Supply Voltage	V _{SS} - 0.3	V _{SS} + 5.5	V
V _{DDIO}	External I/O Supply Voltage	V _{SS} - 0.3	V _{SS} + 5.5	V
V _{DDA}	External Analog Supply Voltage	V _{SSA} - 0.3	V _{SSA} + 5.5	V
V _{IN}	Input Voltage on I/O	V _{SS} - 0.3	V _{DD} + 0.3	V
T _A	Ambient Operating Temperature Range	-40	85	°C
T _{STG}	Storage Temperature Range	-60	150	°C
T _J	Maximum Junction Temperature	—	125	°C
P _D	Total Power Dissipation	—	500	mW
V _{ESD}	Electrostatic Discharge Voltage – Human Body Mode	-4000	+4000	V

Recommended DC Operating Conditions

Table 6. Recommended DC Operating Conditions

T_A = 25 °C, unless otherwise specified.

Symbol	Parameter	Conditions	Min.	Typ.	Max.	Unit
V _{DD}	Operating Voltage	—	2.5	5.0	5.5	V
V _{DDIO}	I/O Operating Voltage	—	1.8	5.0	5.5	V
V _{DDA}	Analog Operating Voltage	—	2.5	5.0	5.5	V

On-Chip LDO Voltage Regulator Characteristics

Table 7. LDO Characteristics

T_A = 25 °C, unless otherwise specified.

Symbol	Parameter	Conditions	Min.	Typ.	Max.	Unit
V _{LDO}	Internal Regulator Output Voltage	V _{DD} ≥ 2.5 V Regulator input @ I _{LDO} = 35 mA and voltage variant = ±5 %, After trimming	1.425	1.5	1.57	V
I _{LDO}	Output Current	V _{DD} = 2.5 V Regulator input @ V _{LDO} = 1.5 V	—	30	35	mA
C _{LDO}	External Filter Capacitor Value for Internal Core Power Supply	The capacitor value is dependent on the core power current consumption	1	2.2	—	μF

Power Consumption

Table 8. Power Consumption Characteristics

T_A = 25 °C, unless otherwise specified.

Symbol	Parameter	Conditions	Typ.	Max. @ T _A		Unit
				25 °C	85 °C	
I _{DD}	Supply Current (Run Mode)	V _{DD} = 5.0 V, HSI = 20 MHz, f _{CPU} = 20 MHz, f _{BUS} = 20 MHz, all peripherals enabled	6.5	7.2	—	mA
		V _{DD} = 5.0 V, HSI = 20 MHz, f _{CPU} = 20 MHz, f _{BUS} = 20 MHz, all peripherals disabled	4	4.5	—	
		V _{DD} = 5.0 V, HSI = 20 MHz, f _{CPU} = 10 MHz, f _{BUS} = 10 MHz, all peripherals enabled	3.5	3.9	—	
		V _{DD} = 5.0 V, HSI = 20 MHz, f _{CPU} = 10 MHz, f _{BUS} = 10 MHz, all peripherals disabled	2.25	2.5	—	
	Supply Current (Run Mode)	V _{DD} = 5.0 V, HSI off, LSI on, f _{CPU} = 32 kHz, f _{BUS} = 32 kHz, all peripherals enabled	32	41	—	μA
		V _{DD} = 5.0 V, HSI off, LSI on, f _{CPU} = 32 kHz, f _{BUS} = 32 kHz, all peripherals disabled	28	37	—	
	Supply Current (Sleep Mode)	V _{DD} = 5.0 V, HSI = 20 MHz, f _{CPU} = 0 MHz, f _{BUS} = 20 MHz, all peripherals enabled	3.5	3.9	—	mA
		V _{DD} = 5.0 V, HSI = 20 MHz, f _{CPU} = 0 MHz, f _{BUS} = 20 MHz, all peripherals disabled	0.8	0.92	—	
		V _{DD} = 5.0 V, HSI = 20 MHz, f _{CPU} = 0 MHz, f _{BUS} = 10 MHz, all peripherals enabled	2	2.25	—	
		V _{DD} = 5.0 V, HSI = 20 MHz, f _{CPU} = 0 MHz, f _{BUS} = 10 MHz, all peripherals disabled	0.65	0.75	—	
	Supply Current (Deep-Sleep1 Mode)	V _{DD} = 5.0 V, All clock off (HSE/HSI/LSE), LDO in low power mode, LSI on, RTC on	23	29	—	μA
Supply Current (Deep-Sleep2 Mode)	V _{DD} = 5.0 V, All clock off (HSE/HSI/LSE), LDO off, DMOS on, LSI on, RTC on	6.5	10	—		

- Note: 1. HSE means high speed external oscillator. HSI means 20 MHz high speed internal oscillator.
 2. LSE means 32.768 kHz low speed external oscillator. LSI means 32 kHz low speed internal oscillator.
 3. RTC means real time clock.
 4. Code = while (1) {208 NOP} executed in Flash.
 5. f_{BUS} means f_{HCLK} and f_{PCLK}.

Reset and Supply Monitor Characteristics

Table 9. V_{DD} Power Reset Characteristics

T_A = 25 °C, unless otherwise specified.

Symbol	Parameter	Conditions	Min.	Typ.	Max.	Unit
V _{POR}	Power On Reset Threshold (Rising Voltage on V _{DD})	T _A = -40 °C ~ 85 °C	2.22	2.35	2.48	V
V _{PDR}	Power Down Reset Threshold (Falling Voltage on V _{DD})		2.12	2.2	2.33	V
V _{PORHYST}	POR Hysteresis	—	—	150	—	mV
t _{POR}	Reset Delay Time	V _{DD} = 5.0 V	—	0.1	0.2	ms

Note: 1. Data based on characterization results only, not tested in production.

2. If the LDO is turned on, the V_{DD} POR has to be in the de-assertion condition. When the V_{DD} POR is in the assertion state then the LDO will be turned off.

Table 10. LVD/BOD Characteristics

T_A = 25 °C, unless otherwise specified.

Symbol	Parameter	Conditions	Min.	Typ.	Max.	Unit	
V _{BOD}	Voltage of Brown Out Detection	After factory-trimmed, V _{DD} Falling edge	2.37	2.45	2.53	V	
V _{LVD}	Voltage of Low Voltage Detection	V _{DD} Falling edge	LVDS = 000	2.57	2.65	2.73	V
			LVDS = 001	2.77	2.85	2.93	V
			LVDS = 010	2.97	3.05	3.13	V
			LVDS = 011	3.17	3.25	3.33	V
			LVDS = 100	3.37	3.45	3.53	V
			LVDS = 101	4.15	4.25	4.35	V
			LVDS = 110	4.35	4.45	4.55	V
LVDS = 111	4.55	4.65	4.75	V			
V _{LVDHTST}	LVD Hysteresis	V _{DD} = 5.0 V	—	—	100	mV	
t _{SULVD}	LVD Setup Time	V _{DD} = 5.0 V	—	—	5	μs	
t _{aiLVD}	LVD Active Delay Time	V _{DD} = 5.0 V	—	—	—	ms	
I _{DDLVD}	Operation Current ⁽²⁾	V _{DD} = 5.0 V	—	—	10	20	μA

Note: 1. Data based on characterization results only, not tested in production.

2. Bandgap current is not included.

3. LVDS field is in the PWRCU LVDCSR register.

External Clock Characteristics

Table 11. High Speed External Clock (HSE) Characteristics

$T_A = 25\text{ }^\circ\text{C}$, unless otherwise specified.

Symbol	Parameter	Conditions	Min.	Typ.	Max.	Unit
V_{DD}	Operation Range	$T_A = -40\text{ }^\circ\text{C} \sim 85\text{ }^\circ\text{C}$	2.5	—	5.5	V
f_{HSE}	High Speed External Oscillator Frequency (HSE)	$V_{DD} = 2.5\text{ V} \sim 5.0\text{ V}$	4	—	20	MHz
C_{LHSE}	Load Capacitance	$V_{DD} = 5.0\text{ V}$, $R_{ESR} = 100\ \Omega$ @ 20 MHz	—	—	12	pF
R_{FHSE}	Internal Feedback Resistor between XTALIN and XTALOUT pins	$V_{DD} = 5.0\text{ V}$	—	0.5	—	M Ω
R_{ESR}	Equivalent Series Resistance	$V_{DD} = 5.0\text{ V}$, $C_L = 12\text{ pF}$ @ 20 MHz, HSEDR = 0	—	—	110	Ω
		$V_{DD} = 2.5\text{ V}$, $C_L = 12\text{ pF}$ @ 20 MHz, HSEDR = 1	—	—	—	—
D_{HSE}	HSE Oscillator Duty Cycle	—	40	—	60	%
I_{DDHSE}	HSE Oscillator Current Consumption	$V_{DD} = 5.0\text{ V}$, $R_{ESR} = 100\ \Omega$, $C_L = 12\text{ pF}$ @ 8 MHz, HSEDR = 0	—	0.85	—	mA
		$V_{DD} = 5.0\text{ V}$, $R_{ESR} = 25\ \Omega$, $C_L = 12\text{ pF}$ @ 20 MHz, HSEDR = 1	—	3.0	—	—
I_{PWHSE}	HSE Oscillator Power Down Current	$V_{DD} = 5.0\text{ V}$	—	—	0.01	μA
t_{SUHSE}	HSE Oscillator Startup Time	$V_{DD} = 5.0\text{ V}$	—	—	4	ms

Table 12. Low Speed External Clock (LSE) Characteristics

$T_A = 25\text{ }^\circ\text{C}$, unless otherwise specified.

Symbol	Parameter	Conditions	Min	Typ	Max	Unit
V_{DD}	Operation Range	$T_A = -40\text{ }^\circ\text{C} \sim 85\text{ }^\circ\text{C}$	2.5	—	5.5	V
f_{CK_LSE}	LSE Frequency	$V_{DD} = 2.5\text{ V} \sim 5.5\text{ V}$	—	32.768	—	kHz
R_F	Internal Feedback Resistor	—	—	10	—	M Ω
R_{ESR}	Equivalent Series Resistance	$V_{DD} = 5.0\text{ V}$	30	—	TBD	k Ω
C_L	Recommended Load Capacitances	$V_{DD} = 5.0\text{ V}$	6	—	TBD	pF
I_{DDLSE}	Oscillator Supply Current (High current mode)	$f_{CK_LSE} = 32.768\text{ kHz}$, $R_{ESR} = 50\text{ k}\Omega$, $C_L \geq 7\text{ pF}$, $V_{DD} = 2.5\text{ V} \sim 5.5\text{ V}$, $T_A = -40\text{ }^\circ\text{C} \sim +85\text{ }^\circ\text{C}$	—	4.0	5.6	μA
	Oscillator Supply Current (Low Current Mode)	$f_{CK_LSE} = 32.768\text{ kHz}$, $R_{ESR} = 50\text{ k}\Omega$, $C_L < 7\text{ pF}$, $V_{DD} = 2.5\text{ V} \sim 5.5\text{ V}$, $T_A = -40\text{ }^\circ\text{C} \sim +85\text{ }^\circ\text{C}$	—	3.6	4.5	μA
	Power Down Current	—	—	—	0.01	μA
t_{SULSE}	Startup Time (Low Current Mode)	$f_{CK_LSI} = 32.768\text{ kHz}$, $V_{DD} = 2.5\text{ V} \sim 5.5\text{ V}$	500	—	—	ms

Note: The following guidelines are recommended to increase the stability of the crystal circuit of the HSE / LSE clock in the PCB layout:

1. The crystal oscillator should be located as close as possible to the MCU to keep the trace lengths as short as possible to reduce any parasitic capacitance.
2. Shield lines in the vicinity of the crystal by using a ground plane to isolate signals and reduce noise.
3. Keep any high frequency signal lines away from the crystal area to prevent any crosstalk adverse effects.

Internal Clock Characteristics

Table 13. High Speed Internal Clock (HSI) Characteristics

$T_A = 25\text{ }^\circ\text{C}$, unless otherwise specified.

Symbol	Parameter	Conditions	Min.	Typ.	Max.	Unit
V_{DD}	Operation Range	$T_A = -40\text{ }^\circ\text{C} \sim 85\text{ }^\circ\text{C}$	2.5	—	5.5	V
f_{HSI}	HSI Frequency	$V_{DD} = 5\text{ V} @ 25\text{ }^\circ\text{C}$	—	20	—	MHz
ACC_{HSI}	Factory Calibrated HSI Oscillator Frequency Accuracy	$V_{DD} = 5.0\text{ V}, T_A = 25\text{ }^\circ\text{C}$	-2	—	2	%
		$V_{DD} = 2.5\text{ V} \sim 5.5\text{ V}$ $T_A = -40\text{ }^\circ\text{C} \sim 85\text{ }^\circ\text{C}$	-3	—	3	%
Duty	Duty Cycle	$f_{HSI} = 20\text{ MHz}$	35	—	65	%
I_{DDHSI}	Oscillator Supply Current	$f_{HSI} = 20\text{ MHz} @$	—	—	140	μA
	Power Down Current	$V_{DD} = 2.5\text{ V} \sim 5.5\text{ V}$	—	—	0.01	μA
T_{SUHSI}	HSI Oscillator Startup time	$f_{HSI} = 20\text{ MHz}$	—	—	20	μs

Table 14. Low Speed Internal Clock (LSI) Characteristics

$T_A = 25\text{ }^\circ\text{C}$, unless otherwise specified.

Symbol	Parameter	Conditions	Min.	Typ.	Max.	Unit
V_{DD}	Operation Range	$T_A = -40\text{ }^\circ\text{C} \sim 85\text{ }^\circ\text{C}$	2.5	—	5.5	V
f_{LSI}	Low Speed Internal Oscillator Frequency (LSI)	$V_{DD} = 5.0\text{ V},$ $T_A = -40\text{ }^\circ\text{C} \sim 85\text{ }^\circ\text{C}$	21	32	43	kHz
ACC_{LSI}	LSI Frequency Accuracy	$V_{DD} = 5.0\text{ V},$ with factory-trimmed	-10	—	+10	%
$I_{DDL SI}$	LSI Oscillator Operating Current	$V_{DD} = 5.0\text{ V}$	—	0.5	0.8	μA
t_{SULSI}	LSI Oscillator Startup Time	$V_{DD} = 5.0\text{ V}$	—	—	100	μs

Memory Characteristics

Table 15. Flash Memory Characteristics

$T_A = 25\text{ }^\circ\text{C}$, unless otherwise specified.

Symbol	Parameter	Conditions	Min.	Typ.	Max.	Unit
N_{ENDU}	Number of Guaranteed Program / Erase Cycles before failure (Endurance)	$T_A = -40\text{ }^\circ\text{C} \sim 85\text{ }^\circ\text{C}$	20	—	—	K cycles
t_{RET}	Data Retention Time	$T_A = -40\text{ }^\circ\text{C} \sim 85\text{ }^\circ\text{C}$	10	—	—	Years
t_{PROG}	Word Programming Time	$T_A = -40\text{ }^\circ\text{C} \sim 85\text{ }^\circ\text{C}$	20	—	—	μs
t_{ERASE}	Page Erase Time	$T_A = -40\text{ }^\circ\text{C} \sim 85\text{ }^\circ\text{C}$	2	—	—	ms
t_{MERASE}	Mass Erase Time	$T_A = -40\text{ }^\circ\text{C} \sim 85\text{ }^\circ\text{C}$	10	—	—	ms

I/O Port Characteristics

Table 16. I/O Port Characteristics

$T_A = 25\text{ }^\circ\text{C}$, unless otherwise specified.

Symbol	Parameter	Conditions	Min.	Typ.	Max.	Unit	
I_{IL}	Low Level Input Current	5.0 V I/O	$V_I = V_{SS}$, On-chip pull-up resistor disabled	—	—	3	μA
		Reset pin		—	—	3	μA
I_{IH}	High Level Input Current	5.0 V I/O	$V_I = V_{DD}$, On-chip pull-down resistor disabled	—	—	3	μA
		Reset pin		—	—	3	μA

Symbol	Parameter	Conditions	Min.	Typ.	Max.	Unit
V _{IL}	Low Level Input Voltage	5.0 V I/O	-0.5	—	V _{DD} × 0.35	V
		Reset pin	-0.5	—	V _{DD} × 0.35	V
V _{IH}	High Level Input Voltage	5.0 V I/O	V _{DD} × 0.65	—	V _{DD} + 0.5	V
		Reset pin	V _{DD} × 0.65	—	V _{DD} + 0.5	V
V _{HYS}	Schmitt Trigger Input Voltage Hysteresis	5.0 V I/O	—	0.12 × V _{DD}	—	mV
		Reset pin	—	0.12 × V _{DD}	—	mV
I _{OL}	Low Level Output Current (GPIO Sink Current)	5.0 V I/O 4 mA drive, V _{OL} = 0.6 V	4	—	—	mA
		5.0 V I/O 8 mA drive, V _{OL} = 0.6 V	8	—	—	mA
		5.0 V I/O 12 mA drive, V _{OL} = 0.6 V	12	—	—	mA
		5.0 V I/O 16 mA drive, V _{OL} = 0.6 V	16	—	—	mA
I _{OH}	High Level Output Current (GPIO Source Current)	5.0 V I/O 4 mA drive, V _{OH} = V _{DD} - 0.6 V	—	4	—	mA
		5.0 V I/O 8 mA drive, V _{OH} = V _{DD} - 0.6 V	—	8	—	mA
		5.0 V I/O 12 mA drive, V _{OH} = V _{DD} - 0.6 V	—	12	—	mA
		5.0 V I/O 16 mA drive, V _{OH} = V _{DD} - 0.6 V	—	16	—	mA
V _{OL}	Low Level Output Voltage	5.0 V 4 mA drive I/O, I _{OL} = 4 mA	—	—	0.6	V
		5.0 V 8 mA drive I/O, I _{OL} = 8 mA	—	—	0.6	V
		5.0 V 12 mA drive I/O, I _{OL} = 12 mA	—	—	0.6	V
		5.0 V 16 mA drive I/O, I _{OL} = 16 mA	—	—	0.6	V
V _{OH}	High Level Output Voltage	5.0 V 4 mA drive I/O, I _{OH} = 4 mA	V _{DD} - 0.6	—	—	V
		5.0 V 8 mA drive I/O, I _{OH} = 8 mA	V _{DD} - 0.6	—	—	V
		5.0 V 12 mA drive I/O, I _{OH} = 12 mA	V _{DD} - 0.6	—	—	V
		5.0 V 16 mA drive I/O, I _{OH} = 16 mA	V _{DD} - 0.6	—	—	V
R _{PU}	Internal Pull-up Resistor	V _{DD} = 5.0 V	—	50	—	kΩ
		V _{DD} = 3.3 V	—	76	—	kΩ
R _{PD}	Internal Pull-down Resistor	V _{DD} = 5.0 V	—	50	—	kΩ
		V _{DD} = 3.3 V	—	76	—	kΩ

ADC Characteristics

Table 17. ADC Characteristics

$T_A = 25\text{ }^\circ\text{C}$, unless otherwise specified.

Symbol	Parameter	Conditions	Min.	Typ.	Max.	Unit
V_{DDA}	Operating Voltage	—	2.5	5.0	5.5	V
V_{ADCIN}	A/D Converter Input Voltage Range	—	0	—	V_{REF+}	V
V_{REF+}	A/D Converter Reference Voltage	—	—	V_{DDA}	V_{DDA}	V
I_{ADC}	Current Consumption	$V_{DDA} = 5.0\text{ V}$	—	1.4	1.5	mA
I_{ADC_DN}	Power Down Current Consumption	$V_{DDA} = 5.0\text{ V}$	—	—	0.1	μA
f_{ADC}	A/D Converter Clock Frequency	—	0.7	—	16	MHz
f_S	Sampling Rate	—	0.05	—	1	Msp/s
t_{DL}	Data Latency	—	—	12.5	—	$1/f_{ADC}$ Cycles
$t_{S\&H}$	Sampling & Hold Time	—	—	3.5	—	$1/f_{ADC}$ Cycles
$t_{ADCCONV}$	A/D Converter Conversion Time	ADST[7:0] = 2	—	16	—	$1/f_{ADC}$ Cycles
R_i	Input Sampling Switch Resistance	—	—	—	1	k Ω
C_i	Input Sampling Capacitance	No pin / pad capacitance included	—	4	—	pF
t_{SU}	Startup Time	—	—	—	1	μs
N	Resolution	—	—	12	—	bits
INL	Integral Non-linearity Error	$f_S = 750\text{ ksp/s}$, $V_{DDA} = 5.0\text{ V}$	—	± 2	± 5	LSB
DNL	Differential Non-linearity Error	$f_S = 750\text{ ksp/s}$, $V_{DDA} = 5.0\text{ V}$	—	± 1	—	LSB
E_O	Offset Error	—	—	—	± 10	LSB
E_G	Gain Error	—	—	—	± 10	LSB

Note: 1. Data based on characterization results only, not tested in production.

2. Due to the A/D Converter input channel and GPIO pin-shared function design limitation, the V_{DDA} supply power of the A/D Converter has to be equal to the V_{DD} supply power of the MCU in the application circuit.

3. The figure below shows the equivalent circuit of the A/D Converter Sample-and-Hold input stage where C_i is the storage capacitor, R_i is the resistance of the sampling switch and R_s is the output impedance of the signal source V_s . Normally the sampling phase duration is approximately, $3.5/f_{ADC}$. The capacitance, C_i , must be charged within this time frame and it must be ensured that the voltage at its terminals becomes sufficiently close to V_s for accuracy. To guarantee this, R_s is not allowed to have an arbitrarily large value.

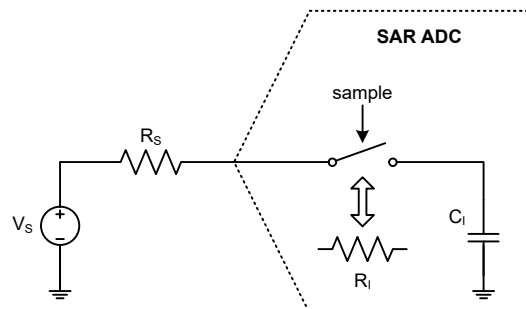

Figure 12. ADC Sampling Network Model

The worst case occurs when the extremities of the input range (0 V and V_{REF}) are sampled consecutively. In this situation a sampling error below 1/4 LSB is ensured by using the following equation:

$$R_S < \frac{3.5}{f_{ADC} C_I \ln(2^{N+2})} - R_I$$

Where f_{ADC} is the ADC clock frequency and N is the ADC resolution (N = 12 in this case). A safe margin should be considered due to the pin/pad parasitic capacitances, which are not accounted for in this simple model.

If, in a system where the A/D Converter is used, there are no rail-to-rail input voltage variations between consecutive sampling phases, R_S may be larger than the value indicated by the equation above.

MCTM/GPTM/PWM Characteristics

Table 18. MCTM/GPTM/PWM Characteristics

Symbol	Parameter	Conditions	Min.	Typ.	Max.	Unit
f_{TM}	Timer Clock Source for MCTM, GPTM and PWM	—	—	—	f_{PCLK}	MHz
t_{RES}	Timer Resolution Time	—	1	—	—	f_{TM}
f_{EXT}	External Single Frequency on Channel 1 ~ 4	—	—	—	1/2	f_{TM}
RES	Timer Resolution	—	—	—	16	Bits

I²C Characteristics

Table 19. I²C Characteristics

Symbol	Parameter	Standard Mode		Fast Mode		Fast Plus Mode		Unit
		Min.	Max.	Min.	Max.	Min.	Max.	
f_{SCL}	SCL Clock Frequency	—	100	—	400	—	1000	kHz
$t_{SCL(H)}$	SCL Clock High Time	4.5	—	1.125	—	0.45	—	μs
$t_{SCL(L)}$	SCL Clock Low Time	4.5	—	1.125	—	0.45	—	μs
t_{FALL}	SCL And SDA Fall Time	—	1.3	—	0.34	—	0.135	μs
t_{RISE}	SCL And SDA Rise Time	—	1.3	—	0.34	—	0.135	μs
$t_{SU(SDA)}$	SDA Data Setup Time	500	—	125	—	50	—	ns
$t_{H(SDA)}$	SDA Data Hold Time ^(Note 5)	0	—	0	—	0	—	ns
	SDA Data Hold Time ^(Note 6)	100	—	100	—	100	—	ns
$t_{VD(SDA)}$	SDA Data Valid Time	—	1.6	—	0.475	—	0.25	μs
$t_{SU(STA)}$	START Condition Setup Time	500	—	125	—	50	—	ns
$t_{H(STA)}$	START Condition Hold Time	0	—	0	—	0	—	ns
$t_{SU(STO)}$	STOP Condition Setup Time	500	—	125	—	50	—	ns

Note: 1. Data based on characterization results only, not tested in production.

2. To achieve 100 kHz standard mode, the peripheral clock frequency must be higher than 2 MHz.

3. To achieve 400 kHz fast mode, the peripheral clock frequency must be higher than 8 MHz.

4. To achieve 1 MHz fast mode plus, the peripheral clock frequency must be higher than 20 MHz.

5. The above characteristic parameters of the I²C bus timing are based on: COMBFILTEREN = 0 and SEQFILTER = 00.

6. The above characteristic parameters of the I²C bus timing are based on: COMBFILTEREN = 1 and SEQFILTER = 00.

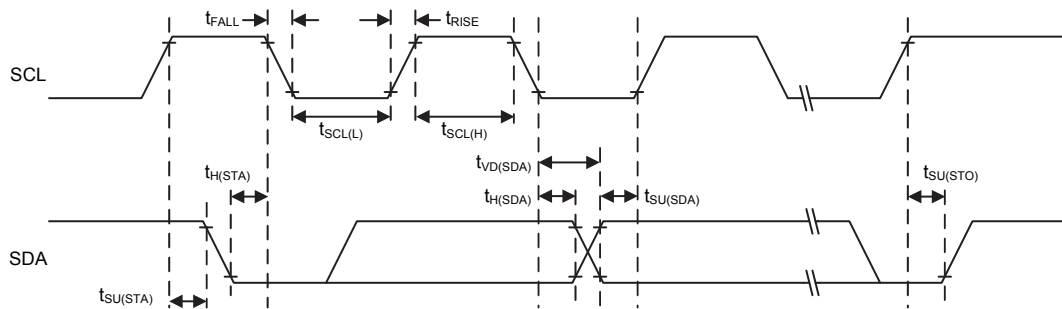

Figure 13. I²C Timing Diagrams

SPI Characteristics

Table 20. SPI Characteristics

Symbol	Parameter	Conditions	Min.	Typ.	Max.	Unit
SPI Master Mode						
f_{SCK}	SPI Master Output SCK Clock Frequency	Master mode, SPI peripheral clock frequency f_{PCLK}	—	—	$f_{PCLK}/2$	MHz
$t_{SCK(H)}$ $t_{SCK(L)}$	SCK Clock High and Low Time	—	$t_{SCK}/2 - 2$	—	$t_{SCK}/2 + 1$	ns
$t_{V(MO)}$	Data Output Valid Time	—	—	—	5	ns
$t_{H(MO)}$	Data Output Hold Time	—	2	—	—	ns
$t_{SU(MI)}$	Data Input Setup Time	—	5	—	—	ns
$t_{H(MI)}$	Data Input Hold Time	—	5	—	—	ns
SPI Slave Mode						
f_{SCK}	SPI Slave Input SCK Clock Frequency	Slave mode, SPI peripheral clock frequency f_{PCLK}	—	—	$f_{PCLK}/3$	MHz
Duty _{SCK}	SPI Slave Input SCK Clock Duty Cycle	—	30	—	70	%
$t_{SU(SEL)}$	SEL Enable Setup Time	—	$3 t_{PCLK}$	—	—	ns
$t_{H(SEL)}$	SEL Enable Hold Time	—	$2 t_{PCLK}$	—	—	ns
$t_{A(SO)}$	Data Output Access Time	—	—	—	$3 t_{PCLK}$	ns
$t_{DIS(SO)}$	Data Output Disable Time	—	—	—	10	ns
$t_{V(SO)}$	Data Output Valid Time	—	—	—	25	ns
$t_{H(SO)}$	Data Output Hold Time	—	15	—	—	ns
$t_{SU(SI)}$	Data Input Setup Time	—	5	—	—	ns
$t_{H(SI)}$	Data Input Hold Time	—	4	—	—	ns

Note: 1. f_{SCK} is SPI output/input clock frequency and $t_{SCK} = 1/f_{SCK}$.
2. f_{PCLK} is SPI peripheral clock frequency and $t_{PCLK} = 1/f_{PCLK}$.

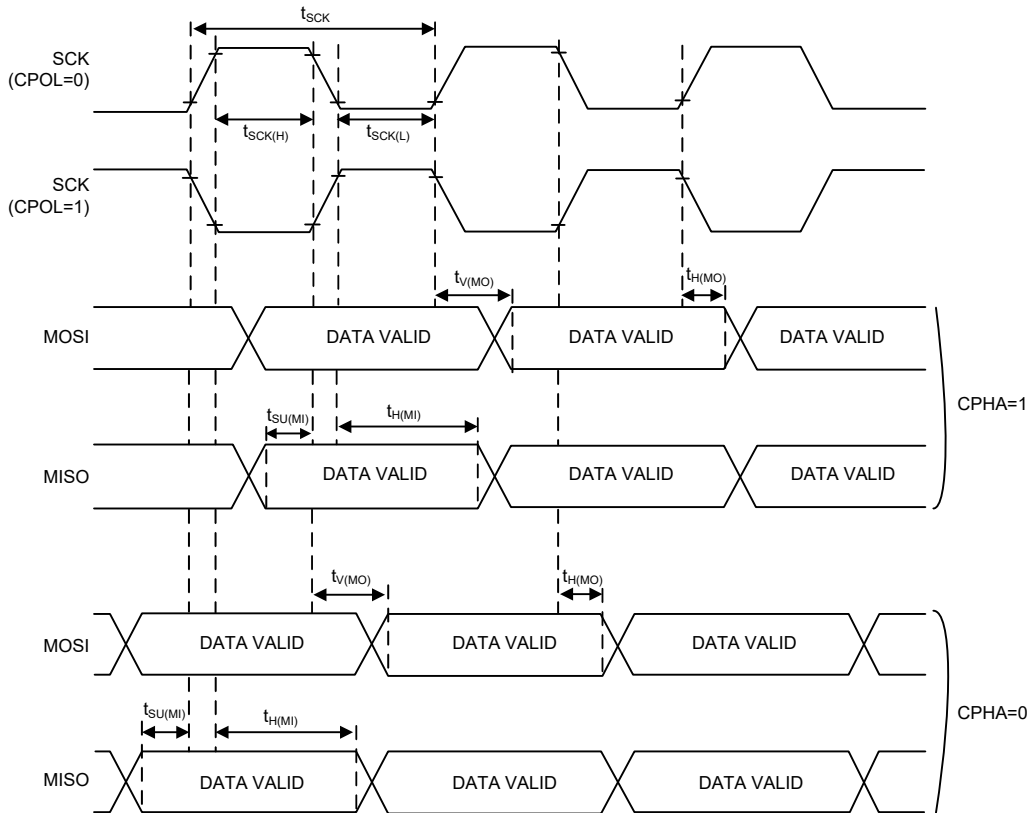

Figure 14. SPI Timing Diagrams – SPI Master Mode

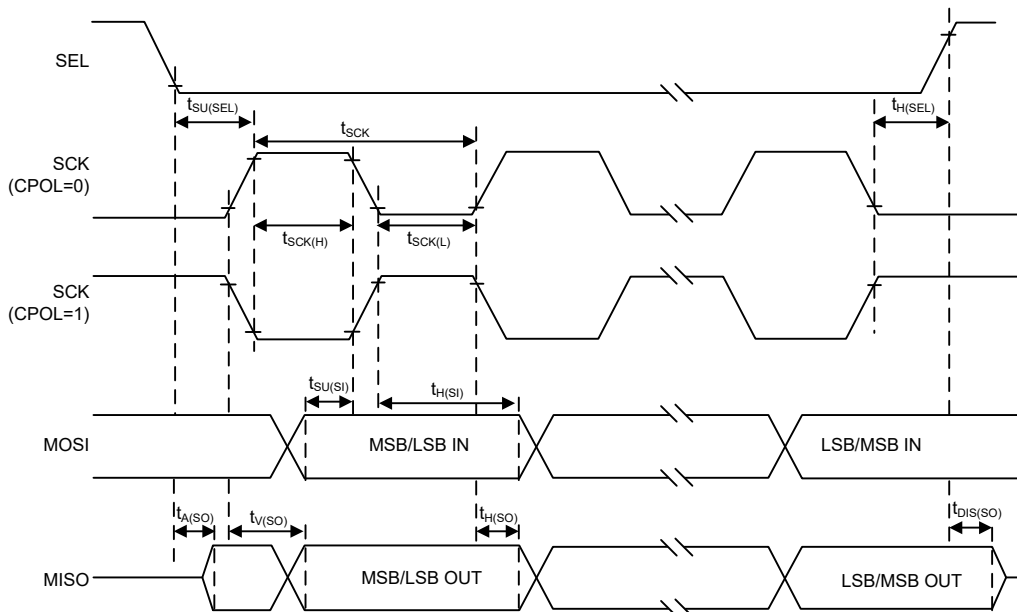

Figure 15. SPI Timing Diagrams – SPI Slave Mode with CPHA=1

7 Package Information

Note that the package information provided here is for consultation purposes only. As this information may be updated at regular intervals users are reminded to consult the [Holtek website](#) for the latest version of the [Package/Carton Information](#).

Additional supplementary information with regard to packaging is listed below. Click on the relevant section to be transferred to the relevant website page.

- Package Information (include Outline Dimensions, Product Tape and Reel Specifications)
- The Operation Instruction of Packing Materials
- Carton information

24-pin SSOP (150mil) Outline Dimensions

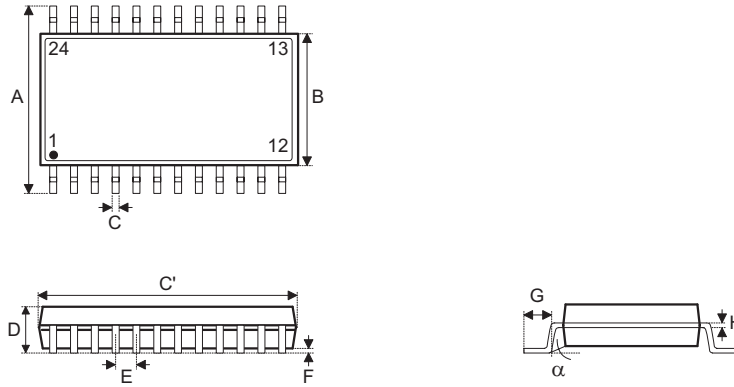

Symbol	Dimensions in inch		
	Min.	Nom.	Max.
A	0.236 BSC		
B	0.154 BSC		
C	0.008	—	0.012
C'	0.341 BSC		
D	—	—	0.069
E	0.025 BSC		
F	0.004	—	0.010
G	0.016	—	0.050
H	0.004	—	0.010
α	0°	—	8°

Symbol	Dimensions in mm		
	Min.	Nom.	Max.
A	6.00 BSC		
B	3.90 BSC		
C	0.20	—	0.30
C'	8.66 BSC		
D	—	—	1.75
E	0.635 BSC		
F	0.10	—	0.25
G	0.41	—	1.27
H	0.10	—	0.25
α	0°	—	8°

28-pin SSOP (150mil) Outline Dimensions

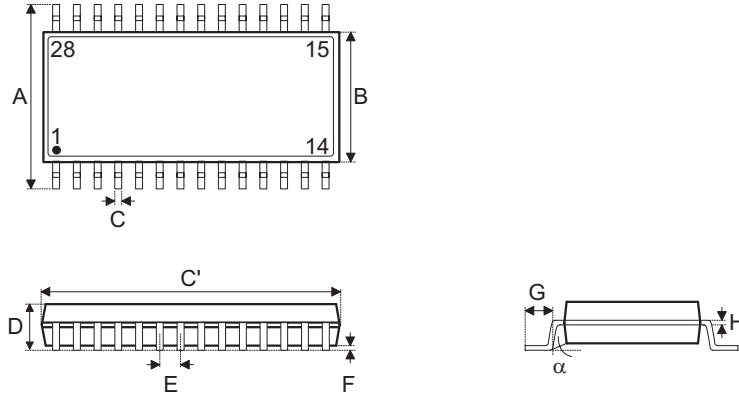

Symbol	Dimensions in inch		
	Min.	Nom.	Max.
A		0.236 BSC	
B		0.154 BSC	
C	0.008	—	0.012
C'		0.390 BSC	
D	—	—	0.069
E		0.025 BSC	
F	0.004	—	0.010
G	0.016	—	0.050
H	0.004	—	0.010
α	0°	—	8°

Symbol	Dimensions in mm		
	Min.	Nom.	Max.
A		6.00 BSC	
B		3.90 BSC	
C	0.20	—	0.30
C'		9.90 BSC	
D	—	—	1.75
E		0.635 BSC	
F	0.10	—	0.25
G	0.41	—	1.27
H	0.10	—	0.25
α	0°	—	8°

28-pin SOP (300mil) Outline Dimensions

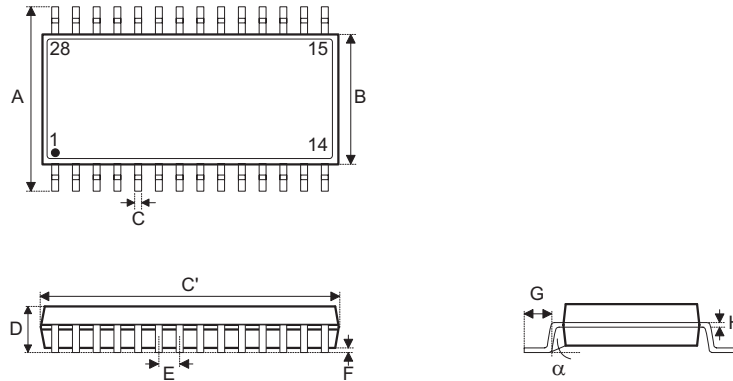

Symbol	Dimensions in inch		
	Min.	Nom.	Max.
A	0.406 BSC		
B	0.295 BSC		
C	0.012	—	0.020
C'	0.705 BSC		
D	—	—	0.104
E	0.050 BSC		
F	0.004	—	0.012
G	0.016	—	0.050
H	0.008	—	0.013
α	0°	—	8°

Symbol	Dimensions in mm		
	Min.	Nom.	Max.
A	10.30 BSC		
B	7.50 BSC		
C	0.31	—	0.51
C'	17.90 BSC		
D	—	—	2.65
E	1.27 BSC		
F	0.10	—	0.30
G	0.40	—	1.27
H	0.20	—	0.33
α	0°	—	8°

SAW Type 24-pin QFN (3mm×3mm×0.55mm) Outline Dimensions

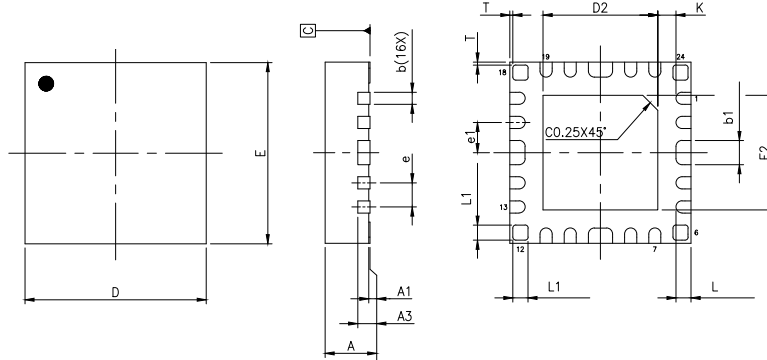

Symbol	Dimensions in inch		
	Min.	Nom.	Max.
A	0.020	0.022	0.024
A1	0.000	0.001	0.002
A3	0.006 REF		
b	0.006	0.008	0.010
b1	0.014	0.016	0.018
D	0.118 BSC		
E	0.118 BSC		
e	0.016 BSC		
e1	0.020 BSC		
D2	0.073	—	0.077
E2	0.073	—	0.077
L	0.006	0.010	0.014
L1	0.008	0.010	0.012
K	0.008	—	—
T	0.000	0.002	0.004

Symbol	Dimensions in mm		
	Min.	Nom.	Max.
A	0.50	0.55	0.60
A1	0.00	0.02	0.05
A3	0.15 REF		
b	0.15	0.20	0.25
b1	0.35	0.40	0.45
D	3.00 BSC		
E	3.00 BSC		
e	0.40 BSC		
e1	0.50 BSC		
D2	1.85	—	1.95
E2	1.85	—	1.95
L	0.15	0.25	0.35
L1	0.20	0.25	0.30
K	0.20	—	—
T	0.00	0.05	0.10

SAW Type 33-pin QFN (4mm×4mm×0.75mm) Outline Dimensions

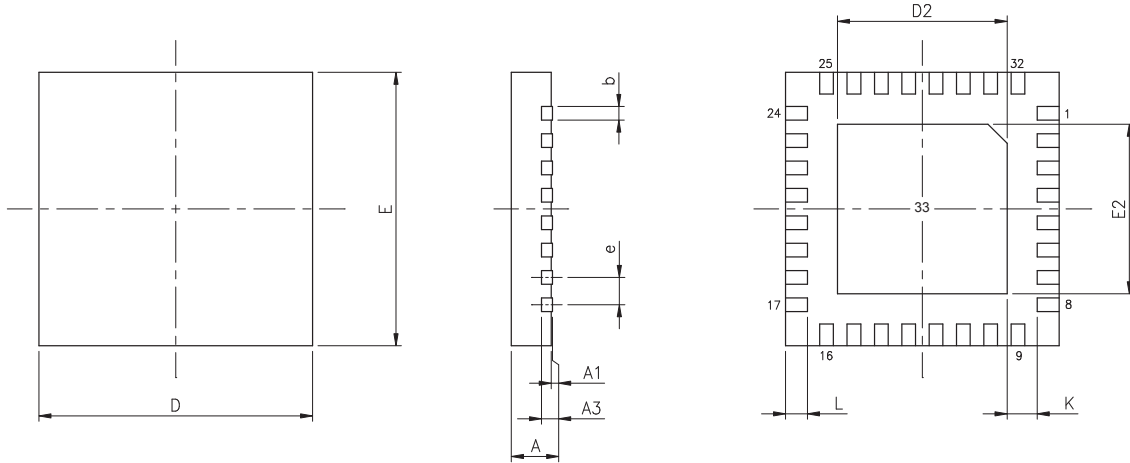

Symbol	Dimensions in inch		
	Min.	Nom.	Max.
A	0.028	0.030	0.031
A1	0.000	0.001	0.002
A3	0.008 REF		
b	0.006	0.008	0.010
D	0.157 BSC		
E	0.157 BSC		
e	0.016 BSC		
D2	0.100	—	0.108
E2	0.100	—	0.108
L	0.014	0.016	0.018
K	0.008	—	—

Symbol	Dimensions in mm		
	Min.	Nom.	Max.
A	0.70	0.75	0.80
A1	0.00	0.02	0.05
A3	0.203 REF		
b	0.15	0.20	0.25
D	4.00 BSC		
E	4.00 BSC		
e	0.40 BSC		
D2	2.55	—	2.75
E2	2.55	—	2.75
L	0.35	0.40	0.45
K	0.20	—	—

SAW Type 46-pin QFN (6.5mm×4.5mm×0.75mm) Outline Dimensions

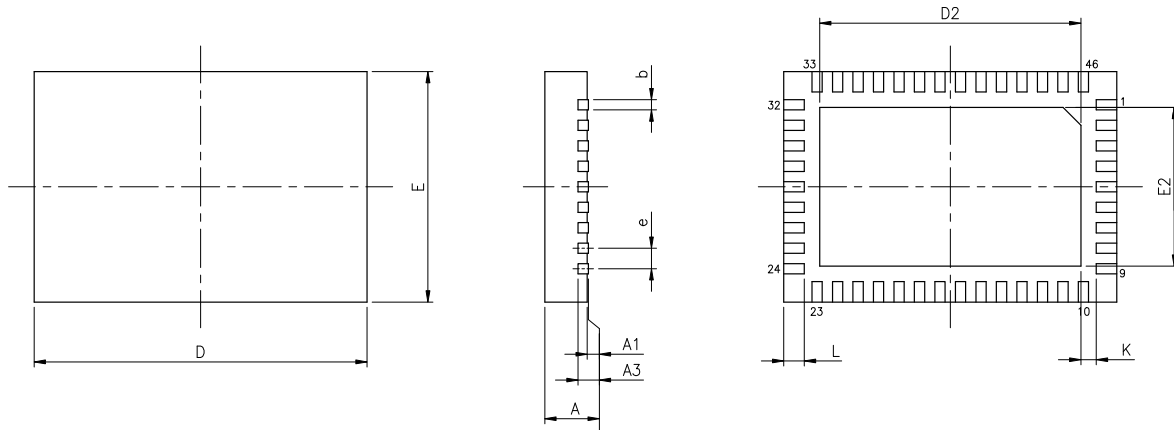

Symbol	Dimensions in inch		
	Min.	Nom.	Max.
A	0.028	0.030	0.031
A1	0.000	0.001	0.002
A3	0.008 REF		
b	0.006	0.008	0.010
D	0.256 BSC		
E	0.177 BSC		
e	0.016 BSC		
D2	0.197	—	0.205
E2	0.118	—	0.126
L	0.014	0.016	0.018
K	0.008	—	—

Symbol	Dimensions in mm		
	Min.	Nom.	Max.
A	0.70	0.75	0.80
A1	0.00	0.02	0.05
A3	0.203 REF		
b	0.15	0.20	0.25
D	6.50 BSC		
E	4.50 BSC		
e	0.40 BSC		
D2	5.00	—	5.20
E2	3.00	—	3.20
L	0.35	0.40	0.45
K	0.20	—	—

44-pin LQFP (10mm×10mm) (FP2.0mm) Outline Dimensions

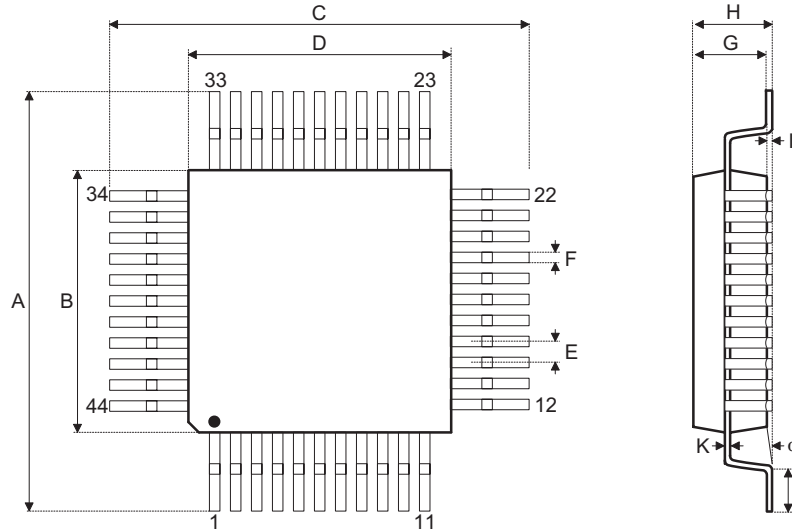

Symbol	Dimensions in inch		
	Min.	Nom.	Max.
A		0.472 BSC	
B		0.394 BSC	
C		0.472 BSC	
D		0.394 BSC	
E		0.032 BSC	
F	0.012	0.015	0.018
G	0.053	0.055	0.057
H	—	—	0.063
I	0.002	—	0.006
J	0.018	0.024	0.030
K	0.004	—	0.008
α	0°	—	7°

Symbol	Dimensions in mm		
	Min.	Nom.	Max.
A		12.00 BSC	
B		10.00 BSC	
C		12.00 BSC	
D		10.00 BSC	
E		0.80 BSC	
F	0.30	0.37	0.45
G	1.35	1.40	1.45
H	—	—	1.60
I	0.05	—	0.15
J	0.45	0.60	0.75
K	0.09	—	0.20
α	0°	—	7°

48-pin LQFP (7mm×7mm) Outline Dimensions

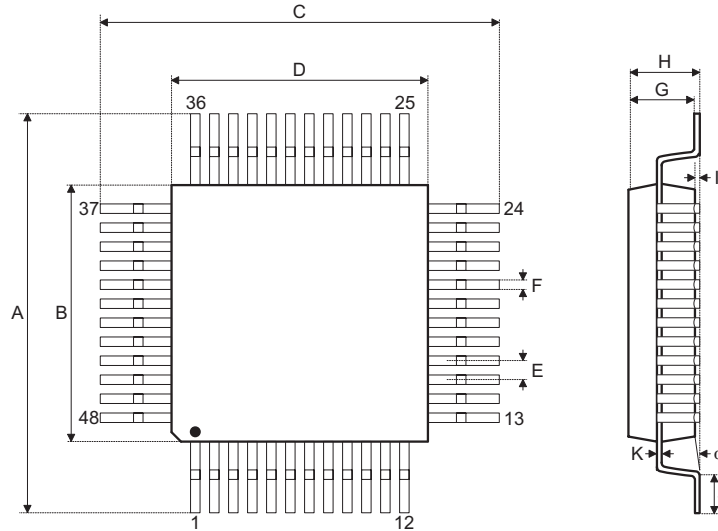

Symbol	Dimensions in inch		
	Min.	Nom.	Max.
A		0.354 BSC	
B		0.276 BSC	
C		0.354 BSC	
D		0.276 BSC	
E		0.020 BSC	
F	0.007	0.009	0.011
G	0.053	0.055	0.057
H	—	—	0.063
I	0.002	—	0.006
J	0.018	0.024	0.030
K	0.004	—	0.008
α	0°	—	7°

Symbol	Dimensions in mm		
	Min.	Nom.	Max.
A		9.00 BSC	
B		7.00 BSC	
C		9.00 BSC	
D		7.00 BSC	
E		0.50 BSC	
F	0.17	0.22	0.27
G	1.35	1.40	1.45
H	—	—	1.60
I	0.05	—	0.15
J	0.45	0.60	0.75
K	0.09	—	0.20
α	0°	—	7°

Copyright© 2024 by HOLTEK SEMICONDUCTOR INC. All Rights Reserved.

The information provided in this document has been produced with reasonable care and attention before publication, however, HOLTEK does not guarantee that the information is completely accurate. The information contained in this publication is provided for reference only and may be superseded by updates. HOLTEK disclaims any expressed, implied or statutory warranties, including but not limited to suitability for commercialization, satisfactory quality, specifications, characteristics, functions, fitness for a particular purpose, and non-infringement of any third-party's rights. HOLTEK disclaims all liability arising from the information and its application. In addition, HOLTEK does not recommend the use of HOLTEK's products where there is a risk of personal hazard due to malfunction or other reasons. HOLTEK hereby declares that it does not authorize the use of these products in life-saving, life-sustaining or safety critical components. Any use of HOLTEK's products in life-saving/sustaining or safety applications is entirely at the buyer's risk, and the buyer agrees to defend, indemnify and hold HOLTEK harmless from any damages, claims, suits, or expenses resulting from such use. The information provided in this document, including but not limited to the content, data, examples, materials, graphs, and trademarks, is the intellectual property of HOLTEK (and its licensors, where applicable) and is protected by copyright law and other intellectual property laws. No license, express or implied, to any intellectual property right, is granted by HOLTEK herein. HOLTEK reserves the right to revise the information described in the document at any time without prior notice. For the latest information, please contact us.