



Digital Pyroelectric Infrared Sensor (Model: RDA226S-F)

User's Manual

Version: 1.1

Valid from: 2021-11-04

Zhengzhou Winsen Electronics Technology Co., Ltd

Statement

This manual copyright belongs to Zhengzhou Winsen Electronics Technology Co., LTD. Without the written permission, any part of this manual shall not be copied, translated, stored in database or retrieval system, also can't spread through electronic, copying, record ways.

Thanks for purchasing our product. In order to let customers use it better and reduce the faults caused by misuse, please read the manual carefully and operate it correctly in accordance with the instructions. If users disobey the terms or remove, disassemble, change the components inside of the sensor, we shall not be responsible for the loss.

The specific such as color, appearance, sizes &etc, please in kind prevail.

We are devoting ourselves to products development and technical innovation, so we reserve the right to improve the products without notice. Please confirm it is the valid version before using this manual. At the same time, users' comments on optimized using way are welcome.

Please keep the manual properly, in order to get help if you have questions during the usage in the future.

Zhengzhou Winsen Electronics Technology CO., LTD.

RDA226S-F Digital Pyroelectric Infrared Sensor

Digital PIR sensor RDA226S-F, is an integrated design of sensitive element and signal processing chip, packaged sensitive element and IC chip into sensor shield. Sensitive element transfer the human movement signal to high-precision digital chip for data processing. Then the sensor gives digital signal for easy using.

Features:

- * High-precision AD signal process
- * Differential signal input mode, anti-interference ability
- * Sensitivity, delay time, and light adjustment function
- * Enable pin controls the sensor output
- * Wide working voltage(2.2~5V) and power consumption
- * Digital TTL signal output



Applications

Security product
 Human body induction toys
 Human body induction lamps, and switches
 Industrial automation control
 Smart home
 IOT terminals
 Intelligent appliance

Technical Parameter

Max Limit

Parameter	Symbol	Min	Max	Unit	
Power supply	V _{DD}	0.3	5.5	V	25°C
Power	V _{out}	V _{SS} -0.3	V _{DD} +0.3	V	
Storage temperature	T _{ST}	-40	125	°C	

Electrical parameter (Unless otherwise specified: T=25 °C, V_{DD} =3.0V)

Parameter	Symbol	Min	Typical	Max	Unit	Note
Working condition						
Voltage	V _{DD}	2.2	3.0	5.0	V	Power supply mode
Current	I _{DD}	8.0	10	15	uA	V _{DD} =3V, non-loaded
Temperature	TOPR	-20		+70	°C	
Output Pin(ONTIME&SENS&OEN)						
SENS ONTIME INPUT V	V _{IN}	V _{SS} -0.3		V _{DD} +0.3		
SENS ONTIME INPUT I				20	nA	Pull-down current
OEM Input Low level	V _{IL_OEN}			0.5	V	V _{DD} =3.0
OEM Input High level	V _{IH_OEN}	1.0			V	V _{DD} =3.0
Output Pin(REL)						
Max drive current	I _{REL}			10	mA	V _{DD} =5.0
REL output (high level)	V _{OH}			2.7	V	V _{DD} =3V
REL output (low level)	V _{OL}	0.3			V	I _{OH} =10mA
Block time			2.0		S	
Delay time	ON _{TIME}	2		3600	S	16 steps adjustable

						(non-linearity)
Oscillators and filters						
Low filter cut-off frequency	F_{IPF}			7	Hz	
High filter cut-off frequency	F_{HPF}	0.4			Hz	

Internal frame

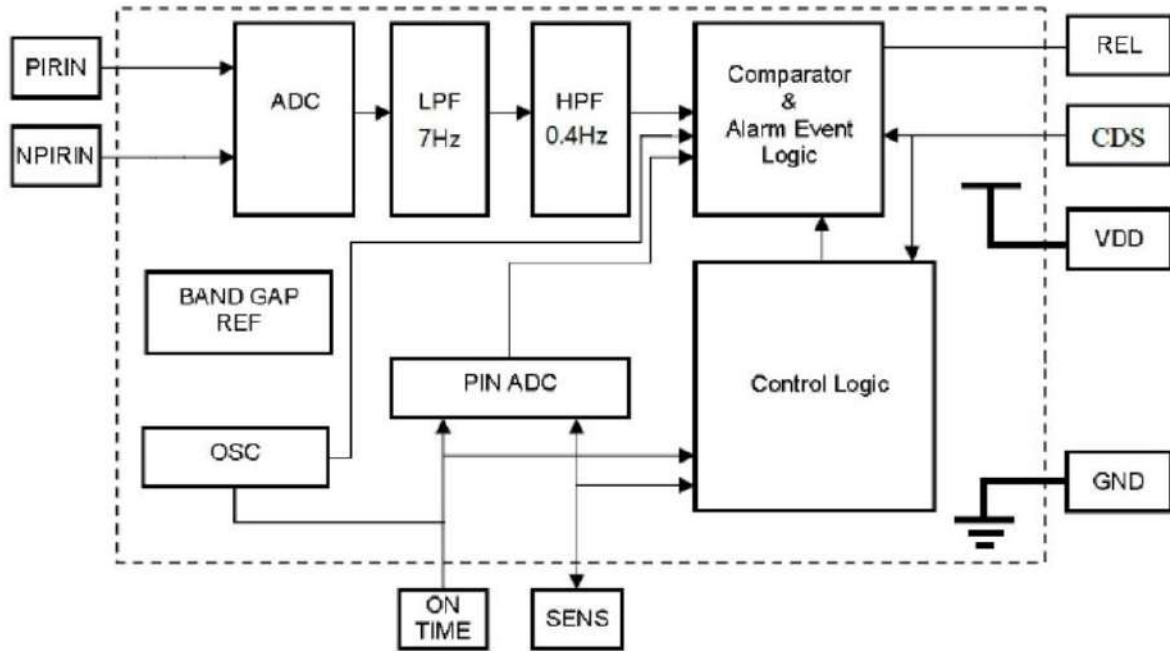

Trigger mode

CDS is the enabled pin of REL output. When CDS is in high level, REL output is enabled. When CDS is in low level, REL output is disabled. CDS pin can be connected to photosensitive resistor or photosensitive diode, to achieve the function of not working during the day, and working during night only.

In the normal detection condition, the sensor can be effectively triggered, REL pin output high level, and maintain a preset time, if the following conditions are met:

- (1) CDS is in high level
- (2) When the signal amplitude successively exceeds the positive and negative thresholds within 4S ;
- (3) The signal amplitude exceeds 5 times the threshold;

After the sensor is effectively triggered, the REL pin outputs and maintains the high level for a certain time. The time of high level output can be adjusted by the partial voltage resistor of the ONTIME pin. During the high level output period, if the effective trigger signal is detected again, the output high time is recalculated.

Remark: The sensor has warm-up time. After power on, the REL pin outputs high level for 2 seconds and low level for 2 seconds. Warm-up time has nothing to do with ONTIME

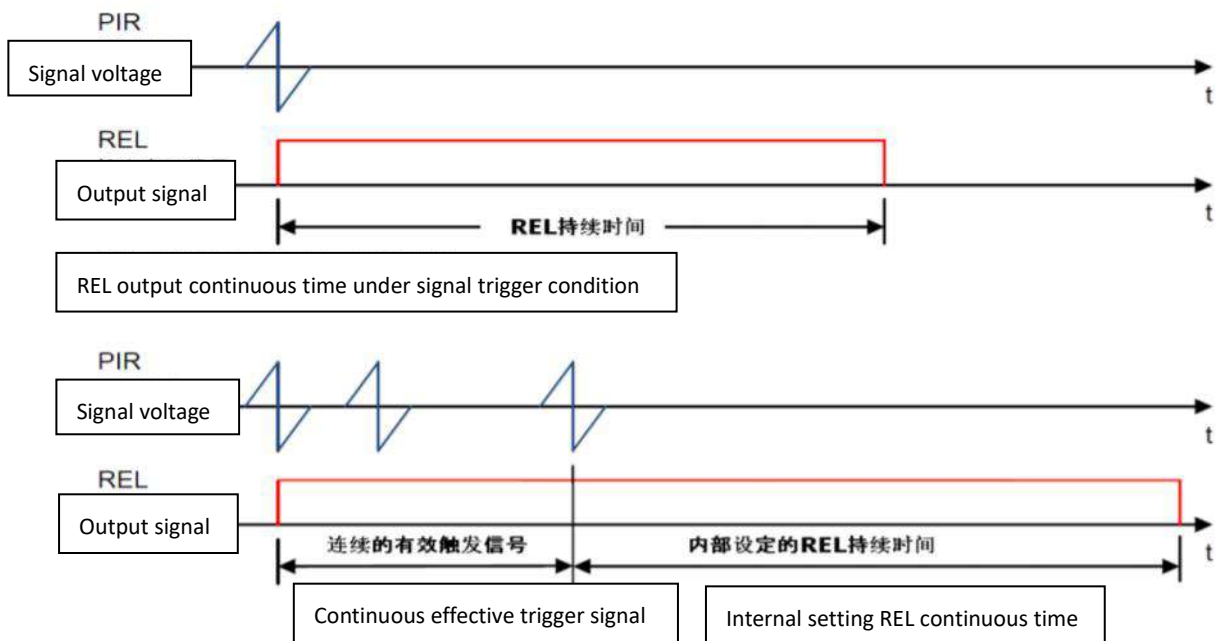

Delay time adjustment

The delay time is the high-level TTL output duration time when sensor reaches the comparison threshold. The input voltage of ONTIME pin, determines the duration of output signal. Each time the trigger signal is received, the delay time is recalculated. The relationship between output delay time and voltage, is as below for your reference. When the voltage value exceeds 1/2VDD, it would choose max delay time.

Item	Center value of Pin voltage	Duration time (Second)	Theoretical pull-down resistor(ohm)	Recommended pull-down resistor(ohm)
1	1*VDD/64	2	0K	0K
2	3*VDD/64	5	49k	51k
3	5*VDD/64	10	85k	59k
4	7*VDD/64	15	123k	130k
5	9*VDD/64	20	164k	160k
6	11*VDD/64	30	208k	220k
7	13*VDD/64	45	255k	270k
8	15*VDD/64	60	306k	330k
9	17*VDD/64	90	363k	360k
10	19*VDD/64	120	422k	430k
11	21*VDD/64	180	488k	510k
12	23*VDD/64	300	561k	560k
13	25*VDD/64	600	641k	680k
14	27*VDD/64	900	730k	750k
15	29*VDD/64	1800	829k	820k
16	31*VDD/64	3600	939k	1M

Sensitivity adjustment

The input voltage on SENS pin, determines the comparison threshold for the input signal. When connected to ground, the sensor comparison threshold is the lowest, sensitivity is highest, that is, detection distance is the farthest.

When the input voltage is over 1/2VDD, it would choose max threshold, sensitivity is the lowest, that is, the detection distance is minimal.

The sensing distance is not linear with the voltage on the SENS pin. With different Fresnel lenses, the sensitivity is different, and distance depends on actual measurement.

No.	Center value of SENS Pin voltage	Theoretical pull-down resistor(ohm)	Recommended pull-down resistor(ohm)
0	1/128	0K	0K
1	3/128	24K	24K
2	5/128	41K	43K
3	7/128	58K	56K
4	9/128	76K	75K
5	11/128	94K	91K
6	13/128	113K	110K
7	15/128	133K	130K
8	17/128	153K	150K
9	19/128	174K	180K
10	21/128	196K	200K
11	23/128	219K	220K
12	25/128	243K	240K
13	27/128	267K	270K
14	29/128	293K	300K
15	31/128	320K	330K
16	33/128	347K	360K
17	35/128	376K	390K
18	37/128	407K	430K
19	39/128	438K	430K
20	41/128	471K	470K
21	43/128	506K	510K
22	45/128	542K	560K
23	47/128	580K	560K
24	49/128	620K	630K
25	51/128	662K	680K
26	53/128	707K	680K
27	55/128	753K	750K
28	57/128	803K	820K
29	59/128	855K	820K

30	61/128	910K	910K
31	63/128	969K	1M

Sensor Detection Angle

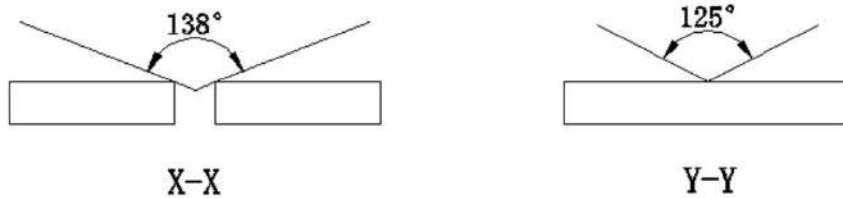

Component Structure (Unit: mm)

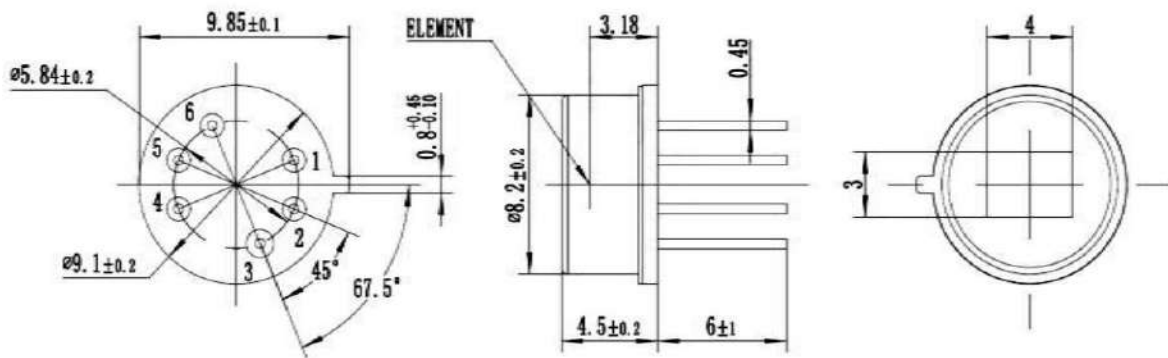

Pin Definition

Item	Name	Definition
1	SENS	Sensitivity pin (0-1/2V _{DD}); 0- highest sensitivity; ≥1/2V _{DD} - Lowest sensitivity
2	OEN	photo-cell adjustment pin. When OEN < 0.5V, trigger is prohibited; When OEN > 1.0V, trigger is allowed.
3	VSS	power ground
4	VDD	sensor power supply pin
5	REL	sensor output pin, TTL high/low level output, high valid
6	ONTime	delay time adjustment pin, 16 steps delay time selection (nonlinear). For each trigger, the delay time is recalculated.
Note		Select 0, it's recommended using a resistor to pull down to ground. Select high level, it's recommended pulling up to high level with resistor. If the photosensitive function is not used, the OEN pin should be connected to a high level.

Frequency characteristics

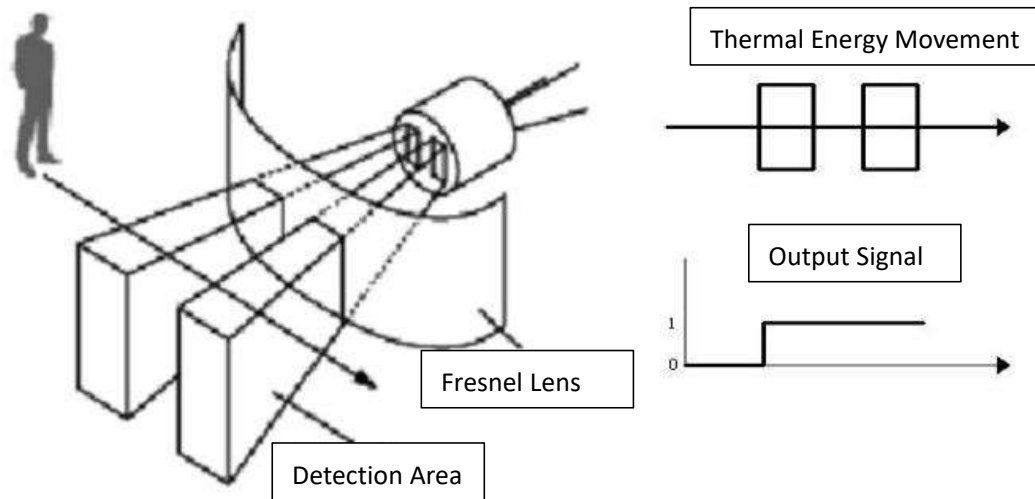

Fresnel Lens:

Fresnel Lens used, would determine the sensor's detection angle and distance, which can correspond to a variety of detection range and distance, according to customers' requirement.

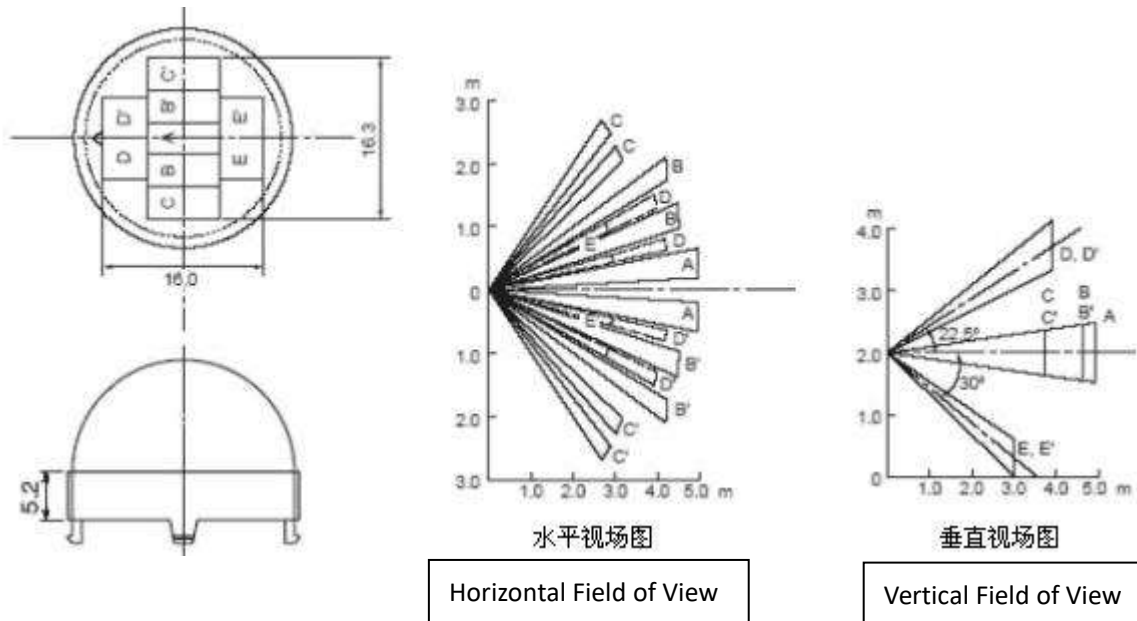

Wave Length

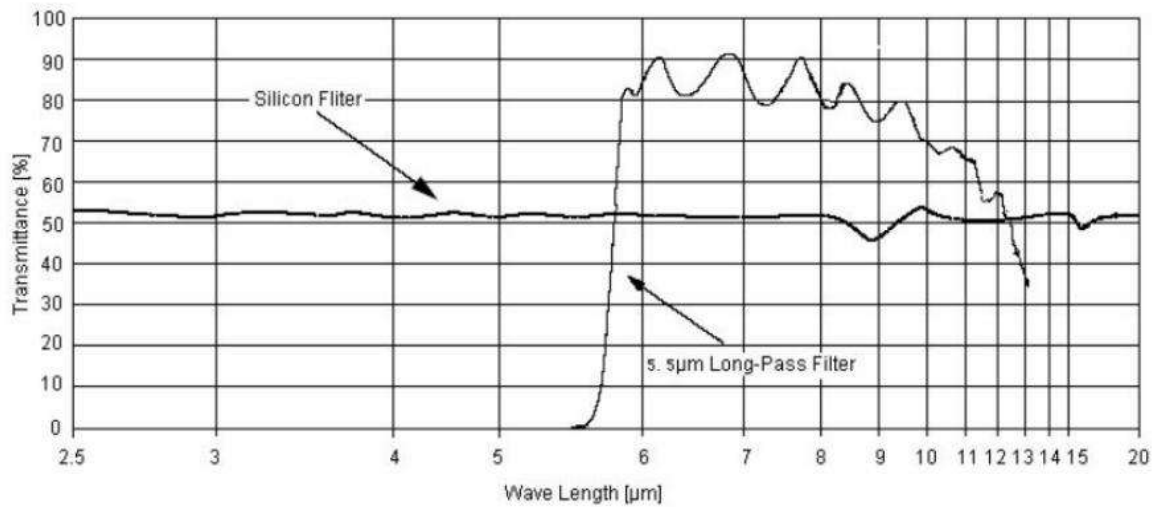

Note: The graph shows a typical 5um infrared filter reference, and the curve is the average of infrared pass rate. The window material is a special vacuum coating of semiconductor wafers.

Application

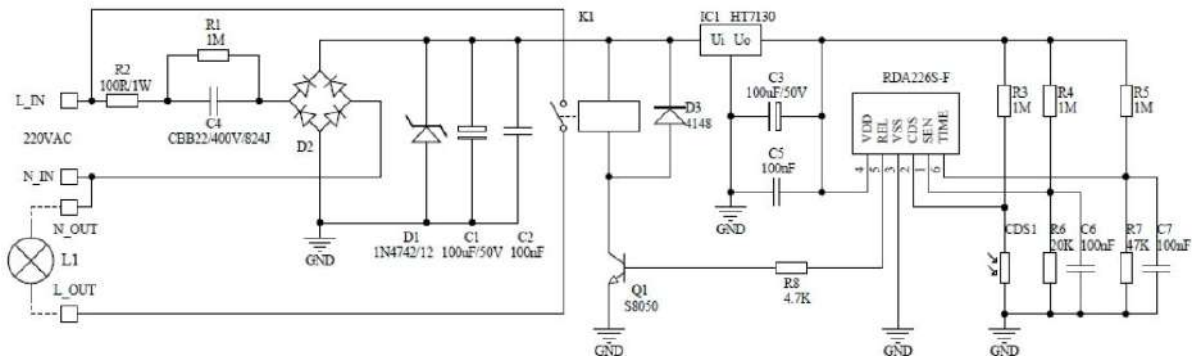

Cautions:

1. The sensor's parameter is obtained by standard testing condition after 1 minute's settling time.
2. Please pay attention on Sensor's window direction, must combine with Fresnel lens to get a perfect detecting angle.
3. Sensors detecting distance is affected by ambient temperature, moving objects' temperature, Fresnel lens, Amplifier amplification factor, the comparator threshold voltage setting...etc. please take a comprehensive consideration of various parameters when using the sensors.
4. Please do not touch the window area to avoid damaging to the optical filter.
5. Please handle the sensor with care when using it.
6. Please try to use hand soldering and make the soldering time as short as possible. Soldering temperature should be less than 300°C, and soldering time be less than 3 seconds.
7. Please get electrostatic protective measures when using this product, Electrostatic rating HBM: ± 5500V, CDM: ± 500V.

Note: To keep continual product development, we reserve the right to change design features without prior notice.

Zhengzhou Winsen Electronics Technology Co., Ltd

Add: No.299, Jinsuo Road, National Hi-Tech Zone,
Zhengzhou 450001 China

Tel: +86-371-67169097/67169670

Fax: +86-371-60932988

E-mail: sales@winsensor.com

Website: www.winsen-sensor.com