



SMBJ

TVS DIODE

SURFACE MOUNT TRANSIENT VOLTAGE SUPPRESSORS

DESCRIPTION

The UTC **SMBJ** is a surface mount transient voltage suppressors, it uses UTC's advanced technology to provide customers with low leakage and very fast response time, etc.

FEATURES

- * Low leakage
- * Very fast response time

SYMBOL

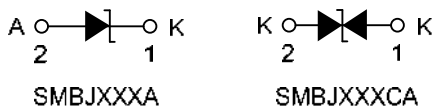

ORDERING INFORMATION

Ordering Number		Package	Pin Assignment		Packing
Lead Free	Halogen Free		1	2	
SMBJXXXAL-SMB-R	SMBJXXXAG-SMB-R	SMB	K	A	Tape Reel
SMBJXXXCAL-SMB-R	SMBJXXXCAG-SMB-R	SMB	K	K	Tape Reel

Note: Pin Assignment: K: Cathode A: Anode

<p>SMBJXXXXXG-SMB-R</p> <ul style="list-style-type: none"> (1) Packing Type (2) Package Type (3) Green Package (4) Category (5) Output Voltage Code 	<ul style="list-style-type: none"> (1) R: Tape Reel (2) SMB: SMB (3) G: Halogen Free and Lead Free, L: Lead Free (4) A: 5% uni-directional, CA: 5% Bi-directional (5) XXX: refer to ELECTRICAL CHARACTERISTICS
--	---

MARKING

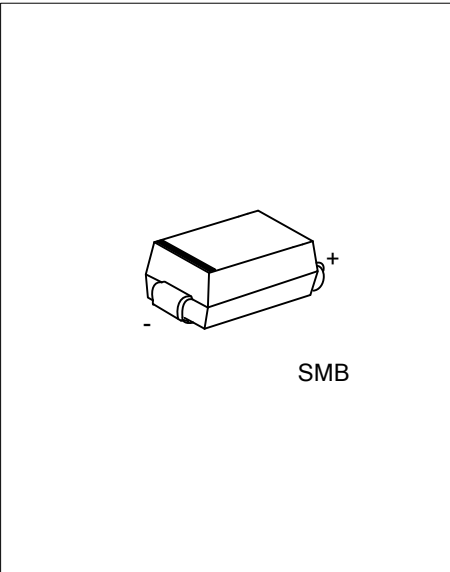
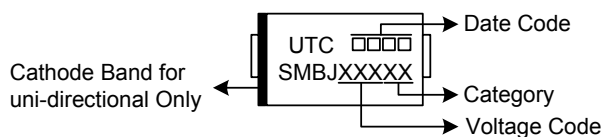

SMB

■ ABSOLUTE MAXIMUM RATING ($T_A=25^\circ\text{C}$ unless otherwise noted)

PARAMETER	SYMBOL	RATINGS	UNIT
Peak Power Dissipation with a 10/1000 μs Waveform (Note 2)	P_{PP}	600	W
Peak Pulse Current with a 10/1000 μs Waveform (Note 2)	I_{PP}	See ELECTRICAL CHARACTERISTICS Table	A
Power Dissipation On Infinite Heatsink at $T_L = 75^\circ\text{C}$	P_D	5.0	W
Peak Forward Surge Current, 8.3 ms Single Half Sine-wave Unidirectional Only (Note 3)	I_{FSM}	100	A
Maximum Instantaneous Forward Voltage at 50 A for Unidirectional Only (Note 4)	V_F	3.5	V
Operating Junction Temperature	T_J	-55 ~ +150	$^\circ\text{C}$
Storage Temperature	T_{STG}	-55 ~ +150	$^\circ\text{C}$

Notes: 1. Absolute maximum ratings are those values beyond which the device could be permanently damaged.

Absolute maximum ratings are stress ratings only and functional device operation is not implied.

2. Non-repetitive current pulse and derated above $T_A=25^\circ\text{C}$

3. Measured on 8.3ms single half sine-wave or equivalent square wave, duty cycle=4 pulses per minute maximum.

■ ELECTRICAL CHARACTERISTICS ($T_A=25^\circ\text{C}$, unless otherwise noted)

PART NUMBER (Uni)	PART NUMBER (Bi)	BREAKDOWN VOLTAGE V_{BR} @ I_T			MAXIMUM REVERSE LEAKAGE I_R @ V_{RWM} (μA)	WORKING PEAK REVERSE VOLTAGE V_{RWM} (V)	MAXIMUM REVERSE SURGE CURRENT I_{PP} (A)	MAXIMUM CLAMPING VOLTAGE V_C @ I_{PP} (V)
		MIN (V)	MAX (V)	I_T (mA)				
SMBJ5A	SMBJ5CA	6.40	7.00	10	800	5.0	65.22	9.2
SMBJ5V8A	SMBJ5V8CA	6.46	7.14	10	1000	5.8	57.14	10.5
SMBJ6A	SMBJ6CA	6.67	7.37	10	800	6.0	58.25	10.3
SMBJ6V5A	SMBJ6V5CA	7.22	7.98	10	500	6.5	53.57	11.2
SMBJ7A	SMBJ7CA	7.78	8.60	10	200	7.0	50.00	12.0
SMBJ7V5A	SMBJ7V5CA	8.33	9.21	1	100	7.5	46.51	12.9
SMBJ8A	SMBJ8CA	8.89	9.83	1	50	8.0	44.12	13.6
SMBJ8V5A	SMBJ8V5CA	9.44	10.4	1	10	8.5	41.67	14.4
SMBJ9A	SMBJ9CA	10.00	11.10	1	5	9.0	38.96	15.4
SMBJ10A	SMBJ10CA	11.10	12.30	1	5	10	35.29	17.0
SMBJ11A	SMBJ11CA	12.20	13.50	1	1	11	32.97	18.2
SMBJ12A	SMBJ12CA	13.30	14.70	1	1	12	30.15	19.9
SMBJ13A	SMBJ13CA	14.40	15.90	1	1	13	27.91	21.5
SMBJ14A	SMBJ14CA	15.60	17.20	1	1	14	25.86	23.2
SMBJ15A	SMBJ15CA	16.70	18.50	1	1	15	24.59	24.4
SMBJ16A	SMBJ16CA	17.80	19.70	1	1	16	23.08	26.0
SMBJ17A	SMBJ17CA	18.90	20.90	1	1	17	21.74	27.6
SMBJ18A	SMBJ18CA	20.00	22.10	1	1	18	20.55	29.2
SMBJ19A	SMBJ19CA	21.10	23.30	1	1	19	19.49	30.8
SMBJ20A	SMBJ20CA	22.20	24.50	1	1	20	18.52	32.4
SMBJ22A	SMBJ22CA	24.40	26.90	1	1	22	16.90	35.5
SMBJ24A	SMBJ24CA	26.70	29.50	1	1	24	15.42	43.0
SMBJ26A	SMBJ26CA	28.90	31.90	1	1	26	14.25	42.1
SMBJ28A	SMBJ28CA	31.10	34.40	1	1	28	13.22	45.4
SMBJ30A	SMBJ30CA	33.30	36.80	1	1	30	12.40	48.4
SMBJ33A	SMBJ33CA	36.70	40.60	1	1	33	11.26	53.3
SMBJ36A	SMBJ36CA	40.00	44.20	1	1	36	10.33	58.1
SMBJ40A	SMBJ40CA	44.40	49.10	1	1	40	9.30	64.5

■ ELECTRICAL CHARACTERISTICS (Cont.)

PART NUMBER (Uni)	PART NUMBER (Bi)	BREAKDOWN VOLTAGE V_{BR} @ I_T			MAXIMUM REVERSE LEAKAGE I_R @ V_{RWM} (μA)	WORKING PEAK REVERSE VOLTAGE V_{RWM} (V)	MAXIMUM REVERSE SURGE CURRENT I_{PP} (A)	MAXIMUM CLAMPING VOLTAGE V_C @ I_{PP} (V)
		MIN (V)	MAX (V)	I_T (mA)				
SMBJ43A	SMBJ43CA	47.80	52.80	1	1	43	8.65	69.4
SMBJ45A	SMBJ45CA	50.00	55.30	1	1	45	8.25	72.7
SMBJ48A	SMBJ48CA	53.30	58.90	1	1	48	7.75	77.4
SMBJ51A	SMBJ51CA	56.70	62.70	1	1	51	7.28	82.4
SMBJ54A	SMBJ54CA	60.00	66.30	1	1	54	6.89	87.1
SMBJ58A	SMBJ58CA	64.40	71.20	1	1	58	6.41	93.6
SMBJ60A	SMBJ60CA	66.70	73.70	1	1	60	6.20	96.8
SMBJ64A	SMBJ64CA	71.10	78.60	1	1	64	5.83	103.0
SMBJ70A	SMBJ70CA	77.80	86.00	1	1	70	5.31	113.0
SMBJ75A	SMBJ75CA	83.30	92.10	1	1	75	4.96	121.0
SMBJ78A	SMBJ78CA	86.70	95.80	1	1	78	4.76	126.0
SMBJ80A	SMBJ80CA	88.80	97.60	1	1	80	4.63	129.6
SMBJ85A	SMBJ85CA	94.40	104.00	1	1	85	4.38	137.0
SMBJ90A	SMBJ90CA	100.00	111.00	1	1	90	4.11	146.0
SMBJ100A	SMBJ100CA	111.00	123.00	1	1	100	3.70	162.0
SMBJ110A	SMBJ110CA	122.00	135.00	1	1	110	3.39	177.0
SMBJ120A	SMBJ120CA	133.00	147.00	1	1	120	3.11	193.0
SMBJ130A	SMBJ130CA	144.00	159.00	1	1	130	2.87	209.0
SMBJ140A	SMBJ140CA	155.00	171.00	1	1	140	2.65	226.8
SMBJ150A	SMBJ150CA	167.00	185.00	1	1	150	2.47	243.0
SMBJ160A	SMBJ160CA	178.00	197.00	1	1	160	2.32	259.0
SMBJ170A	SMBJ170CA	189.00	209.00	1	1	170	2.18	275.0
SMBJ180A	SMBJ180CA	200.00	220.00	1	1	180	2.06	291.6
SMBJ190A	SMBJ190CA	211.00	232.00	1	1	190	1.95	307.8
SMBJ200A	SMBJ200CA	246.00	272.00	1	1	200	1.69	356.0
SMBJ250A	SMBJ250CA	279.00	309.00	1	1	250	1.48	405.0
SMBJ300A	SMBJ300CA	335.00	371.00	1	1	300	1.23	486.0
SMBJ350A	SMBJ350CA	391.00	432.00	1	1	350	1.06	567.0
SMBJ400A	SMBJ400CA	447.00	494.00	1	1	400	0.93	648.0
SMBJ450A	SMBJ450CA	492.00	543.00	1	1	450	0.84	713.0

■ TYPICAL CHARACTERISTICS ($T_A=25^\circ\text{C}$, unless otherwise noted)

Fig 1. Pulse Derating Curve

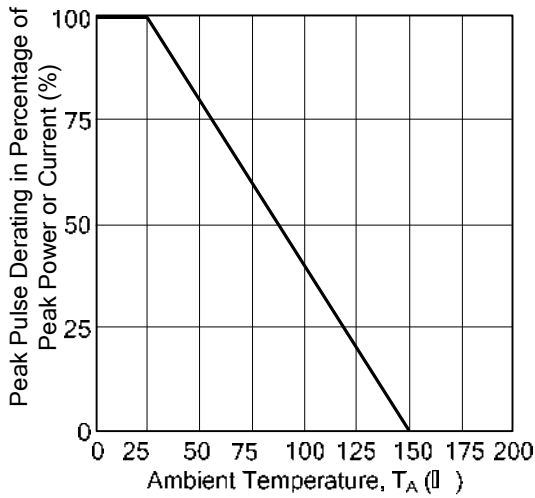

Fig 2. Maximum Non-Repetitive Surge Current

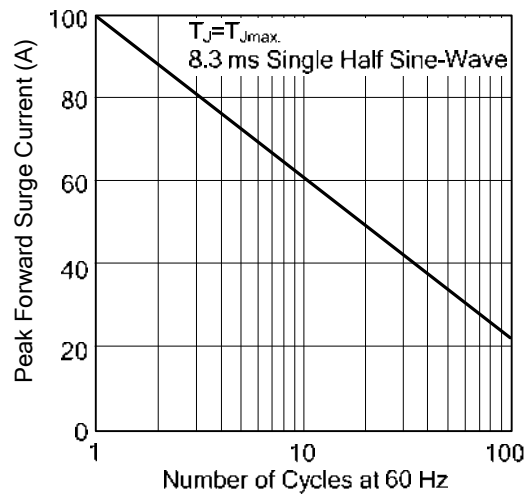

Fig 3. Steady State Power Derating Curve

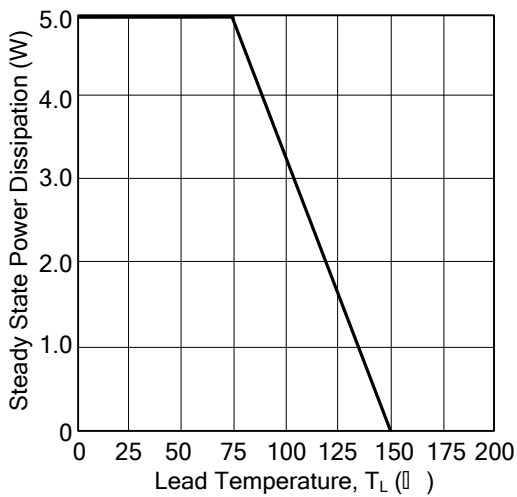

Fig 4. Peak Pulse Power Rating Curve

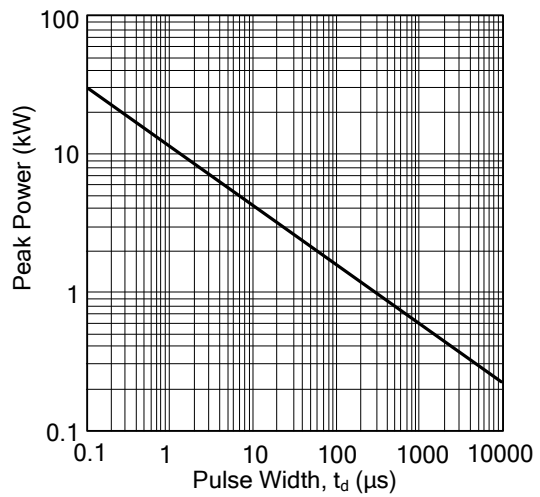

Fig 5. Pulse Waveform

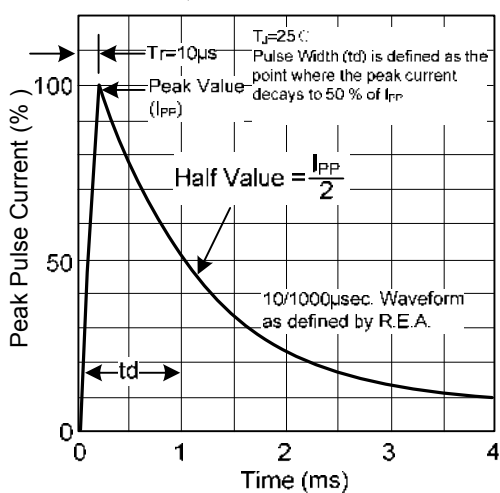
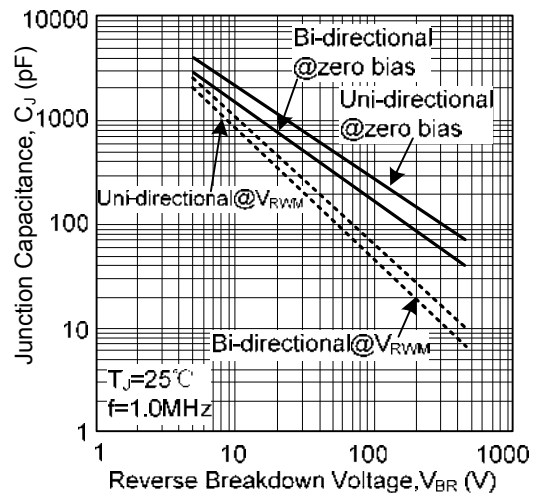

Fig 6. Typical Junction Capacitance



UTC assumes no responsibility for equipment failures that result from using products at values that exceed, even momentarily, rated values (such as maximum ratings, operating condition ranges, or other parameters) listed in products specifications of any and all UTC products described or contained herein. UTC products are not designed for use in life support appliances, devices or systems where malfunction of these products can be reasonably expected to result in personal injury. Reproduction in whole or in part is prohibited without the prior written consent of the copyright owner. UTC reserves the right to make changes to information published in this document, including without limitation specifications and product descriptions, at any time and without notice. This document supersedes and replaces all information supplied prior to the publication hereof.