

# 承认书

## SPECIFICATION

版本号 Version: A0

客户名称：\_\_\_\_\_ 客户料号：\_\_\_\_\_

Customer's Name : \_\_\_\_\_ Customer's Part No : \_\_\_\_\_

产品名称：\_\_\_\_\_ Microphone \_\_\_\_\_ 送样编号：\_\_\_\_\_

Production Name : \_\_\_\_\_ Sample No : \_\_\_\_\_

灵敏度：\_\_\_\_\_ -38±3dB \_\_\_\_\_ 公司型号：\_\_\_\_\_ EM9767P \_\_\_\_\_

Sensitivity : \_\_\_\_\_ Model : \_\_\_\_\_

CUSTOMER	CHECKER	APPROVER

如蒙承认请签名后回传，谢谢！

Please counter signed fax back to us to signify your acceptance. Thanks!

<b>Prepare</b>	忻兴忠	<b>CHECKER</b>	黄恩光	<b>APPROVER</b>	黄恩光
DATE	2016.11.29	DATE	2016.11.29	DATE	2016.11.29

1. 产品型号 Model NO.

EM9767P

## 2. 电性能 Electrical Characteristics

标准测试条件 Standard Test Condition : 温度 Temperature :15℃~35℃ 相对湿度 Rel.Humidity:45%~75%(RH) 气压/Pressure :86~106KPa

判定测试条件 Judgment Test Condition : 温度 Temperature :20℃±2℃ 相对湿度 Rel.Humidity:60%~70%(RH) 气压/ Pressure :86~106KPa

序号 NO.	参数 Parameter	符号 Symbol	条件 Condition	范围 Limits			单位 Unit
				最小值 Min.	标准值 standard	最大值 Max.	
1	尺寸 Dimension			Φ9.7×6.5(H)			mm
2	指向性 Directivity			全指向 Omni directional			
3	测试基准 test condition			4.5V 2.2KΩ			
4	灵敏度 Sensitivity	S	f=1KHZ, 0dB=1V/Pa	-41	-38	-35	dB
5	操作电压 Operating Voltage			1		10	V
6	输出阻抗 Output Impedance	ZOUT	f= 1KHZ			2.2	KΩ
7	消耗电流 Current Consumption	IDDS	Vc=4.5V , RL=2.2KΩ			500	uA
8	信噪比 Signal to Noise Ratio	S/N	f=1 KHZ , S.P.L=1Pa (A-Weighted)	58			dB
9	减电压特性 Decreasing Voltage	△S-VS	Vc=4.5V to 3.0V			-3	dB
10	最大输入声压 Max Input Sound Level					110	dB
11	环保法规 Environmental Regulations			RoHS			

We use "Pascal (Pa)" indication of sensitivity as per the recommendation of I.E.C. (International Electro technical

Commission).The Sensitivity of "Pa" will increase 20dB comparing with "ubar" indication.  
Example: -60dB (0dB=1V/ubar) =-40dB (1V/Pa)

依I.E.C. (国际电子协会) 建议, 以 "Pa" 为灵敏度标示单位比 "ubar" 灵敏度标示单位增加20dB  
例如: -60dB (0dB=1V/ubar) = -40dB (1V/Pa)

### 3. 测试电路图 Circuit Diagram

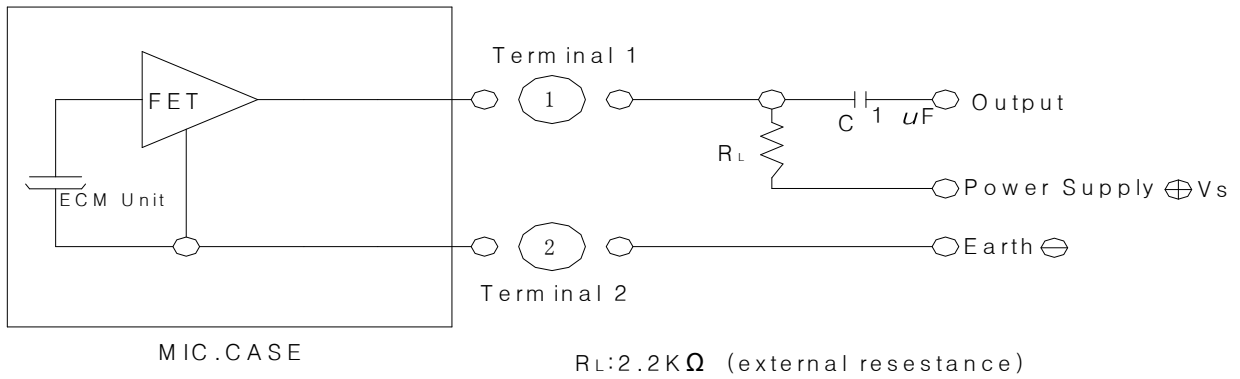

### 4. 典型频率响应曲线 Typical Frequency Response Curve (far field)

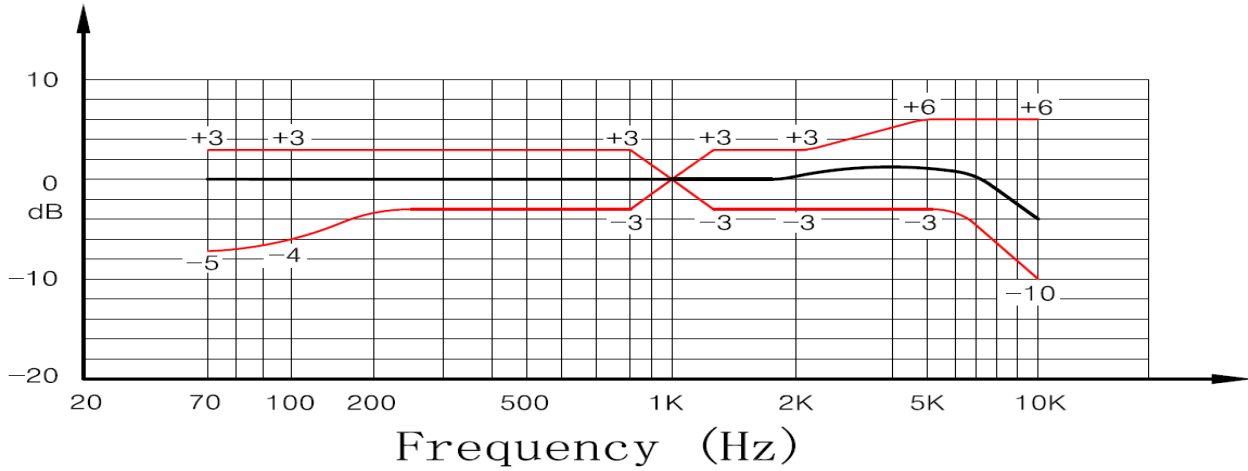

### 5. 外形图 Outside Drawing

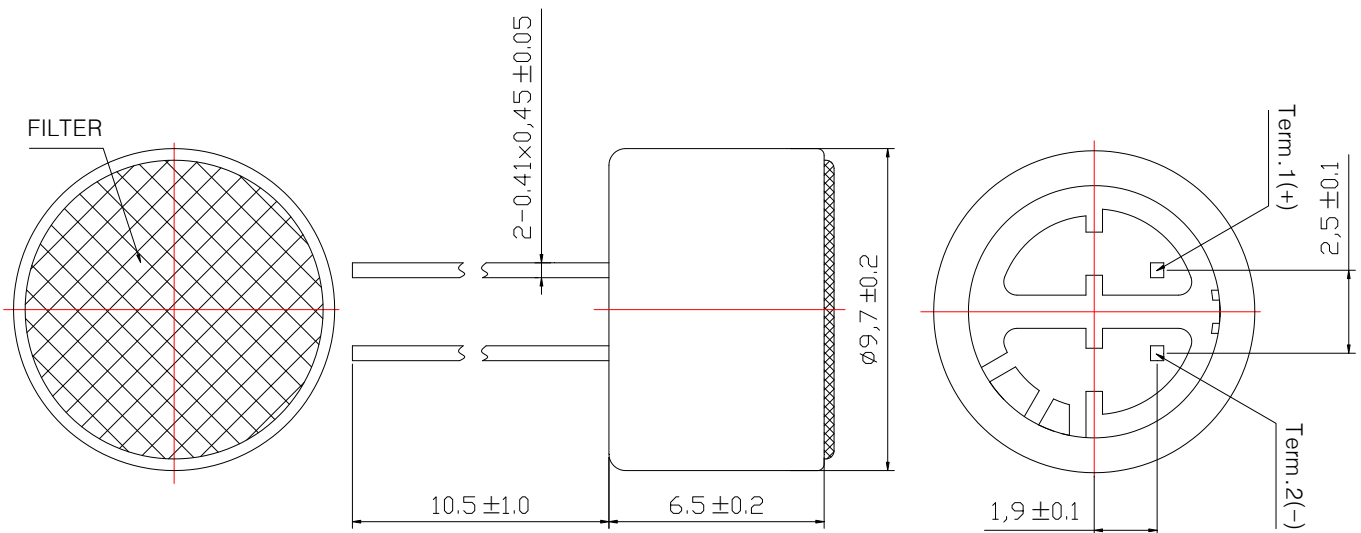

## 6. 可靠性试验 Reliability Test

经过以下所有试验在温度 15°C~35°C和湿度 45%~75% 的条件下放置 3 小时后,要求麦克风的灵敏度试验前后变化在 3dB 以内

After any following tests, the sensitivity of the microphone to be within  $\pm 3\text{dB}$  of initial sensitivity after 3 hours of conditioning at 15°C~35°C and 45%~75% RH

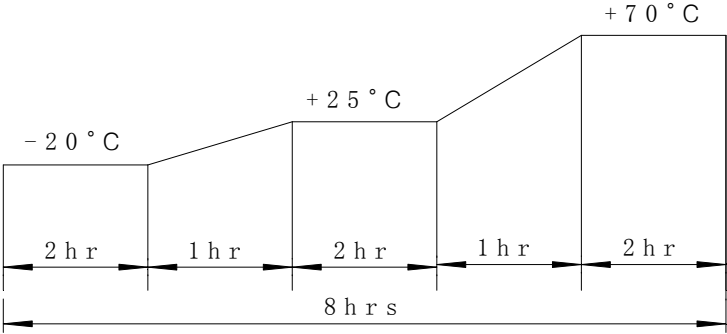
<p>6.1 振动试验 Vibration Test</p>	<p>1 分钟频率变化从 10Hz 到 55Hz, 振幅 1.52mm, 在三个方向各振动 2 小时 1 minute frequency from 10Hz to 55Hz, amplitude 1.52mm, the vibration in three directions 2 hours</p>
<p>6.2 跌落试验 Drop Test</p>	<p>分别把包装的三个面从 1 米高处自由落到地面上, 各 10 次 Three faces of package from 1 meters high free fall to the ground, each 10 times</p>
<p>6.3 高温试验 Dry Heat Test</p>	<p>在 70°C<math>\pm</math>3°C环境中维持 96 小时 70°C<math>\pm</math>3°C for 96 hours</p>
<p>6.4 低温试验 Dry Cold</p>	<p>在-40°C<math>\pm</math>3°C环境中维持 96 小时 -40°C<math>\pm</math>3°C for 96 hours</p>
<p>6.5 高温高湿试验 Damp Heat Test</p>	<p>在温度 45°C<math>\pm</math>3°C和相对湿度 90%~95%的环境下维持 96 小时 45°C<math>\pm</math>3°C and 90%~95% RH for 96 hours</p>
<p>6.6 温度循环试验 Temperature Cycles Test</p>	<p>按如图温度和时间循环 10 次 According to the figure of temperature and time cycle, each 10 times</p>  <p>The diagram illustrates a temperature cycle with the following segments: a 2-hour hold at -20°C, a 1-hour ramp to +25°C, a 2-hour hold at +25°C, a 1-hour ramp to +70°C, and a 2-hour hold at +70°C. The total duration of one cycle is 8 hours.</p>
<p>6.7 温度冲击试验 Temperature Impact Test</p>	<p>在-20°C<math>\pm</math>3°C环境中放置 30 分钟, 然后在 70°C<math>\pm</math>3°C环境中放置 30 分钟, 这样循环 10 次。 -20°C<math>\pm</math>3°C for 30 minutes, and then 70°C<math>\pm</math>3°C for 30 minutes, each 10 times</p>

## 7 储存环境 Storage environment

<p>7.1 贮存温度/湿度 Storage Temperature/Humidity :</p>	<p>-40°C ~ +70°C / 35%~85% RH</p>
<p>7.2 工作温度/湿度 Operating Temperature/Humidity :</p>	<p>-30°C ~ +65°C / 35%~85% RH</p>

## 8. 测量系统 Measuring System

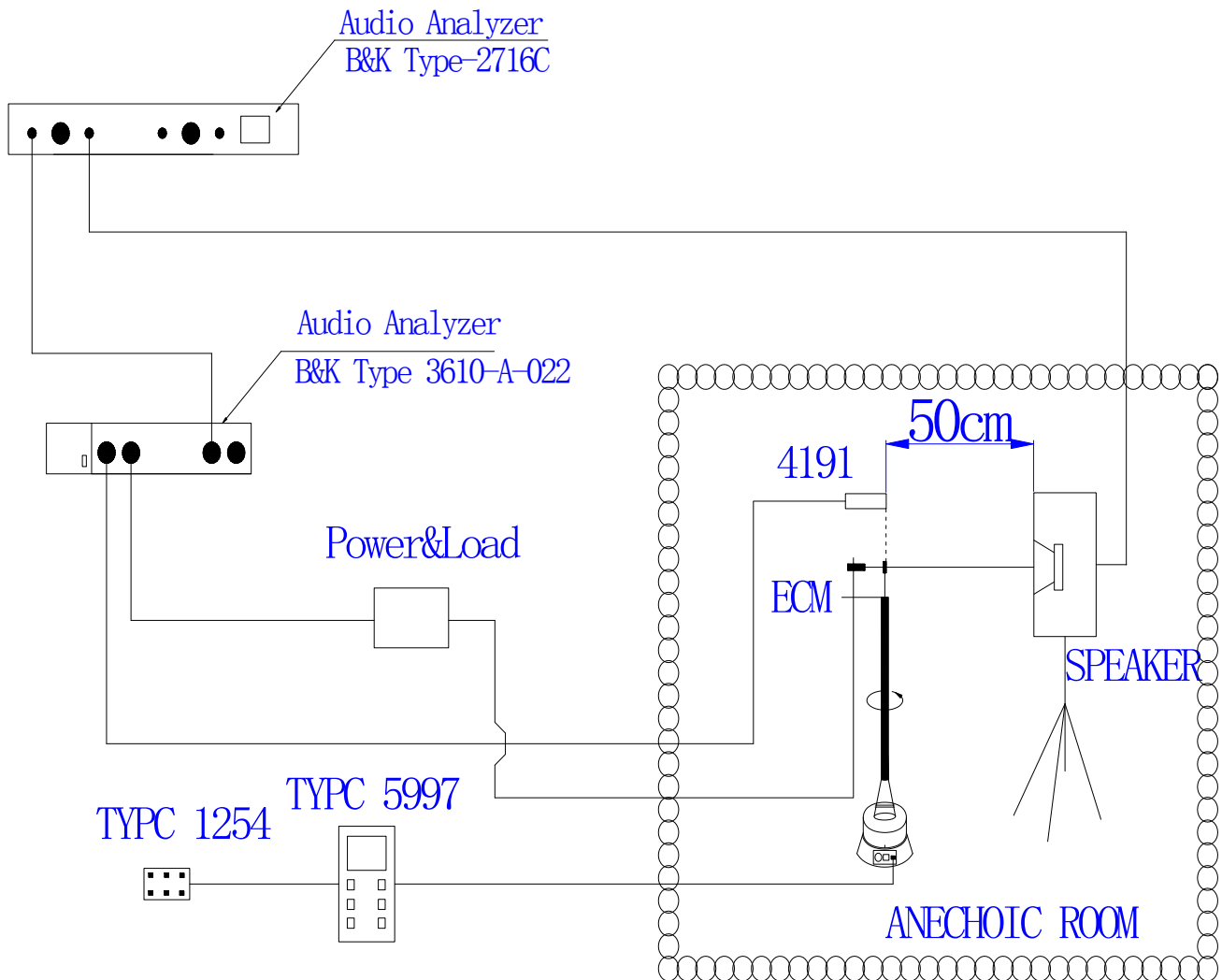

## 9. 焊接条件 Soldering Condition

9.1 焊接使用 90W 的电烙铁，表面温度应控制在  $350^{\circ}\text{C} \pm 20^{\circ}\text{C}$  范围

The soldering copper of a type of 90W shall be applied, The temperature of the working surface of the soldering copper shall be  $350 \pm 20^{\circ}\text{C}$

9.2 焊接时间应控制在 2 秒内

Welding time is within 2 seconds

9.3 应把麦克风嵌入散热能力强的金属块内进行焊接

ECM shall be soldered fixed on the metal block(heat sink)which has the higher radiation effects said heat sink

9.4 焊接后不能出现针孔

The pinhole after soldering shall be avoided

9.5 麦克风容易受静电破坏，必须采取措施避免（电烙铁和工作台应接地，戴静电环等）

ECM may easily destroyed by the static electricity and the countermeasure for eliminating the static electricity (the ground for soldering copper, for worktable and for human body) shall be executed

9.6 散热板形状 Shape of heat sink



10. 包装图 Packing diagram

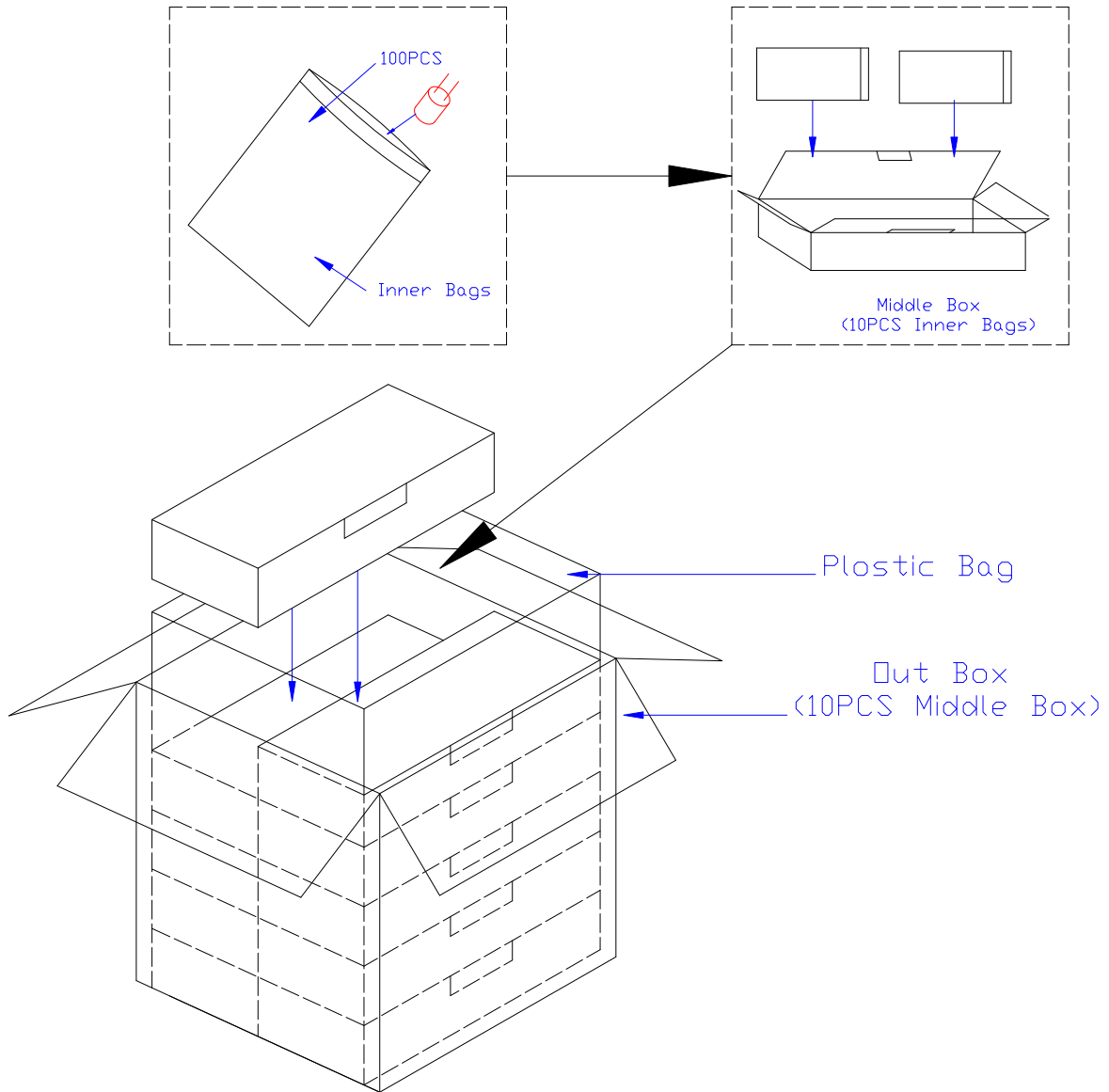

Inner Bags	136mm×90mm	100PCS×1=100PCS
Middle Box	215mm×105mm×60mm	100PCS×10=1000PCS
Out Box	230mm×230mm×320mm	1000PCS×10=10000PCS