

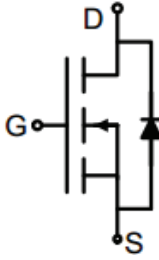

30VDS/ ±12VGS/5.8A(ID)	Part No	CM3400
------------------------	---------	--------

<p><b>Description</b> The NCE3400 uses advanced trench technology to provide excellent RDS(ON), low gate charge and operation with gate voltages as low as 2.5V. This device is suitable for use as a Battery protection or in other Switching application.</p> <p><b>Application</b></p> <ul style="list-style-type: none"> <li>•PWM applications</li> <li>•Load switch</li> <li>•Power management</li> </ul>	<p><b>Product Summary</b> VDS=30V ID= 5.8A RDS(ON)&lt; 59mΩ@ VGS=2.5V RDS(ON)&lt; 45mΩ@ VGS=4.5V RDS(ON)&lt; 41mΩ@ VGS=10V</p>	
--	--	--

 <p>SOT-23 Package</p>		
--	--	--

**Absolute Maximum Ratings (TA=25°C unless otherwise noted)**

Parameter	Symbol	Maximum	Units
Drain-Source Voltage	VDS	30	V
Gate-Source Voltage	VGS	±12	V
Continuous Current Drain	ID	5.8	A
Pulsed Drain Current(Note 1)	IDM	30	A
Power Description	PD	1.4	W
Operating Junction and Storage Temperature Range	Tj, TSTG	-55°C to 150°.	°C



Electrical Characteristics (TA=25°C unless otherwise noted)						
Symbol	Parameter	Test Conditions	Min	Type	Max	Units
<b>Off Characteristics</b>						
BVDSS	Drain-Source Breakdown Voltage	VGS = 0V, ID=-250μA	30	33	-	V
Idss	Drain-to-Source Leakage Current	VDS=-24V, VGS=0V			1	μA
Igss	Gate-Body Leakage Current	VGS=±12V, VDS=0V	-	-	±100	nA
<b>On Characteristics (Note 3)</b>						
Gate Threshold Voltage	VGS(th)	VDS=VGS, ID=250μA	0.7	0.9	1.4	V
Drain-Source On-State Resistance	RDS(O N)	VGS=2.5V, ID=4A	-	45	59	mΩ
		VGS=4.5V, ID=2.9A	-	31	45	
		VGS=10V, ID=2.9A		28	41	
Forward Trans conductance	gFS	VDS=5V, ID=2.9A	-	10	-	S
<b>Dynamic Characteristics (Note4)</b>						
Input Capacitance	Ciss	VDS=15V, VGS=0V, F=1.0MHz	-	623	-	PF
Output Capacitance	Coss		-	99	-	PF
Reverse Transfer Capacitance	Crss		-	77	-	PF
<b>Switching Characteristics (Note 4)</b>						
Turn-on Delay Time	td(on)	VDD=15V, ID=2.9A	-	3.3	-	nS
Turn-on Rise Time	tr		-	4.8	-	nS
Turn-Off Delay Time	td(off)	VGS=10V, RGEN=3Ω	-	26	-	nS
Turn-Off Fall Time	td(off)		-	4	-	nS
Total Gate Charge	Qg	VDS=15V, ID=5.8A, VGS=4.5V	-	9.5	-	nC
Gate-Source Charge	Qgs		-	1.5	-	nC
Gate-Drain Charge	Qgd		-	3	-	nC
<b>Drain-Source Diode Characteristics</b>						
Diode Forward Current (Note 2)			-	-	2.9	A
Diode Forward Voltage (Note 3)	VSD	VGS=0V, IS=2.9A	-	0.75	-1.2	v

## Notes:

1. Repetitive Rating: Pulse width limited by maximum junction temperature.
2. Surface Mounted on FR4 Board, t ≤10 sec.
3. Pulse Test: Pulse Width ≤300μs, Duty Cycle ≤2%.
4. Guaranteed by design, not subject to production



Typical Electrical and Thermal Characteristics

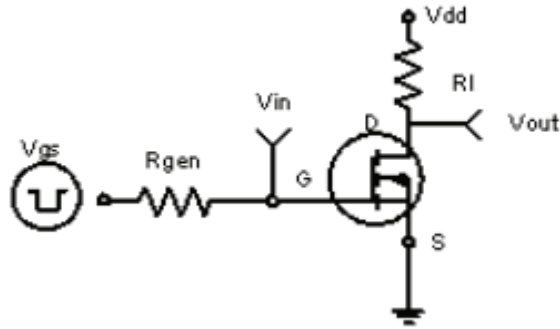

Figure 1: Switching Test Circuit

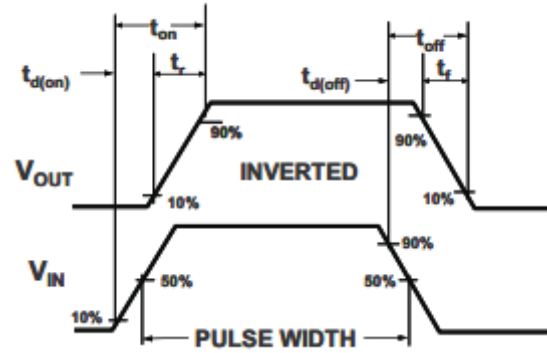

Figure 2: Switching Waveforms