



4N65

Power MOSFET

4.0A, 650V N-CHANNEL POWER MOSFET

DESCRIPTION

The UTC **4N65** is a high voltage power MOSFET designed to have better characteristics, such as fast switching time, low gate charge, low on-state resistance and have a high rugged avalanche characteristic. This power MOSFET is usually used in high speed switching applications including power supplies, PWM motor controls, high efficient AC to DC converters and bridge circuits.

FEATURES

- * $R_{DS(ON)} \leq 2.5 \Omega @ V_{GS}=10V, I_D=2.2A$
- * Fast Switching Capability
- * Avalanche Energy Specified
- * Improved dv/dt Capability, High Ruggedness

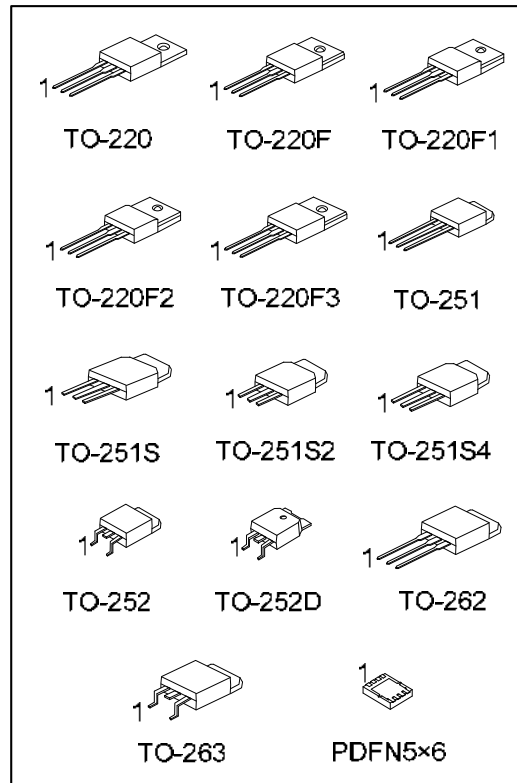

SYMBOL

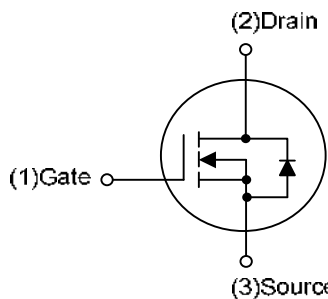

TO-220/TO-220F/TO-220F1
 TO-220F2/TO-220F3/TO-251
 TO-251S/TO-251S2/TO-251S4
 TO-252/TO-252D/TO-262/TO-263

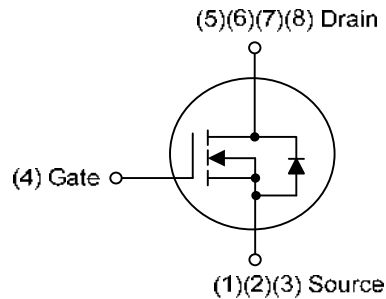

PDFN5x6

ORDERING INFORMATION

Ordering Number		Package	Pin Assignment								Packing
Lead Free	Halogen Free		1	2	3	4	5	6	7	8	
4N65L-TA3-T	4N65G-TA3-T	TO-220	G	D	S	-	-	-	-	-	Tube
4N65L-TF1-T	4N65G-TF1-T	TO-220F1	G	D	S	-	-	-	-	-	Tube
4N65L-TF2-T	4N65G-TF2-T	TO-220F2	G	D	S	-	-	-	-	-	Tube
4N65L-TF3-T	4N65G-TF3-T	TO-220F	G	D	S	-	-	-	-	-	Tube
4N65L-TF3T-T	4N65G-TF3T-T	TO-220F3	G	D	S	-	-	-	-	-	Tube
4N65L-TM3-T	4N65G-TM3-T	TO-251	G	D	S	-	-	-	-	-	Tube
4N65L-TMS-T	4N65G-TMS-T	TO-251S	G	D	S	-	-	-	-	-	Tube
4N65L-TMS2-T	4N65G-TMS2-T	TO-251S2	G	D	S	-	-	-	-	-	Tube
4N65L-TMS4-T	4N65G-TMS4-T	TO-251S4	G	D	S	-	-	-	-	-	Tube
4N65L-TN3-R	4N65G-TN3-R	TO-252	G	D	S	-	-	-	-	-	Tape Reel
4N65L-TND-R	4N65G-TND-R	TO-252D	G	D	S	-	-	-	-	-	Tape Reel
4N65L-T2Q-T	4N65G-T2Q-T	TO-262	G	D	S	-	-	-	-	-	Tube
4N65L-TQ2-T	4N65G-TQ2-T	TO-263	G	D	S	-	-	-	-	-	Tube
4N65L-TQ2-R	4N65G-TQ2-R	TO-263	G	D	S	-	-	-	-	-	Tape Reel
4N65L-P5060-R	4N65G-P5060-R	PDFN5×6	S	S	S	G	D	D	D	D	Tape Reel

Note: Pin Assignment: G: Gate D: Drain S: Source

<p>4N65G-TA3-T</p> <p>(1) Packing Type</p> <p>(2) Package Type</p> <p>(3) Green Package</p>	<p>(1) T: Tube, R: Tape Reel</p> <p>(2) TA3: TO-220, TF1: TO-220F1, TF2: TO-220F2, TF3: TO-220F, TF3T: TO-220F3, TM3: TO-251, TMS: TO-251S, TMS2: TO-251S2, TN3: TO-252, TMS4: TO-251S4, TND: TO-252D, T2Q: TO-262, TQ2: TO-263, P5060: PDFN5×6</p> <p>(3) G: Halogen Free and Lead Free, L: Lead Free</p>
---	--

MARKING

PACKAGE	MARKING
TO-220 TO-220F TO-220F1 TO-220F2 TO-220F3 TO-251 TO-251S TO-251S2 TO-251S4 TO-252 TO-252D TO-262 TO-263	<p>UTC 4N65</p> <p>Lot Code ← [] [] [] [] [] → Date Code</p> <p>1</p> <p>L: Lead Free G: Halogen Free</p>
PDFN5×6	<p>UTC 4N65</p> <p>Lot Code ← [] [] [] [] [] → Date Code</p>

■ ABSOLUTE MAXIMUM RATINGS ($T_C = 25^\circ\text{C}$, unless otherwise specified)

PARAMETER		SYMBOL	RATINGS	UNIT
Drain-Source Voltage		V_{DSS}	650	V
Gate-Source Voltage		V_{GSS}	± 30	V
Avalanche Current (Note2)		I_{AR}	4.4	A
Drain Current	Continuous	I_D	4.0	A
	Pulsed (Note2)	I_{DM}	16	A
Avalanche Energy	Single Pulsed (Note3)	E_{AS}	260	mJ
	Repetitive (Note2)	E_{AR}	10.6	mJ
Peak Diode Recovery dv/dt (Note4)		dv/dt	4.5	V/ns
Power Dissipation	TO-220/TO-262/TO-263	P_D	106	W
	TO-220F/TO-220F1 TO-220F3		35	W
	TO-220F2		36	W
	TO-251/ TO-251S TO-251S2/TO-251S4 TO-252/TO-252D		50	W
	PDFN5×6		30	W
	Junction Temperature		T_J	+150
Operating Temperature		T_{OPR}	-55 ~ +150	$^\circ\text{C}$
Storage Temperature		T_{STG}	-55 ~ +150	$^\circ\text{C}$

Note: 1. Absolute maximum ratings are those values beyond which the device could be permanently damaged.

Absolute maximum ratings are stress ratings only and functional device operation is not implied.

2. Repetitive Rating: Pulse width limited by maximum junction temperature.

3. $L = 30\text{mH}$, $I_{AS} = 4\text{A}$, $V_{DD} = 50\text{V}$, $R_G = 25\ \Omega$, Starting $T_J = 25^\circ\text{C}$

4. $I_{SD} \leq 4.4\text{A}$, $di/dt \leq 200\text{A}/\mu\text{s}$, $V_{DD} \leq BV_{DSS}$, Starting $T_J = 25^\circ\text{C}$

■ THERMAL DATA

PARAMETER	PACKAGE	SYMBOL	RATINGS	UNIT
Junction to Ambient	TO-220/TO-262/TO-263 TO-220F/TO-220F1 TO-220F2/TO-220F3	θ_{JA}	62.5	$^\circ\text{C}/\text{W}$
	TO-251/ TO-251S TO-251S2/TO-251S4 TO-252/TO-252D		110	$^\circ\text{C}/\text{W}$
	PDFN5×6		75	$^\circ\text{C}/\text{W}$
	TO-220/TO-262/TO-263		1.18	$^\circ\text{C}/\text{W}$
Junction to Case	TO-220F/TO-220F1 TO-220F3	θ_{JC}	3.5	$^\circ\text{C}/\text{W}$
	TO-220F2		3.4	$^\circ\text{C}/\text{W}$
	TO-251/ TO-251S TO-251S2/TO-251S4 TO-252/TO-252D		2.5	$^\circ\text{C}/\text{W}$
	PDFN5×6		4.17	$^\circ\text{C}/\text{W}$

■ ELECTRICAL CHARACTERISTICS (T_C=25°C, unless otherwise specified)

PARAMETER	SYMBOL	TEST CONDITIONS	MIN	TYP	MAX	UNIT	
OFF CHARACTERISTICS							
Drain-Source Breakdown Voltage	BV _{DSS}	V _{GS} = 0 V, I _D = 250μA	650			V	
Drain-Source Leakage Current	I _{DSS}	V _{DS} = 650 V, V _{GS} = 0 V			10	μA	
		V _{DS} = 480 V, T _C = 125°C			100	μA	
Gate-Source Leakage Current	I _{GSS}	V _{GS} = 30 V, V _{DS} = 0 V			100	nA	
		V _{GS} = -30 V, V _{DS} = 0 V			-100	nA	
Breakdown Voltage Temperature Coefficient	ΔBV _{DSS} /ΔT _J	I _D =250μA, Referenced to 25°C		0.6		V/°C	
ON CHARACTERISTICS							
Gate Threshold Voltage	V _{GS(TH)}	V _{DS} = V _{GS} , I _D = 250μA	2.0		4.0	V	
Static Drain-Source On-State Resistance	R _{DS(ON)}	V _{GS} = 10 V, I _D = 2.2A		2.4	2.5	Ω	
DYNAMIC CHARACTERISTICS							
Input Capacitance	C _{ISS}	V _{DS} = 25 V, V _{GS} = 0V, f = 1MHz		670	750	pF	
Output Capacitance	C _{OSS}				70	90	pF
Reverse Transfer Capacitance	C _{RSS}				23	26	pF
SWITCHING CHARACTERISTICS							
Total Gate Charge	Q _G	V _{DS} = 520V, I _D = 4.0A, V _{GS} = 10V (Note 1, 2)		100	120	nC	
Gate-Source Charge	Q _{GS}				17	19	nC
Gate-Drain Charge	Q _{GD}				20	26	nC
Turn-On Delay Time	t _{D(ON)}	V _{DS} = 325V, I _D = 4.0A, R _G = 25Ω (Note 1, 2)		45	85	ns	
Turn-On Rise Time	t _R				100	140	ns
Turn-Off Delay Time	t _{D(OFF)}				200	240	ns
Turn-Off Fall Time	t _F				130	150	ns
SOURCE- DRAIN DIODE RATINGS AND CHARACTERISTICS							
Maximum Continuous Drain-Source Diode Forward Current	I _S				4.4	A	
Maximum Pulsed Drain-Source Diode Forward Current	I _{SM}				17.6	A	
Drain-Source Diode Forward Voltage	V _{SD}	V _{GS} = 0 V, I _S = 4.4A			1.4	V	
Reverse Recovery Time	t _{rr}	V _{GS} = 0V, I _S = 4.4A,		250		ns	
Reverse Recovery Charge	Q _{rr}	di _F /dt = 100 A/μs (Note 1)		1.5		μC	

Note: 1. Pulse Test: Pulse width ≤ 300μs, Duty cycle ≤ 2%.

2. Essentially independent of operating temperature.

■ TEST CIRCUITS AND WAVEFORMS

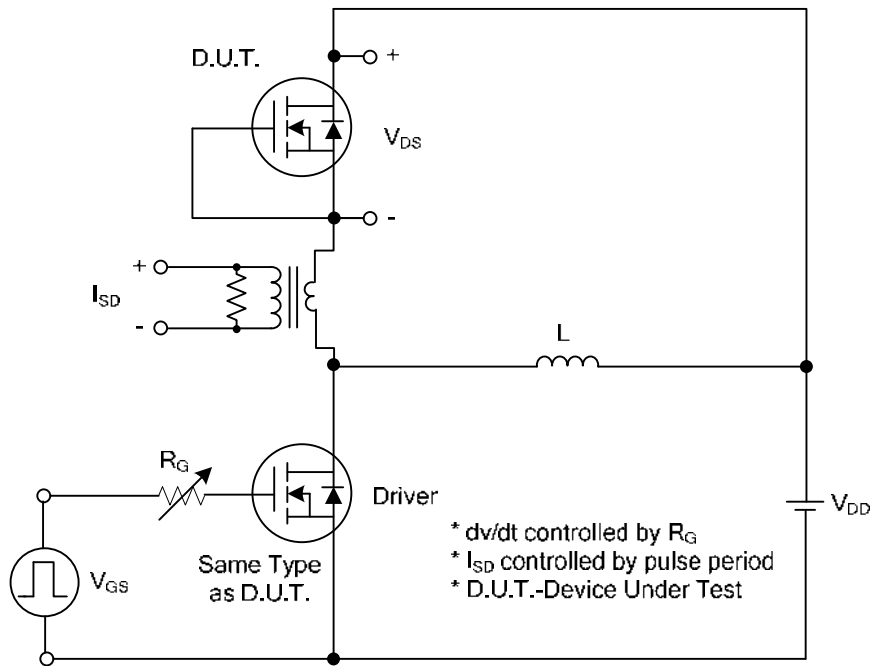

Peak Diode Recovery dv/dt Test Circuit

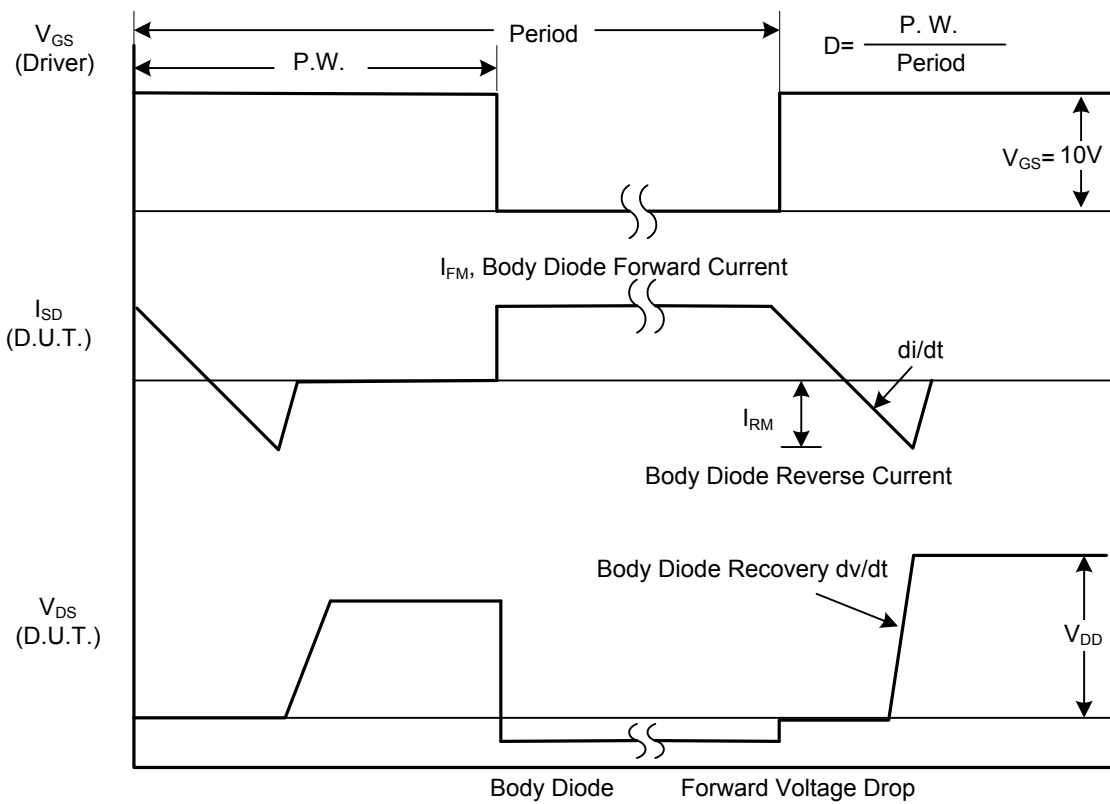

Peak Diode Recovery dv/dt Waveforms

TEST CIRCUITS AND WAVEFORMS

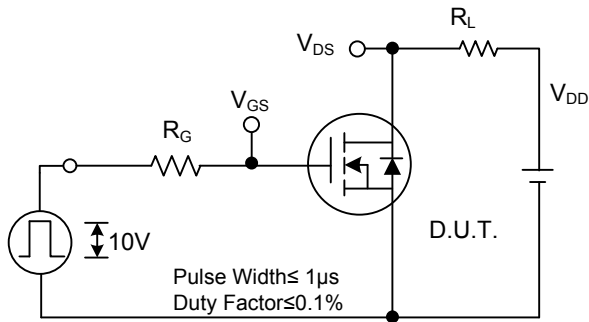

Switching Test Circuit

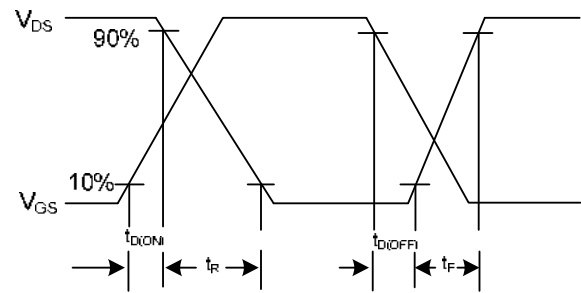

Switching Waveforms

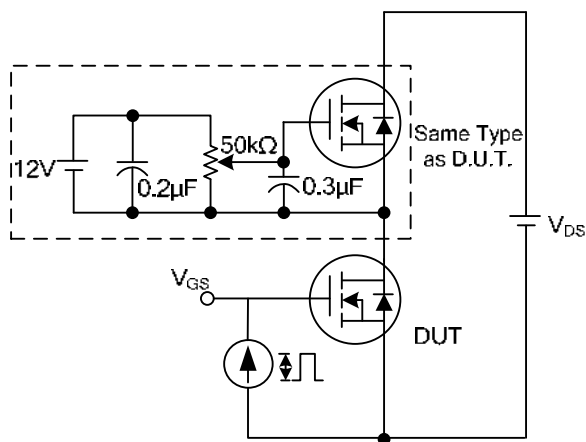

Gate Charge Test Circuit

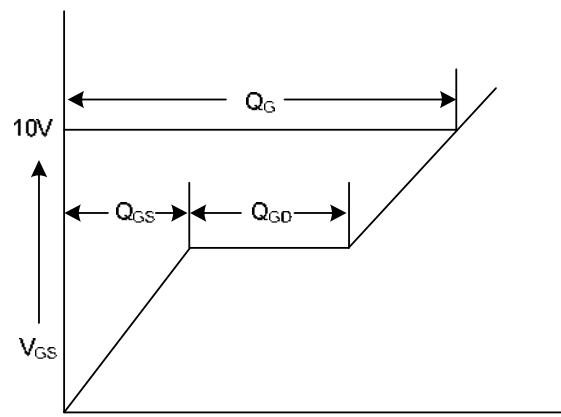

Gate Charge Waveform

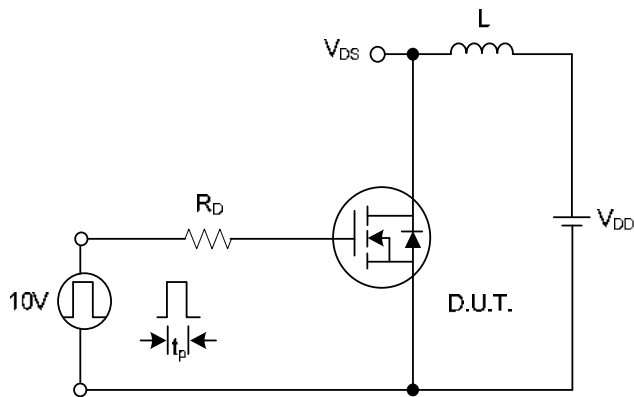

Unclamped Inductive Switching Test Circuit

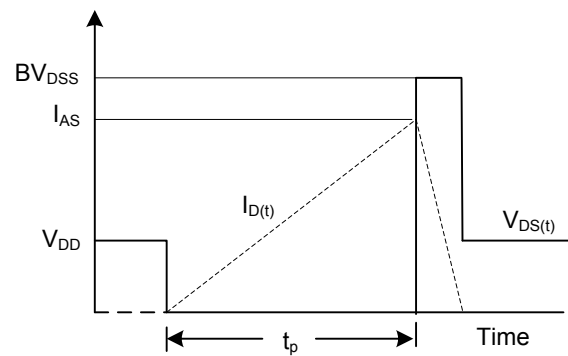

Unclamped Inductive Switching Waveforms

TYPICAL CHARACTERISTICS

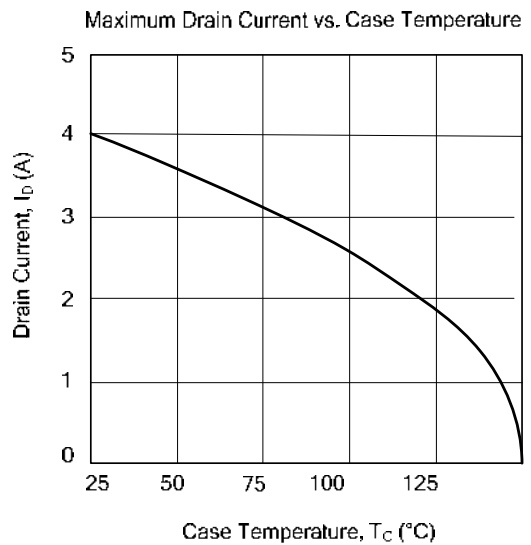
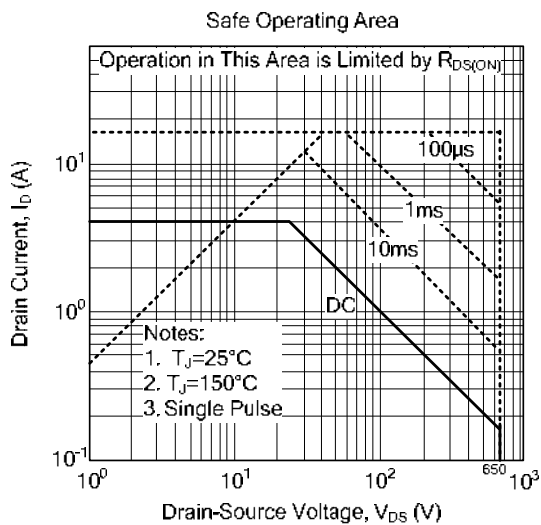
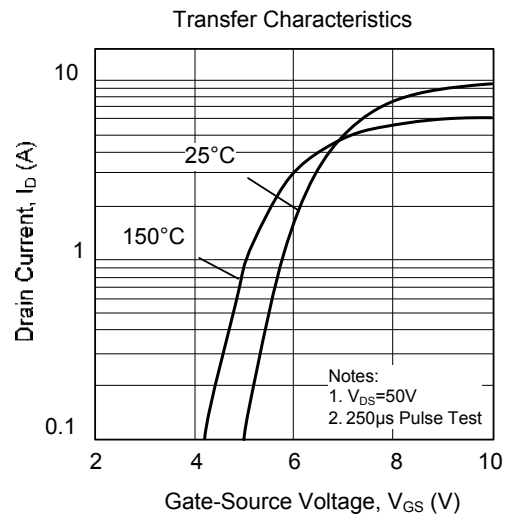
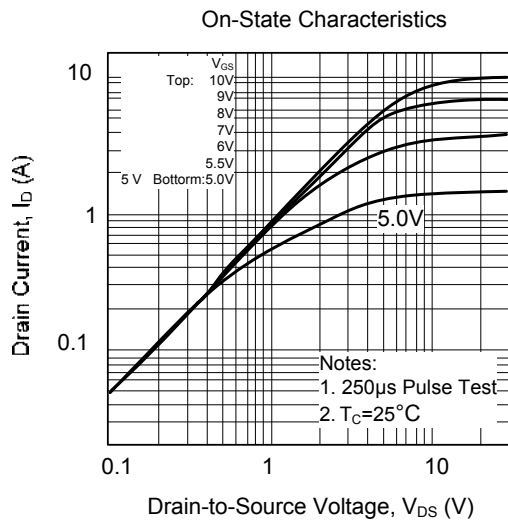
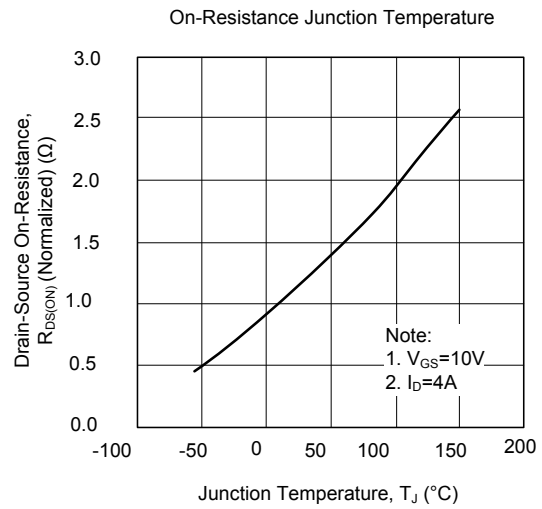
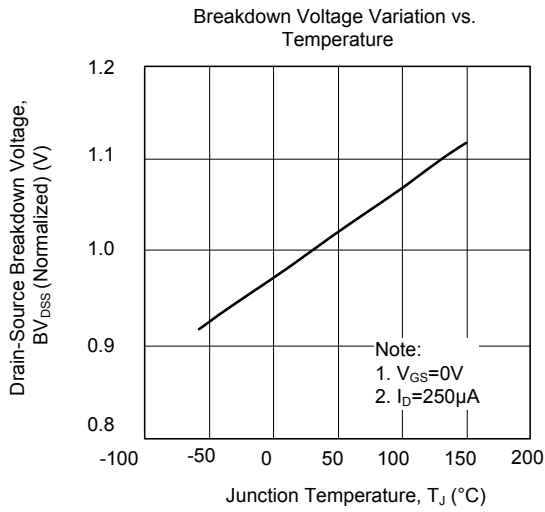

■ TYPICAL CHARACTERISTICS (Cont.)

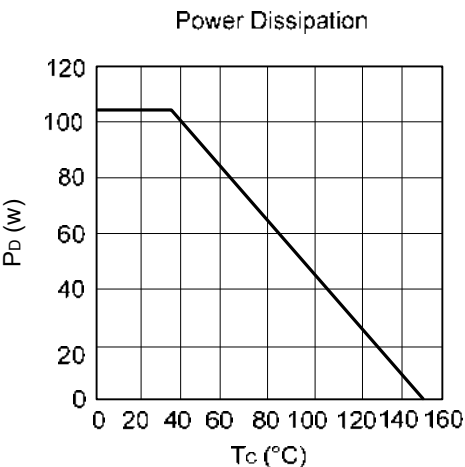
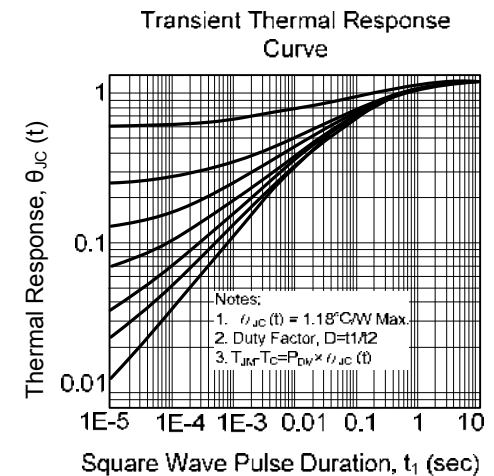
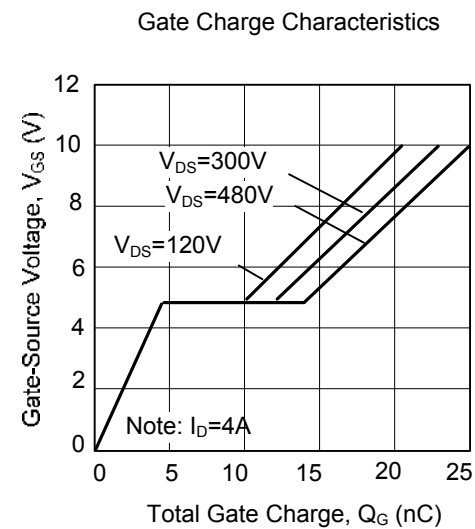
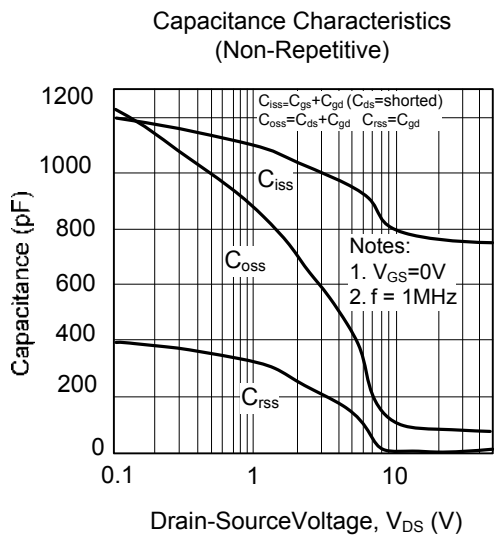
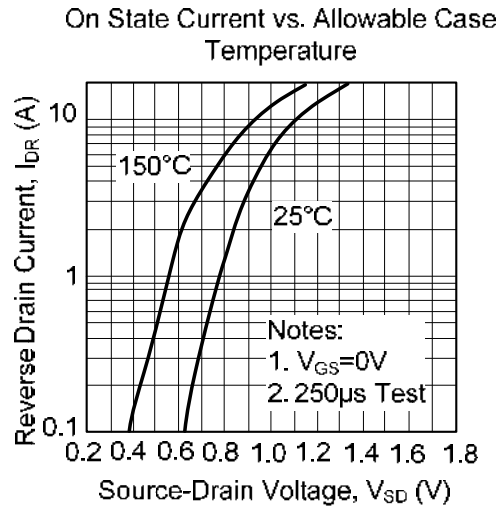
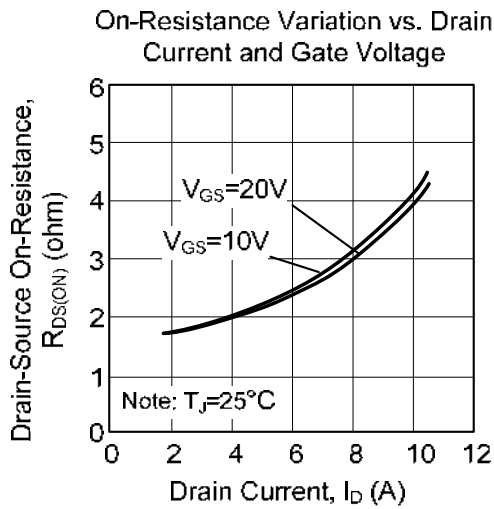

UTC assumes no responsibility for equipment failures that result from using products at values that exceed, even momentarily, rated values (such as maximum ratings, operating condition ranges, or other parameters) listed in products specifications of any and all UTC products described or contained herein. UTC products are not designed for use in life support appliances, devices or systems where malfunction of these products can be reasonably expected to result in personal injury. Reproduction in whole or in part is prohibited without the prior written consent of the copyright owner. UTC reserves the right to make changes to information published in this document, including without limitation specifications and product descriptions, at any time and without notice. This document supersedes and replaces all information supplied prior to the publication hereof.