

Product Specification

Customer :

Part NO. : MMB10016B-B10

Description : digital led display

Date : 2015-8-20

Micro Modern Electronic

Specification

型号 (TYPE NO.): MMB10016B-B10

1. 说明 (Description):

发光颜色 (Emitted Color): 红色, 共阳 RED, commom anode

外观颜色 (Lens Color): 黑、白两色

外形尺寸 (Max Size): 34.0*24.0*10.5mm

3. 绝对最大额定(Ta=25°C)Absolute Maximum Ratings:

功耗 Power Dissipation..... 70mW

脉冲顺向电流 Peak Forward Current..... 100mA

反向电压 Reverse Voltage..... 7V

工作温度 Operating Temperature..... -40°C ~+85°C

储存温度 Storage Temperature..... -40°C ~+85°C

储存湿度 Storage Humidity..... 45~85%

4. 光电特性(Ta=25°C)Electrical-Optical Characteristics:

参数 (Parameter)	测试条件 (Test CONDITING)	单位 (Symbol)	Min	Type	Max	单位 (Unit)
发光强度 Luminous Intensity	I _F =20mA	IV	-	100	-	mcd
直流正向电压 DC Forward Voltage	I _F =20mA	V _F	1.7	2.0	2.4	V
直流反向电流 DC Reverse Current	V _R = 5V	I _R	-	-	20	uA
波长 Wavelength Characteristic	I _F =20mA	λ _p	-	625	-	nm
建议使用顺向电流 Suggestion Forward Current	-	IF(Sug)	5	10	20	mA
抗静电能力 (人体模式) Electrostatic Discharge Threshold(HBM)	ESD	-		-	2000	V

Note: Soldering Bath: not more than 5 seconds at 260°C。 The bottom ends of plastic

Reflector should be at least 2mm above the solder surface。

Soldering Iron: not more than 3 seconds at 300°C under 30W。

第 2 页 共 5 页

Micro Modern Electronic

5.结构尺寸 (Mechanical Outline) :

(未注尺寸公差 Unspecified Tolerances is: X±0.3mm)

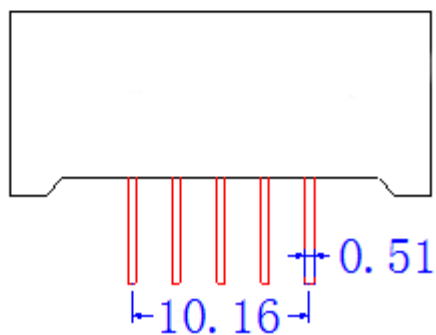
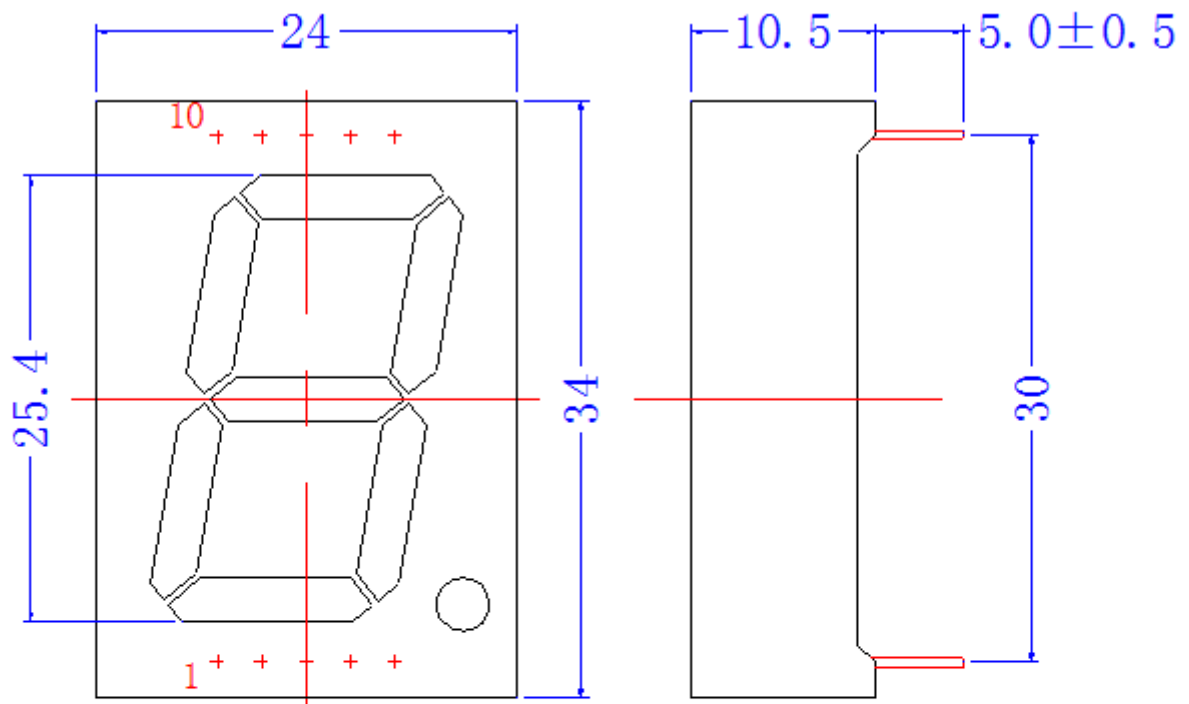

6. 电路图 (Circuit Diagram) :

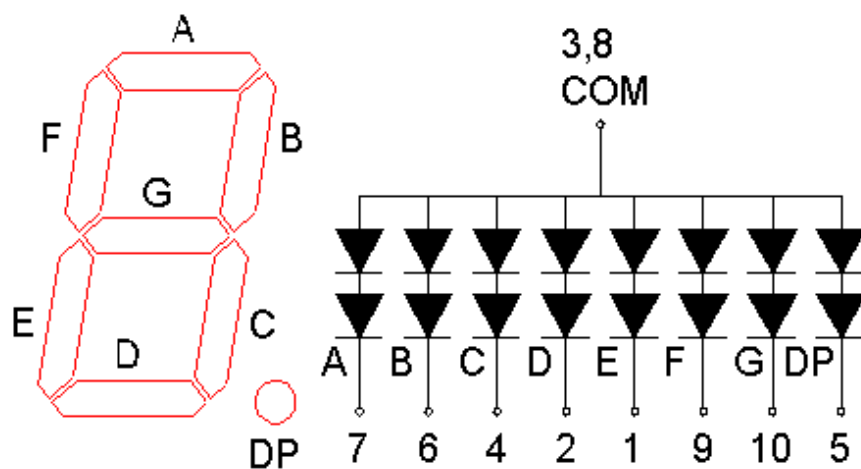

Micro Modern Electronic

8. 保存和焊接条件 (Storage & Soldering condition) :

- **Store with care. Storing the units in bad condition will cause the reflector sheet and decrease its adhesive power. Storage the products under the condition :temperature (25°C ± 10°C) and humidity 65%CRH±20%CRH (65°C CRH±20% CRH) our recommendation.**
 - 注意保存，保存条件不好时，会降低膜片与反射壳（导光板）的粘附力。推荐保存条件为：温度 25°C±10°C 湿度 65%CRH±20%CRH
- **The Soldering Temperature is 260±5°C and Soldering Time should be less than 3 sec, and soldering iron power should be less than 30W.**
 - 焊接温度 260°C±5°C，焊接时间小于 3 秒，烙铁功率小于 30W。
- **The soldering point should be farther than 1.6mm from body.**
 - 焊接点应离产品实体大于 1.6mm。

外观判定条件(Surface check condition)

1. 外观目测条件：40W 日光灯作光源与产品相距约 1 米（环境亮度）200 Lux）检测者与产品视距为 25-30cm。

Visual check condition: Use a 40W lamp as light (Ambient luminance about 200Lux), the distance between lamp and product about one meter, between checker and product about 25-30cm for check.

标准:

1. 黑/白点大小为 $0 \leq \phi \leq 0.20\text{mm}$ ，允许有 3 个，且不在同一字划。黑/白点大小 $\phi > 0.15\text{mm}$ ，不可接受。

Standard:

the size of black dot and white dot is $0 \leq \phi \leq 0.20\text{mm}$, and the quantity of the dot for three are accepted, and those distance must be not in same segment. the size of black dot and white dot is $\phi > 0.20\text{mm}$, that is not accepted.

2. 划伤 $\phi \leq 0.1\text{mm}$ ，长度 $< 1\text{mm}$ ，最多允许 1 条；机壳表面刮花，膜纸花，当产品不反光，且发光效果不见该缺陷时，则可接受。

Below the condition are accepted:

The scar is $\phi \leq 0.1\text{mm}$ and the length less than 1mm, the quantity of this scar for one is accepted.

Surface scar, if that cannot found when the product was luminous so that is accepted.

Micro Modern Electronic

2. 尺寸检测条件：依据图纸，使用计量卡尺，注意检测人为误差。

Size check condition: Use the measure ruler based on the product drawing for check, and need note that the tolerance make by operator.

3. 电性能检测条件：依据图纸，工艺，在额定工作电压或恒定的电流下，执行《FQC 成品检验标准》功能的相关内容。

Electrical check condition: use the rated voltage or constant current for the product based on the product drawing and IE document and performance the 《FQC 成品检验标准》 for check.

判定类别 Standard	判定范围 ITEM	MAJOR	MINOR
成品检验判定标准 Final product check standard	外观检验 Surface check condition	1.膜纸：不齐、贴歪 $\geq 0.50\text{mm}$ 。 Membrane: not uniform or deflective that must be less than 0.50mm. 2.引脚氧化或掉铜皮、或不按要求上锡披峰。 The pins are oxygenation or lose copper or cannot meet the SPEC of soldering reliability. 3.条形歪斜、松脱、脚短/长、膜纸变形、翘起。 Bar deflective, loss, pins short or longer, membrane distortion, tilt. 4.产品弯曲、变形、划伤、毛刺。 Product inflect, scar, burr.	1.膜纸不齐导致露出或超宽 0.50mm 内进 0.50mm 以下，0.50mm 以上；脏、皱等。 Make for bare or exceed width between 0.50mm and 0.50mm caused by membrane were not uniform; dirty, ruck etc. 2.产品反面非有效发光区域有手印、水渍印。 Has the fingerprint or watermark on the background of the product there are not the area of luminous.
	尺寸检验 Size check condition	1.长、宽、厚等重要尺寸超差 $\geq 0.25\text{mm}$ ，其它尺寸超差在 0.25mm 以上。 The tolerance of Length, width and thick must $\geq 0.25\text{mm}$ and other tolerance more than 0.25mm. 2.膜纸过大在 0.5mm 以上。 Membrane over than 0.50mm	1.虚边、毛刺等引起的尺寸超差在 0.25mm 以下,0.1mm 以上。 The size tolerance of product that caused by burr edge shall between 0.1-0.25mm. 2.小于严重缺陷的尺寸超差。 Less than the important tolerance .
	功能发光效果检查 Functional check condition	1.发光颜色不符合图纸要求。 The color of luminous is differenced for the SPEC. 2.闪亮、颜色/色差、暗光、暗带与样板相差较大。 Flash, color, dark light that more difference than the golden sample. 3.膜纸漏光直径 ≥ 0.25 。 For the membrane the diameter of light Leakage ≥ 0.25 .	1.轻微色差、暗光、暗带、暗斑。 Minor of the chromatism, dark light, dark spot. 2.两端部发光不均匀。 The luminescence is asymmetry at the two ends.