



PB-03F Specification

Version V1.0.0

Copyright©2021

Content

1. Product Overview.....	4
1.1. Characteristic.....	5
2. Main parameters.....	5
2.1. Static electricity requirements.....	6
2.2. Electrical characteristics.....	6
2.3. BLE RF performance.....	6
2.4. Power consumption.....	7
3. Appearance dimensions.....	8
4. Pin definition.....	9
5. Schematic.....	11
6. Antenna parameters.....	12
6.1. Test conditions for the antenna.....	12
6.2. Antenna S parameter.....	13
6.3. Antenna Gain and Efficiency.....	13
6.4. Antenna field type diagram.....	14
7. Design guidance.....	15
7.1. Module application circuit.....	15
7.2. Antenna layout requirements.....	16
7.3. Power supply.....	16
7.4. GPIO.....	18
8. Flow welding curve diagram.....	19
9. Product related models.....	20
10. Product packaging information.....	21
11. Contact us.....	21
Disclaimer and copyright notice.....	22
Notice.....	22

1. Product Overview

PB-03F is a BLE module developed by Shenzhen Ai-Thinker Technology Co.,Ltd.The core processor chip PHY6252(SSOP24)of this module is a BLE SoC with high integration and low power consumption,which is specially designed for various applications such as IoT,mobile devices,wearable electronic devices and smart homes.

PHY6252(SSOP24)chip has industry-leading low power consumption performance and RF performance,it supports BLE 5.2.The chip built in 64 KB SRAM,256KB flash,96 KB ROM,256bit efuse.The chip supports a variety of low-power working states and can meet the power consumption requirements of various application scenarios.RF output power can be adjusted to achieve the best balance among communication distance,communication rate and power consumption.

PB-03F module provide rich peripheral interfaces,including UART,PWM,ADC,I2C,SPI,PDM,DMA and up to 19 IOs.

PB-03F module has many unique hardware security mechanisms.Hardware encryption accelerator supports AES algorithm.

PB-03F module supports BLE with low power consumption:BLE 5.2 and BLE mesh.Bluetooth rate support:125Kbps,500Kbps,1Mbps,2Mbps.Support broadcast expansion,multi-broadcast,channel selection.

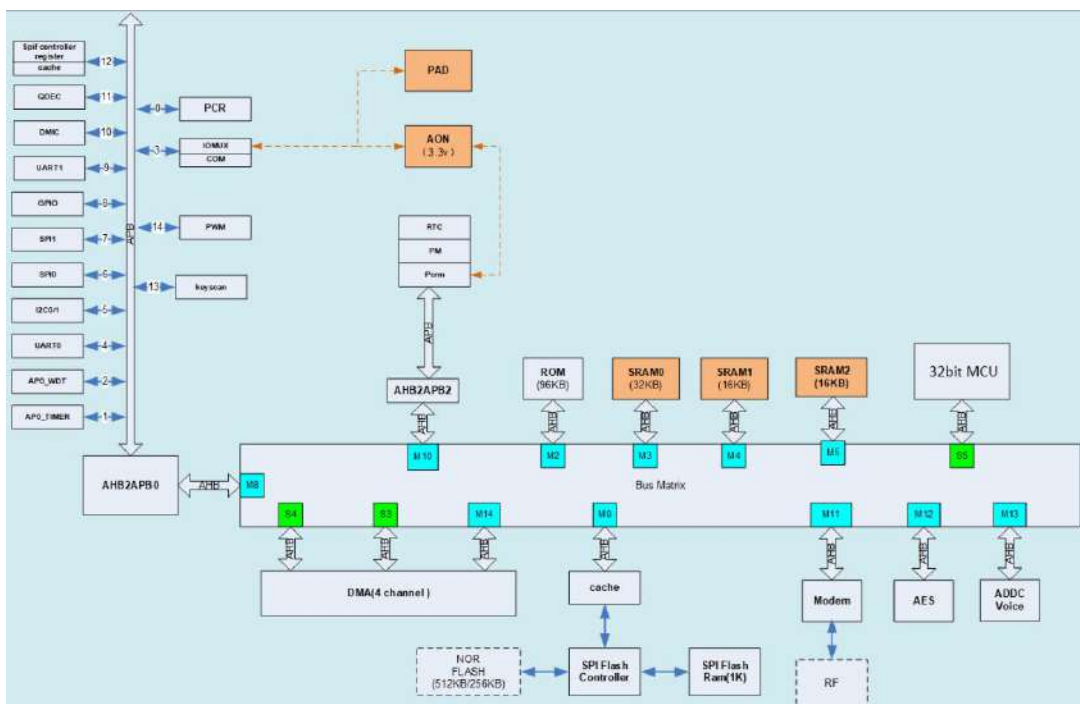

Figure 1 Main chip architecture diagram

1.1. Characteristic

- Support BLE5.2,rate support:125Kbps,500Kbps,1Mbps,2Mbps
- Own 64 KB SRAM, 256KB flash,96 KB ROM, 256bit efuse
- Support UART/GPIO/ADC/PWM/I2C/SPI/PDM/DMA interface
- Adopt SMD-22 package
- Support multiple sleep modes,deep sleep current is less than 1uA
- Support for serial local upgrade and remote Firmware upgrade(FOTA)
- Universal AT instructions can be used easy and quickly
- Support for secondary development,with an integrated Windows development environment

2. Main parameters

Table 1 Description of the main parameters

Model	PB-03F
Package	SMD-22
Size	24.0*16.0*3.1(±0.2)mm
Antenna	On-board antenna
Frequency	2400~2483.5MHz
Operating temperature	-40°C~85°C
Storage temperature	-40°C~125°C,<90%RH
Power supply	Voltage 2.7V~3.6V,Current>200mA
Interface	UART/GPIO/ADC/PWM/I2C/I2S/SPI/PDM/DMA
IO	19
UART rate	Default 115200 bps
Bluetooth	BLE 5.2
Security	AES-128
SPI Flash	256KB

2.1. Static electricity requirements

PB-03F is an electrostatic sensitive device, and special precautions must be taken when handling it.



Figure 2 ESD anti-static diagram

2.2. Electrical characteristics

Table 2 Electrical characteristics table

Parameters		Conditions	Min.	Typical value	Max.	Unit
Power supply voltage		VDD	2.7	3.3	3.6	V
I/O	V_{IL}/V_{IH}	-	-0.3/0.75V DD	-	0.25VDD/VDD +0.3	V
	V_{OL}/V_{OH}	-	N/0.8VIO	-	0.1VIO/N	V
	I_{MAX}	-	-	-	12	mA

2.3. BLE RF performance

Table 3 BLE RF performance table

Description	Typical values			Unit
Operating frequency	2400-2483.5			MHz
Output power				
Mode	Min.	typical value	Max.	Unit
BLE 2Mbps	-20	8	10	dBm
BLE 1Mbps	-20	8	10	dBm
BLE 500Kbps	-20	8	10	dBm
BLE 125kbps	-20	8	10	dBm
Receiving sensitivity				
Mode	Min.	typical value	Max.	Unit

BLE 2Mbps	-	-93	-	dBm
BLE 1Mbps	-	-96	-	dBm
BLE 500Kbps	-	-97	-	dBm
BLE 125Kbps	-	-102	-	dBm

2.4. Power consumption

The following power consumption data are based on a 3.3V power supply, ambient temperature of 25°C and measured using an internal regulator.

- All measurements were completed without the SAW filter at the antenna interface.
- All emission data were measured based on the TX_Burst_Test&RX_Burst_Test mode

Table 4 Power consumption table

Mode	Min.	Average value	Max.	Unit
TX_Burst_Test Power output 8dBm	-	11.5	-	mA
TX_Burst_Test Power output 5dBm	-	9	-	mA
TX_Burst_Test Power output 0dBm	-	8	-	mA
RX_Burst_Test	-	9.4	-	mA
Deep Sleep(With broadcast,1 second interval)	-	50.58	-	uA
Deep Sleep(With broadcast,2 seconds interval)	-	28.25	-	uA
Deep Sleep(Without broadcast)	-	7.2	-	uA
Power Off	-	0.57	-	uA

3. Appearance dimensions

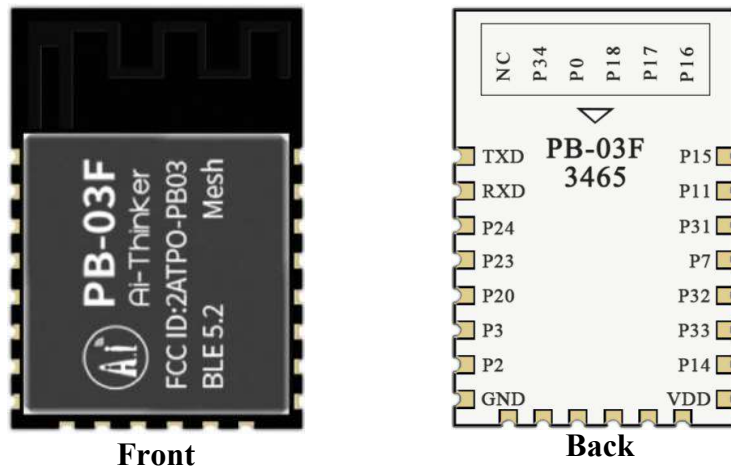

Figure 3 Appearance diagram pictures is for reference only,subject to physical objects)

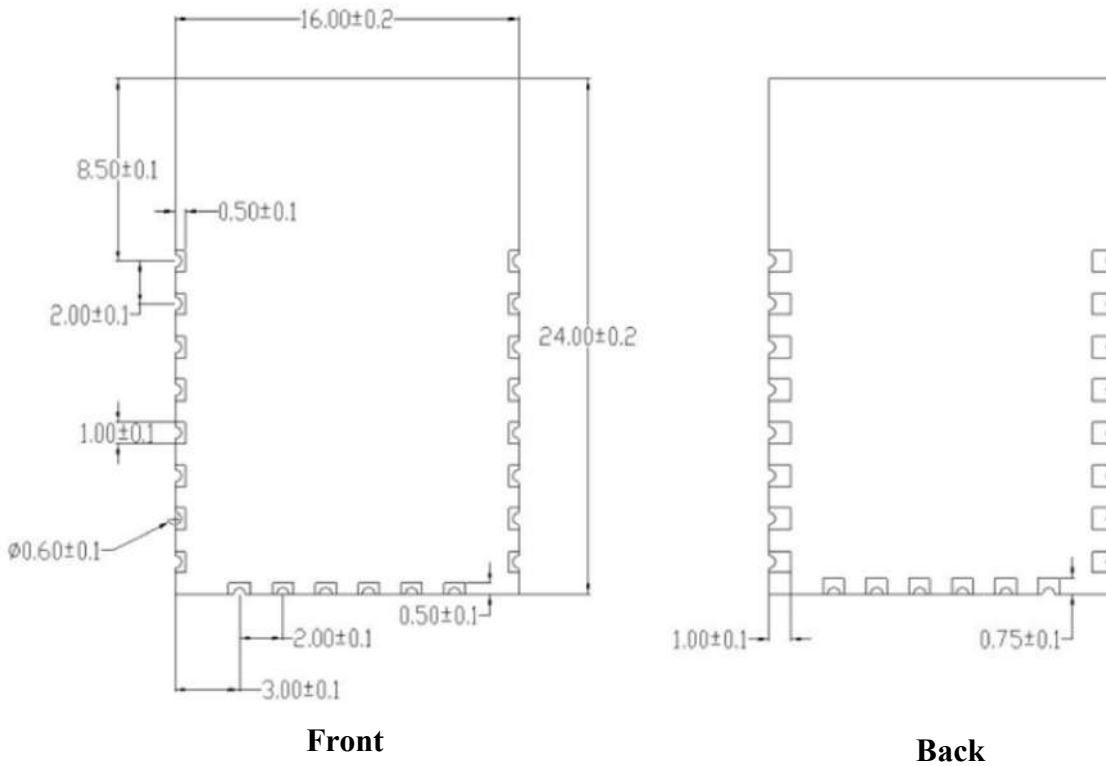

Figure 4 Module size diagram

4. Pin definition

PB-03F has a total of 22 interfaces. As shown in below pin diagram, the pin function definition table is the interface definition.

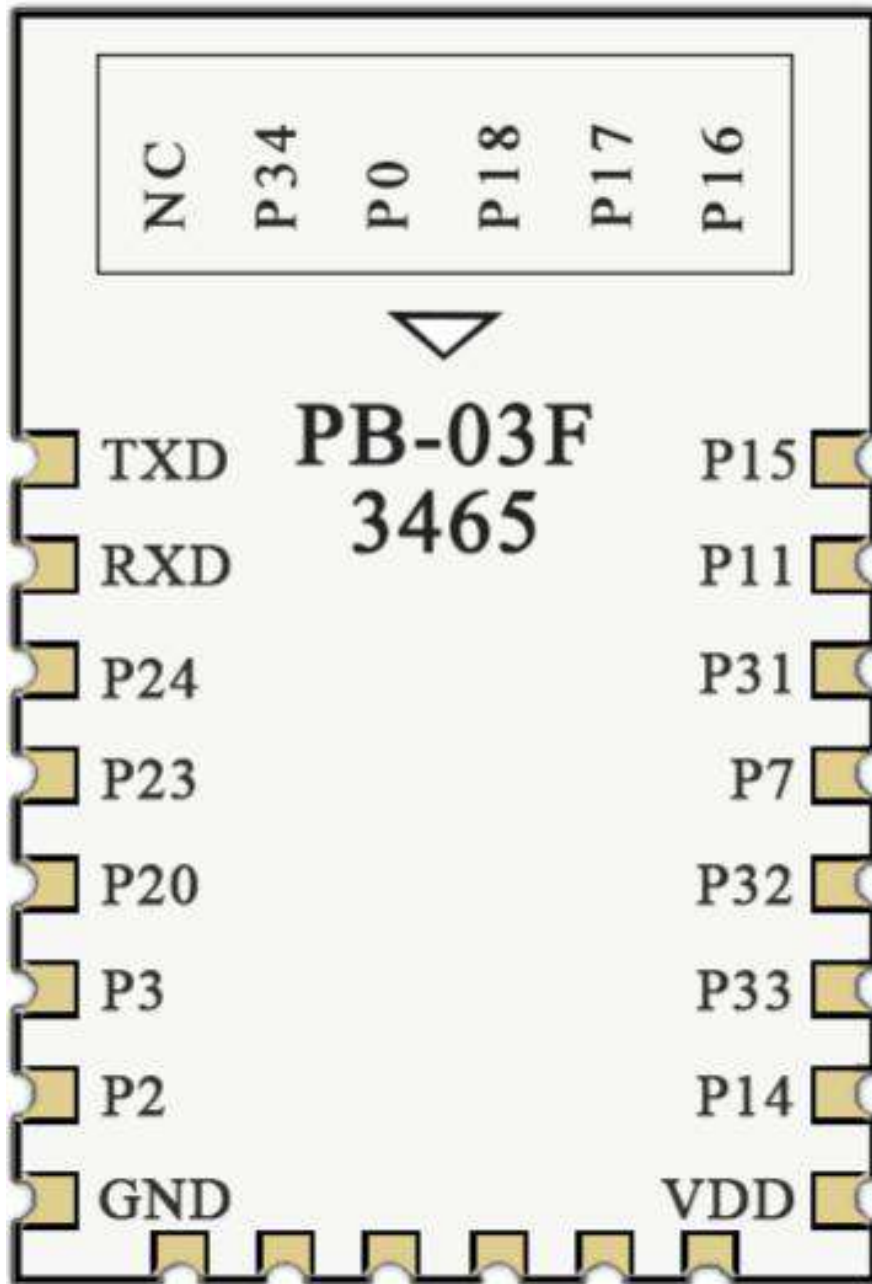

Figure 5 Schematic diagram of module pins(back view)

Table 6 Pin function definition table

No.	Name	Function
1	P15	GPIO15/ADC input 4/micbias output
2	P11	GPIO11/ADC input 0
3	P31	GPIO31
4	P7	GPIO7
5	P32	GPIO32
6	P33	GPIO33
7	P14	GPIO14/ADC input 3
8	VDD	Power input
9	P16	GPIO16/32.768KHz crystal input
10	P17	GPIO17/32.768KHz crystal output
11	P18	GPIO18/ADC input 7/PGA negative input
12	P0	GPIO0
13	P34	GPIO34
14	NC	Empty
15	GND	Ground(Power negative electrode)
16	P2	GPIO2/SWD debug data inout
17	P3	GPIO3/SWD debug clock
18	P20	GPIO20/ADC input 9/PGA positive input
19	P23	GPIO23/ADC input 1/micbias reference
20	P24	GPIO24/ADC input 2
21	P10	RXD/GPIO10
22	P9	TXD/GPIO9

5. Schematic

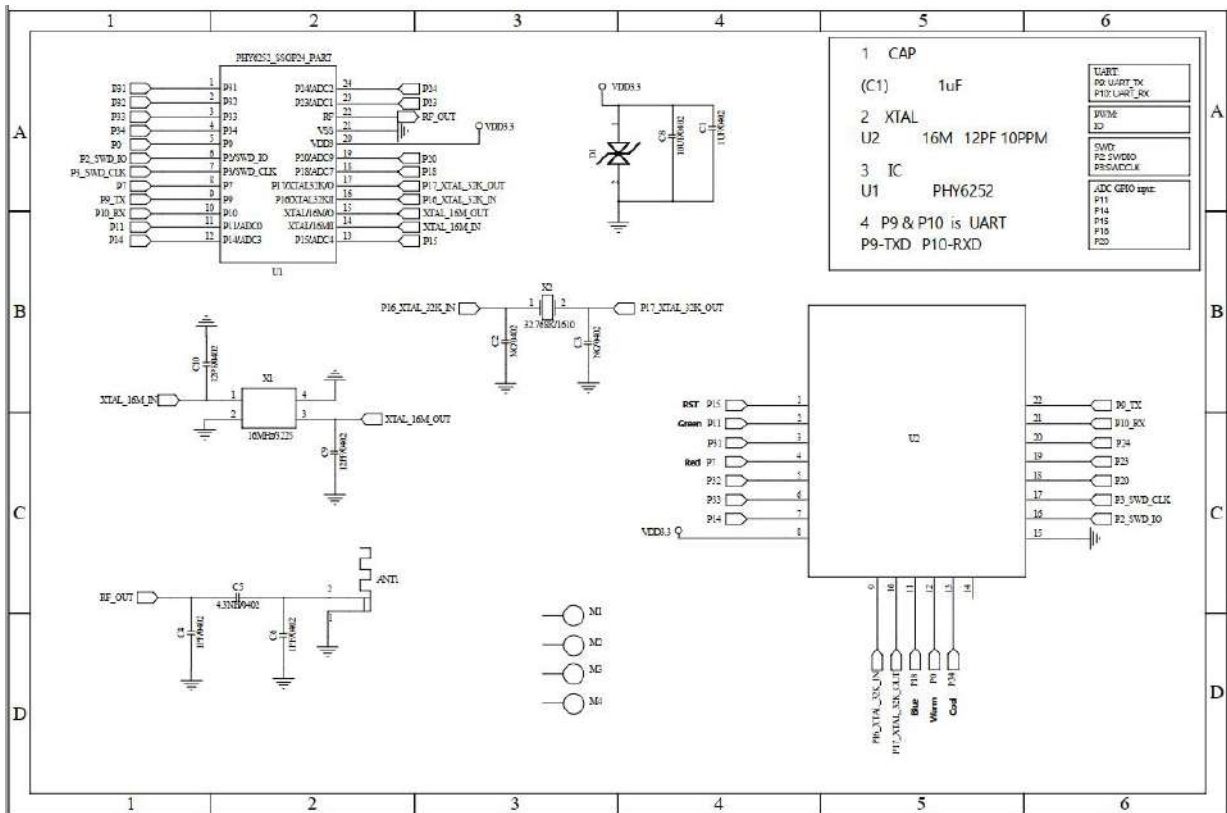

Figure 6 Module schematic

6. Antenna parameters

6.1. Test conditions for the antenna



Figure 7 Antenna test conditions

6.2. Antenna S parameter

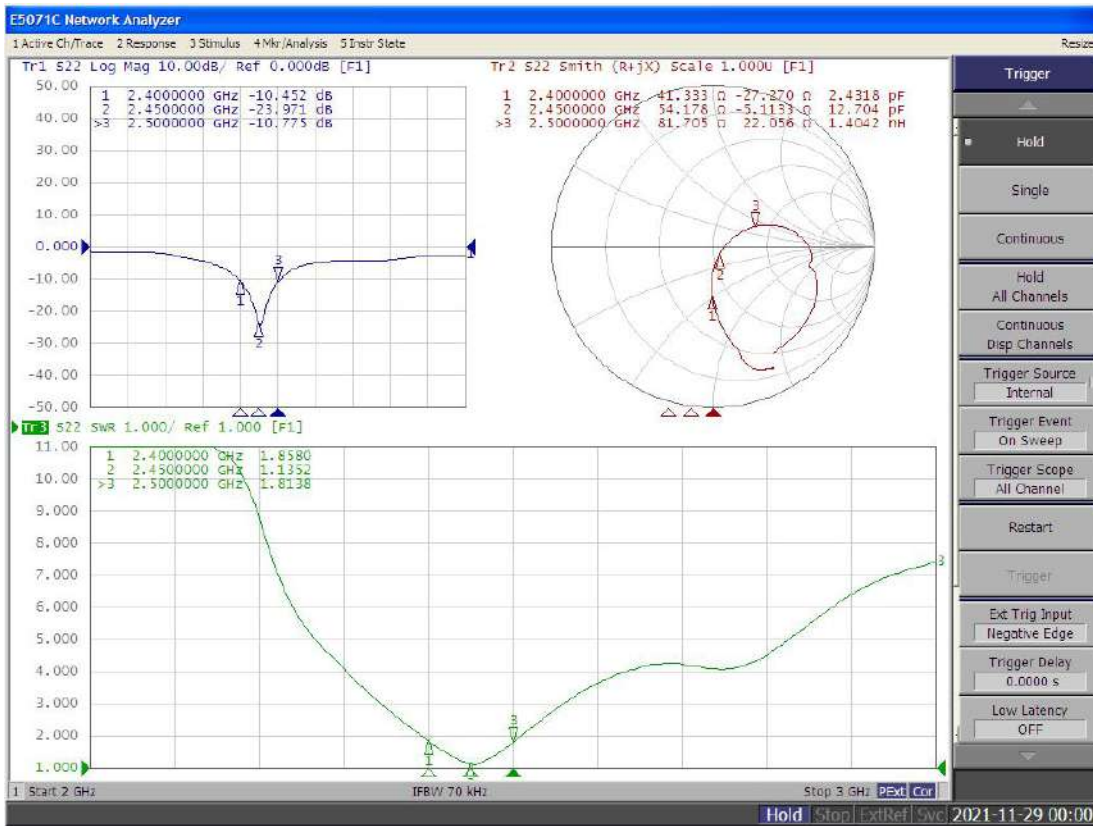

Figure 8 Antenna S parameters

6.3. Antenna Gain and Efficiency

Table 7 Antenna Gain and efficiency

Frequency ID	1	2	3	4	5	6	7	8	9	10	11
Frequency(MHz)	2400.0	2410.0	2420.0	2430.0	2440.0	2450.0	2460.0	2470.0	2480.0	2490.0	2500.0
Gain(dBi)	1.99	1.84	2.15	1.68	1.70	1.52	1.38	1.45	1.78	1.47	1.62
Efficiency(%)	77.76	76.14	81.08	73.60	74.80	71.89	68.92	69.55	72.83	66.53	69.30

6.4. Antenna field type diagram

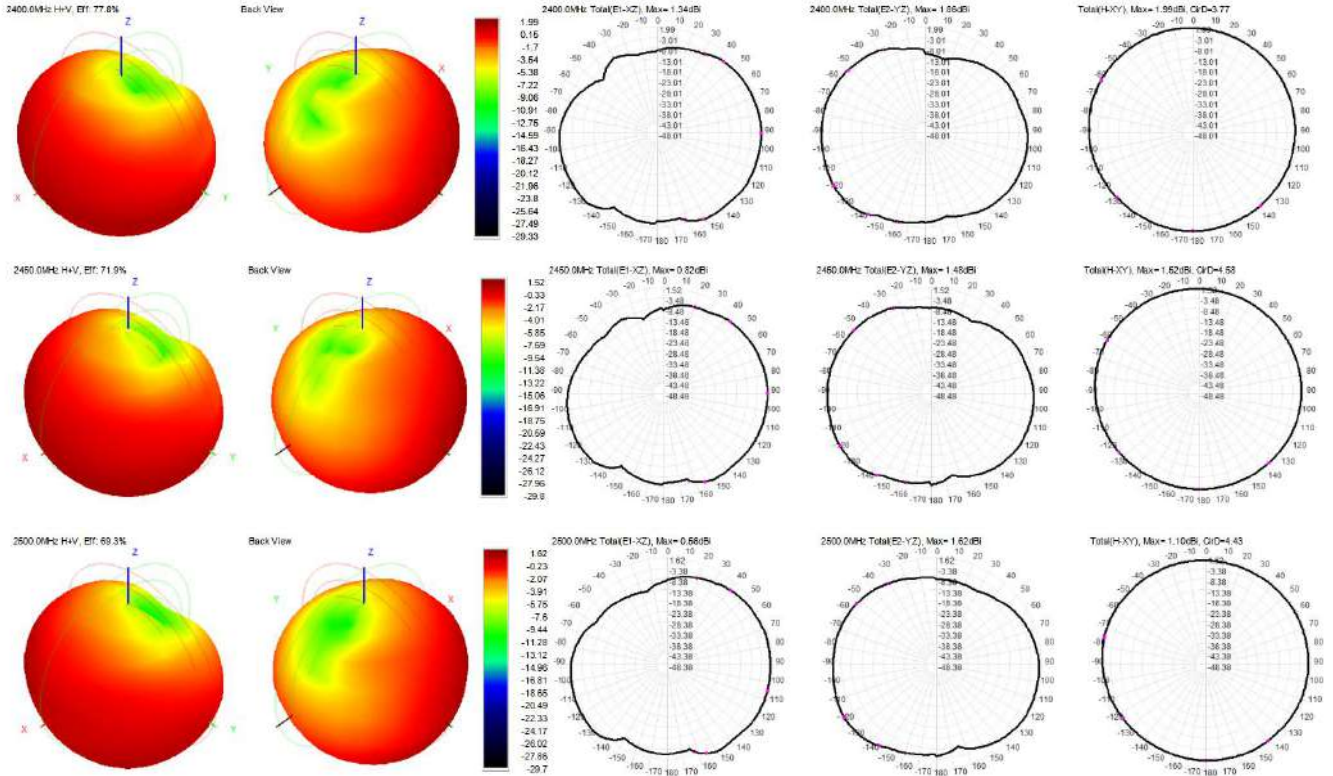

Figure 9 Antenna field type diagram

7. Design guidance

7.1. Module application circuit

($\geq 200\text{mA}$, suggest use DC-DC or LDO independent power supply)

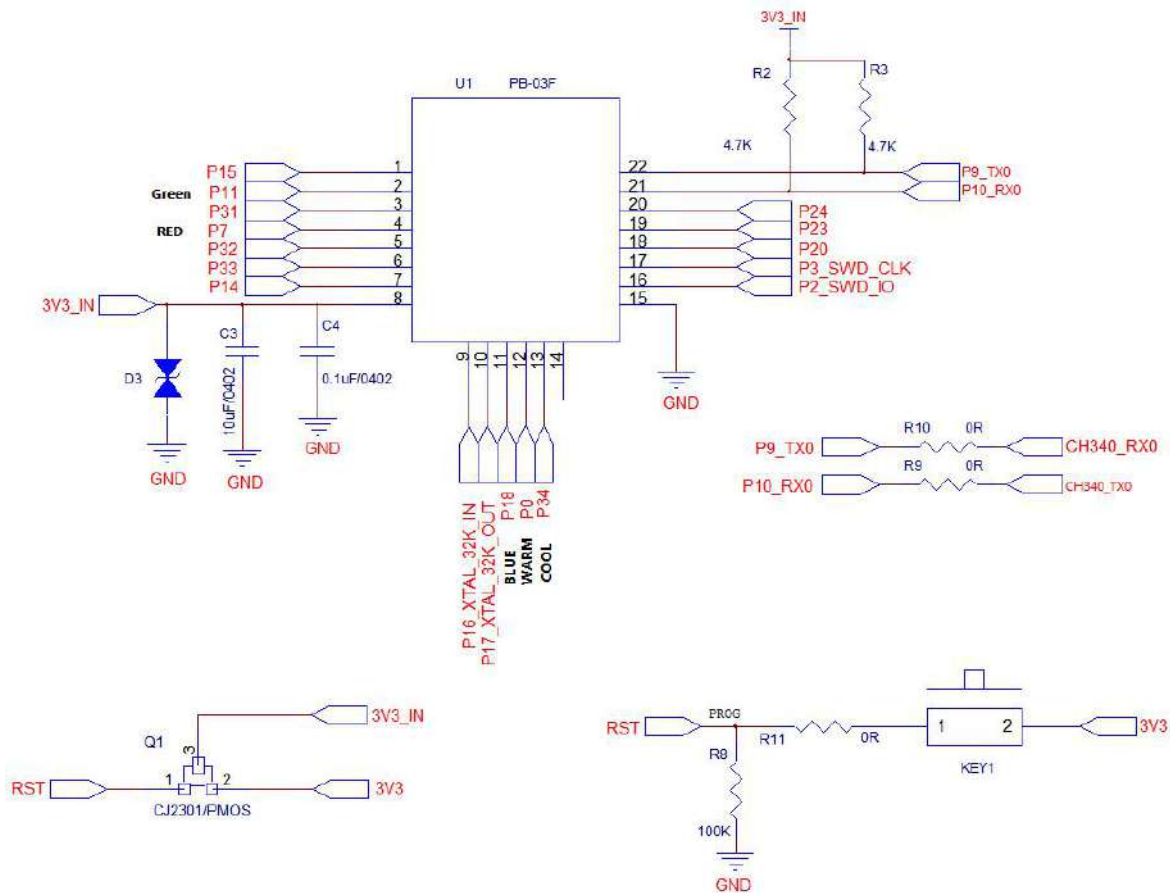

Figure 10 Application circuit diagram

Note:

- Because the PB-03M does not have the reset pin, we can achieve the reduction by power off, we can restore the module with a PMOS to achieve the reduction of power off.
- TX&RX serial port line, 2 resistors are reserved, in series in the line. The 3.3V voltage used to prevent the serial port affects the reset of the module.

7.2. Antenna layout requirements

- The installation position on the motherboard suggests the following 2 ways:

Scheme 1: Put the module on the edge of the motherboard, and the antenna area out of the motherboard edge

Scheme 2: Put the module on the edge of the motherboard, and empty an area along the antenna position.

- To meet the performance of the on-board antenna, metal parts are not placed around the antenna, away from the high-frequency device

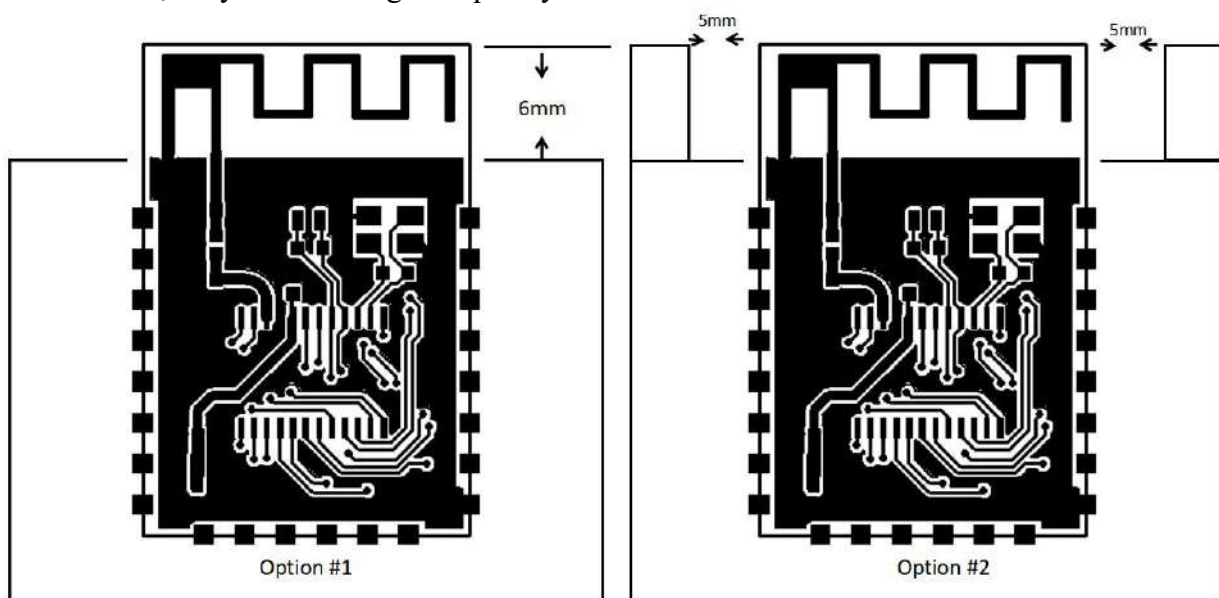

Figure 11 Schematic diagram of the antenna layout

7.3. Power supply

- Recommended 3.3V voltage, peak current over 200mA.
- Power supply is recommend to use LDO; If the DC-DC is used, the ripple is recommended to be controlled within 30mV
- The DC-DC power supply circuit proposes to reserve the dynamic response capacitance to optimize the output ripple with large load changes.
- 3.3V power interface it is recommended to add ESD devices.

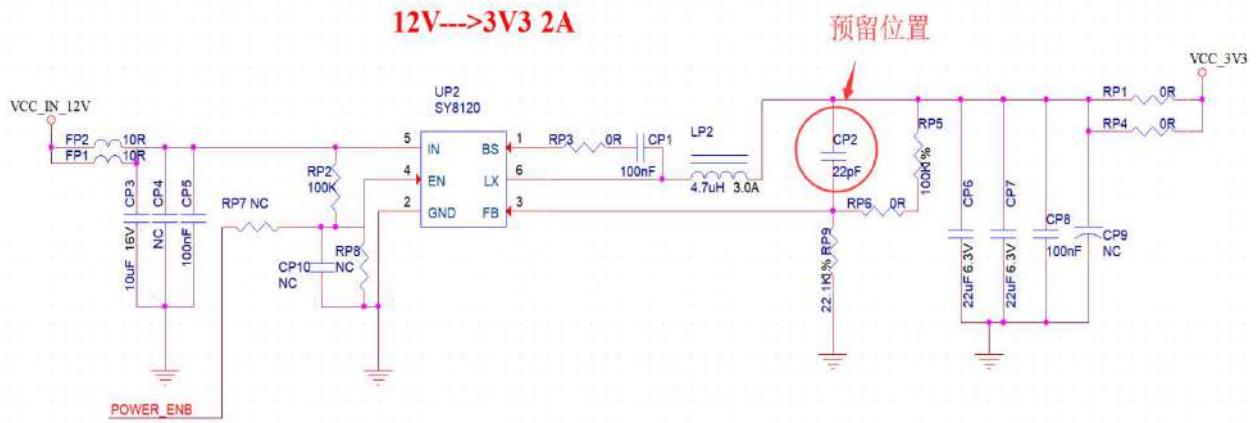

Figure 12 The DC-DC C antihypertensive circuit diagram

7.4. GPIO

- Some IO ports are lead outside the module,if using,a proposed resistance of 10-100 ohms on the IO port.This suppresses the overshoot and enables smoother levels on both sides,helping for both EMI and ESD.
- The up and down of the special IO port should refer to the use instructions of the specification,which will affect the start-up configuration of the module.
- The IO port of the module is 3.3V,if the main control does not match the IO port level of the module,the level conversion circuit should be increased.
- If the IO port is directly connected to the peripheral interface,or terminals such as pin header,it is recommended to reserve ESD devices at the IO port line near the terminal.

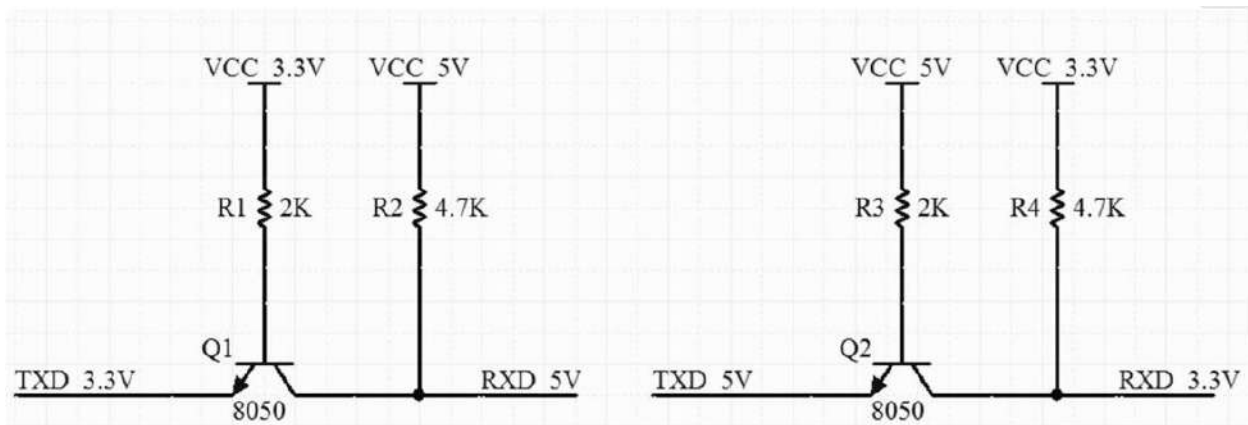

Figure 13 Level convert circuit

8. Flow welding curve diagram

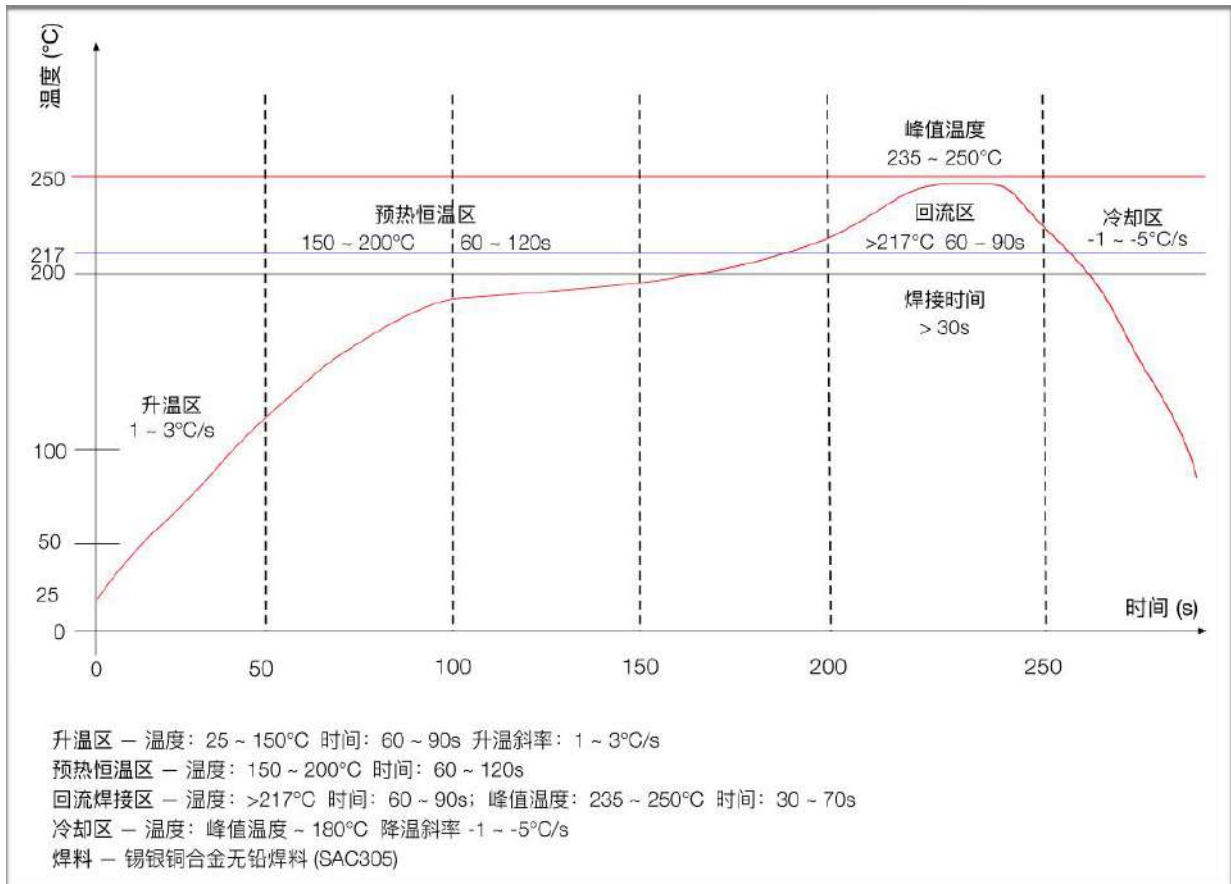

Figure 14 Flow welding diagram

9. Product related models

Table 8 Product related model list

Model	Power Supply	Package	Size	Antenna
PB-03F	2.7V~3.6V, I>200mA	SMD-22	24.0*16.0*3.1(± 0.2)mm	On-board PCB
PB-03M	2.7V~3.6V, I>200mA	DIP-18 Gold finger plugin	18.0*18.0*2.8(± 0.2)mm	On-board PCB
PB-03	2.7V~3.6V, I>200mA	SMD-61	16.6*13.2*2.8(± 0.2)mm	On-board PCB
NodeMCU- PB-03F-Kit	5V, I>200mA	DIP-30	49.3*25.4*12.9(±0.2)mm	On-board PCB
NodeMCU- PB-03M-Kit	5V, I>200mA	DIP-20	32.8*28.6*18.3(±0.2)mm	On-board PCB
NodeMCU- PB-03-Kit	5V, I>200mA	DIP-30	49.3*25.4*12.9(±0.2)mm	On-board PCB
Product related information: https://docs.ai-thinker.com				

10. Product packaging information

PB-03F module was packaged in a tape,800pcs/reel.As shown in the below image:



Figure 15 Package and packing diagram

11.Contact us

[Ai-Thinker official website](#)

[Office forum](#)

[Develop DOCS](#)

[LinkedIn](#)

[Tmall shop](#)

[Taobao shop](#)

[Alibaba shop](#)

[Technic support email: support@aithinker.com](mailto:support@aithinker.com)

[Domestic business cooperation: sales@aithinker.com](mailto:sales@aithinker.com)

[Overseas business cooperation: overseas@aithinker.com](mailto:overseas@aithinker.com)

Company Address: Room 403,408-410, Block C, Huafeng Smart Innovation Port, Gushu 2nd Road, Xixiang, Baoan District, Shenzhen.

Tel: +86-0755-29162996



Wechat mini program



Wechat official account

Disclaimer and copyright notice

The information in this article, including the URL address for reference, is subject to change without notice.

The document is provided "as is" without any guarantee responsibility, including any guarantee for merchantability, suitability for a specific purpose, or non-infringement, and any guarantee mentioned elsewhere in any proposal, specification or sample. This document does not bear any responsibility, including the responsibility for infringement of any patent rights arising from the use of the information in this document. This document does not grant any license for the use of intellectual property rights in estoppel or other ways, whether express or implied.

The test data obtained in the article are all obtained from Ai-Thinker's laboratory tests, and the actual results may vary slightly.

All brand names, trademarks and registered trademarks mentioned in this article are the property of their respective owners, and it is hereby declared.

The final interpretation right belongs to Shenzhen Ai-Thinker Technology Co., Ltd.

Notice

Due to product version upgrades or other reasons, the contents of this manual may be changed.

Shenzhen Ai-Thinker Technology Co., Ltd. reserves the right to modify the contents of this manual without any notice or prompt.

This manual is only used as a guide. Shenzhen Ai-Thinker Technology Co., Ltd. makes every effort to provide accurate information in this manual. However, Shenzhen Ai-Thinker Technology Co., Ltd. does not guarantee that the contents of the manual are completely free of errors. All statements and information in this manual And the suggestion does not constitute any express or implied guarantee.