



Shenzhen Hi-Link Electronic Co., Ltd

5W DC/DC power module 24V series
HLK-5D2405/ HLK-5D2412/ HLK-5D2415/ HLK-5D2424



Contents

1. DC/DC power module	1
2. Product model.....	1
3. Product features.....	1
4. Environmental conditions.....	2
5. Electrical characteristics.....	2
5.1. Input Features.....	2
5.2. Output characteristics (5V/1000mA).....	3
5.3. Output characteristics (12V/420mA).....	4
5.4. Output characteristics (15V/330mA).....	5
5.5. Output characteristics (24V/210mA).....	6
6. Derating curve.....	6
7. Typical applied circuit.....	7
7.1 EMC Parameter recommendation.....	8
7.2 Output filtering.....	8
8. Test application.....	9
8.1. DC/DC Test circuit.....	9
8.2. Ripple and noise test.....	9
9. Marking, packaging, transportation, storage.....	10
9.1. Marking.....	10
9.1.1. Product mark.....	10
9.1.2. Packaging mark.....	10
9.2. Packaging.....	10
9.3. Transportation.....	10
9.4. Storage.....	10
10. Dimension and weight.....	11

1. DC/DC Power Module

5W DC-DC series power module is a small size converter, 2:1 wide voltage input range, efficiency up to 84%, 1500VDC conventional isolation voltage, allowable operating temperature -40°C to +85°C, with output over-voltage, over-current, short circuit Protection functions, widely used in medical, industrial control, electric power, instrumentation, communications, railway and other fields.

2. Product model

Model	Shell size (mm)	Output power (W)	Output voltage (V)	Output current (mA)	Notes
HLK-5D2405	25.4*25.4*11	5	5	1000	
HLK-5D2412		5	12	420	
HLK-5D2415		5	15	330	
HLK-5D2424		5	24	210	

3. Product features

1. Ultra wide range input (2:1), output 5W
2. Conversion efficiency: 84% (Typ)
3. Isolation voltage: 1500Vdc
4. Ultra low standby power consumption: 0.3W (typical)
5. Ultra fast start: 100mS (typical)
6. Operating temperature range: -40 ° C ~ +85 ° C
7. Output protection: short circuit protection, over current protection, over voltage protection
8. Metal case, low output ripple
9. International standard pin, PCB board in-line installation
10. It is sealed with high quality environmental protection waterproof and thermal conductive glue, moisture proof and vibration proof, and meets the requirements of waterproof and dust proof IP65.
11. High reliability, long life design, long continuous working time

4. Environment conditions

Items	Technical parameters	Unit	Remarks
Working temperature	-40~+85	℃	
Storage temperature	-40~+80	℃	
Relative humidity	5~95	%	
Heat dissipation method	Natural cooling		
Atmospheric pressure	80~106	Kpa	
Vibration	Vibration coefficient 10~500Hz, 2G10min./1cycle, 60min.each along X,Y,Z axes		Meet secondary road transport requirements

5. Electrical characteristics

5.1. Input Features

Items	Working conditions	Unit	Remarks
Rated input voltage	24	Vdc	
Input voltage range	18-36	Vdc	
Max input current	≤0.7	A	
Reflected ripple current	---	mA	DC24V rated input voltage series
Impulse voltage	≤50	Vdc	
Starting voltage	9	Vdc	
Input under voltage protection	---	Vdc	
Start delay time	100	ms	Rated input voltage and constant resistance load
Input filter type			PI version
Hot plug			No-support
Remote end (Ctrl)*	Module open		--
	Module closed		--
	Input current when turned off	mA	-- -- --

Notes: Test at room temperature

5.2. Output characteristics (5V/1000mA)

Items	Technical parameters	Unit	Remarks
No-load rated output voltage	5V±2%	Vdc	
Short time maximum output current	≥1200	mA	
Rated output current	1000	mA	
Voltage regulation	±0.5	%	
Load Regulation	±1	%	
Conversion efficiency	Vin=24Vdc, Output full load 84	%	
Output ripple and noise (mVp-p)	≤100 Pure resistive load, 20MHz bandwidth, peak to peak value	mV	
Output voltage regulation	----	-	No adjustment
Output over-current protection	Output 110-200% of the maximum load	A	
Output short circuit protection	Direct short circuit during normal output, automatically resume normal operation after short circuit removal		Does not damage the whole machine
Output over-voltage protection	Output 110-160% of the maximum voltage	Vdc	
Insulation voltage	Input-output, test time 1 minute, leakage current less than 1mA/1500V	-	
Insulation resistance	Input-output, insulation voltage 500VDC/1000MΩ	MΩ	
Isolated capacitor	Input-output, 100KHz/0.1V 1000pF	-	

Notes:

- (1) For product model with output voltage ±5VDC or ±9VDC , the maximum output voltage accuracy is ±5% under 0% - 5% load condition
- (2) When tested according to the 0%-00% load working condition, the load adjustment rate is ±5%
- (3) 0%-5% load ripple & noise less than or equal to 5% Vo. Ripple and noise test method, Twisted pair test method, can add capacitive load at the output to reduce light load ripple.

5.3. Output characteristics (12V/420mA)

Items	Technical parameters	Unit	Remarks
No-load rated output voltage	12V±2%	Vdc	
Short time maximum output current	≥520	mA	
Rated output current	420	mA	
Voltage regulation	±0.5	%	
Load Regulation	±1	%	
Conversion efficiency	Vin=24Vdc, Output full load 84	%	
Output ripple and noise (mVp-p)	≤100 Pure resistive load, 20MHz bandwidth, peak to peak value	mV	
Output voltage regulation	----	-	No adjustment
Output over-current protection	Output 110-200% of the maximum load	A	
Output short circuit protection	Direct short circuit during normal output, automatically resume normal operation after short circuit removal		Does not damage the whole machine
Output over-voltage protection	Output 110-160% of the maximum voltage	Vdc	
Insulation voltage	Input-output, test time 1 minute, leakage current less than 1mA/1500V	-	
Insulation resistance	Input-output, insulation voltage 500VDC/1000MΩ	MΩ	
Isolated capacitor	Input-output, 100KHz/0.1V 1000pF	-	

Notes:

- (1) For product model with output voltage ±5VDC or ±9VDC , the maximum output voltage accuracy is ±5% under 0% - 5% load condition
- (2) When tested according to the 0%-00% load working condition, the load adjustment rate is ±5%
- (3) 0%-5% load ripple & noise less than or equal to 5% Vo. Ripple and noise test method, Twisted pair test method, can add capacitive load at the output to reduce light load ripple.

5.4. Output characteristics (15V/330mA)

Items	Technical parameters	Unit	Remarks
No-load rated output voltage	15V±2%	Vdc	
Short time maximum output current	≥430	mA	
Rated output current	330	mA	
Voltage regulation	±0.5	%	
Load Regulation	±1	%	
Conversion efficiency	Vin=24Vdc, Output full load 84	%	
Output ripple and noise (mVp-p)	≤100 Pure resistive load, 20MHz bandwidth, peak to peak value	mV	
Output voltage regulation	----	-	No adjustment
Output over-current protection	Output 110-200% of the maximum load	A	
Output short circuit protection	Direct short circuit during normal output, automatically resume normal operation after short circuit removal		Does not damage the whole machine
Output over-voltage protection	Output 110-160% of the maximum voltage	Vdc	
Insulation voltage	Input-output, test time 1 minute, leakage current less than 1mA/1500V	-	
Insulation resistance	Input-output, insulation voltage 500VDC/1000MΩ	MΩ	
Isolated capacitor	Input-output, 100KHz/0.1V 1000pF	-	

Notes:

- (1) For product model with output voltage ±5VDC or ±9VDC , the maximum output voltage accuracy is ±5% under 0% - 5% load condition
- (2) When tested according to the 0%-00% load working condition, the load adjustment rate is ±5%
- (3) 0%-5% load ripple & noise less than or equal to 5% Vo. Ripple and noise test method, Twisted pair test method, can add capacitive load at the output to reduce light load ripple.

5.5. Output characteristics (24V/210mA)

Items	Technical parameters	Unit	Remarks
No-load rated output voltage	24V±2%	Vdc	
Short time maximum output current	≥310	mA	
Rated output current	210	mA	
Voltage regulation	±0.5	%	
Load Regulation	±1	%	
Conversion efficiency	Vin=24Vdc, Output full load 84	%	
Output ripple and noise (mVp-p)	≤100 Pure resistive load, 20MHz bandwidth, peak to peak value	mV	
Output voltage regulation	----	-	No adjustment
Output over-current protection	Output 110-200% of the maximum load	A	
Output short circuit protection	Direct short circuit during normal output, automatically resume normal operation after short circuit removal		Does not damage the whole machine
Output over-voltage protection	Output 110-160% of the maximum voltage	Vdc	
Insulation voltage	Input-output, test time 1 minute, leakage current less than 1mA/1500V	-	
Insulation resistance	Input-output, insulation voltage 500VDC/1000MΩ	MΩ	
Isolated capacitor	Input-output, 100KHz/0.1V 1000pF	-	

Notes:

- (1) For product model with output voltage ±5VDC or ±9VDC , the maximum output voltage accuracy is ±5% under 0% - 5% load condition
- (2) When tested according to the 0%-00% load working condition, the load adjustment rate is ±5%
- (3) 0%-5% load ripple & noise less than or equal to 5% Vo. Ripple and noise test method, Twisted pair test method, can add capacitive load at the output to reduce light load ripple.

6. Derating curve

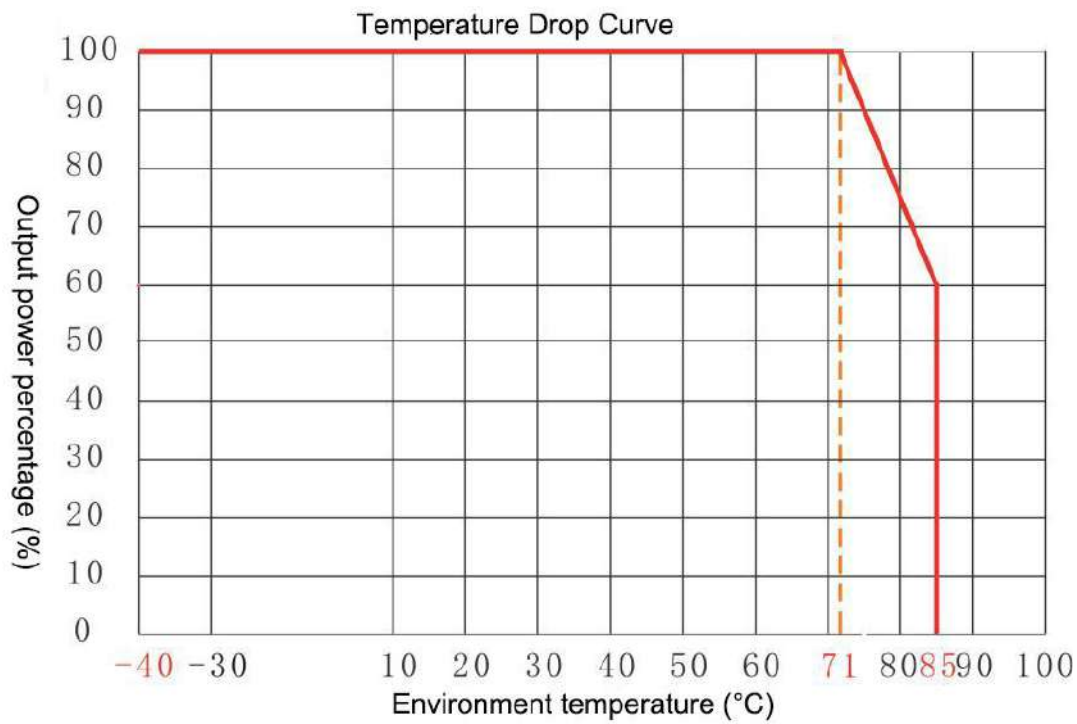

7. Typical applied circuit

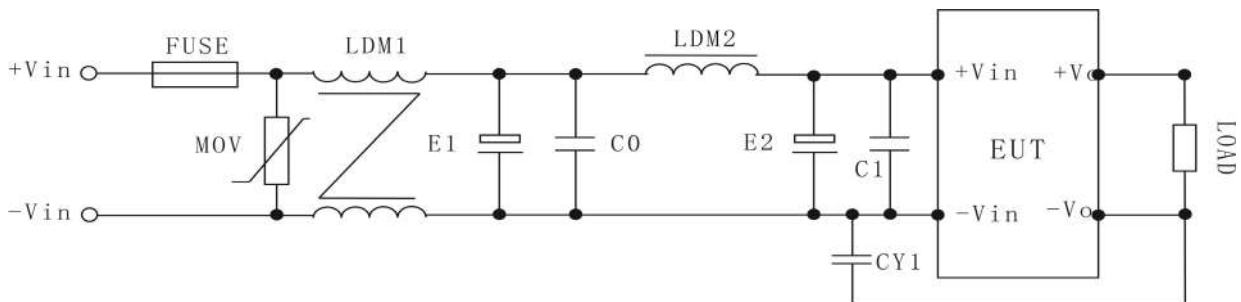

7.1 EMC Parameter recommendation

Component Tag / Recommended accessory	Function	Recommended value
FUSE	Protect the circuit from damage when the module is abnormal	Access the corresponding fuse according to customer needs
MOV1/Varistor	Protect the module from damage when accumulating surges	14D330K
LDM1/Common mode inductance	EMI filtering	Inductance: 10-30mH
C0, C1 Ceramic capacitors	Filter capacitor	1uF/50V
E1, E2 Electrolytic capacitor	Filter capacitor	100uF/50V
LDM2/ Differential mode inductance	EMI filtering	10-68uH

Remarks:

- * Fuses and varistors are basic parts of protection circuits (required).
- * If the certification is required, the safety capacitor and common mode inductance cannot be omitted.

7.2 Output filtering

Single output

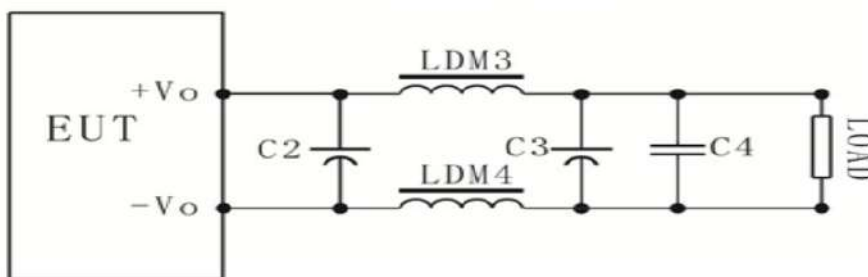

For usual requirements of ripple and noise, the peripheral recommendation is only C2;
For strict requirements of ripple and noise, the above circuit is recommended.

Notes:

- (1) C2, C3 use high frequency low resistance electrolytic capacitor, and the total capacity can not exceed the maximum capacitive load indicated in the manual, otherwise the module will not start normally.
- (2) When the capacitive load is used, the minimum load of 3% must be guaranteed, otherwise the module output will be abnormal.

Component Tag / Recommended accessory	Function	Recommended value
LDM3/ Common mode inductance	Adjust the output ripple voltage	Inductance: 0.47-4.7uH according to the debugging result
LDM4/ Common mode inductance	Adjust the output ripple voltage	Inductance: 0.47-4.7uH according to the debugging result
C2, C3 Electrolytic capacitor	Ripple voltage filtering	68-220uF/50V
C4 Ceramic capacitors	Ripple voltage filtering	1uF/50V

8. Test application

8.1. DC/DC Test circuit

Generally recommended capacitance: 47uF-100uF/50V

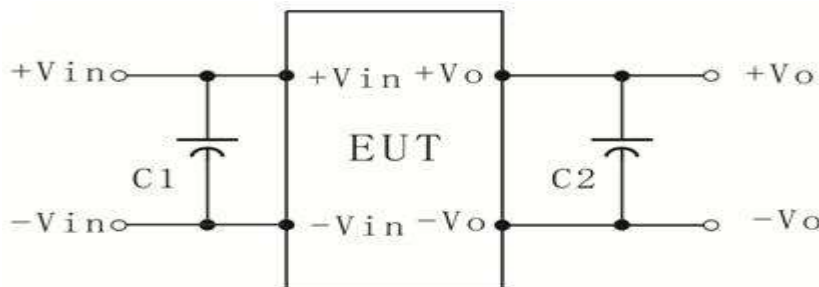

8.2. Ripple and noise test

(Twisted pair method, 20MHz bandwidth)

Testing method:

(1) Ripple noise is connected by 12# twisted pair. The oscilloscope bandwidth is set to 20MHz, 100M bandwidth probe, and 0.1uF polypropylene capacitor and 47uF high frequency low resistance electrolytic capacitor are connected in parallel on the probe end. The oscilloscope sampling uses Sample sampling mode.

(2) Schematic diagram of output ripple&noise test:

Connect the power input terminal to the input power supply terminal. The power output is connected to the electronic load through the fixture board. The test uses a 30cm ± 2 cm sampling line to sample directly from the power output port. The power line selects the insulated wire with the corresponding wire diameter according to the magnitude of the output current.

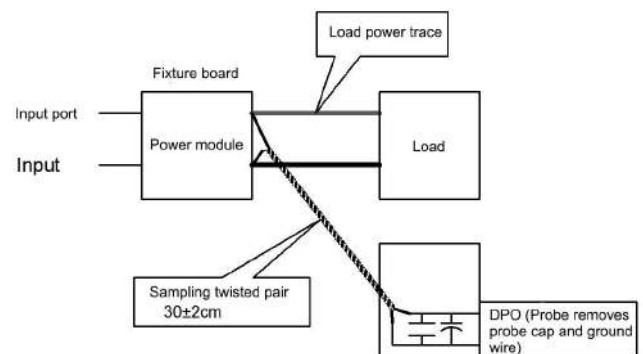

9. Marking, packaging, transportation, storage

9.1. Marking

9.1.1. Product mark

The product's unique bar code mark is attached to the appropriate position of the product to ensure traceability of the manufacturing date, product batch, etc. of each product. Its content meets the requirements of national standards and industry standards.

9.1.2. Packaging mark

The product packaging box is marked with the name of the manufacturer, the factory address, the zip code, the product model, the manufacturing date (year, month and day); It is marked with "upward", "moisture-proof" and "Be careful" transport signs, all of which comply with the provisions of GB 191.。

9.2. Packaging

The product is packaged in a special blister box, which has anti-vibration function and complies with GB 3873.

9.3. Transportation

The packaged product can be transported by any means of transport. There should be awnings during transportation, and there should be no severe vibration or impact.

9.4. Storage

Product storage should comply with the provisions of GB 3873.

10. Dimension and weight

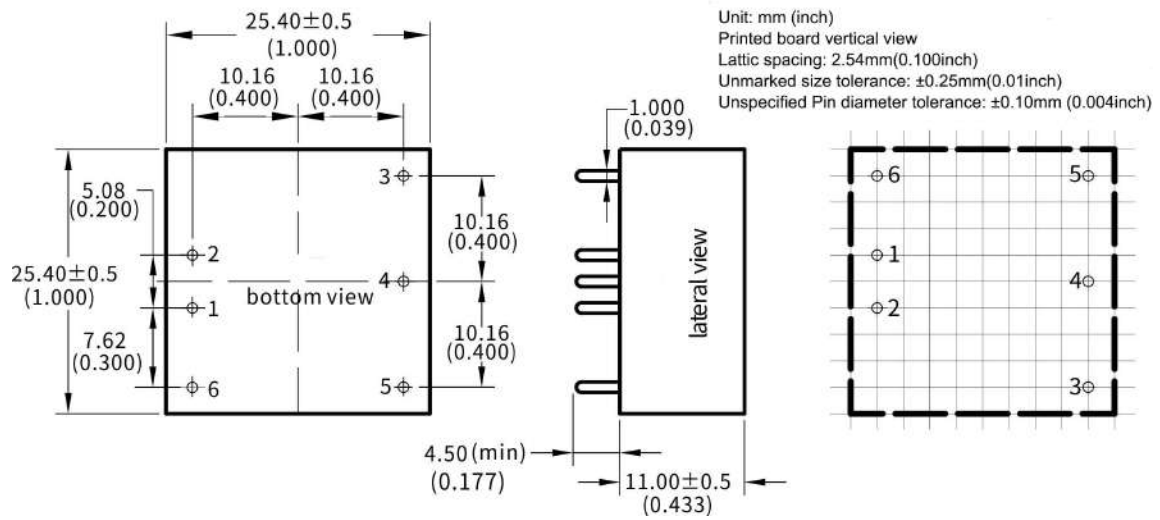

1	2	3	4	5	6
VIN-	VIN+	VO+	NP	GND	NC
Input negative	Input positive	Output positive	----	Output negative	---

The weight is about 11.1g