



Pyroelectric Infrared Radial Sensor

TYPE: D205B
NANYANG SENBA OPTICAL AND ELECTRONIC CO., LTD.

General Purpose and Omni-directional Quad Element Pyroelectric Infrared Radial Sensor

The pyroelectric infrared sensor detects infrared radiation on the basis of the characteristics that the self-polarization of pyroelectric material changes with temperature. Quad sensing elements are applied to suppress the interference resulting from circumstance temperature variation, to raise signal output and to be sensitive in all directions. This type sensor has the technical merits of both single and dual type. As a result, the operating stability of the sensor is greatly improved. It can be widely used in many applications such as in automatic light switch control, security systems, burglar alarms, visitor acknowledgement and intellectualized toy, etc., especially in the field of ceiling mount applications.

■ Standard Specifications and Dimensions

Recommended Model	D205B big window
Encapsulation Type	TO-5
IR Receiving Electrode	0.7×2.4mm, 4elements
Window Size	4.9×4.9mm
Spectral Response	5-14μm
Transmittance	≥75%
Output Signal[Vp-p]	≥5000mV
Sensitivity	≥4300V/W
Detectivity (D*)	$1.6 \times 10^8 \text{ cmHz}^{1/2}/\text{W}$
Noise[Vp-p]	<70mV
Output Balance	<10%
Offset Voltage	0.3-1.2V
Supply Voltage	3-15V
Operating Temp	-30-70°C
Storage Temp	-40-80°C
Field of View	
Equivalent Circuit	

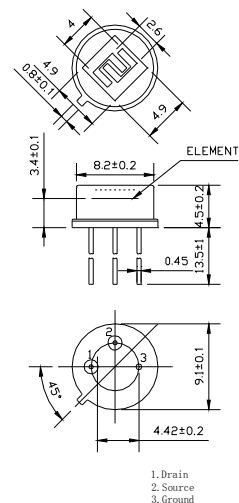

■ Test Method

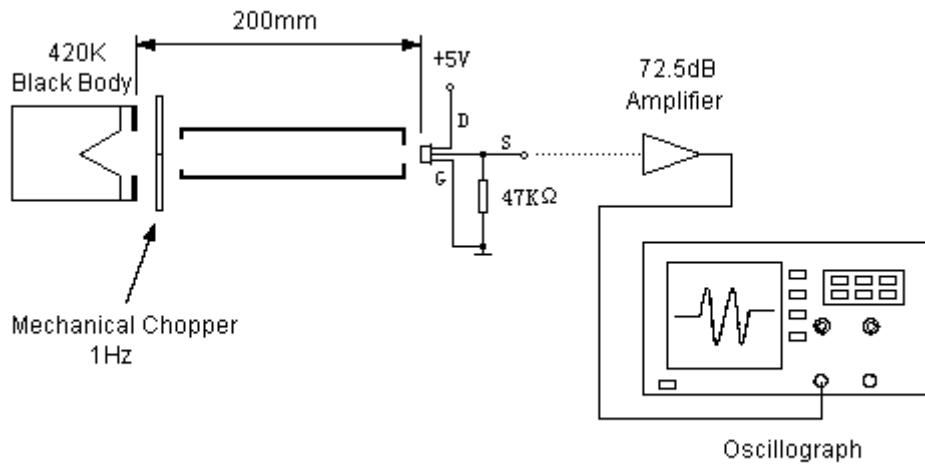

Measurement conditions

- ◆ Circumstance situation temperature 25°C
- ◆ Black-body temperature 420K (@147°C)
- ◆ Chopping frequency 1 Hz, 0.3~3.5Hz Δf
- ◆ 72.5 dB Amplifier

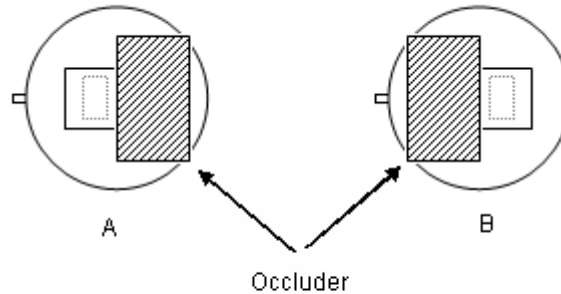

The sensitivity balance of sensor is calculated by measuring the sensitivity (signal output voltage) of each side and uses the formula as below:

$$\text{Balance} = |V_A - V_B| / (V_A + V_B) \times 100\%$$

V_A = Sensitivity of side A (mVp-p)

V_B = Sensitivity of side B (mVp-p)

■ Typical Application

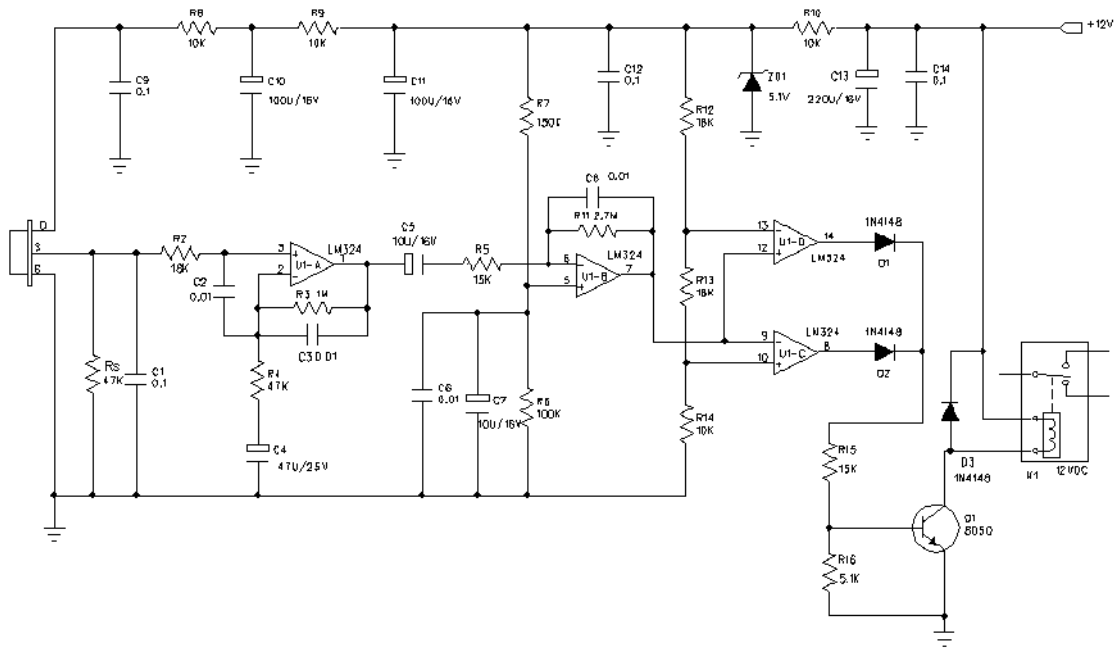

Notice:

U1A-D:LM324

Vdd:12V DC

Rs=47KΩ @ on an offset voltage

■ Spectral Response of Window Materials

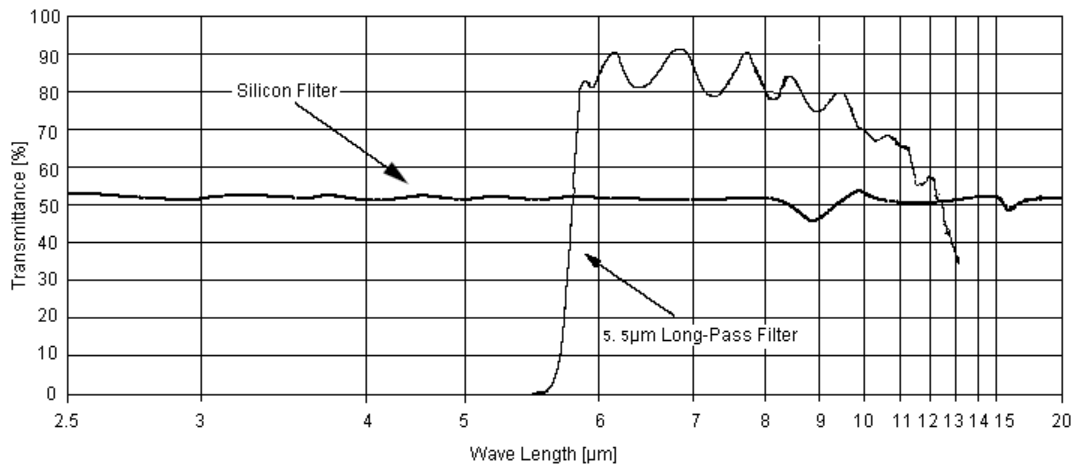

Notice:

The above curve is the typical figure of 5.5 μ m pass IR filter, the curve is the average value of IR transmittance, the window's substrate is vacuum-coated with semiconductor material.

■ Fresnel Lens for Human Body Detection

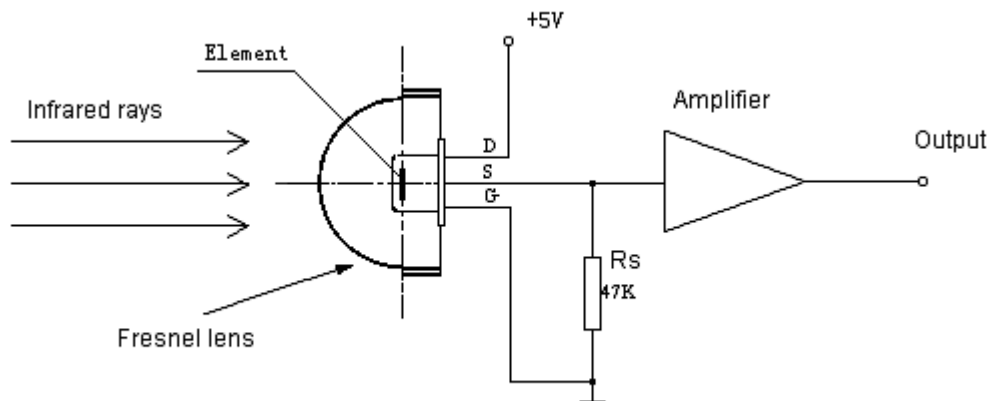
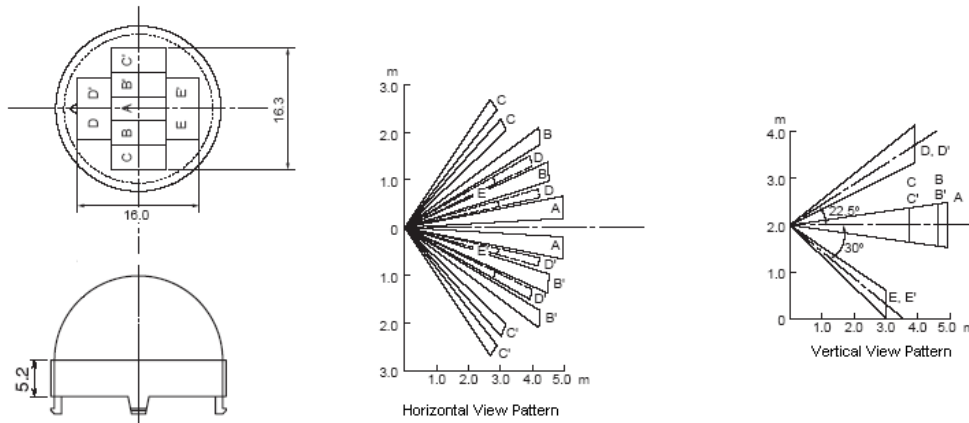

■ Directions for Use

- Pay attention to the mounting direction of the sensor's element and the size of element ichnography. Combining with focus of Fresnel lens can achieve a optimal optics design.
- The ex-factory parameter of sensor is gained by testing in the condition of standard Black Body and the relevant circuit after one minute steadying-time.
- The detecting distance of sensor is a multidimensional function, consisting of ambient temperature, temperature of moving target, target distance of Fresnel Lens', ambient humidity, amplifier gain and comparison voltage.
- The welding shall be made at 4mm above as per the recommendation for lead wire of sensor seat, and the welding should be completed in the shortest possible time.
- Do not touch the window by hand and the hard things directly.
- Strong shake and static should be avoided.
- This products are packed with the environmental protection material, and the sensors' surface has been covered specially with OHK anti-erode material, 100pcs per small package, 3000pcs per large package.



NANYANG SENBA OPTICAL AND ELECTRONIC CO. LTD. SHENZHEN BRANCH

Add : 2nd Floor, #D Building, Huawan Industry Zone, Gushu, Xixiang Street ,
Bao'an Dist., ShenZhen City China

Website: www.nysenba.com

E-mail : lily@sbcds.com.cn

Tel : 86-755-82591786

Fax : 86-755-82591842