

REV.	DESCRIPTION OF REVISIONS	APPR.	DRAW.	RELEASE	DATE
X1	NEW REVISION				Zoey Mar.04.2011
X2					

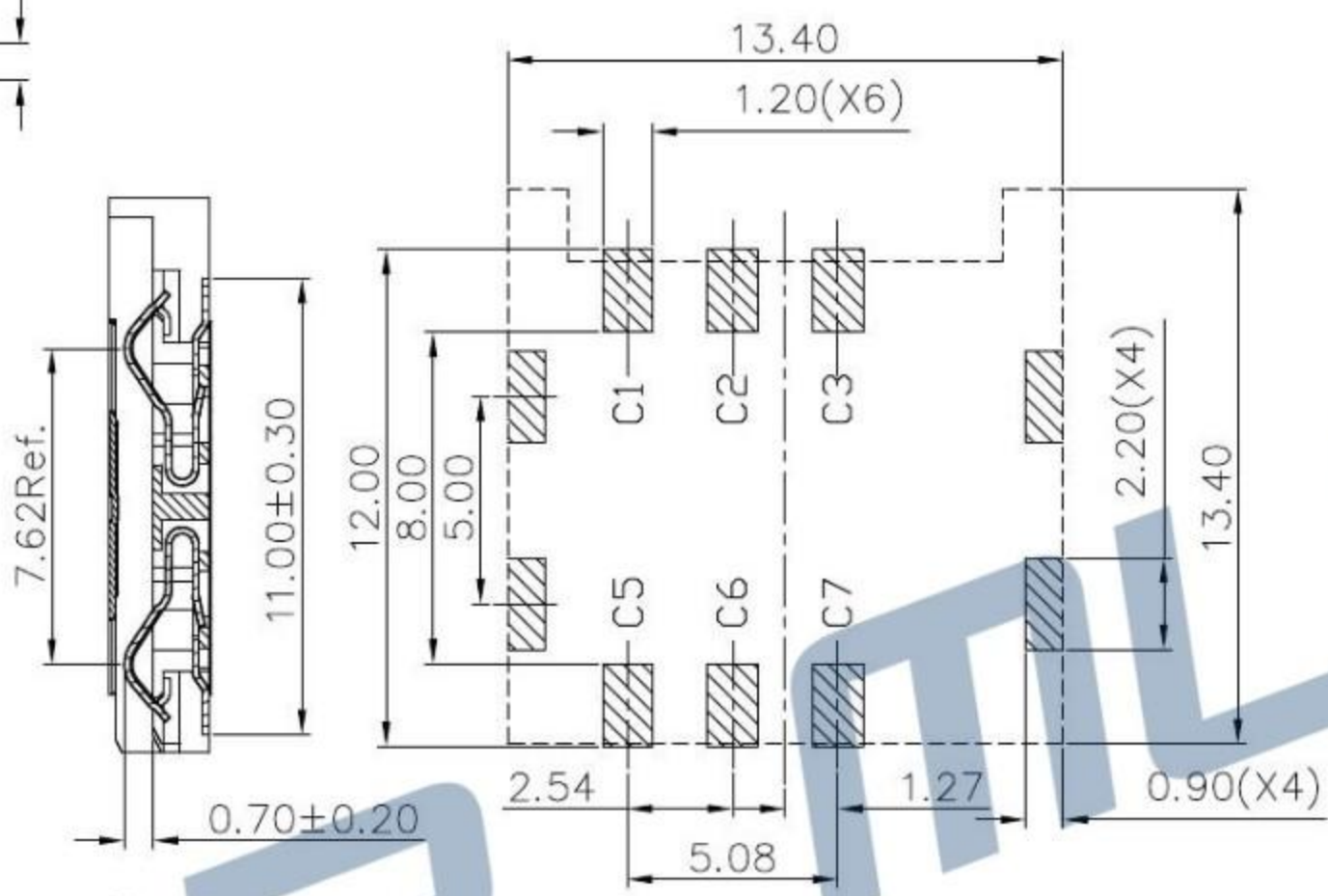
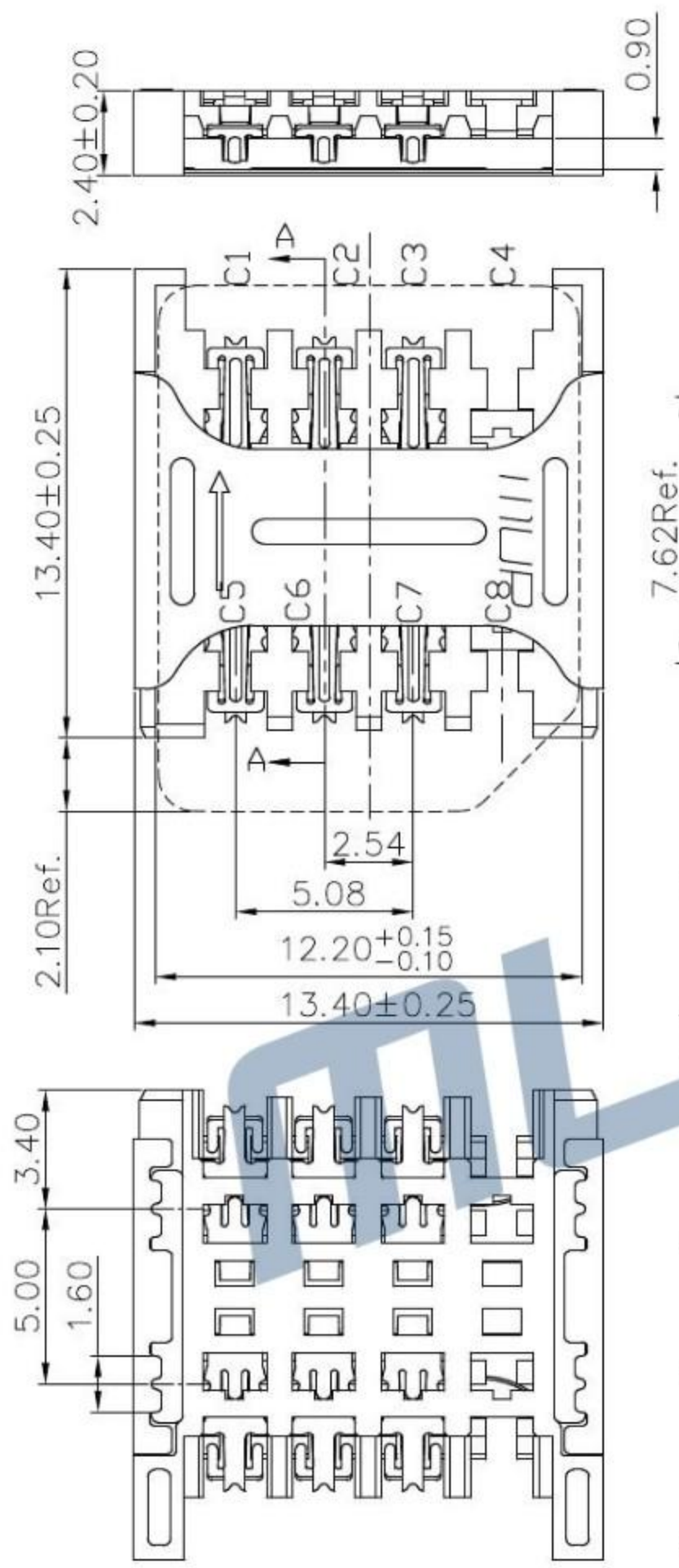

SECTION A-A

RECOMMENDED P.C.B LAYOUT
COMPONENT SIDE(TOLERANCE ±0.05)

TECHNICAL CHARACTERISTICS

- General Characteristics
 - Dimensions: 13.40LX13.40WX2.40H mm
 - Weight: Approx 0.40±0.1g
 - Durability: 5,000 cycles min.
- Electrical Characteristics
 - Contact resistance: 50mΩ typical, 100mΩ max
 - Insulation resistance: >1000MΩ/500V DC
- Solderability
 - Vapor phase: 215°C, 30sec. Max
 - IR reflow: 250°C, 5sec. Max
 - Manual soldering: 370°C, 3sec. Max
- Environmental Characteristics
 - Operating temperature: -40°C~+85°C
 - Operating humidity: 10%~+95%RH

ITEM	PART NAME	Q'TY	MATERIAL	FINISH
1	BASE	1	Hi-temp Thermoplastic	Black UL94V-0
2	DATA CONTACT	6	Copper Alloy	Contact area: Gold plated
3	SHELL	1	Stainless steel	SMT area: Gold plated

Unless otherwise specified, other tolerance are:

X ±0.35	X* ±5°	NAME: Micro-SIM Card Connector
X.X ±0.25	X.X* ±4°	
X.XX ±0.15	X.XX* ±3°	
X.XXX ±0.10	X.XXX* ±2°	

MUP[®] MUP INDUSTRIAL CO.,LTD.

MODEL NO: **MUP-C790-21**

TYPE: **H2.40 mm 6Pin**

PROJ.	UNIT	SCALE	DRAWN	Zoey Mar.04.2011	DWG NO.:
	MM	1:1	CHECKED	Sean Mar.04.2011	DWG-MUP-C790-21
CUSTOMER DRAWING			APPROVAL	Simon Mar.04.2011	SHEET
					1/1
					REVISION
					X1

