

Features

- 1 Channel H-Bridge Motor Driver: Low MOSFET On-resistance: 0.3Ω (HS+LS)
- Wide V_{DD} Input Voltage Range of 2.5V to 5.5V
- Maximum Motor Power Supply V_M : Up to 15V
- Maximum 3.0A Motor Peak Current
- Four Operation Modes: Forward, Reverse, Brake and Standby
- Sleep Period Activation Mechanism
 - ♦ HT7K1311: Automatically entering Sleep Period by resetting both IN1 and IN2 pins for over 10ms
 - ♦ HT7K1312: Immediately entering Sleep Period controlled by EN pin
- Low Sleep Current $< 0.1\mu\text{A}$
- Split Controller and Motor Power Supplies: V_{DD} and V_M
- Isolation Motor Current Sensing Pin: PGND for HT7K1311 only
- Up to 200kHz PWM Input Control Operation
- Internal Pull Down Resistor
 - ♦ IN1/IN2: $135\text{k}\Omega$ for HT7K1311/HT7K1312
 - ♦ EN: $12\text{k}\Omega$ for HT7K1312 only
- Protection Features:
 - ♦ V_{DD} Under Voltage Lock-Out
 - ♦ Over Current Protection
 - ♦ Thermal Shutdown Protection
 - ♦ Output Short Circuit Protection
- Package Type
 - ♦ HT7K1311: 8-pin SOP-EP
 - ♦ HT7K1312: 8-pin DFN
- Operation Temperature Range: -40°C to $+85^\circ\text{C}$

Applications

- Electric locks, toys, portable printers

General Description

The HT7K1311/HT7K1312 is a 1-channel H-bridge driver with a maximum motor peak current of 3.0A. Its outstanding low on-resistance characteristic results in excellent output efficiency which is a major advantage in battery powered systems. A simple two input control pin structure is used to provide four control modes: Forward, Reverse, Brake and Standby modes. With a PWM input control frequency of up to 200kHz, accurate speed control can be implemented for a wide variety of applications. A full range of protection functions are integrated including OCP, OSP and OTP to prevent device damage even if the motor stalls or experiences a short circuit in critical operating environments. As the automatic Sleep Period activation mechanism uses the same mode control pins, an additional extra shutdown signal is not required for HT7K1311. However, for HT7K1312 an extra enable pin, EN, directly determines whether the device enters the Sleep Period. In addition, a low $0.1\mu\text{A}$ Sleep Period current ensures long battery life. The device also includes separate power supplies for the control circuits and the motor power supply and also includes a current sensing pin to allow the system to measure the motor current using an external resistor.

Typical Application Circuit

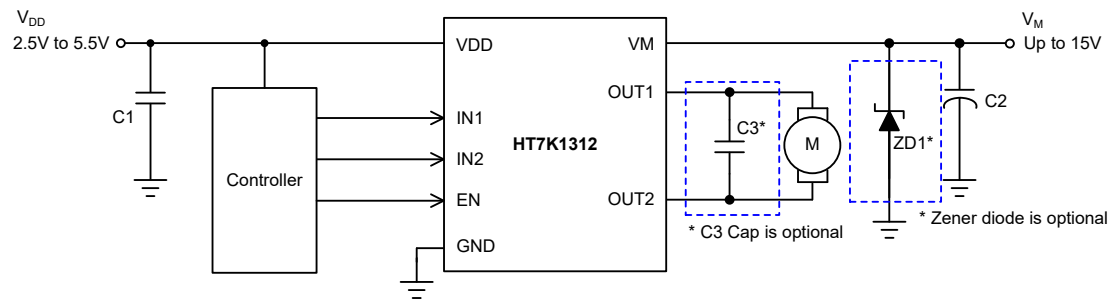
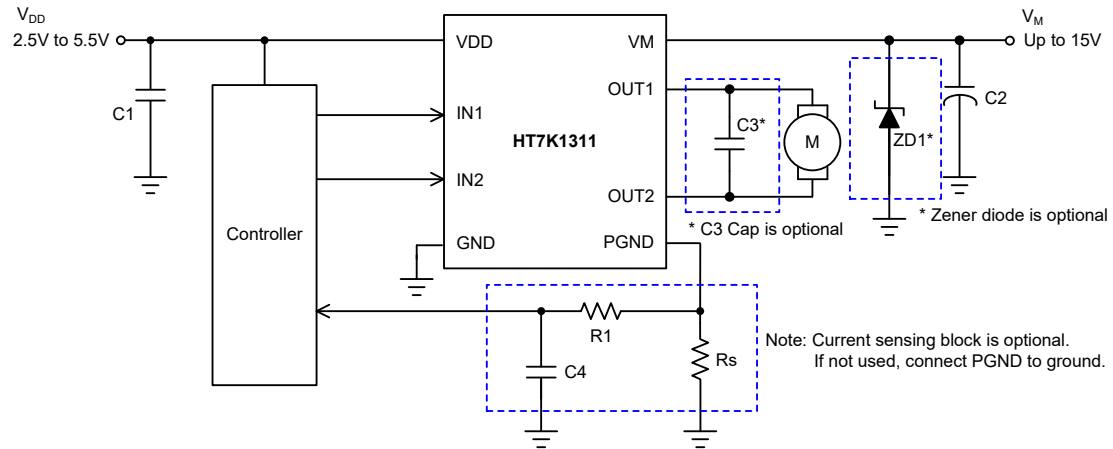

Functional Block Diagram

HT7K1311

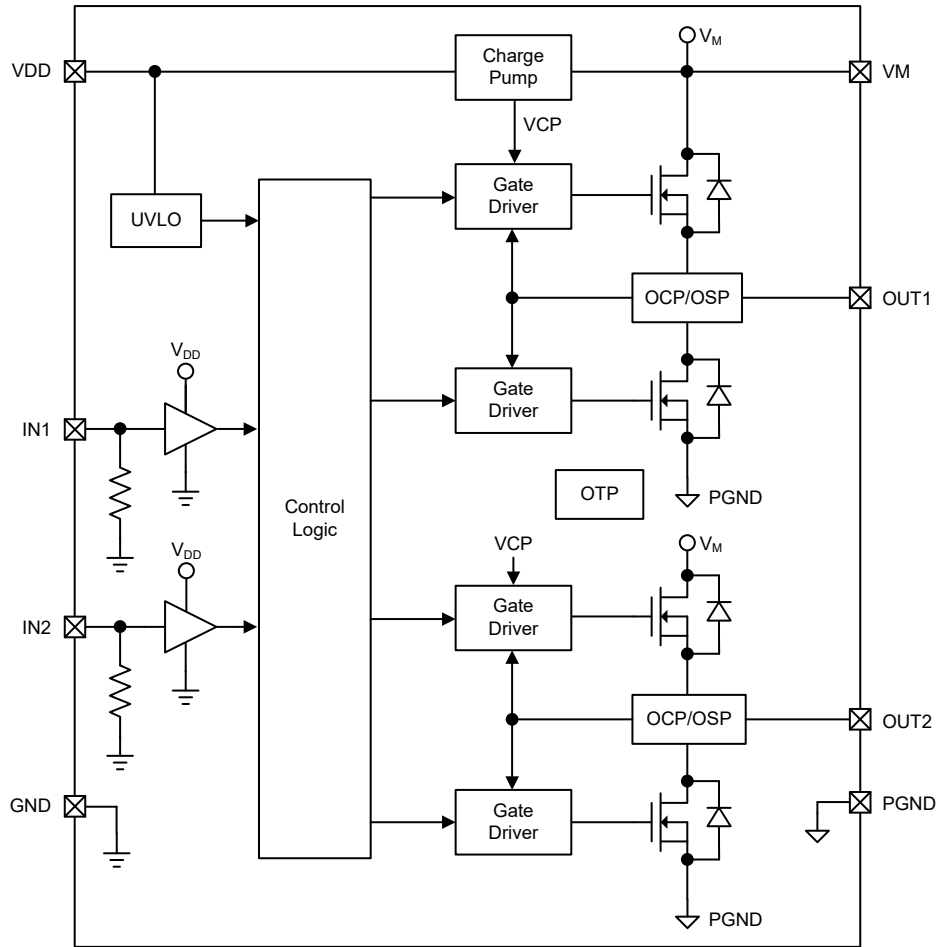

HT7K1312

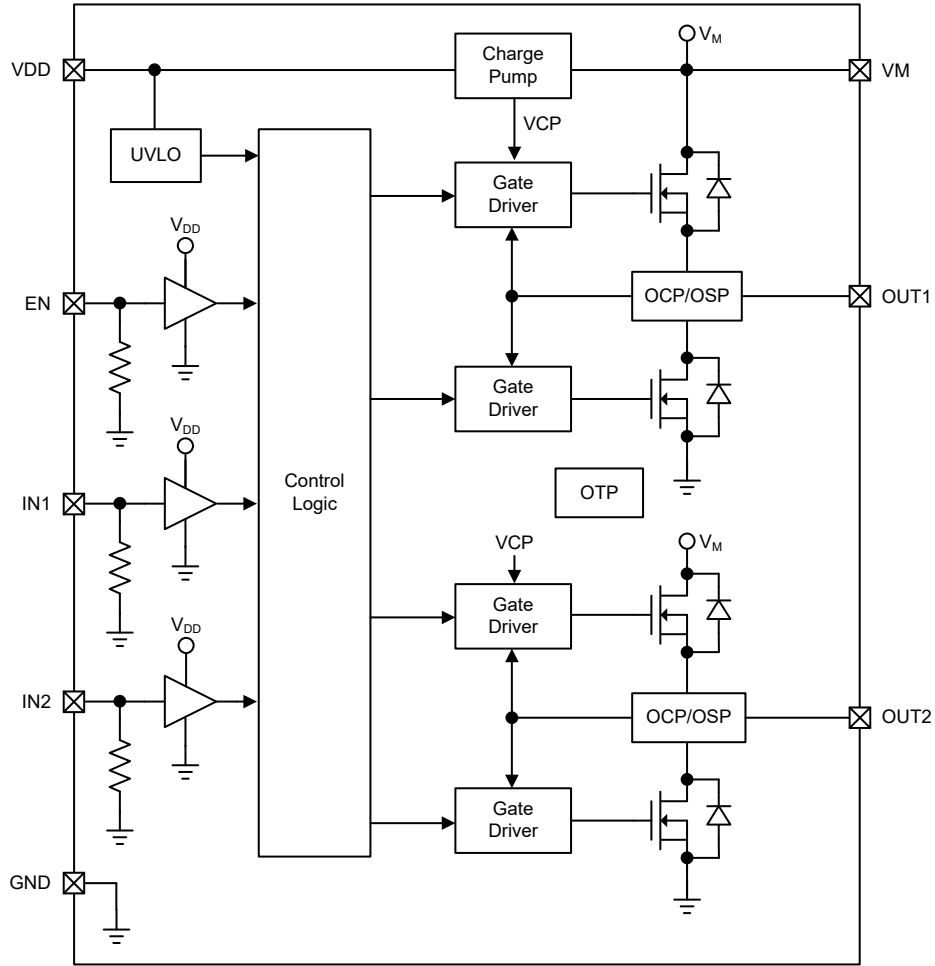

Pin Assignment

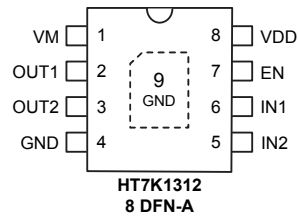
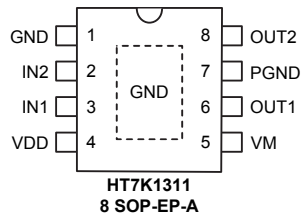

Pin Description

HT7K1311

Pin Order	Name	Type	Pin Discription
1	GND	G	Analog Ground
2	IN2	I	Control Input 2 135kΩ pull down resistor internally
3	IN1	I	Control Input 1 135kΩ pull down resistor internally
4	VDD	P	IC Power supply
5	VM	P	Motor Power supply
6	OUT1	O	H-Bridge Output 1
7	PGND	G	Motor Current Sensing Terminal Connect via a sensing resistor to GND. If it is not necessary to sense the motor current, the PGND line should be directly connected to GND.
8	OUT2	O	H-Bridge Output 2
EP	GND	G	Thermal Enhance Pad. Connected to GND

Note: I: Input; O: Output; P: Power; G: Ground.

HT7K1312

Pin Order	Name	Type	Pin Discription
1	VM	P	Motor Power supply
2	OUT1	O	H-Bridge Output 1
3	OUT2	O	H-Bridge Output 2
4	GND	G	Analog Ground
5	IN2	I	Control Input 2 135kΩ pull down resistor internally
6	IN1	I	Control Input 1 135kΩ pull down resistor internally
7	EN	I	Chip Enable Input 12kΩ pull down resistor internally. When EN='0', HT7K1312 enters Sleep Period.
8	VDD	P	IC Power supply
EP	GND	G	Thermal Enhance Pad. Connected to GND

Note: I: Input; O: Output; P: Power; G: Ground.

Absolute Maximum Ratings

Parameter	Value	Unit	
V _{DD}	-0.3 to +6.0	V	
V _M , OUT1, OUT2	-0.3 to +20	V	
IN1, IN2	-0.3 to (V _{DD} +0.3)	V	
PGND	±0.7	V	
Operating Temperature Range	-40 to +85	°C	
Maximum Junction Temperature	+150	°C	
Storage Temperature Range	-65 to +160	°C	
Lead Temperature (Soldering 10sec)	+260	°C	
ESD Susceptibility	Human Body Model	±5000	V
	Machine Model	±400	V
Junction-to-Ambient Thermal Resistance, θ_{JA}	8SOP-EP/8DFN	125	°C/W

Recommended Operating Ratings

Parameter	Value	Unit
V _{DD}	2.5 to 5.5	V
V _{M(MAX)}	15	V
PGND _(MAX)	±0.5	V
I _{OUT(PEAK)}	3.0	A

Note that the Absolute Maximum Ratings indicate limitations beyond which damage to the device may occur. Recommended Operating Ratings indicate conditions for which the device is intended to be functional, but do not guarantee specified performance limits.

Electrical Characteristics

V_{DD}=5V, V_M=15V and T_a=+25 °C, unless otherwise specified

Symbol	Parameter	Test Condition	Min.	Typ.	Max.	Unit
Power Supply						
V _{DD}	Supply Voltage	—	2.5	—	5.5	V
I _{DD}	Supply Operation Current	PWM=25kHz, OUT1 and OUT2 open	—	0.45	1.00	mA
I _{DD(STB)}	Supply Standby Current	IN1=IN2="0", Standby mode	—	550	800	µA
I _{DD(SLP)}	Supply Sleep Current	IN1=IN2="0" or "1", Sleep Period	—	—	0.1	µA
V _M	Motor Power Supply	—	2.5	—	15	V
I _M	V _M Operation Current	PWM=25kHz, no load	—	0.85	1.00	mA
I _{M(STB)}	V _M Standby Current	IN1=IN2="0", Standby mode	—	950	1100	µA
H-Bridge Driver						
R _{ON}	HS+LS FET On-resistance ⁽¹⁾	V _{DD} =3.3V, I _{OUT} =800mA	—	0.3	0.4	Ω
V _{CLAMP}	Clamp Diode Voltage	I=500mA (HS and LS)	—	0.8	—	V
I _{HS(OFF)}	HS MOSFET Leakage Current	IN1=IN2="0", V _M =15V, V _{OUT} =0V, measure I (V _M)	—	—	0.1	µA
t _{r(OUT)}	Output Rise Time	R _L =20Ω, 10% to 90% (Figure1)	—	100	—	ns
t _{f(OUT)}	Output Fall Time	R _L =20Ω, 90% to 10% (Figure1)	—	100	—	ns
Control Logic						
V _{IL}	Input Logic Low Voltage	V _{DD} =5.0V	—	—	0.8	V
		V _{DD} =2.5V	—	—	0.4	V
V _{IH}	Input Logic High Voltage	V _{DD} =5.0V	2	—	—	V
		V _{DD} =2.5V	1	—	—	V

Symbol	Parameter	Test Condition	Min.	Typ.	Max.	Unit
V _{HYS}	Input Logic Hysteresis	—	—	0.1	—	V
t _{P1}	IN-to-OUT Propagation Delay (Figure 1)	R _L =20Ω, INx to OUTx (high-Z to high/low)	—	100	—	ns
t _{P2}		R _L =20Ω, INx to OUTx (high/low to high-Z)	—	100	—	ns
t _{P3}		R _L =20Ω, INx to OUTx	—	100	—	ns
t _{P4}		R _L =20Ω, INx to OUTx	—	100	—	ns
t _{SLPEN}	Sleep Period Entry Time	IN1=IN2="0" or "1" until charge pump switches off (Figure 2 for HT7K1311 only)	—	10	—	ms
f _{PWM}	Input PWM Frequency	Internal charge pump activates	—	—	200	kHz
R _{PD}	Input Pull Down Resistance	IN1 and IN2	—	135	—	kΩ
		EN for HT7K1312 only	—	12	—	kΩ
Charge Pump						
t _{CP_ON}	Charge Pump on Time	Charge pump activates time (Figure 2, 3)	—	10	—	ms
Protection						
V _{UVLO+}	V _{DD} Turn on Level	V _{DD} rises	—	—	2.5	V
V _{UVLO-}	V _{DD} Turn off Level	V _{DD} falls	1.8	—	—	V
I _{OCP}	Over Current Threshold	With deglitch time, t _{DEG}	2.5	3.0	3.5	A
t _{DEG}	Over Current Deglitch Time	(Figure 4)	—	2	—	μs
t _{RETRY}	Over Current Retry Time ⁽³⁾	(Figure 4 & 5 & 6)	—	1	—	ms
I _{OSP}	Short Circuit Threshold ⁽²⁾	Without deglitch time (Figure 5)	—	4.5	—	A
T _{SHD}	Thermal Shutdown Threshold	—	—	155	—	°C
T _{REC}	Thermal Recovery Temperature	—	—	120	—	°C

Note: 1. HS means High Side and LS means Low Side.

- The devices provide full short circuit protection for the OUTx-to-ground, OUTx-to-power or OUT1-to-OUT2 path.
- The retry mechanism is only active in Forward and Reverse mode.

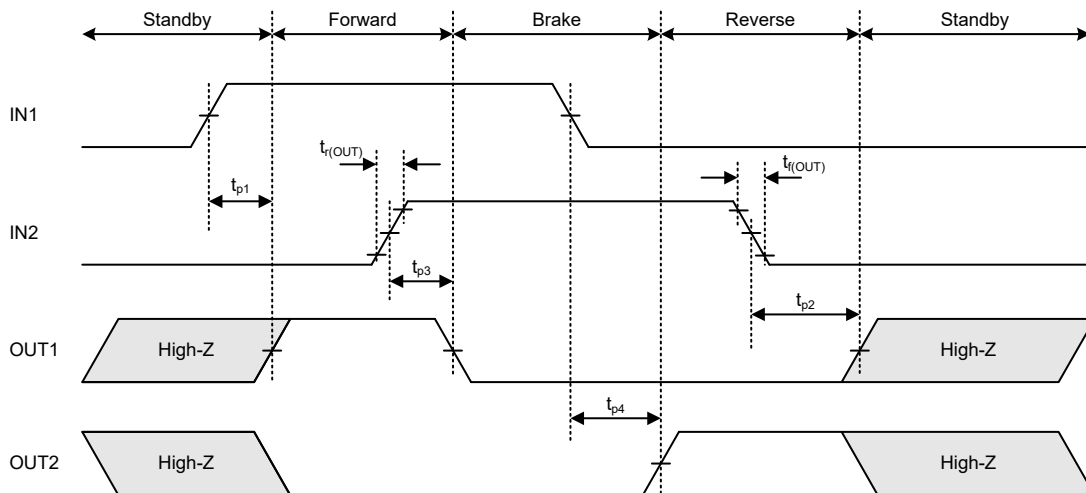

Figure 1. HT7K1311 and HT7K1312 Operation Mode Control Logic in Active Period

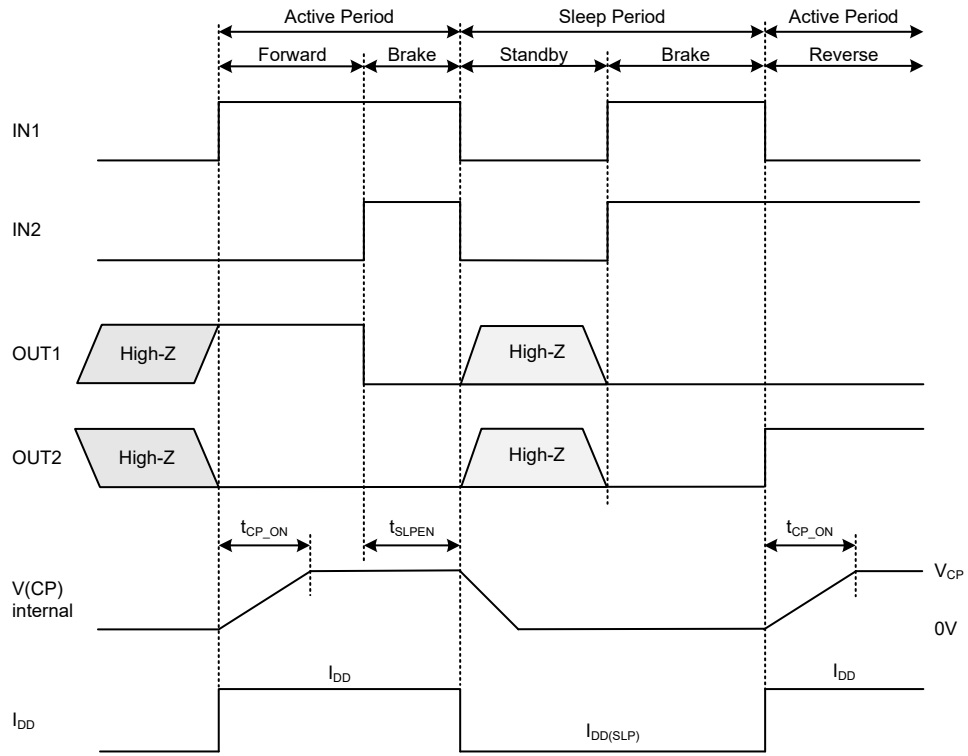

Figure 2. HT7K1311 Operation Mode Control Timing Diagram

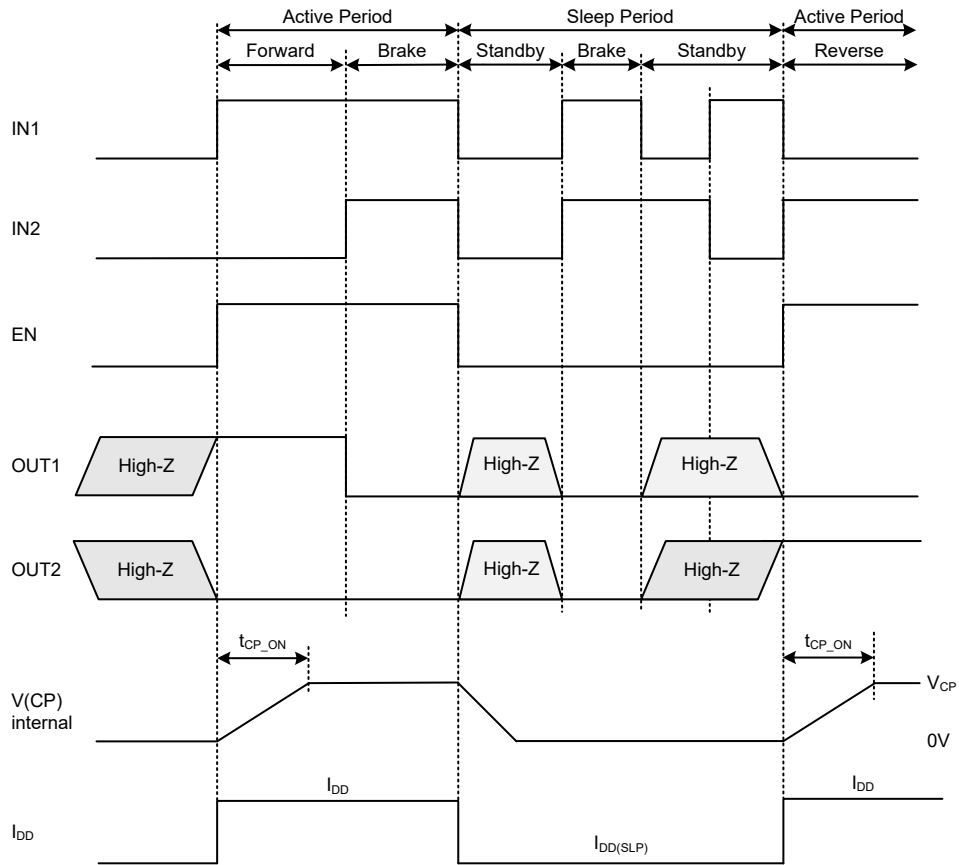

Figure 3. HT7K1312 Operation Mode Control Timing Diagram

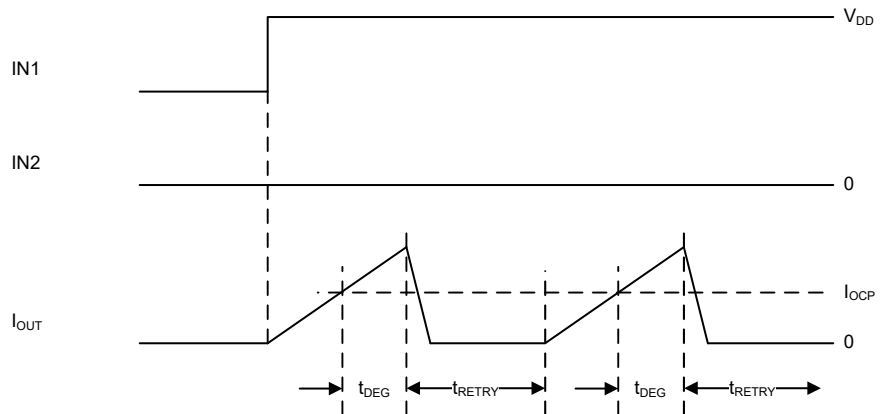

Figure 4. HT7K1311/HT7K1312 OCP Reaction

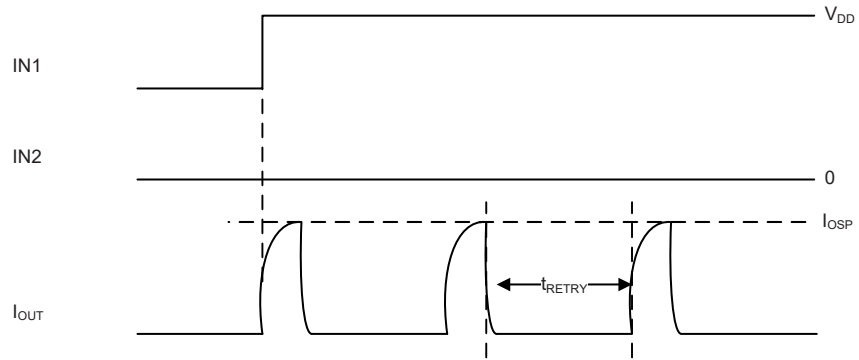

Figure 5. HT7K1311/HT7K1312 OSP Reaction

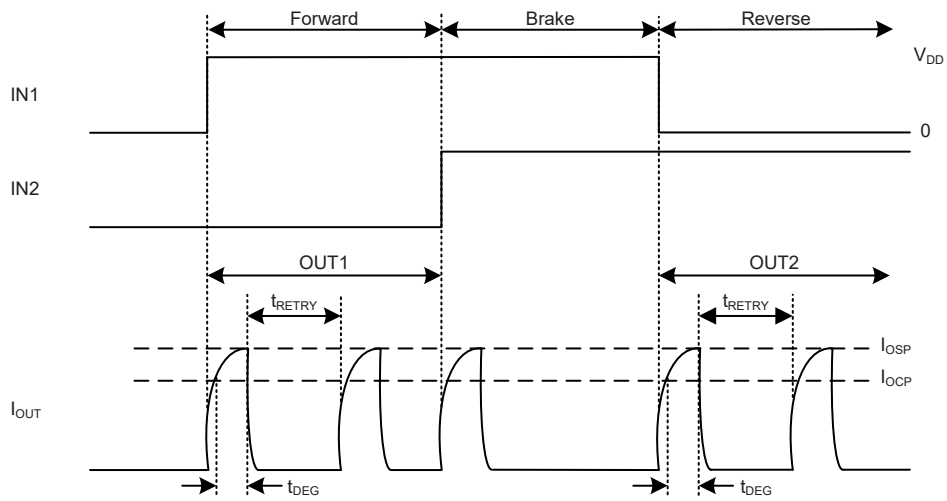
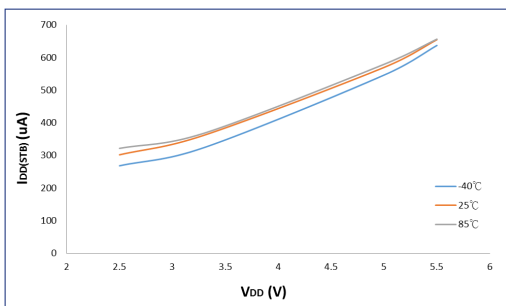
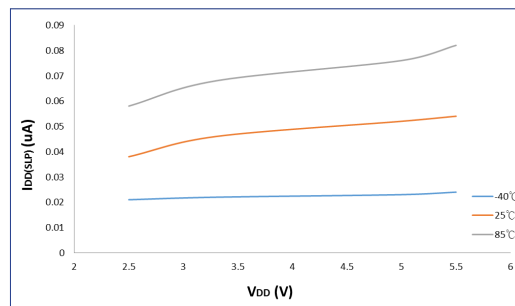

Figure 6. HT7K1311/HT7K1312 Retry Reaction

Typical Performance Characteristics



$I_{DD(STB)}$ VS. V_{DD}



$I_{DD(SLP)}$ VS. V_{DD}

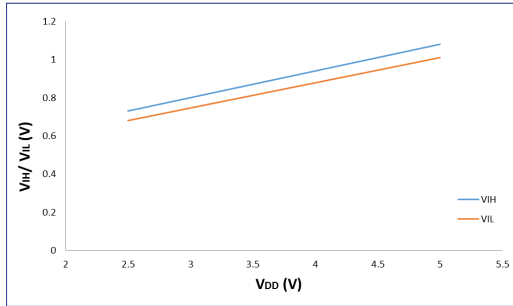

V_{IH}/V_{IL} vs. V_{DD}

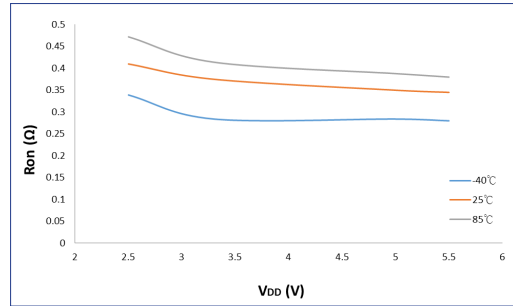

HT7K1311 R_{ON} vs. V_{DD} (-40°C, 25°C, 85°C)

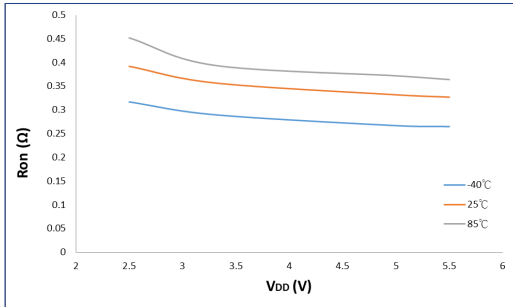

HT7K1312 R_{ON} vs. V_{DD} (-40°C, 25°C, 85°C)

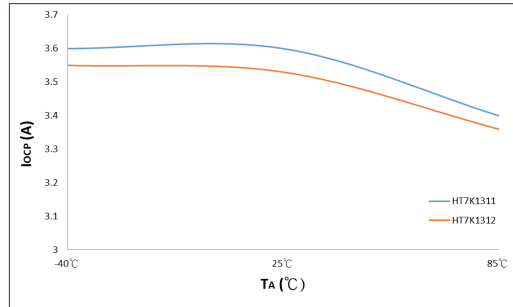

I_{OCP} vs. Temperature

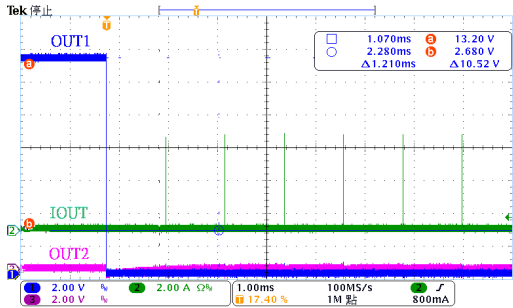

Short Protection Reaction

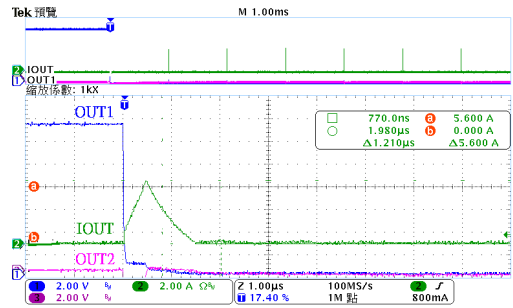

Short Protection Reaction (Zoom-in)

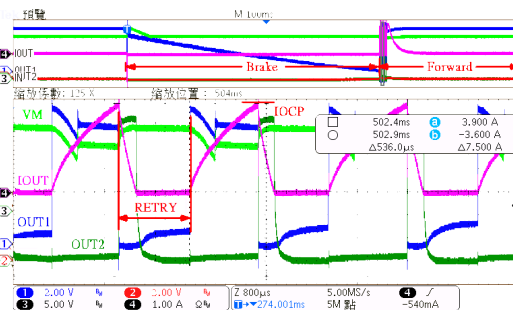

Forward Mode Active Retry Reaction

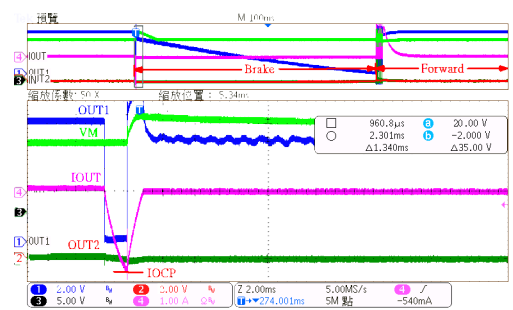

Brake Mode OCP Reaction

Functional Description

HT7K1311/HT7K1312 Overview

The HT7K1311/HT7K1312 is a 1-ch H-bridge driver that can drive DC brush motors or solenoids. Due to the 4 internal very low on-resistance power MOSFETs which have parallel spark killer diodes and the excellent heat dissipating 8-pin SOP-EP and 8-pin DFN packages, the HT7K1311/HT7K1312 motor driver has a high efficiency motor driving capability, reduced external components and outstanding thermal performance. Separate controller and motor power supplies allow for simplified system power domain design. The isolated motor current sensing pin, PGND, is only available for the HT7K1311 and is

designed to detect the motor current by connecting a resistor from this pin to ground. The device also includes a full range of protection functions including over-current and over-temperature to prevent the possibility of burn-out occurring even if the motor stalls or if the output pins are shorted to each other.

H-Bridge Control

According to the IN1 and IN2 pin states the device will generate four H-bridge output states: Standby, Forward, Reverse and Brake. The operation truth tables of HT7K1311 and HT7K1312 in Active Period are shown in Table 1 and Table 3. The operation truth table of HT7K1311 and HT7K1312 in Sleep Period are shown in Table 2 and Table 4.

IN1	IN2	OUT1	OUT2	Operation Mode	H-Bridge Status			
					M1	M2	M3	M4
0	0	Z	Z	Standby	OFF	OFF	OFF	OFF
0	1	L	H	Reverse	OFF	ON	ON	OFF
1	0	H	L	Forward	ON	OFF	OFF	ON
1	1	L	L	Brake	OFF	ON	OFF	ON

Table 1. HT7K1311 Operation True Table in Active Period

IN1	IN2	OUT1	OUT2	Operation Mode	H-Bridge Status			
					M1	M2	M3	M4
0	0	Z	Z	Standby	OFF	OFF	OFF	OFF
1	1	L	L	Brake	OFF	ON	OFF	ON

Table 2. HT7K1311 Operation True Table in Sleep Period

EN	IN1	IN2	OUT1	OUT2	Operation Mode	H-Bridge Status			
						M1	M2	M3	M4
1	0	0	Z	Z	Standby	OFF	OFF	OFF	OFF
1	0	1	L	H	Reverse	OFF	ON	ON	OFF
1	1	0	H	L	Forward	ON	OFF	OFF	ON
1	1	1	L	L	Brake	OFF	ON	OFF	ON

Table 3. HT7K1312 Operation True Table in Active Period

EN	IN1	IN2	OUT1	OUT2	Operation Mode	H-Bridge Status			
						M1	M2	M3	M4
0	0	0	Z	Z	Standby	OFF	OFF	OFF	OFF
0	0	1	Z	Z	Standby	OFF	OFF	OFF	OFF
0	1	0	Z	Z	Standby	OFF	OFF	OFF	OFF
0	1	1	L	L	Brake	OFF	ON	OFF	ON

Table 4. HT7K1312 Operation True Table in Sleep Period

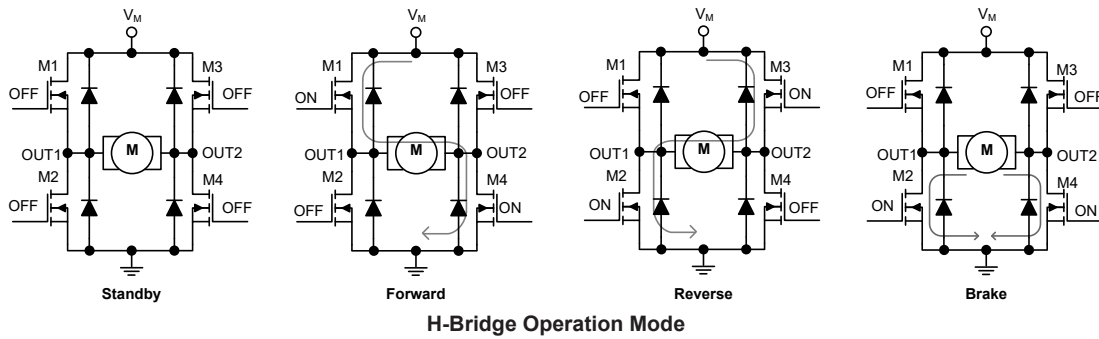

Active Period and Sleep Period

When the Standby or Brake mode continuously exceeds over 10ms, the HT7K1311 will enter the Sleep Period. At this time, the Standby or Brake mode still works in the Sleep Period as shown in Table 2. Change the operation mode to Forward or Reverse will go back to the Active Period.

In the Sleep Period, all functional blocks are turned off to reduce the current consumption to an ultra-low value of less than 0.1 μ A (max). At this time, switching IN1/IN2 to Brake or Standby configuration only affects the output – OUT1/OUT2, the driver remains in the Sleep Period (Figure7). Since all functional blocks are turned off, the Standby and Brake mode outputs are not protected. When an IN1 or IN2 pin is set to “High”, the device will exit from the Sleep Period. However, the HT7K1312 controls the Active/Sleep Period entry via the EN pin directly (Figure 8).

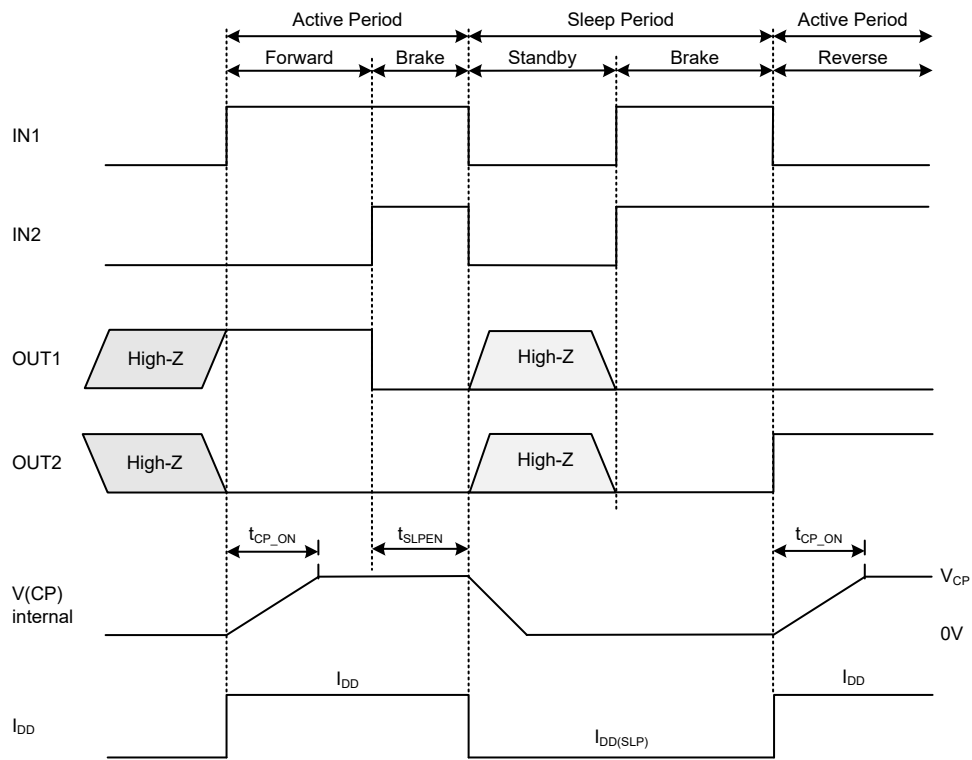

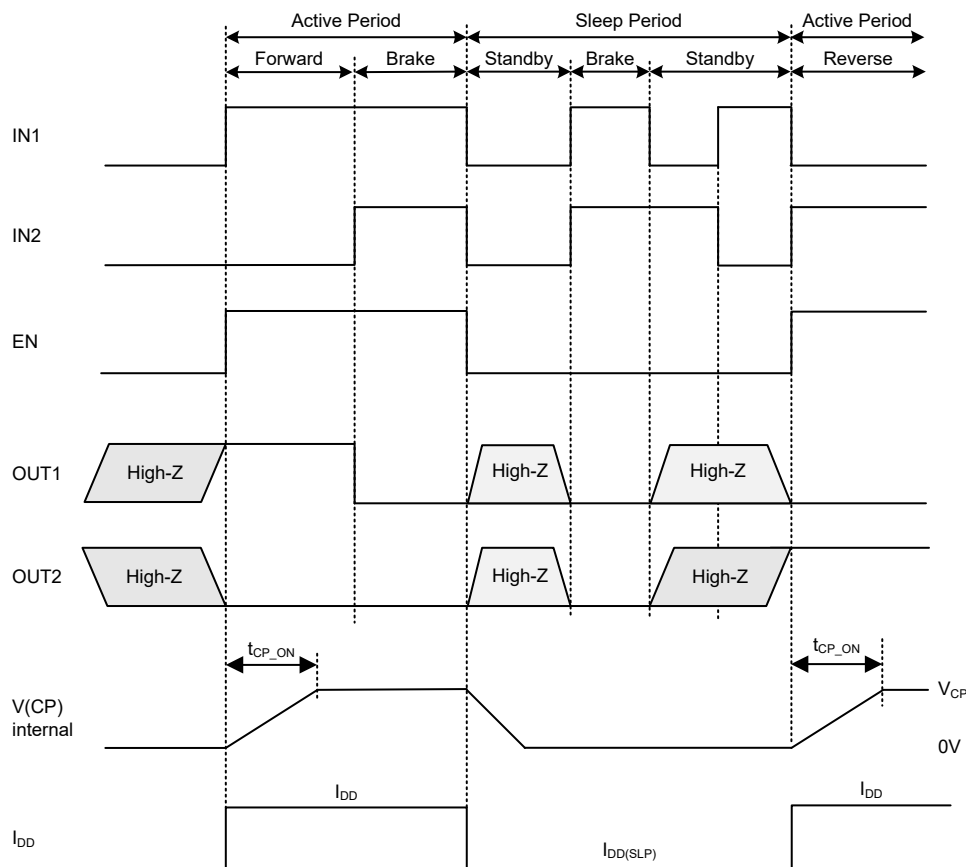

Figure 8. HT7K1312 Timing Diagram

V_{DD} Under Voltage Lock-Out

In order to avoid an H-bridge metastable output condition when powered-on or with a low battery voltage, an under voltage lockout function is integrated within the device. During the power-on period, the H-bridge outputs will remain in high impedance states and the control inputs are ignored when V_{DD} is lower than V_{UVLO+} . The H-bridge outputs are only controlled by inputs when V_{DD} is higher than V_{UVLO+} . The device will be locked again when V_{DD} falls to a voltage level lower than V_{UVLO-} .

Over Current Protection – OCP

Each device includes a fully integrated over current protection function within each of the internal power MOSFETs. When the motor current exceeds the over current protection threshold, I_{OCP} , exceeding a de-glitch time, t_{DEG} , all power MOSFETs will be turned off immediately. After the retry time times out, the device will release the protection activation and allow normal operation to resume. The retry mechanism is only available in Forward and Reverse modes.

Output Short-Circuit Protection – OSP

Each device provides full output protection for conditions such as an output pin short to ground, to the motor supply or to each other. The device detects the current through each power MOSFETs and compares it with the output short circuit protection threshold, I_{OSP} , without a de-glitch time. The current threshold I_{OSP} is internally set to 1.5 times the I_{OCP} . When an OSP condition occurs, the device will turn off all power MOSFETs and keep checking the output status every retry time, t_{RETRY} , until the fault is removed. The retry mechanism is only available in Forward and Reverse modes.

Over Temperature Protection – OTP

If the die temperature exceeds the internal limit threshold, T_{SHD} , the device will turn off all power MOSFETs until the temperature decreases to a specific level less than the recovery temperature, T_{REC} .

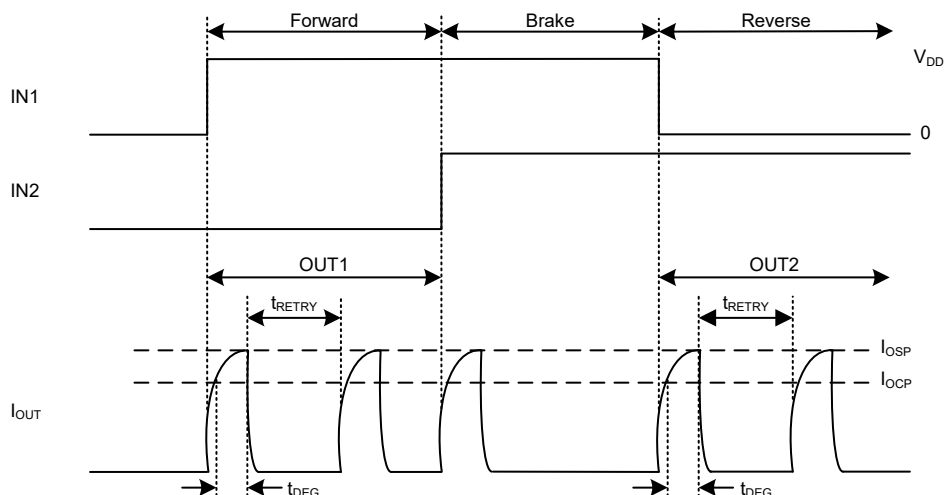

Figure 9. Retry Mechanism

The retry mechanism entry and release conditions are shown as follows.

Protection Type	Retry Entry Condition	Functional Mode				Retry Release Condition
		Forward/Reverse	Brake	Standby	Sleep	
OCP	$I_{OCP} > 3.0A$	O	—	—	—	$I_{OCP} < 3.0A$
OSP	OUTx-to-ground, OUTx-to-power or OUT1-to-OUT2 path	O	—	—	—	Short circuit fault is removed

Table 5. Retry Mechanism Conditions

The protection function entry and release conditions are shown as follows.

Protection Type	Protection Entry Condition	Functional Mode				Protection Release Condition
		Forward/Reverse	Brake	Standby	Sleep	
UVLO	$V_{IN} < 1.8V$	—	O	—	—	$V_{IN} > 2.5V$
OCP	$I_{OCP} > 3.0A$	O	O	—	—	$I_{OCP} < 3.0A$
OSP	OUTx-to-ground, OUTx-to-power or OUT1-to-OUT2 path	O	O	—	—	Short circuit fault is removed
OTP	$T_J > 155^{\circ}C$	O	O	O	—	$T_J < 120^{\circ}C$

Table 6. Protection Function Conditions

Motor Current Sensing – HT7K1311

The HT7K1311 device can be used to implement a motor current sensing function by connecting an external resistor from PGND to GND. The PGND voltage is recommended to be kept lower than 0.5V to avoid turning on the protection diodes on the input pin such as the MCU ADC input. The current sensing resistor, R_s , is also recommended to be less than $0.5V/I_{M(max)}$, where $I_{M(max)}$ stands for the maximum motor current (motor stall current typical).

Power Dissipation

The main power dissipation in each device is determined by the on-resistance of internal power MOSFETs. The average power dissipation can be estimated using the following equation:

$$P_{AVG} = R_{ON} \times (I_{OUT(RMS)})^2$$

Where P_{AVG} is the average power dissipation of the device, R_{ON} is the total on-resistance of HS and LS MOSFETs and $I_{OUT(RMS)}$ is the RMS or DC output current through the load. Note that the R_{ON} value will vary with the die temperature. The higher the die temperature is, the higher will be the R_{ON} value. When the ambient temperature increases or as the device heats up, the power dissipation of the device will also increase.

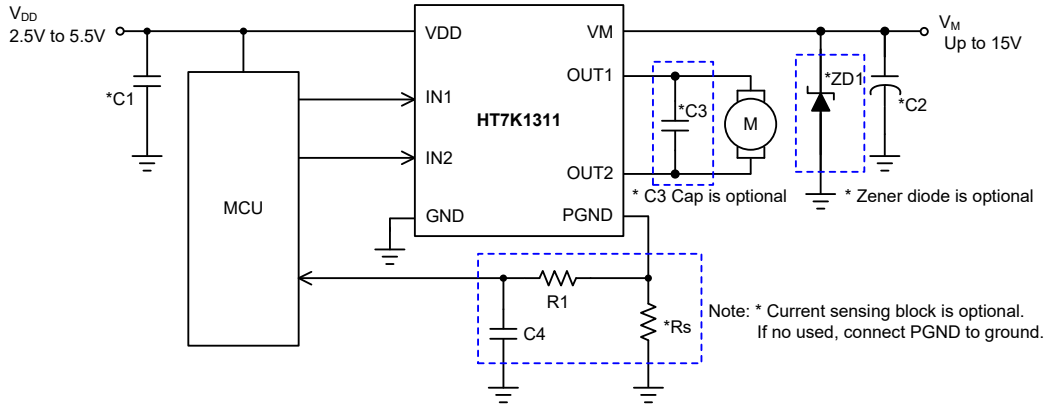

HT7K1311 Motor Current Sensing

Component/Motor Selection Guide

Motor Consideration

The appropriate motor voltage depends upon the desired RPM and power supply source. Higher motor voltages also increase the motor current rate. Note that the motor stall current must be less than the internal limit output current, I_{OCB} , to avoid failures when the motor starts up.

Controller Supply Capacitor

It is suggested to use at least a $10\mu\text{F}$ value capacitor for C1. This provides the necessary power stability for the device excluding the H-Bridge.

Motor Supply Capacitor

It is suggested to use at least a $10\mu\text{F}$ value capacitor for C2. There are two main functions for this capacitor. Firstly, it absorbs the energy released by the motor to reduce any overshoot voltage damage. Secondly, it provides a transient power source to the motor to compensate for the battery response time or for long connecting wire effects when the motor starts up or for fast control switching between forward and reverse modes.

Motor Bypass Capacitor

The bypass capacitor, C3, provides the fast flywheel path to release the inductive energy of the motor. In most applications, the capacitance value is set to a value of $0.01\mu\text{F}$ to $0.1\mu\text{F}$. Usually this capacitor is internally contained within the motor and not required externally. In some applications, especially in low speed motors, the large internal motor resistor connected with the bypass capacitor in parallel may result in an instantaneous large current when the motor starts up. It may however trigger a faulty OCP/OSP reaction which will fail to start up the motor. There

are two ways to solve this phenomenon: decrease the bypass capacitor value or add a 47Ω to 100Ω resistor in series with the bypass capacitor.

Motor Current Sensing Resistor – HT7K1311

The power dissipation of the selected motor current sensing resistor should be considered carefully. As described in the Functional Description section, the PGND maximum voltage should be lower than 0.5V . For a selected maximum motor current $I_{M(\text{max})}$, the maximum power dissipation of current sensing resistor can be calculated by $0.5\text{V} \times I_{M(\text{max})}$. For instance, if the $I_{M(\text{max})} = 1\text{A}$, the rated power of the selected current sensing resistor should be greater than 0.5W .

Motor Voltage Zener Diode

The Zener Diode, ZD1, is located at the input of the VM pin to prevent the motor's back EMF voltage from flowing into the VM pin. This back EMF voltage may exceed the IC's rated voltage and cause damage. The ZD1 is set to a value of 19V .

Layout Consideration Guide

To reduce the problems with conducted noise, there are some important points to note on the PCB layout.

1. The input capacitor C1 must be placed close to the VDD pin.
2. The motor supply capacitor C2 must be placed close to the VM pin.
3. The bypass capacitor C3 is optional and should be placed close to the motor side.
4. Ensure that the power routing path such as VM, OUT1, OUT2 and PGND is as wide as possible.
5. Extra via holes nearby the device will assist with heat sinking.

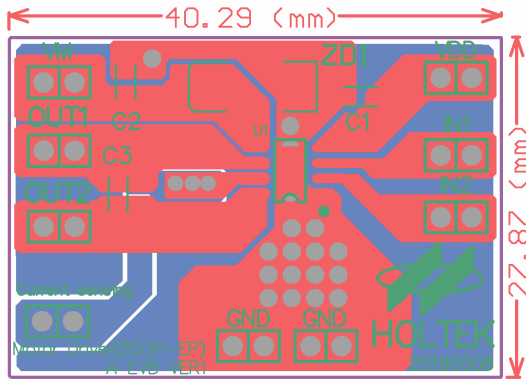

HT7K1311 PCB Layout Diagram

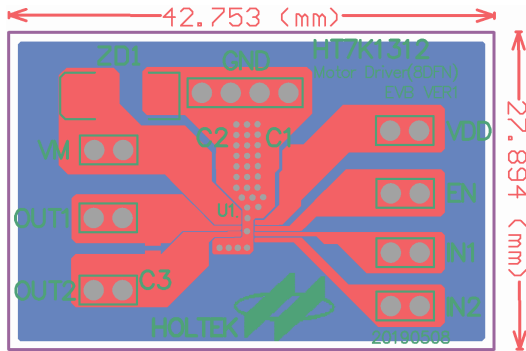

HT7K1312 PCB Layout Diagram

Thermal Consideration

The maximum power dissipation depends upon the thermal resistance of the IC package, PCB layout, rate of surrounding airflow and difference between the junction and ambient temperature. The maximum power dissipation can be calculated by the following formula:

$$P_{D(MAX)} = (T_{J(MAX)} - T_a) / \theta_{JA} \quad (W)$$

where $T_{J(MAX)}$ is the maximum junction temperature, T_a is the ambient temperature and θ_{JA} is the junction-to-ambient thermal resistance of IC package.

For maximum operating rating conditions, the maximum junction temperature is 150°C. However, it's recommended that the maximum junction temperature does not exceed 125°C during normal operation to maintain high reliability. The de-rating curve of the maximum power dissipation is show below:

$$P_{D(MAX)} = (150^\circ\text{C} - 25^\circ\text{C}) / (125^\circ\text{C}/\text{W}) = 1.0\text{W}$$

For a fixed $T_{J(MAX)}$ of 150°C, the maximum power dissipation depends upon the operating ambient temperature and the package's thermal resistance, θ_{JA} . The de-rating curve below shows the effect of rising ambient temperature on the maximum recommended power dissipation.

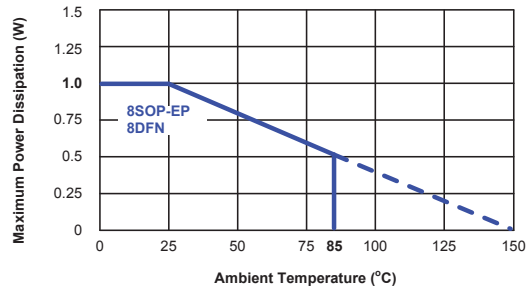

Application Circuits

HT7K1311 – Without Motor Current Sensing Application Circuit

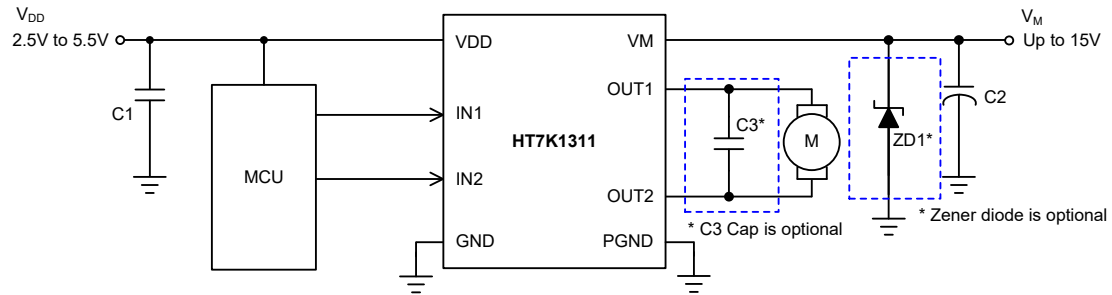

HT7K1311 – With Motor Current Sensing Application Circuit

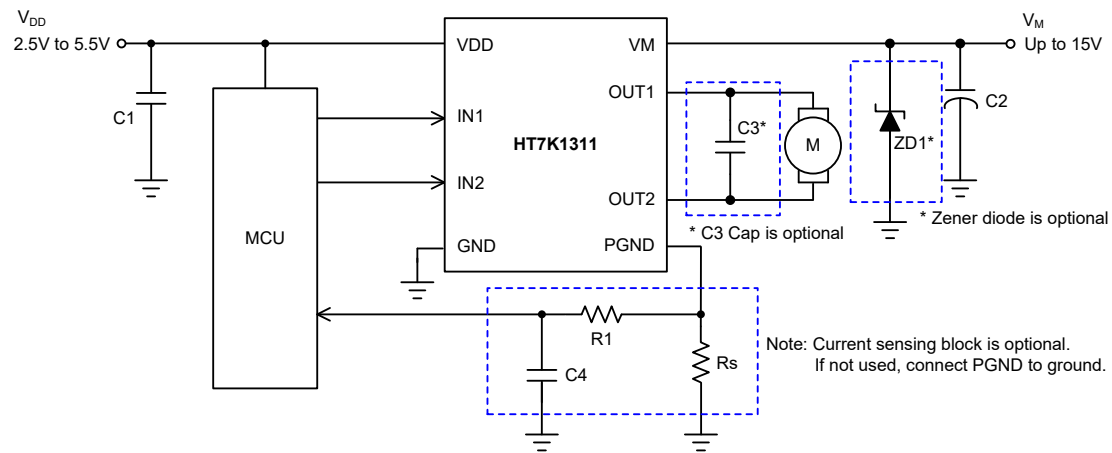

HT7K1312 – Typical Application Circuit

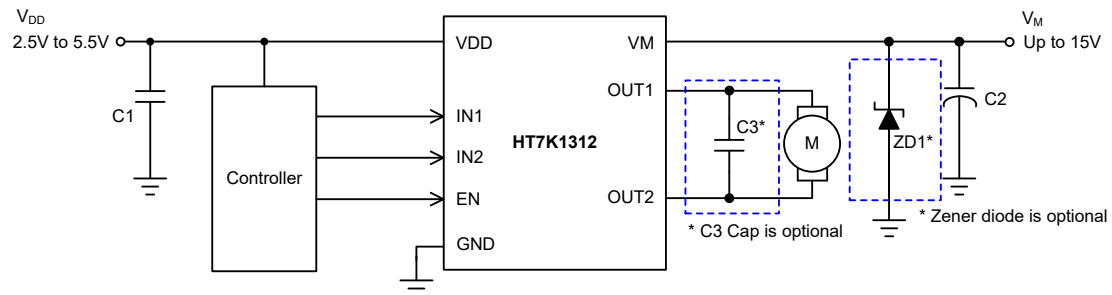

* The capacitance value of C1=10 μ F is recommended. The capacitance of C2 is determined by application – a typical value of C2=10 μ F.

* C3 is optional – a typical value ranges from 0.01 μ F to 0.1 μ F.

* ZD1 is optional – a typical value of 19V (Rohm KDZ18B).

* R_S is the motor current sensing resistor. Typically, the maximum sensing voltage is recommended to be less than 0.5V.

* The motor stall current should be less than the over current protection threshold, I_{OC}.

Package Information

Note that the package information provided here is for consultation purposes only. As this information may be updated at regular intervals users are reminded to consult the [Holtek website](#) for the latest version of the [package information](#).

Additional supplementary information with regard to packaging is listed below. Click on the relevant section to be transferred to the relevant website page.

- Further Package Information (include Outline Dimensions, Product Tape and Reel Specifications)
- Packing Materials Information
- Carton information

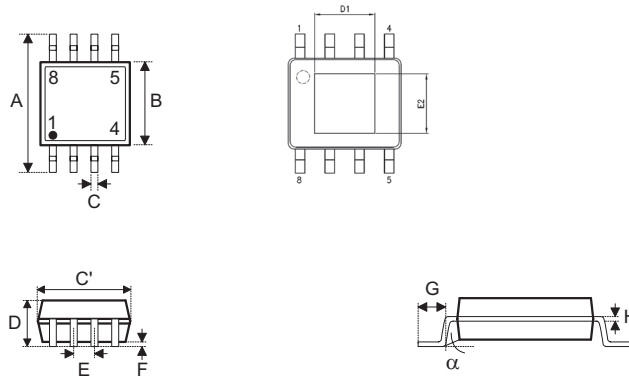
8-pin SOP-EP (150mil) Outline Dimensions

Symbol	Dimensions in inch		
	Min.	Nom.	Max.
A	—	0.236 BSC	—
B	—	0.154 BSC	—
C	0.012	—	0.020
C'	—	0.193 BSC	—
D	—	—	0.069
D1	0.059	—	—
E	—	0.050 BSC	—
E2	0.039	—	—
F	0.000	—	0.006
G	0.016	—	0.050
H	0.004	—	0.010
α	0°	—	8°

Symbol	Dimensions in mm		
	Min.	Nom.	Max.
A	—	6.00 BSC	—
B	—	3.90 BSC	—
C	0.31	—	0.51
C'	—	4.90 BSC	—
D	—	—	1.75
D1	1.50	—	—
E	—	1.27 BSC	—
E2	1.00	—	—
F	0.00	—	0.15
G	0.40	—	1.27
H	0.10	—	0.25
α	0°	—	8°

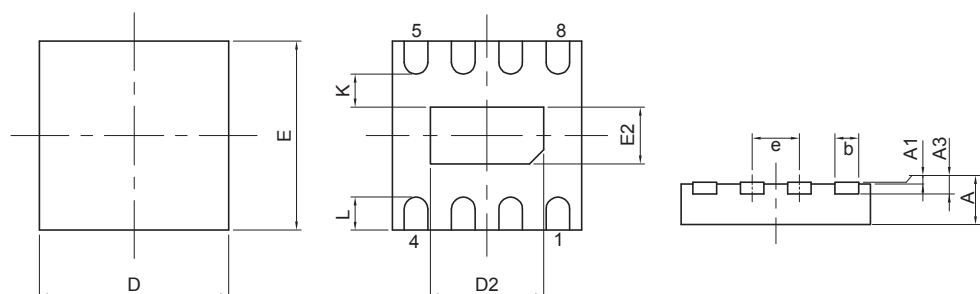
8-pin DFN (2mm×2mm×0.85mm) Outline Dimensions

Symbol	Dimensions in inch		
	Min.	Nom.	Max.
A	0.031	0.033	0.035
A1	0.000	0.001	0.002
A3	—	0.080 BSC	—
b	0.006	0.008	0.010
D	—	0.079 BSC	—
E	—	0.079 BSC	—
e	—	0.020 BSC	—
D2	0.031	0.035	0.039
E2	0.031	0.035	0.039
L	0.012	0.014	0.016
K	—	—	—

Symbol	Dimensions in mm		
	Min.	Nom.	Max.
A	0.800	0.850	0.900
A1	0.000	0.035	0.050
A3	—	0.203 BSC	—
b	0.150	0.200	0.250
D	—	2.000 BSC	—
E	—	2.000 BSC	—
e	—	0.500 BSC	—
D2	0.800	0.900	1.000
E2	0.800	0.900	1.000
L	0.300	0.350	0.400
K	—	—	—

Copyright© 2020 by HOLTEK SEMICONDUCTOR INC.

The information appearing in this Data Sheet is believed to be accurate at the time of publication. However, Holtek assumes no responsibility arising from the use of the specifications described. The applications mentioned herein are used solely for the purpose of illustration and Holtek makes no warranty or representation that such applications will be suitable without further modification, nor recommends the use of its products for application that may present a risk to human life due to malfunction or otherwise. Holtek's products are not authorized for use as critical components in life support devices or systems. Holtek reserves the right to alter its products without prior notification. For the most up-to-date information, please visit our web site at <http://www.holtek.com>.