



Ultra-Low Power Flash MCU with EPD & EEPROM

HT67F2567/HT67F2567G

Revision: V1.20 Date: November 19, 2019

www.holtek.com

Table of Contents

Features	7
CPU Features	7
Peripheral Features.....	7
General Description	8
Block Diagram	8
Pin Assignment	9
Pad Assignment – Gold Bump	10
Pad Dimensions	10
Alignment Mark Dimensions	11
Pad Coordinates – Gold Bump	11
Pin Description	13
Absolute Maximum Ratings	15
D.C. Characteristics	15
Operating Voltage Characteristics.....	15
Standby Current Characteristics	16
Operating Current Characteristics.....	16
A.C. Characteristics	17
High Speed Internal Oscillator – HIRC – Frequency Accuracy	17
Low Speed Internal Oscillator Characteristics – LIRC	17
Low Speed Crystal Oscillator Characteristics – LXT.....	18
Operating Frequency Characteristic Curves	18
System Start Up Time Characteristics	18
Input/Output Characteristics	19
Input/Output (without Multi-power) D.C. Characteristics	19
Input/Output (with Multi-power) D.C. Characteristics	19
Memory Characteristics	20
LVD/LVR Electrical Characteristics	20
EPD Driver Electrical Characteristics	21
A/D Converter Electrical Characteristics	23
Power-on Reset Characteristics	23
System Architecture	24
Clocking and Pipelining.....	24
Program Counter.....	25
Stack	25
Arithmetic and Logic Unit – ALU	26
Flash Program Memory	27
Structure.....	27
Special Vectors	27
Look-up Table	27

Table Program Example	28
In Circuit Programming – ICP	29
On-Chip Debug Support – OCDS	30
In Application Programming – IAP	30
Data Memory	46
Structure.....	46
Data Memory Addressing.....	47
General Purpose Data Memory	47
Special Purpose Data Memory	47
Special Function Register Description.....	49
Indirect Addressing Registers – IAR0, IAR1, IAR2	49
Memory Pointers – MP0, MP1L, MP1H, MP2L, MP2H.....	49
Program Memory Bank Pointer – PBP.....	50
Accumulator – ACC	51
Program Counter Low Register – PCL	51
Look-up Table Registers – TBLP, TBHP, TBLH	51
Status Register – STATUS	51
EEPROM Data Memory.....	53
EEPROM Data Memory Structure	53
EEPROM Registers	53
Reading Data from the EEPROM	55
Writing Data to the EEPROM.....	55
Write Protection.....	55
EEPROM Interrupt	55
Programming Considerations.....	56
Oscillators	57
Oscillator Overview	57
System Clock Configurations	57
Internal RC Oscillator – HIRC	58
External 32.768 kHz Crystal Oscillator – LXT	58
Internal 32kHz Oscillator – LIRC.....	58
Operating Modes and System Clocks	59
System Clocks	59
System Operation Modes.....	60
Control Registers	61
Operating Mode Switching.....	63
Standby Current Considerations	66
Wake-up	67
Watchdog Timer.....	68
Watchdog Timer Clock Source.....	68
Watchdog Timer Control Register	68
Watchdog Timer Operation	69

Reset and Initialisation	70
Reset Functions	70
Reset Initial Conditions	74
Input/Output Ports	78
Pull-high Resistors	78
Port A Wake-up	79
I/O Port Control Registers	79
I/O Port Power Source Control.....	80
Pin-shared Functions	80
I/O Pin Structures.....	83
Programming Considerations	83
Timer Modules – TM	84
Introduction	84
TM Operation	84
TM Clock Source.....	84
TM Interrupts.....	85
TM External Pins.....	85
Programming Considerations.....	86
Compact Type TM – CTM	87
Compact TM Operation.....	87
Compact Type TM Register Description.....	87
Compact Type TM Operating Modes	91
Standard Type TM – STM	97
Standard TM Operation.....	97
Standard Type TM Register Description	97
Standard Type TM Operation Modes	101
Analog to Digital Converter	110
A/D Converter Overview	110
A/D Converter Register Description	111
A/D Converter Operation.....	114
A/D Converter Reference Voltage.....	115
A/D Converter Input Signals.....	115
Conversion Rate and Timing Diagram	115
Summary of A/D Conversion Steps.....	116
Programming Considerations.....	117
A/D Conversion Function	117
A/D Conversion Programming Examples.....	118
Electronic Paper Display – EPD	119
EPD Driver Voltage	120
EPD Driver Power Supply Sequence.....	120
EPD Driver Data Display.....	121
EPD Driver Registers	121
EPD Driver Voltage Source and Biasing	134
EPD Driver Output Waveforms	134

Universal Serial Interface Module – USIM	136
SPI Interface	136
I ² C Interface	144
UART Interface.....	154
Serial Peripheral Interface – SPIA	169
SPIA Interface Operation	169
SPIA Registers	170
SPIA Communication	172
SPIA Bus Enable/Disable.....	175
SPIA Operation Steps	175
Error Detection	176
Interrupts	177
Interrupt Registers.....	177
Interrupt Operation.....	182
External Interrupt.....	183
Multi-function Interrupt	184
Timer Module Interrupts	184
LVD Interrupt.....	184
EEPROM Interrupt.....	185
A/D Converter Interrupt.....	185
Universal Serial Interface Module Interrupt.....	185
SPIA Interface Interrupt.....	185
EPD Charge Pump Voltage Ready Interrupt.....	186
EPD Refresh Finished Interrupt	186
Time Base Interrupts	186
Interrupt Wake-up Function.....	188
Programming Considerations.....	188
Low Voltage Detector – LVD	189
LVD Register	189
LVD Operation.....	190
Configuration Options.....	190
Application Circuits.....	191
Instruction Set.....	192
Introduction	192
Instruction Timing	192
Moving and Transferring Data.....	192
Arithmetic Operations.....	192
Logical and Rotate Operation	193
Branches and Control Transfer	193
Bit Operations	193
Table Read Operations	193
Other Operations.....	193

Instruction Set Summary	194
Table Conventions.....	194
Extended Instruction Set.....	196
Instruction Definition.....	198
Extended Instruction Definition	207
Package Information	214
100-pin LQFP (14mm×14mm) Outline Dimensions	215

Features

CPU Features

- Operating voltage
 - ♦ $f_{SYS}=4\text{MHz}$: 1.8V~5.5V
 - ♦ $f_{SYS}=8\text{MHz}$: 2.2V~5.5V
 - ♦ $f_{SYS}=12\text{MHz}$: 2.7V~5.5V
- Up to 0.33 μs instruction cycle with 12MHz system clock at $V_{DD}=5\text{V}$
- Power down and wake-up functions to reduce power consumption
- Oscillator types
 - ♦ Internal High Speed 4/8/12MHz RC Oscillator – HIRC
 - ♦ External Low Speed 32.768kHz Crystal – LXT
 - ♦ Internal Low Speed 32kHz RC Oscillator– LIRC, for power on reset and LVD/LVR functions only
- Fully integrated internal oscillators require no external components
- Multi-mode operation: FAST, SLOW, IDLE and SLEEP
- All instructions executed in 1~3 instruction cycles
- Table read instructions
- 115 powerful instructions
- 16-level subroutine nesting
- Bit manipulation instruction

Peripheral Features

- Flash Program Memory: 16K \times 16
- RAM Data Memory: 2304 \times 8
- True EEPROM Memory: 128 \times 8
- Watchdog Timer function
- 19 bidirectional I/O lines
- Four external interrupt lines shared with I/O pins
- Multiple Timer Modules for time measurement, input capture, compare match output, PWM output function or single pulse output function
- Universal Serial Interface Module – USIM for SPI, I²C or UART communication
- Single serial SPI interface – SPIA
- Dual Time-Base functions for generation of fixed time interrupt signals
- 7 channels 12-bits resolution A/D Converter
- Electronic Paper Display (EPD) driver
 - ♦ SEG \times 64, COM \times 1, BG \times 1
 - ♦ 2 COMBG pins can be set as Common or Background pin by application
 - ♦ Output dynamic range: 0, V_{DL} , V_{DH}
 - ♦ $V_{DL}=2.5\text{V}\sim 6\text{V}$, $V_{DH}=5\text{V}\sim 12\text{V}$
 - ♦ Driving Black/Red/White color paper
- Low voltage reset function – LVR
- Low voltage detect function – LVD
- Package type:
 - ♦ HT67F2567: 100-pin LQFP
 - ♦ HT67F2567G: Gold Bump

General Description

The HT67F2567 is a Flash Memory 8-bit high performance RISC architecture microcontrollers, designed for applications that EPD display products. Offering users the convenience of Flash Memory multi-programming features, the device also includes a wide range of functions and features. Other memory includes an area of RAM Data Memory as well as an area of true EEPROM memory for storage of non-volatile data such as serial numbers, calibration data etc.

Analog features include a multi-channel 12-bit A/D Converter. Multiple and extremely flexible Timer Modules provide timing, pulse generation and PWM generation functions. Communication with the outside world is catered for by including fully integrated SPI, I²C and UART interface functions, these popular interfaces which provide designers with a means of easy communication with external peripheral hardware. Protective features such as an internal Watchdog Timer, Low Voltage Reset and Low Voltage Detector coupled with excellent noise immunity and ESD protection ensure that reliable operation is maintained in hostile electrical environments.

A full choice of external low and internal high oscillator functions are provided including fully integrated system oscillators which require no external components for their implementation. The ability to operate and switch dynamically between a range of operating modes using different clock sources gives users the ability to optimise microcontroller operation and minimise power consumption.

The inclusion of flexible I/O programming features, Time-Base functions along with many other features ensure that the device will find excellent use in applications such as display card and electronic shelf labels (ESL) in addition to many others.

Block Diagram

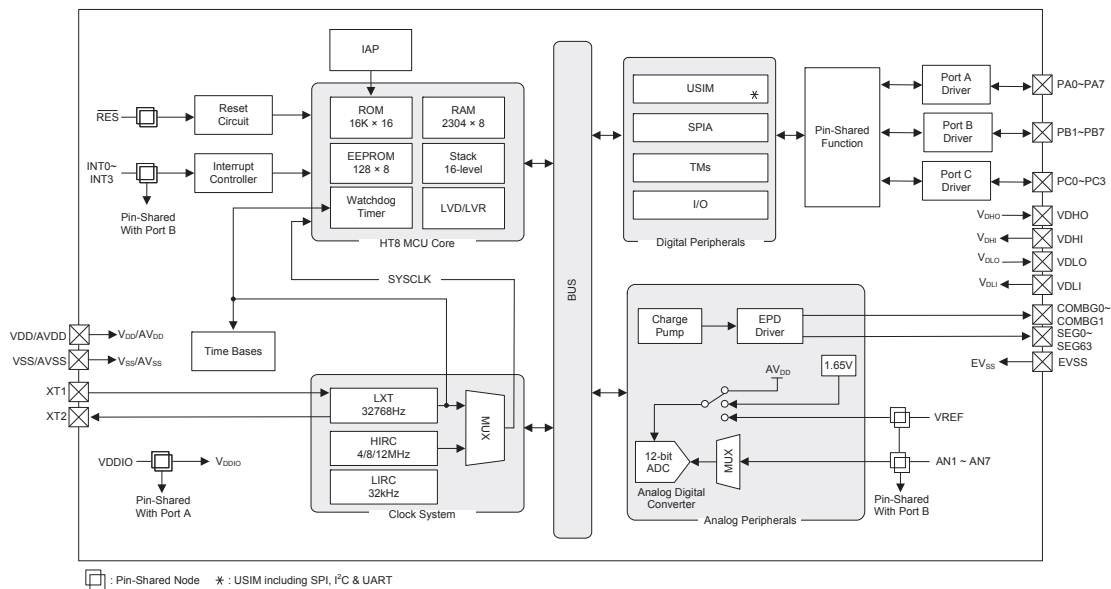

Pin Assignment

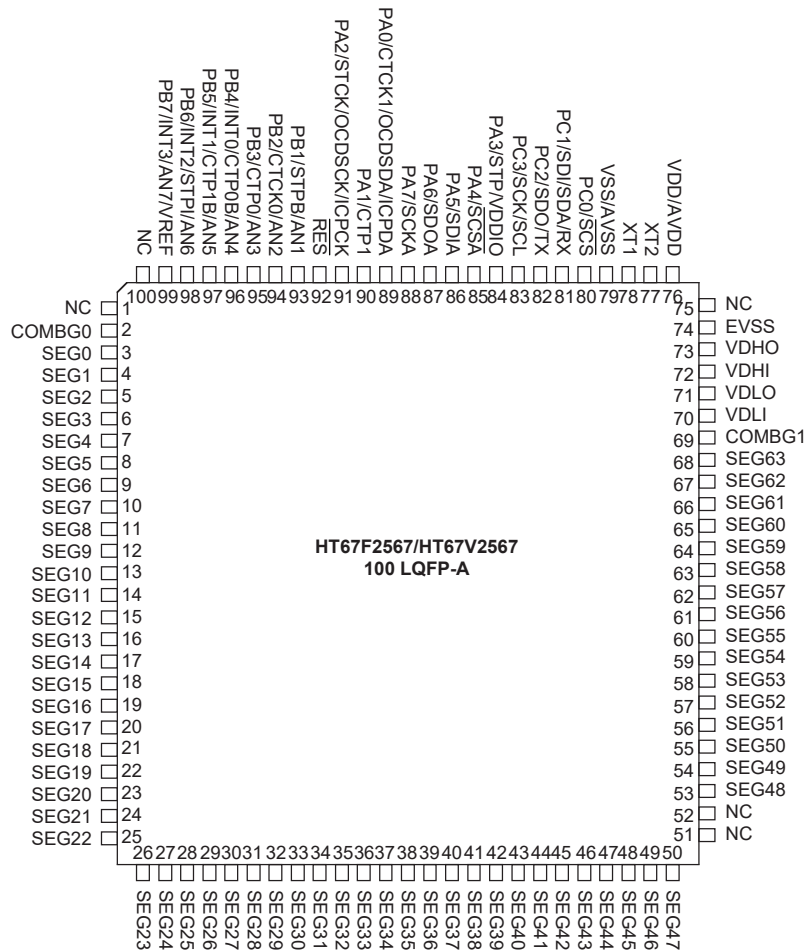

- Note: 1. If the pin-shared pin functions have multiple outputs, the desired pin-shared function is determined by the corresponding software control bits.
2. The OCSDA and OCDSCK pins are supplied as OCDS dedicated pins and as such only available for the HT67V2567 device which is the OCDS EV chip for the HT67F2567 device.

Pad Assignment – Gold Bump

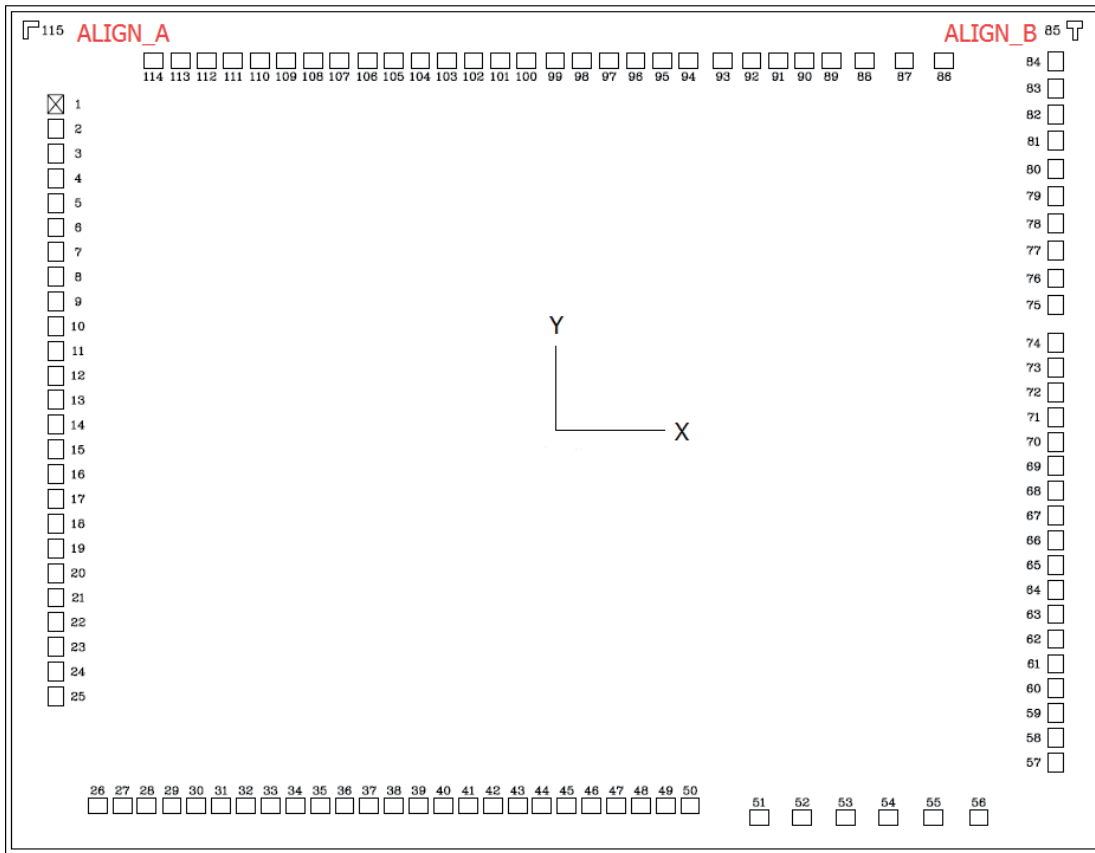

Pad Dimensions

Item	Number.	Size		Unit
		X	Y	
Chip size	—	3541	2731	μm
Chip thickness	—	152.4		μm
Pad pitch	1~84, 86~114	80		μm
Bump size	1~25, 57~84	35	49	μm
	26~56, 86~114	49	35	μm
Bump height	All pad	15±2		μm

Alignment Mark Dimensions

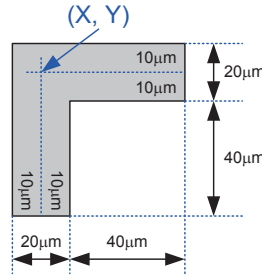
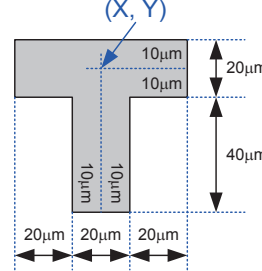
Item	Number	Size	Unit
ALIGN_A	115		µm
ALIGN_B	85		µm

Pad Coordinates – Gold Bump

Unit: µm

Pad No.	Pad Name	X	Y	Pad No.	Pad Name	X	Y
1	COMBG0	-1621.000	1058.010	59	SEG50	1621.000	-916.410
2	COMBG0	-1621.000	978.010	60	SEG51	1621.000	-836.410
3	SEG0	-1621.000	898.010	61	SEG52	1621.000	-756.410
4	SEG1	-1621.000	818.010	62	SEG53	1621.000	-676.410
5	SEG2	-1621.000	738.010	63	SEG54	1621.000	-596.410
6	SEG3	-1621.000	658.010	64	SEG55	1621.000	-516.410
7	SEG4	-1621.000	578.010	65	SEG56	1621.000	-436.410
8	SEG5	-1621.000	498.010	66	SEG57	1621.000	-356.410
9	SEG6	-1621.000	418.010	67	SEG58	1621.000	-276.410
10	SEG7	-1621.000	338.010	68	SEG59	1621.000	-196.410
11	SEG8	-1621.000	258.010	69	SEG60	1621.000	-116.410
12	SEG9	-1621.000	178.010	70	SEG61	1621.000	-36.410
13	SEG10	-1621.000	98.010	71	SEG62	1621.000	43.590
14	SEG11	-1621.000	18.010	72	SEG63	1621.000	123.590
15	SEG12	-1621.000	-61.990	73	COMBG1	1621.000	203.590
16	SEG13	-1621.000	-141.990	74	COMBG1	1621.000	283.590
17	SEG14	-1621.000	-221.990	75	VDLI	1621.000	406.820
18	SEG15	-1621.000	-301.990	76	VDLI	1621.000	492.820
19	SEG16	-1621.000	-381.990	77	VDLO	1621.000	583.846
20	SEG17	-1621.000	-461.990	78	VDLO	1621.000	669.846
21	SEG18	-1621.000	-541.990	79	VDHI	1621.000	760.660
22	SEG19	-1621.000	-621.990	80	VDHI	1621.000	846.660
23	SEG20	-1621.000	-701.990	81	VDHO	1621.000	937.540
24	SEG21	-1621.000	-781.990	82	VDHO	1621.000	1023.540

Pad No.	Pad Name	X	Y	Pad No.	Pad Name	X	Y
25	SEG22	-1621.000	-861.990	83	EVSS	1621.000	1109.478
26	SEG23	-1484.880	-1216.000	84	EVSS	1621.000	1195.478
27	SEG24	-1404.880	-1216.000	85	ALIGN_B	1682.500	1297.500
28	SEG25	-1324.880	-1216.000	86	VDD	1258.158	1198.000
29	SEG26	-1244.880	-1216.000	87	VDD	1128.858	1198.000
30	SEG27	-1164.880	-1216.000	88	VDD	999.558	1198.000
31	SEG28	-1084.880	-1216.000	89	XT2	891.868	1198.000
32	SEG29	-1004.880	-1216.000	90	XT1	805.868	1198.000
33	SEG30	-924.880	-1216.000	91	VSS	719.868	1198.000
34	SEG31	-844.880	-1216.000	92	VSS	633.868	1198.000
35	SEG32	-764.880	-1216.000	93	VSS	541.198	1198.000
36	SEG33	-684.880	-1216.000	94	PC0	430.178	1198.000
37	SEG34	-604.880	-1216.000	95	PC1	344.178	1198.000
38	SEG35	-524.880	-1216.000	96	PC2	258.178	1198.000
39	SEG36	-444.880	-1216.000	97	PC3	172.178	1198.000
40	SEG37	-364.880	-1216.000	98	PA3	83.218	1198.000
41	SEG38	-284.880	-1216.000	99	VSS:CLAMP	-2.782	1198.000
42	SEG39	-204.880	-1216.000	100	PA4	-95.322	1198.000
43	SEG40	-124.880	-1216.000	101	PA5	-181.322	1198.000
44	SEG41	-44.880	-1216.000	102	PA6	-267.322	1198.000
45	SEG42	35.120	-1216.000	103	PA7	-353.322	1198.000
46	SEG43	115.120	-1216.000	104	PA0	-439.322	1198.000
47	SEG44	195.120	-1216.000	105	PA1	-525.322	1198.000
48	SEG45	275.120	-1216.000	106	PA2	-611.322	1198.000
49	SEG46	355.120	-1216.000	107	RES	-701.442	1198.000
50	SEG47	435.120	-1216.000	108	PB1	-787.442	1198.000
51	DUMMY_BUMP	657.960	-1254.160	109	PB2	-873.442	1198.000
52	DUMMY_BUMP	797.960	-1254.160	110	PB3	-959.442	1198.000
53	DUMMY_BUMP	937.960	-1254.160	111	PB4	-1045.442	1198.000
54	DUMMY_BUMP	1077.960	-1254.160	112	PB5	-1131.442	1198.000
55	DUMMY_BUMP	1223.960	-1254.160	113	PB6	-1217.442	1198.000
56	DUMMY_BUMP	1369.960	-1254.160	114	PB7	-1303.442	1198.000
57	SEG48	1621.000	-1076.410	115	ALIGN_A	-1702.500	1297.500
58	SEG49	1621.000	-996.410				

Pin Description

With the exception of the power pins and some relevant transformer control pins, all pins on the device can be referenced by their Port names, e.g. PA0, PA1 etc, which refer to the digital I/O function of the pins. However these Port pins are also shared with other function such as the Timer Module pins etc. The function of each pin is listed in the following table, however the details behind how each pin is configured is contained in other sections of the datasheet. Note that where more than one package type exists the table will reflect the situation for the larger package type.

Pin Name	Function	OPT	I/T	O/T	Description
PA0/CTCK1/OCSDA/ ICPDA	PA0	PAWU PAPU	ST	CMOS	General purpose I/O. Register enabled pull-up and wake-up
	CTCK1	—	ST	—	CTM1 clock input
	OCSDA	—	ST	CMOS	OCDS Data/Address, for EV chip only
	ICPDA	—	ST	CMOS	ICP Data/Address
PA1/CTP1	PA1	PAWU PAPU PAS0	ST	CMOS	General purpose I/O. Register enabled pull-up and wake-up
	CTP1	PAS0	—	CMOS	CTM1 output
PA2/STCK/OCDSCK/ ICPCK	PA2	PAWU PAPU	ST	CMOS	General purpose I/O. Register enabled pull-up and wake-up
	STCK	—	ST	—	STM clock input pin
	OCDSCK	—	ST	—	OCDS Clock pin, for EV chip only
	ICPCK	—	ST	—	ICP Clock pin
PA3/STP/VDDIO	PA3	PAWU PAPU PAS0	ST	CMOS	General purpose I/O. Register enabled pull-up and wake-up
	STP	PAS0	—	CMOS	STM output
	VDDIO	PAS0 PMPS	PWR	—	Power supply for SPI/I ² C/UART input/output pins
PA4/ \overline{SCSA}	PA4	PAWU PAPU PAS1	ST	CMOS	General purpose I/O. Register enabled pull-up and wake-up
	\overline{SCSA}	PAS1	ST	CMOS	SPIA slave select pin
PA5/SDIA	PA5	PAWU PAPU PAS1	ST	CMOS	General purpose I/O. Register enabled pull-up and wake-up
	SDIA	PAS1	ST	—	SPIA serial data input
PA6/SDOA	PA6	PAWU PAPU PAS1	ST	CMOS	General purpose I/O. Register enabled pull-up and wake-up
	SDOA	PAS1	—	CMOS	SPIA serial data output
PA7/SCKA	PA7	PAWU PAPU PAS1	ST	CMOS	General purpose I/O. Register enabled pull-up and wake-up
	SCKA	PAS1	ST	CMOS	SPIA serial clock
PB1/STPB/AN1	PB1	PBPU PBS0	ST	CMOS	General purpose I/O. Register enabled pull-high
	STPB	PBS0	—	CMOS	STM inverting output
	AN1	PBS0	AN	—	A/D Converter external input 1
PB2/CTCK0/AN2	PB2	PBPU PBS0	ST	CMOS	General purpose I/O. Register enabled pull-high
	CTCK0	PBS0	ST	—	CTM0 clock input
	AN2	PBS0	AN	—	A/D Converter external input 2

Pin Name	Function	OPT	I/T	O/T	Description
PB3/CTP0/AN3	PB3	PBPU PBS0	ST	CMOS	General purpose I/O. Register enabled pull-high
	CTP0	PBS0	—	CMOS	CTM0 output
	AN3	PBS0	AN	—	A/D Converter external input 3
PB4/INT0/CTP0B/AN4	PB4	PBPU PBS1	ST	CMOS	General purpose I/O. Register enabled pull-high
	INT0	PBS1 INTEG INTC0	ST	—	External interrupt input 0
	CTP0B	PBS1	—	CMOS	CTM0 inverting output
PB5/INT1/CTP1B/AN5	PB5	PBPU PBS1	ST	CMOS	General purpose I/O. Register enabled pull-high
	INT1	PBS1	ST	—	External interrupt input 1
	CTP1B	PBS1	—	CMOS	CTM1 inverting output
PB6/INT2/STPI/AN6	PB6	PBPU PBS1	ST	CMOS	General purpose I/O. Register enabled pull-high
	INT2	PBS1 INTEG INTC2	ST	—	External interrupt input 2
	STPI	PBS1	ST	—	STM capture input
PB7/INT3/AN7/VREF	PB7	PBPU PBS1	ST	CMOS	General purpose I/O. Register enabled pull-high
	INT3	PBS1 INTEG INTC2	ST	—	External interrupt input 3
	AN7	PBS1	AN	—	A/D Converter external input 7
PC0/ \overline{SCS}	VREF	PBS1	AN	—	A/D Converter external reference voltage input
	PC0	PCPU PCS0	ST	CMOS	General purpose I/O. Register enabled pull-high
PC1/SDI/SDA/RX	\overline{SCS}	PCS0	ST	CMOS	SPI slave select pin
	PC1	PCPU PCS0	ST	CMOS	General purpose I/O. Register enabled pull-high
PC2/SDO/TX	SDI	PCS0	ST	—	SPI serial data input
	SDA	PCS0	ST	NMOS	I ² C data line
	RX	PCS0	ST	—	UART RX serial data input
PC3/SCK/SCL	PC2	PCPU PCS0	ST	CMOS	General purpose I/O. Register enabled pull-high
	SDO	PCS0	—	CMOS	SPI serial data output
	TX	PCS0	—	CMOS	UART TX serial data output
RES	PC3	PCPU PCS0	ST	CMOS	General purpose I/O. Register enabled pull-high
	SCK	PCS0	ST	CMOS	SPI serial clock
	SCL	PCS0	ST	NMOS	I ² C clock line
XT2	RES	—	ST	—	External reset input
XT1	XT2	—	—	LXT	LXT oscillator pin
	XT1	—	LXT	—	LXT oscillator pin

Pin Name	Function	OPT	I/T	O/T	Description
EPD					
SEG0~SEG63	SEG0~63	—	—	AN	EPD Segment output
COMBG0~COMBG1	COMBG0~1	—	—	AN	EPD Common/Background output
VDHO	VDHO	—	—	AN	EPD charge pump V_{DH} output
VDHI	VDHI	—	AN	—	EPD charge pump V_{DH} input
VDLO	VDLO	—	—	AN	EPD charge pump V_{DL} output
VDLI	VDLI	—	AN	—	EPD charge pump V_{DL} input
EVSS	EVSS	—	PWR	—	EPD negative power supply.
Power					
VDD/AVDD	VDD	—	PWR	—	Digital positive power supply
	AVDD	—	PWR	—	Analog positive power supply
VSS/AVSS	VSS	—	PWR	—	Digital negative power supply
	AVSS	—	PWR	—	Analog negative power supply

Legend: I/T: Input type; O/T: Output type;
 OPT: Optional by register option; ST: Schmitt Trigger input;
 CMOS: CMOS output; NMOS: NMOS output;
 AN: Analog signal; PWR: Power;
 LXT: Low frequency crystal oscillator.

Absolute Maximum Ratings

Supply Voltage	$V_{SS}-0.3V$ to $6.0V$
Input Voltage	$V_{SS}-0.3V$ to $V_{DD}+0.3V$
Storage Temperature.....	$-50^{\circ}C$ to $125^{\circ}C$
Operating Temperature.....	$-40^{\circ}C$ to $85^{\circ}C$
I_{OL} Total	80mA
I_{OH} Total	-80mA
Total Power Dissipation	500mW

Note: These are stress ratings only. Stresses exceeding the range specified under “Absolute Maximum Ratings” may cause substantial damage to the device. Functional operation of this device at other conditions beyond those listed in the specification is not implied and prolonged exposure to extreme conditions may affect device reliability.

D.C. Characteristics

For data in the following tables, note that factors such as oscillator type, operating voltage, operating frequency, pin load conditions, temperature and program instruction type, etc., can all exert an influence on the measured values.

Operating Voltage Characteristics

$T_a=25^{\circ}C$

Symbol	Parameter	Test Conditions	Min.	Typ.	Max.	Unit
V_{DD}	Operating Voltage – HIRC	$f_{SYS}=4MHz$	1.8	—	5.5	V
		$f_{SYS}=8MHz$	2.2	—	5.5	
		$f_{SYS}=12MHz$	2.7	—	5.5	
	Operating Voltage – LXT	$f_{SYS}=32768Hz$	1.8	—	5.5	V

Standby Current Characteristics

Ta=25°C, unless otherwise specified

Symbol	Standby Mode	Test Conditions		Min.	Typ.	Max.	Max. @ 85°C	Unit
		V _{DD}	Conditions					
I _{STB}	SLEEP Mode	1.8V	WDT off, Time Base off (LXT on)	—	0.10	0.15	0.70	μA
		3V		—	0.12	0.15	1.00	
		5V		—	0.2	0.5	1.2	
		1.8V	WDT off, Time Base on (LXT on)	—	0.12	0.22	0.70	
		3V		—	0.15	0.22	1.00	
		5V		—	0.23	0.60	1.20	
		1.8V	WDT on, Time Base on (LXT on)	—	0.15	0.22	1.00	
		3V		—	0.18	0.22	1.50	
		5V		—	0.30	0.75	1.80	
	IDLE0 Mode – LXT	1.8V	f _{SUB} on	—	2.4	4.0	4.8	μA
		3V		—	3	5	6	
		5V		—	5	10	12	
	IDLE1 Mode – HIRC	1.8V	f _{SUB} on, f _{SYS} =4MHz	—	0.144	0.200	0.240	mA
		3V		—	0.18	0.25	0.30	
		5V		—	0.40	0.60	0.72	
		2.2V	f _{SUB} on, f _{SYS} =8MHz	—	0.3	0.6	0.8	
		3V		—	0.5	1.0	1.8	
		5V		—	1.0	2.0	2.2	
2.7V		f _{SUB} on, f _{SYS} =12MHz	—	0.4	0.8	1.0		
3V			—	0.6	1.2	1.4		
5V	—		1.2	2.4	2.6			

Note: When using the characteristic table data, the following notes should be taken into consideration:

1. Any digital inputs are setup in a non-floating condition.
2. All measurements are taken under conditions of no load and with all peripherals in an off state.
3. There are no DC current paths.
4. All Standby Current values are taken after a HALT instruction execution thus stopping all instruction execution.

Operating Current Characteristics

Ta=25°C

Symbol	Operating Mode	Test Conditions		Min.	Typ.	Max.	Unit
		V _{DD}	Conditions				
I _{DD}	SLOW Mode – LXT	1.8V	f _{SYS} =32768Hz	—	8	16	μA
		3V		—	10	20	
		5V		—	30	50	
	FAST Mode – HIRC	1.8V	f _{SYS} =4MHz	—	0.3	0.5	mA
		3V		—	0.4	0.6	
		5V		—	0.8	1.2	
		2.2V	f _{SYS} =8MHz	—	0.8	1.2	
		3V		—	1.0	1.5	
		5V		—	2.0	3.0	
		2.7V	f _{SYS} =12MHz	—	1.2	2.2	
		3V		—	1.5	2.7	
	5V	—		3.0	4.5		

Note: When using the characteristic table data, the following notes should be taken into consideration:

1. Any digital inputs are setup in a non-floating condition.
2. All measurements are taken under conditions of no load and with all peripherals in an off state.
3. There are no DC current paths.
4. All Operating Current values are measured using a continuous NOP instruction program loop.

A.C. Characteristics

For data in the following tables, note that factors such as oscillator type, operating voltage, operating frequency and temperature etc., can all exert an influence on the measured values.

High Speed Internal Oscillator – HIRC – Frequency Accuracy

During the program writing operation the writer will trim the HIRC oscillator at a user selected HIRC frequency and user selected voltage of either 3V or 5V.

Symbol	Parameter	Test Conditions		Min	Typ	Max	Unit		
		V _{DD}	Temp.						
f _{HIRC}	4 MHz Writer Trimmed HIRC Frequency	3V/5V	25°C	-1%	4	+1%	MHz		
			-40°C~85°C	-2%	4	+2%			
		2.2V~5.5V	25°C	-2.5%	4	+2.5%			
			-40°C~85°C	-3%	4	+3%			
		1.8V~5.5V	25°C	-4%	4	+4%			
			-40°C~85°C	-5%	4	+5%			
	8 MHz Writer Trimmed HIRC Frequency	3V/5V	25°C	-1%	8	+1%	MHz		
			-40°C~85°C	-2%	8	+2%			
		2.2V~5.5V	25°C	-2.5%	8	+2.5%			
			-40°C~85°C	-3%	8	-3%			
		12 MHz Writer Trimmed HIRC Frequency	5V	25°C	-1%	12		+1%	MHz
				-40°C~85°C	-2%	12		+2%	
2.7V~5.5V	25°C	-2.5%	12	+2.5%					
	-40°C~85°C	-3%	12	+3%					

Note: 1. The 3V/5V values for V_{DD} are provided as these are the two selectable fixed voltages at which the HIRC frequency is trimmed by the writer.

2. The row below the 3V/5V trim voltage row is provided to show the values for the full V_{DD} range operating voltage. It is recommended that the trim voltage is fixed at 3V for application voltage ranges from 2.2V to 3.6V and fixed at 5V for application voltage ranges from 3.3V to 5.5V.
3. The minimum and maximum tolerance values provided in the table are only for the frequency at which the writer trims the HIRC oscillator. After trimming at this chosen specific frequency any change in HIRC oscillator frequency using the oscillator register control bits by the application program will give a frequency tolerance to within ±20%.

Low Speed Internal Oscillator Characteristics – LIRC

Symbol	Parameter	Test Conditions		Min.	Typ.	Max.	Unit
		V _{DD}	Temp.				
f _{LIRC}	LIRC Frequency	2.2V~5.5V	25°C	-5%	32	+5%	kHz
			-40°C~85°C	-10%	32	+10%	
t _{START}	LIRC Start Up Time	—	—	—	—	100	µs

Low Speed Crystal Oscillator Characteristics – LXT

Ta=25°C

Symbol	Parameter	Test Conditions		Min.	Typ.	Max.	Unit
		V _{DD}	Conditions				
f _{LXT}	Oscillator Frequency	1.8V~5.5V	—	—	32768	—	Hz
	Duty Cycle	—	—	45	50	55	%
t _{START}	Start Up Time	3V	—	—	—	600	ms
		5V	—	—	—	600	
R _{NEG}	Negative Resistance ^(Note)	1.8V	—	3×ESR	—	—	Ω

Note: C1 and C2 are external components. C1=C2=7pF, C_L<7pF, ESR=65kΩ (Max.).

Operating Frequency Characteristic Curves

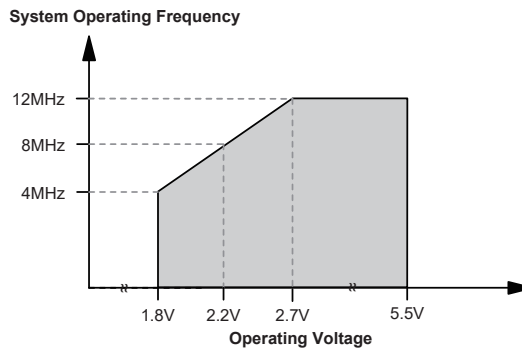

System Start Up Time Characteristics

Ta=25°C

Symbol	Parameter	Test Conditions		Min.	Typ.	Max.	Unit
		V _{DD}	Conditions				
t _{SST}	System Start-up Time Wake-up from Condition where f _{sys} is Off	—	f _{sys} =f _H ~f _H /64, f _H =f _{HIRC}	—	16	—	t _{sys}
		—	f _{sys} =f _{SUB} =f _{LXT}	—	1024	—	t _{sys}
	System Start-up Time Wake-up from Condition where f _{sys} is On	—	f _{sys} =f _H ~f _H /64, f _H =f _{HIRC}	—	2	—	t _{sys}
		—	f _{sys} =f _{SUB} =f _{LXT}	—	2	—	t _{sys}
	System Speed Switch Time FAST to SLOW Mode or SLOW to FAST Mode	—	f _{HIRC} switches from off → on	—	16	—	t _{HIRC}
—		f _{LXT} switches from off → on	—	1024	—	t _{LXT}	
t _{RSTD}	System Reset Delay Time Reset Source from Power-on Reset or LVR Hardware Reset	—	RR _{POR} =5V/ms	42	48	54	ms
	System Reset Delay Time LVRC/WDTC/RSTC Software Reset	—	—	—	—	—	—
	System Reset Delay Time Reset Source from WDT Overflow or Reset Pin Reset	—	—	14	16	18	ms
t _{SRESET}	Minimum Software Reset Width to Reset	—	—	45	90	120	μs

Note: 1. For the System Start-up time values, whether f_{sys} is on or off depends upon the mode type and the chosen f_{sys} system oscillator. Details are provided in the System Operating Modes section.

- The time units, shown by the symbols t_{HIRC}, t_{sys} etc. are the inverse of the corresponding frequency values as provided in the frequency tables. For example t_{HIRC}=1/f_{HIRC}, t_{sys}=1/f_{sys} etc.
- If the LIRC is used as the system clock and if it is off when in the SLEEP Mode, then an additional LIRC start up time, t_{START}, as provided in the LIRC frequency table, must be added to the t_{SST} time in the table above.
- The System Speed Switch Time is effectively the time taken for the newly activated oscillator to start up.

Input/Output Characteristics

Ta=25°C

Input/Output (without Multi-power) D.C. Characteristics

Symbol	Parameter	Test Conditions		Min.	Typ.	Max.	Unit
		V _{DD}	Conditions				
V _{IL}	Input Low Voltage for I/O Ports except PC0~PC3 and RES Pins	5V	—	0	—	1.5	V
		—	—	0	—	0.2V _{DD}	
	—	Input Low Voltage for $\overline{\text{RES}}$ pin	—	—	0	—	
V _{IH}	Input High Voltage for I/O Ports except PC0~PC3 and RES Pins	5V	—	3.5	—	5.0	V
		—	—	0.8V _{DD}	—	V _{DD}	
	—	Input High Voltage for $\overline{\text{RES}}$ pin	—	—	0.9V _{DD}	—	
I _{OL}	Sink Current for I/O Ports except PC0~PC3 Pins	3V	V _{OL} =0.1V _{DD}	16	32	—	mA
		5V		32	65	—	
I _{OH}	Source Current for I/O Ports except PC0~PC3 Pins	3V	V _{OH} =0.9V _{DD}	-4	-8	—	mA
		5V		-8	-16	—	
R _{PH}	Pull-high Resistance for I/O Ports except PC0~PC3 Pins ^(Note)	3V	LVPU=0 PxPU=FFH (Px: PA, PB, PC)	20	60	100	kΩ
		5V		10	30	50	
		3V	LVPU=1 PxPU=FFH (Px: PA, PB, PC)	6.67	15	23	
		5V		3.5	7.5	12	
I _{LEAK}	Input Leakage Current for I/O Ports except PC0~PC3 Pins	5V	V _{IN} =V _{DD} or V _{IN} =V _{SS}	—	—	±1	μA
t _{TCK}	TM Clock Input Minimum Pulse Width	—	—	0.3	—	—	μs
t _{TPI}	TM Capture Input Pin Minimum Pulse Width	—	—	0.3	—	—	μs
t _{RES}	External Reset Minimum Low Pulse Width	—	—	10	—	—	μs

Input/Output (with Multi-power) D.C. Characteristics

Symbol	Parameter	Test Conditions		Min.	Typ.	Max.	Unit
		V _{DD}	Conditions				
V _{DD}	V _{DD} Power Supply for PC0~PC3 Pins	—	—	1.8	5.0	5.5	V
V _{DDIO}	V _{DDIO} Power Supply for PC0~PC3 Pins	—	—	1.8	—	V _{DD}	V
V _{IL}	Input Low Voltage for PC0~PC3 Pins	5V	Pin power=V _{DD} or V _{DDIO} , V _{DDIO} =V _{DD}	0	—	1.5	V
		—	Pin power=V _{DD} or V _{DDIO}	0	—	0.2 (V _{DD} or V _{DDIO})	
V _{IH}	Input High Voltage for PC0~PC3 Pins	5V	Pin power=V _{DD} or V _{DDIO} , V _{DDIO} =V _{DD}	3.5	—	5.0	V
		—	Pin power=V _{DD} or V _{DDIO}	0.8V _{DD}	—	V _{DD} or V _{DDIO}	
I _{OL}	Sink Current for PC0~PC3 Pins	3V	V _{OL} =0.1 (V _{DD} or V _{DDIO}), V _{DDIO} =V _{DD}	16	32	—	mA
		5V	V _{OL} =0.1 (V _{DD} or V _{DDIO}), V _{DDIO} =V _{DD}	32	65	—	
			V _{OL} =0.1 (V _{DD} or V _{DDIO}), V _{DDIO} =3V	20	40	—	
I _{OH}	Source Current for PC0~PC3 Pins	3V	V _{OH} =0.9 (V _{DD} or V _{DDIO}), V _{DDIO} =V _{DD}	-4	-8	—	mA
		5V	V _{OH} =0.9 (V _{DD} or V _{DDIO}), V _{DDIO} =V _{DD}	-8	-16	—	
			V _{OH} =0.9 (V _{DD} or V _{DDIO}), V _{DDIO} =3V	-2.5	-5.0	—	

Symbol	Parameter	Test Conditions		Min.	Typ.	Max.	Unit	
		V _{DD}	Conditions					
R _{PH}	Pull-high Resistance for PC0~PC3 Pins <small>(Note)</small>	3V	V _{DDIO} =V _{DD} , LVPU=0 P _X PU=FFH (P _X =PA, PB, PC)	20	60	100	kΩ	
		5V	V _{DDIO} =V _{DD} , LVPU=0, P _X PU=FFH (P _X =PA, PB, PC)	10	30	50		
			V _{DDIO} =3V, LVPU=0, P _X PU=FFH (P _X =PA, PB, PC)	36	110	180		
		3V	V _{DDIO} =V _{DD} , LVPU=1, P _X PU=FFH (P _X =PA, PB, PC)	6.67	15	23		
			5V	V _{DDIO} =V _{DD} , LVPU=1, P _X PU=FFH (P _X =PA, PB, PC)	3.5	7.5		12
				V _{DDIO} =3V, LVPU=1, P _X PU=FFH (P _X =PA, PB, PC)	9	27.5		45
I _{LEAK}	Input Leakage Current for PC0~PC3 Pins	5V	V _{IN} =V _{DD} or V _{IN} =V _{DDIO} or V _{IN} =V _{SS}	—	—	±1	μA	

Note: The R_{PH} internal pull high resistance value is calculated by connecting to ground and enabling the input pin with a pull-high resistor and then measuring the input sink current at the specified supply voltage level. Dividing the voltage by this measured current provides the R_{PH} value.

Memory Characteristics

T_a=-40°C~85°C, unless otherwise specified

Symbol	Parameter	Test Conditions		Min.	Typ.	Max.	Unit
		V _{DD}	Conditions				
V _{RW}	V _{DD} for Read/Write	—	—	V _{DDmin}	—	V _{DDmax}	V
Flash Program / Data EEPROM Memory							
t _{DEW}	Erase/Write Cycle Time – Flash Program Memory	—	—	—	2	3	ms
	Write Cycle Time – Data EEPROM Memory	—	—	—	4	6	
I _{DDPGM}	Programming/Erase Current on V _{DD}	—	—	—	—	5.0	mA
E _P	Cell Endurance – Flash Program Memory	—	—	10K	—	—	E/W
	Cell Endurance – Data EEPROM Memory	—	—	100K	—	—	E/W
t _{RETD}	ROM Data Retention Time	—	T _a =25°C	—	40	—	Year
RAM Data Memory							
V _{DR}	RAM Data Retention Voltage	—	Device in SLEEP Mode	1.0	—	—	V

LVD/LVR Electrical Characteristics

T_a=25°C

Symbol	Parameter	Test Conditions		Min.	Typ.	Max.	Unit
		V _{DD}	Conditions				
V _{LVR}	Low Voltage Reset Voltage	—	LVR enable, voltage select 1.70V	-5%	1.70	+5%	V
			LVR enable, voltage select 1.90V		1.90		
			LVR enable, voltage select 2.55V	-3%	2.55	+3%	
			LVR enable, voltage select 3.15V		3.15		
			LVR enable, voltage select 3.80V		3.80		

Symbol	Parameter	Test Conditions		Min.	Typ.	Max.	Unit
		V _{DD}	Conditions				
V _{LVD}	Low Voltage Detection Voltage	—	LVD enable, voltage select 1.8V	-5%	1.8	+5%	V
			LVD enable, voltage select 1.9V		1.9		
			LVD enable, voltage select 2.0V		2.0		
			LVD enable, voltage select 2.1V		2.1		
			LVD enable, voltage select 2.2V		2.2		
			LVD enable, voltage select 2.3V		2.3		
			LVD enable, voltage select 2.4V		2.4		
			LVD enable, voltage select 2.5V		2.5		
			LVD enable, voltage select 2.6V		2.6		
			LVD enable, voltage select 2.7V		2.7		
			LVD enable, voltage select 2.8V		2.8		
			LVD enable, voltage select 2.9V		2.9		
			LVD enable, voltage select 3.0V		3.0		
			LVD enable, voltage select 3.3V		3.3		
LVD enable, voltage select 3.6V	3.6						
LVD enable, voltage select 4.0V	4.0						
I _{LVR/LVD}	Operating Current	3V	LVD enable, LVR enable,	—	—	10	μA
		5V	V _{LVR} =1.9V, V _{LVD} =2V	—	8	15	
t _{LVDS}	LVDO Stable Time	—	For LVR enable, LVD off → on	—	—	15	μs
		—	For LVR disable, LVD off → on	—	—	150	
t _{LVR}	Minimum Low Voltage Width to Reset	—	—	120	240	480	μs
t _{LVD}	Minimum Low Voltage Width to Interrupt	—	—	60	120	240	μs
I _{LVR}	Additional Current for LVR Enable	—	LVD disable	—	—	8	μA
I _{LVD}	Additional Current for LVD Enable	—	LVR disable	—	—	8	μA

EPD Driver Electrical Characteristics

T_a=-40°C~85°C, unless otherwise specify

Symbol	Parameter	Test Conditions		Min.	Typ.	Max.	Unit
		V _{DD}	Conditions				
V _{IN}	EPD Operating Voltage	—	Power supply from AVDD pin	1.8	—	5.5	V
		—	Power supply from VDHI pin	5	—	12	
		—	Power supply from VDLI pin	2.5	—	6	
V _{OUT}	Charge Pump Voltage	—	Output to VDHO pin	5	—	12	V
		—	Output to VDLO pin	2.5	—	6	
V _{DHO}	Charge Pump VDH Output Voltage	—	VDH_LV[6:0]=1111111B	-5%	12	+5%	V
V _{DLO}	Charge Pump VDL Output voltage	—	VDL_LV[6:0]=1111111B	-5%	6	+5%	V

Symbol	Parameter	Test Conditions		Min.	Typ.	Max.	Unit
		V _{DD}	Conditions				
I _{DD}	Operating Current	3V	No load, Charge pump On status (V _{DHO} /V _{DLO} non-stable) CPC[1:0]=00B	—	2.526	5.0	mA
		5V		—	4.48	10	
		3V	No load, Charge pump On status (V _{DHO} /V _{DLO} non-stable) CPC[1:0]=01B	—	1.345	3.0	mA
		5V		—	2.285	5.0	
		3V	No load, Charge pump On status (V _{DHO} /V _{DLO} non-stable) CPC[1:0]=10B	—	0.722	1.5	mA
		5V		—	1.076	2.0	
		3V	No load, Charge pump On status (V _{DHO} /V _{DLO} non-stable) CPC[1:0]=11B	—	0.378	1.0	mA
		5V		—	0.609	1.5	
		3V	No load, Charge pump On status (V _{DHO} /V _{DLO} stable)	—	120	180	μA
		5V		—	150	225	
I _{OL}	EPD Segment Sink Current	3V	VDHI pin voltage=12V, SEnG pin V _{OL} =1.2V(n=0~63)	1.0	2.0	—	mA
		5V		1.0	2.0	—	
	EPD COMBG Sink Current	3V	VDHI pin voltage=12V, COMBGm pin V _{OL} =1.2V(m=0~1)	3.0	6.0	—	mA
		5V		3.0	6.0	—	
I _{OH}	EPD Segment Source Current	3V	VDHI pin voltage=12V, SEnG pin V _{OH} =10.8V (n=0~63)	-0.7	-1.5	—	mA
		5V		-0.7	-1.5	—	
	EPD COMBG Source Current	3V	VDHI pin voltage=12V, COMBGm pin V _{OH} =10.8V (m=0~1)	-2.2	-4.5	—	mA
		5V		-2.2	-4.5	—	
t _{RSEG}	Segment Driver Rise Time	—	99% final value, C _{L,S} =30pF, R _{L,S} =10kΩ ^(Note)	—	1	1.5	μs
t _{FSEG}	Segment Driver Fall Time	—	1% final value, C _{L,S} =30pF, R _{L,S} =10kΩ ^(Note)	—	0.8	1.2	μs
t _{RCOMBG}	COMBG Driver Rise Time	—	99% final value, C _{L,COMBG} =2nF, R _{L,COMBG} =1kΩ ^(Note)	—	8	12	μs
t _{FCOMBG}	COMBG Driver Fall Time	—	1% final value, C _{L,COMBG} =2nF, R _{L,COMBG} =1kΩ ^(Note)	—	6	9	μs
t _{CP_READY}	Charge Pump Ready Time	1.8V	f _{SYS} =4MHz, CPC[1:0]=00B	—	350	450	ms
		3V	V _{DHO} from 0V to 12V V _{DLO} from 0V to 6V	—	72	160	ms
		5V	(With VDHO, VDLO output capacitor=1μF)	—	30	64	ms

Note: The EPD drives output RC load.

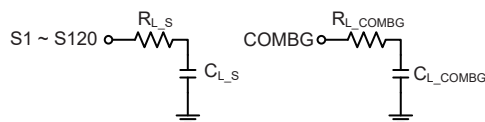

A/D Converter Electrical Characteristics

Ta=-40°C~85°C, unless otherwise specify

Symbol	Parameter	Test Conditions		Min.	Typ.	Max.	Unit
		V _{DD}	Conditions				
AV _{DD}	Operating Voltage	—	—	1.8	—	5.5	V
V _{ADI}	Input Voltage	—	—	0	—	V _{REF}	V
V _{REF}	Reference Voltage	—	—	1.8	—	AV _{DD}	V
DNL	Differential Non-linearity	1.8V	V _{REF} =V _{DD} , t _{ADCK} =0.5μs	-3	—	+3	LSB
		3V					
		5V					
		3V					
5V							
INL	Integral Non-linearity	1.8V	V _{REF} =V _{DD} , t _{ADCK} =0.5μs	-4	—	+4	LSB
		3V					
		5V					
		3V					
5V							
I _{ADC}	Additional Current Consumption for A/D Converter Enable	1.8V	No load, t _{ADCK} =0.5μs	—	280	400	μA
		3V		—	1	2	mA
		5V		—	1.5	3	mA
t _{ADCK}	Clock Period	—	—	0.5	—	10	μs
t _{ON2ST}	A/D Converter On-to-Start Time	—	—	4	—	—	μs
t _{ADS}	Sampling Time	—	—	—	4	—	t _{ADCK}
t _{ADC}	Conversion Time (Including A/D Sample and Hold Time)	—	—	—	16	—	t _{ADCK}
GERR	Gain Error	1.8V	V _{REF} =V _{DD}	-4	—	4	LSB
		3V		-4	—	4	
		5V		-4	—	4	
OSRR	Offset Error	1.8V	V _{REF} =V _{DD}	-4	—	4	LSB
		3V		-4	—	4	
		5V		-4	—	4	

Power-on Reset Characteristics

Ta=25°C

Symbol	Parameter	Test Conditions		Min.	Typ.	Max.	Unit
		V _{DD}	Conditions				
V _{POR}	V _{DD} Start Voltage to Ensure Power-on Reset	—	—	—	—	100	mV
RR _{POR}	V _{DD} Rising Rate to Ensure Power-on Reset	—	—	0.035	—	—	V/ms
t _{POR}	Minimum Time for V _{DD} Stays at V _{POR} to Ensure Power-on Reset	—	—	1	—	—	ms

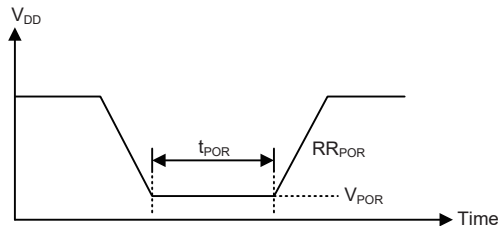

System Architecture

A key factor in the high-performance features of the range of microcontrollers is attributed to their internal system architecture. The device takes advantage of the usual features found within RISC microcontrollers providing increased speed of operation and enhanced performance. The pipelining scheme is implemented in such a way that instruction fetching and instruction execution are overlapped, hence instructions are effectively executed in one or two cycles for most of the standard or extended instructions respectively. The exceptions to this are branch or call instructions which need one more cycle. An 8-bit wide ALU is used in practically all instruction set operations, which carries out arithmetic operations, logic operations, rotation, increment, decrement, branch decisions, etc. The internal data path is simplified by moving data through the Accumulator and the ALU. Certain internal registers are implemented in the Data Memory and can be directly or indirectly addressed. The simple addressing methods of these registers along with additional architectural features ensure that a minimum of external components is required to provide a functional I/O and A/D control system with maximum reliability and flexibility. This makes the device suitable for low-cost, high-volume production for controller applications.

Clocking and Pipelining

The main system clock, derived from either a HIRC, LXT or LIRC oscillator is subdivided into four internally generated non-overlapping clocks, T1~T4. The Program Counter is incremented at the beginning of the T1 clock during which time a new instruction is fetched. The remaining T2~T4 clocks carry out the decoding and execution functions. In this way, one T1~T4 clock cycle forms one instruction cycle. Although the fetching and execution of instructions takes place in consecutive instruction cycles, the pipelining structure of the microcontroller ensures that instructions are effectively executed in one instruction cycle. The exception to this are instructions where the contents of the Program Counter are changed, such as subroutine calls or jumps, in which case the instruction will take one more instruction cycle to execute.

For instructions involving branches, such as jump or call instructions, two machine cycles are required to complete instruction execution. An extra cycle is required as the program takes one cycle to first obtain the actual jump or call address and then another cycle to actually execute the branch. The requirement for this extra cycle should be taken into account by programmers in timing sensitive applications.

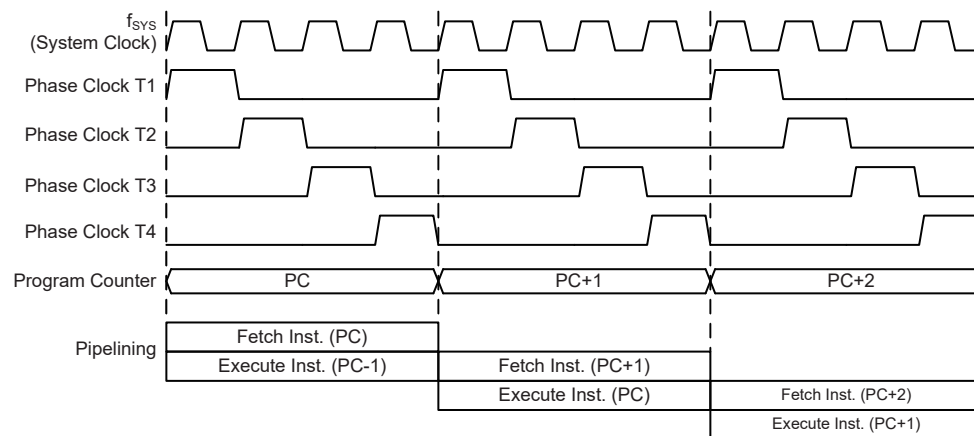

System Clocking and Pipelining

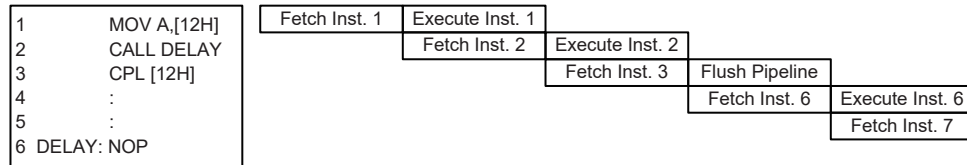

Instruction Fetching

Program Counter

During program execution, the Program Counter is used to keep track of the address of the next instruction to be executed. It is automatically incremented by one each time an instruction is executed except for instructions, such as “JMP” or “CALL” that demands a jump to a non-consecutive Program Memory address. As the device whose memory capacity is greater than 8K words the Program Memory address may be located in a certain program memory bank which is selected by the program memory bank pointer bit PBP0. Only the lower 8 bits, known as the Program Counter Low Register, are directly addressable by the application program.

When executing instructions requiring jumps to non-consecutive addresses such as a jump instruction, a subroutine call, interrupt or reset, etc., the microcontroller manages program control by loading the required address into the Program Counter. For conditional skip instructions, once the condition has been met, the next instruction, which has already been fetched during the present instruction execution, is discarded and a dummy cycle takes its place while the correct instruction is obtained.

Program Counter	
Program Counter High Byte	PCL Register
PBP0, PC12~PC8	PCL7~PCL0

Program Counter

The lower byte of the Program Counter, known as the Program Counter Low register or PCL, is available for program control and is a readable and writeable register. By transferring data directly into this register, a short program jump can be executed directly. However, as only this low byte is available for manipulation, the jumps are limited to the present page of memory, that is 256 locations. When such program jumps are executed it should also be noted that a dummy cycle will be inserted. Manipulating the PCL register may cause program branching, so an extra cycle is needed to pre-fetch.

Stack

This is a special part of the memory which is used to save the contents of the Program Counter only. The stack is organised into 16 levels and is neither part of the data nor part of the program space, and is neither readable nor writeable. The activated level is indexed by the Stack Pointer, and is neither readable nor writeable. At a subroutine call or interrupt acknowledge signal, the contents of the Program Counter are pushed onto the stack. At the end of a subroutine or an interrupt routine, signaled by a return instruction, RET or RETI, the Program Counter is restored to its previous value from the stack. After a device reset, the Stack Pointer will point to the top of the stack.

If the stack is full and an enabled interrupt takes place, the interrupt request flag will be recorded but the acknowledge signal will be inhibited. When the Stack Pointer is decremented, by RET or RETI, the interrupt will be serviced. This feature prevents stack overflow allowing the programmer to use the structure more easily. However, when the stack is full, a CALL subroutine instruction can still be executed which will result in a stack overflow. Precautions should be taken to avoid such cases which might cause unpredictable program branching. If the stack is overflow, the first Program Counter save in the stack will be lost.

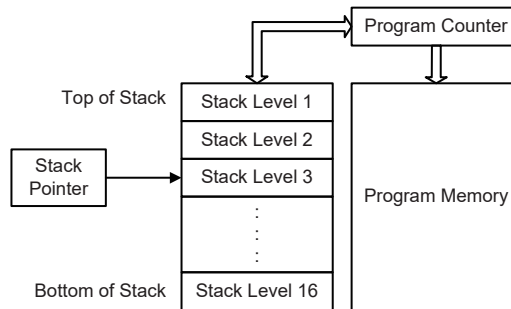

Arithmetic and Logic Unit – ALU

The arithmetic-logic unit or ALU is a critical area of the microcontroller that carries out arithmetic and logic operations of the instruction set. Connected to the main microcontroller data bus, the ALU receives related instruction codes and performs the required arithmetic or logical operations after which the result will be placed in the specified register. As these ALU calculation or operations may result in carry, borrow or other status changes, the status register will be correspondingly updated to reflect these changes. The ALU supports the following functions:

- Arithmetic operations:
 ADD, ADDM, ADC, ADCM, SUB, SUBM, SBC, SBCM, DAA,
 LADD, LADDM, LADC, LADCM, LSUB, LSUBM, LSBC, LSBCM, LDAA
- Logic operations:
 AND, OR, XOR, ANDM, ORM, XORM, CPL, CPLA,
 LAND, LANDM, LOR, LORM, LXOR, LXORM, LCPL, LCPLA
- Rotation:
 RRA, RR, RRCA, RRC, RLA, RL, RLCA, RLC,
 LRR, LRRCA, LRRCA, LRRC, LRLA, LRL, LRLCA, LRLC
- Increment and Decrement:
 INCA, INC, DECA, DEC,
 LINCA, LINC, LDECA, LDEC
- Branch decision:
 JMP, SZ, SZA, SNZ, SIZ, SDZ, SIZA, SDZA, CALL, RET, RETI,
 LSNZ, LSZ, LSZA, LSIZ, LSIZA, LSDZ, LSDZA

Flash Program Memory

The Program Memory is the location where the user code or program is stored. For this device the Program Memory is Flash type, which means it can be programmed and re-programmed a large number of times, allowing the user the convenience of code modification on the same device. By using the appropriate programming tools, the Flash device offer users the flexibility to conveniently debug and develop their applications while also offering a means of field programming and updating.

Structure

The Program Memory has a capacity of 16K×16 bits. The Program Memory is addressed by the Program Counter and also contains data, table information and interrupt entries. Table data, which can be setup in any location within the Program Memory, is addressed by a separate table pointer register.

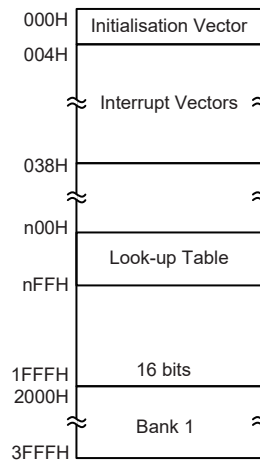

Program Memory Structure

Special Vectors

Within the Program Memory, certain locations are reserved for the reset and interrupts. The location 000H is reserved for use by the device reset for program initialisation. After a device reset is initiated, the program will jump to this location and begin execution.

Look-up Table

Any location within the Program Memory can be defined as a look-up table where programmers can store fixed data. To use the look-up table, the table pointer must first be setup by placing the address of the look up data to be retrieved in the table pointer register, TBLP and TBHP. These registers define the total address of the look-up table.

After setting up the table pointer, the table data can be retrieved from the Program Memory using the corresponding table read instruction such as “TABRD [m]” or “TABRDL [m]” respectively when the memory [m] is located in Sector 0. If the memory [m] is located in other sectors, the data can be retrieved from the program memory using the corresponding extended table read instruction such as “LTABRD [m]” or “LTABRDL [m]” respectively. When the instruction is executed, the lower order table byte from the Program Memory will be transferred to the user defined Data Memory register [m] as specified in the instruction. The higher order table data byte from the Program Memory will be transferred to the TBLH special register. Any unused bits in this transferred higher order byte will be read as “0”.

The accompanying diagram illustrates the addressing data flow of the look-up table.

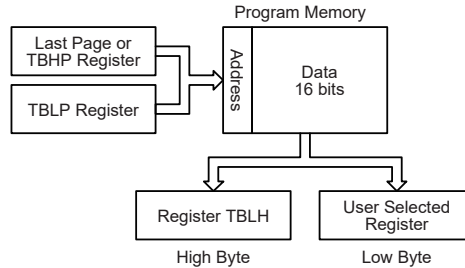

Table Program Example

The following example shows how the table pointer and table data is defined and retrieved from the microcontroller. This example uses raw table data located in the Program Memory which is stored there using the ORG statement. The value at this ORG statement is “1F00H” which is located in ROM Bank 1 and refers to the start address of the last page within the 16K Program Memory of the microcontroller. The table pointer low byte register is setup here to have an initial value of “06H”. This will ensure that the first data read from the data table will be at the Program Memory address “3F06H” or 6 locations after the start of the last page. Note that the value for the table pointer is referenced to the specific address pointed by TBLP and TBHP registers if the “TABRD [m]” or “LTABRD [m]” instruction is being used. The high byte of the table data which in this case is equal to zero will be transferred to the TBLH register automatically when the “TABRD [m]” or “LTABRD [m]” instruction is executed.

Because the TBLH register is a read/write register and can be restored, care should be taken to ensure its protection if both the main routine and Interrupt Service Routine use table read instructions. If using the table read instructions, the Interrupt Service Routines may change the value of the TBLH and subsequently cause errors if used again by the main routine. As a rule it is recommended that simultaneous use of the table read instructions should be avoided. However, in situations where simultaneous use cannot be avoided, the interrupts should be disabled prior to the execution of any main routine table-read instructions. Note that all table related instructions require two instruction cycles to complete their operation.

Table Read Program Example

```

rombank 1 code1
ds .section 'data'
tempreg1 db ? ; temporary register #1
tempreg2 db ? ; temporary register #2
:
:
code0 .section 'code'
mov a,06h ; initialise low table pointer - note that this address is referenced
mov tblp,a ; to the last page or the page that tbhp pointed
mov a,3Fh ; initialise high table pointer
mov tbhp,a ; It is not necessary to set tbhp register if executing "tabrdl"
; instruction
:
:
tabrd tempreg1 ; transfers value in table referenced by table pointer data at program
; memory address "3F06H" transferred to tempreg1 and TBLH
dec tblp ; reduce value of table pointer by one
tabrd tempreg2 ; transfers value in table referenced by table pointer
; data at program memory address "3F05H" transferred to
; tempreg2 and TBLH in this example the data "1AH" is
; transferred to tempreg1 and data "0FH" to register tempreg2
  
```

```

:
:
:
code1 .section 'code'
org 1F00h          ; sets initial address of program memory
dc 00Ah, 00Bh, 00Ch, 00Dh, 00Eh, 00Fh, 01Ah, 01Bh
:
:

```

In Circuit Programming – ICP

The provision of Flash type Program Memory provides the user with a means of convenient and easy upgrades and modifications to their programs on the same device. As an additional convenience, Holtek has provided a means of programming the microcontroller in-circuit using a 4-pin interface. This provides manufacturers with the possibility of manufacturing their circuit boards complete with a programmed or un-programmed microcontroller, and then programming or upgrading the program at a later stage. This enables product manufacturers to easily keep their manufactured products supplied with the latest program releases without removal and re-insertion of the device.

The Flash MCU to Writer Programming Pin correspondence table is as follows:

Holtek Writer Pins	MCU Programming Pins	Pin Description
ICPDA	PA0	Programming serial data/address
ICPCK	PA2	Programming clock
VDD	VDD/AVDD	Power supply
VSS	VSS/AVSS	Ground

The Program Memory can be programmed serially in-circuit using this 4-wire interface. Data is downloaded and uploaded serially on a single pin with an additional line for the clock. Two additional lines are required for the power supply. The technical details regarding the in-circuit programming of the device are beyond the scope of this document and will be supplied in supplementary literature.

During the programming process, the user must take care of the ICPDA and ICPCK pins for data and clock programming purposes to ensure that no other outputs are connected to these two pins.

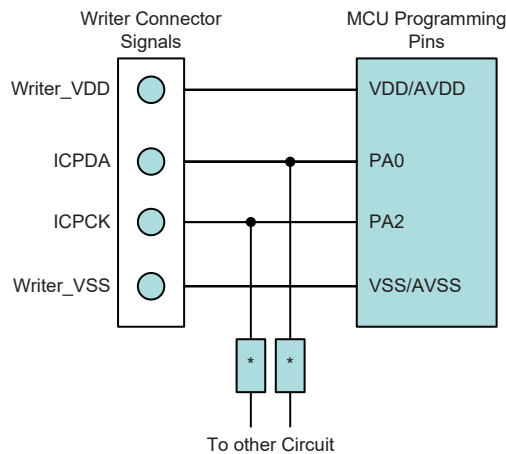

Note: * may be resistor or capacitor. The resistance of * must be greater than 1kΩ or the capacitance of * must be less than 1nF.

On-Chip Debug Support – OCDS

There is an EV chip named HT67V2567 which is used to emulate the real MCU device named HT67F2567. This EV chip device also provides an “On-Chip Debug” function to debug the device during the development process. The EV chip and the actual MCU device are almost functionally compatible except for the “On-Chip Debug” function. Users can use the EV chip device to emulate the real chip device behavior by connecting the OCSDSA and OCDSCK pins to the HT-IDE development tools. The OCSDSA pin is the OCDS Data/Address input/output pin while the OCDSCK pin is the OCDS clock input pin. When users use the EV chip for debugging, other functions which are shared with the OCSDSA and OCDSCK pins in the actual MCU device will have no effect in the EV chip. However, the two OCDS pins which are pin-shared with the ICP programming pins are still used as the Flash Memory programming pins for ICP. For a more detailed OCDS description, refer to the corresponding document named “Holtek e-Link for 8-bit MCU OCDS User’s Guide”.

Holtek e-Link Pins	EV Chip Pins	Pin Description
OCSDSA	OCSDSA	On-chip debug support data/address input/output
OCDSCK	OCDSCK	On-chip debug support clock input
VDD	VDD/AVDD	Power supply
VSS	VSS/AVSS	Ground

In Application Programming – IAP

Flash type Program Memory provides the user with a means of convenient and easy upgrades and modifications to their programs on the same device. The provision of IAP function offers users the convenience of Flash Memory multi-programming features. The convenience of the IAP function is that it can execute the updated program procedure using its internal firmware, without requiring an external Program Writer or PC. In addition, the IAP interface can also be any type of communication protocol, such as UART, using I/O pins. Regarding the internal firmware, the user can select versions provided by Holtek or create their own. The following section illustrates the procedures regarding how to implement the IAP firmware.

Flash Memory Read/Write Size

The flash memory Erase and Write operations are carried out in a page format while the Read operation is carried out in a word format. The page size and write buffer size are both assigned with a capacity of 64 words. Note that the Erase operation should be executed before the Write operation is executed.

When the Flash Memory Erase/Write Function is successfully enabled, the CFWEN bit will be set high. When the CFWEN bit is set high, the data can be written into the write buffer. The FWT bit is used to initiate the write process and then indicate the write operation status. This bit is set high by application programs to initiate a write process and will be cleared by hardware if the write process is finished.

The Read operation can be carried out by executing a specific read procedure. The FRDEN bit is used to enable the read function and the FRD bit is used to initiate the read process by application programs and then indicate the read operation status. When the read process is finished, this bit will be cleared by hardware.

Operations	Format
Erase	64 words/page
Write	64 words/time
Read	1 word/time

Note: Page size=Write buffer size=64 words.

IAP Read/Write Format

Erase Page	FARH	FARL [7:6]	FARL [5:0]
0	0000 0000	00	xx xxxx
1	0000 0000	01	xx xxxx
2	0000 0000	10	xx xxxx
3	0000 0000	11	xx xxxx
4	0000 0001	00	xx xxxx
:	:	:	:
:	:	:	:
254	0011 1111	10	xx xxxx
255	0011 1111	11	xx xxxx

"x": don't care

Erase Page Number and Selection

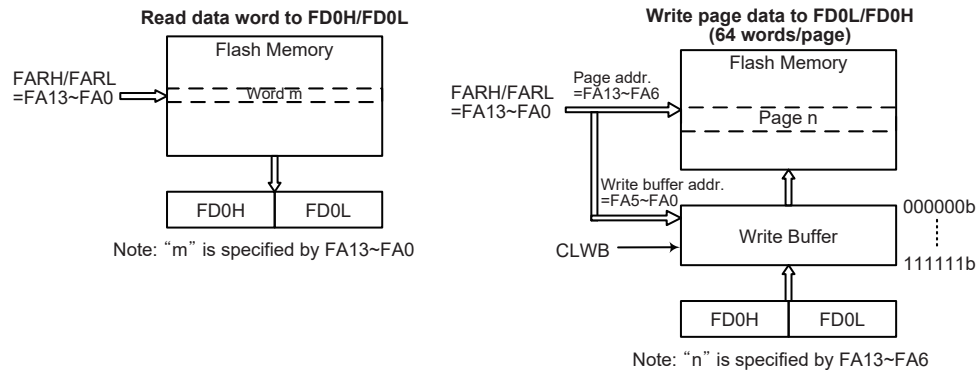

Flash Memory IAP Read/Write Structure

Write Buffer

The write buffer is used to store the written data temporarily when executing the write operation. The Write Buffer can be filled with written data after the Flash Memory Erase/Write Function has been successfully enabled by executing the Flash Memory Erase/Write Function Enable procedure. The write buffer can be cleared by configuring the CLWB bit in the FC2 register. The CLWB bit can be set high to enable the Clear Write Buffer procedure. When the procedure is finished this bit will be cleared to low by the hardware. It is recommended that the write buffer should be cleared by setting the CLWB bit high before the write buffer is used for the first time or when the data in the write buffer is updated.

The write buffer size is 64 words corresponding to a page. The write buffer address is mapped to a specific flash memory page specified by the memory address bits, FA13~FA6. The data written into the FD0L and FD0H registers will be loaded into the write buffer. When data is written into the high byte data register, FD0H, it will result in the data stored in the high and low byte data registers both being written into the write buffer. It will also cause the flash memory address to be incremented by one, after which the new address will be loaded into the FARH and FARL address registers. When the flash memory address reaches the page boundary, 111111b of a page with 64 words, the address will now not be incremented but will stop at the last address of the page. At this point a new page address should be specified for any other erase/write operations.

After a write process is finished, the write buffer will automatically be cleared by the hardware. Note that the write buffer should be cleared manually by the application program when the data written into the flash memory is incorrect in the data verification step. The data should again be written into the write buffer after the write buffer has been cleared when the data is found to be incorrect during the data verification step.

IAP Flash Program Memory Registers

There are two address registers, four 16-bit data registers and three control registers. The address and data register pairs are located in Sector 0 while the control registers are located in Sector 1. Read and Write operations to the Flash memory are carried out using 16-bit data operations using the address and data registers and the control register. Several registers control the overall operation of the internal Flash Program Memory. The address registers are named FARL and FARH, the data registers are named FDnL and FDnH and the control registers are named FC0, FC1 and FC2. As the address and data register pairs are located in Sector 0, they can be directly accessed in the same way as any other Special Function Register. The control registers, being located in Sector 1, can be addressed directly only using the corresponding extended instructions or can be read from or written to indirectly using the MP1H/MP1L or MP2H/MP2L Memory Pointer pairs and Indirect Addressing Register, IAR1 or IAR2.

Register Name	Bit							
	7	6	5	4	3	2	1	0
FC0	CFWEN	FMOD2	FMOD1	FMOD0	FWPEN	FWT	FRDEN	FRD
FC1	D7	D6	D5	D4	D3	D2	D1	D0
FC2	—	—	—	—	—	—	—	CLWB
FARL	FA7	FA6	FA5	FA4	FA3	FA2	FA1	FA0
FARH	—	—	FA13	FA12	FA11	FA10	FA9	FA8
FD0L	D7	D6	D5	D4	D3	D2	D1	D0
FD0H	D15	D14	D13	D12	D11	D10	D9	D8
FD1L	D7	D6	D5	D4	D3	D2	D1	D0
FD1H	D15	D14	D13	D12	D11	D10	D9	D8
FD2L	D7	D6	D5	D4	D3	D2	D1	D0
FD2H	D15	D14	D13	D12	D11	D10	D9	D8
FD3L	D7	D6	D5	D4	D3	D2	D1	D0
FD3H	D15	D14	D13	D12	D11	D10	D9	D8

IAP Register List

• FARL Register

Bit	7	6	5	4	3	2	1	0
Name	FA7	FA6	FA5	FA4	FA3	FA2	FA1	FA0
R/W	R/W	R/W	R/W	R/W	R/W	R/W	R/W	R/W
POR	0	0	0	0	0	0	0	0

Bit 7~0 **FA7~FA0**: Flash Memory Address bit 7~bit 0

• FARH Register

Bit	7	6	5	4	3	2	1	0
Name	—	—	FA13	FA12	FA11	FA10	FA9	FA8
R/W	—	—	R/W	R/W	R/W	R/W	R/W	R/W
POR	—	—	0	0	0	0	0	0

Bit 7~6 Unimplemented, read as 0

Bit 5~0 **FA13~FA8**: Flash Memory Address bit 13~bit 8

• **FD0L Register**

Bit	7	6	5	4	3	2	1	0
Name	D7	D6	D5	D4	D3	D2	D1	D0
R/W	R/W	R/W	R/W	R/W	R/W	R/W	R/W	R/W
POR	0	0	0	0	0	0	0	0

Bit 7~0 **D7~D0**: The first Flash Memory data word bit 7~bit 0
 Note that data written into the low byte data register FD0L will only be stored in the FD0L register and not loaded into the lower 8-bit write buffer.

• **FD0H Register**

Bit	7	6	5	4	3	2	1	0
Name	D15	D14	D13	D12	D11	D10	D9	D8
R/W	R/W	R/W	R/W	R/W	R/W	R/W	R/W	R/W
POR	0	0	0	0	0	0	0	0

Bit 7~0 **D15~D8**: The first Flash Memory data word bit 15~bit 8
 Note that when 8-bit data is written into the high byte data register FD0H, the whole 16-bits of data stored in the FD0H and FD0L registers will simultaneously be loaded into the 16-bit write buffer after which the contents of the Flash memory address register pair, FARH and FARL, will be incremented by one.

• **FD1L Register**

Bit	7	6	5	4	3	2	1	0
Name	D7	D6	D5	D4	D3	D2	D1	D0
R/W	R/W	R/W	R/W	R/W	R/W	R/W	R/W	R/W
POR	0	0	0	0	0	0	0	0

Bit 7~0 **D7~D0**: The second Flash Memory data word bit 7~bit 0

• **FD1H Register**

Bit	7	6	5	4	3	2	1	0
Name	D15	D14	D13	D12	D11	D10	D9	D8
R/W	R/W	R/W	R/W	R/W	R/W	R/W	R/W	R/W
POR	0	0	0	0	0	0	0	0

Bit 7~0 **D15~D8**: The second Flash Memory data word bit 15~bit 8

• **FD2L Register**

Bit	7	6	5	4	3	2	1	0
Name	D7	D6	D5	D4	D3	D2	D1	D0
R/W	R/W	R/W	R/W	R/W	R/W	R/W	R/W	R/W
POR	0	0	0	0	0	0	0	0

Bit 7~0 **D7~D0**: The third Flash Memory data word bit 7~bit 0

• **FD2H Register**

Bit	7	6	5	4	3	2	1	0
Name	D15	D14	D13	D12	D11	D10	D9	D8
R/W	R/W	R/W	R/W	R/W	R/W	R/W	R/W	R/W
POR	0	0	0	0	0	0	0	0

Bit 7~0 **D15~D8**: The third Flash Memory data word bit 15~bit 8

• **FD3L Register**

Bit	7	6	5	4	3	2	1	0
Name	D7	D6	D5	D4	D3	D2	D1	D0
R/W	R/W	R/W	R/W	R/W	R/W	R/W	R/W	R/W
POR	0	0	0	0	0	0	0	0

Bit 7~0 **D7~D0**: The fourth Flash Memory data word bit 7~bit 0

• **FD3H Register**

Bit	7	6	5	4	3	2	1	0
Name	D15	D14	D13	D12	D11	D10	D9	D8
R/W	R/W	R/W	R/W	R/W	R/W	R/W	R/W	R/W
POR	0	0	0	0	0	0	0	0

Bit 7~0 **D15~D8**: The fourth Flash Memory data word bit 15~bit 8

• **FC0 Register**

Bit	7	6	5	4	3	2	1	0
Name	CFWEN	FMOD2	FMOD1	FMOD0	FWPEN	FWT	FRDEN	FRD
R/W	R/W	R/W	R/W	R/W	R/W	R/W	R/W	R/W
POR	0	0	0	0	0	0	0	0

Bit 7 **CFWEN**: Flash Memory Erase/Write function enable control

0: Flash memory erase/write function is disabled

1: Flash memory erase/write function has been successfully enabled

When this bit is cleared to 0 by application program, the Flash memory erase/write function is disabled. Note that this bit cannot be set high by application programs. Writing “1” into this bit results in no action. This bit is used to indicate the Flash memory erase/write function status. When this bit is set to 1 by the hardware, it means that the Flash memory erase/write function is enabled successfully. Otherwise, the Flash memory erase/write function is disabled if the bit is zero.

Bit 6~4 **FMOD2~FMOD0**: Flash memory Mode selection

000: Write Mode

001: Page erase Mode

010: Reserved

011: Read Mode

100: Reserved

101: Reserved

110: Flash memory Erase/Write function Enable Mode

111: Reserved

These bits are used to select the Flash Memory operation modes. Note that the “Flash memory Erase/Write function Enable Mode” should first be successfully enabled before the Erase or Write Flash memory operation is executed.

Bit 3 **FWPEN**: Flash memory Erase/Write function enable procedure Trigger

0: Erase/Write function enable procedure is not triggered or procedure timer times out

1: Erase/Write function enable procedure is triggered and procedure timer starts to count

This bit is used to activate the flash memory Erase/Write function enable procedure and an internal timer. It is set by the application programs and then cleared to zero by the hardware when the internal timer times out. The correct patterns must be written into the FD1L/FD1H, FD2L/FD2H and FD3L/FD3H register pairs respectively as soon as possible after the FWPEN bit is set high.

- Bit 2 **FWT**: Flash memory write initiate control
 0: Do not initiate Flash memory write or indicating that a Flash memory write process has completed
 1: Initiate Flash memory write process
 This bit is set by software and cleared to zero by the hardware when the Flash memory write process has completed. Note that all CPU operations will be stopped when this bit is set to 1.
- Bit 1 **FRDEN**: Flash memory read enable control
 0: Flash memory read disable
 1: Flash memory read enable
 This is the Flash memory Read Enable Bit which must be set high before any Flash memory read operations are carried out. Clearing this bit to zero will inhibit Flash memory read operations.
- Bit 0 **FRD**: Flash memory read initiate control
 0: Do not initiate Flash memory read or indicating that a Flash memory read process has completed
 1: Initiate Flash memory read process
 This bit is set by software and cleared to zero by the hardware when the Flash memory read process has completed. Note that all CPU operations will be stopped when this bit is set to 1.

- Note: 1. The FWT, FRDEN and FRD bits cannot be set to “1” at the same time with a single instruction.
 2. Ensure that the f_{SUB} clock is stable before executing the erase/write operation.
 3. Ensure that the read/erase/write operation is totally complete before executing other operations.

• **FC1 Register**

Bit	7	6	5	4	3	2	1	0
Name	D7	D6	D5	D4	D3	D2	D1	D0
R/W	R/W	R/W	R/W	R/W	R/W	R/W	R/W	R/W
POR	0	0	0	0	0	0	0	0

- Bit 7~0 **D7~D0**: Chip Reset Pattern
 When a specific value of “55H” is written into this register, a reset signal will be generated to reset the whole chip.

• **FC2 Register**

Bit	7	6	5	4	3	2	1	0
Name	—	—	—	—	—	—	—	CLWB
R/W	—	—	—	—	—	—	—	R/W
POR	—	—	—	—	—	—	—	0

- Bit 7~1 Unimplemented, read as “0”.
- Bit 0 **CLWB**: Flash memory Write Buffer Clear control
 0: Do not initiate a Write Buffer Clear process or indicating that a Write Buffer Clear process has completed.
 1: Initiate Write Buffer Clear process
 This bit is set by software and cleared to zero by hardware when the Write Buffer Clear process has completed.

Flash Memory Erase/Write Flow

It is important to understand the Flash memory Erase/Write flow before the Flash memory contents are updated. Users can refer to the corresponding operation procedures when developing their IAP program to ensure that the flash memory contents are correctly updated.

Flash Memory Erase/Write Flow Descriptions:

1. Activate the “Flash Memory Erase/Write function enable procedure” first. When the Flash Memory Erase/Write function is successfully enabled, the CFWEN bit in the FC0 register will automatically be set high by hardware. After this, Erase or Write operations can be executed on the Flash memory. Refer to the “Flash Memory Erase/Write Function Enable Procedure” for details.
2. Configure the flash memory address to select the desired erase page and then erase this page.
3. Execute a Blank Check operation to ensure whether the page erase operation is successful or not. The “TABRD” instruction should be executed to read the flash memory contents and to check if the contents is 0000h or not. If the flash memory page erase operation fails, users should go back to Step 2 and execute the page erase operation again.
4. Write data into the specific page. Refer to the “Flash Memory Write Procedure” for details.
5. Execute the “TABRD” instruction to read the flash memory contents and check if the written data is correct or not. If the data read from the flash memory is different from the written data, it means that the page write operation has failed. The CLWB bit should be set high to clear the write buffer and then write the data into the specific page again if the write operation has failed.
6. Clear the CFWEN bit to disable the Flash Memory Erase/Write function enable mode if the current page Erase and Write operations are complete if no more pages need to be erased or written.

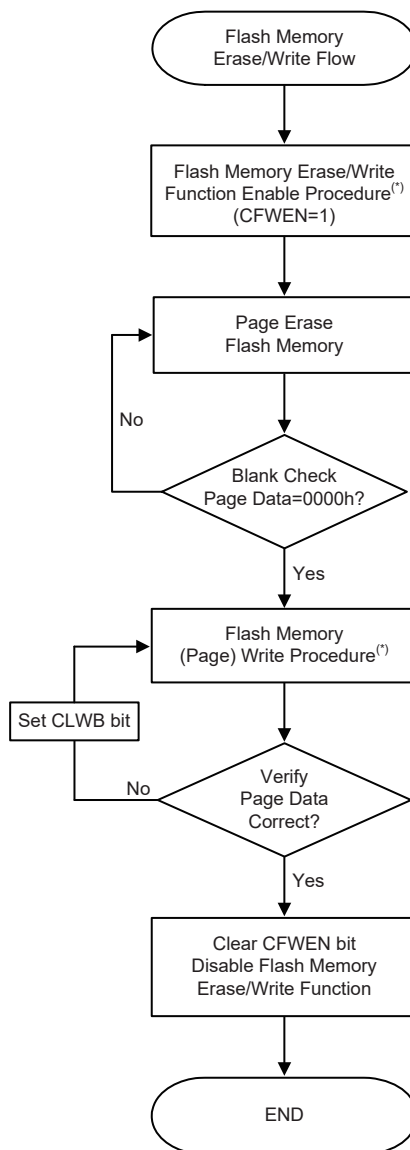

Flash Memory Erase/Write Flow

Note: The Flash Memory Erase/Write Function Enable procedure and Flash Memory Write procedure will be described in the following sections.

Flash Memory Erase/Write Function Enable Procedure

The Flash Memory Erase/Write Function Enable Mode is specially designed to prevent the flash memory contents from being wrongly modified. In order to allow users to change the Flash memory data using the IAP control registers, users must first enable the Flash memory Erase/Write function.

Flash Memory Erase/Write Function Enable Procedure Description

1. Write data “110” to the FMOD [2:0] bits in the FC0 register to select the Flash Memory Erase/Write Function Enable Mode.
2. Set the FWPEN bit in the FC0 register to “1” to activate the Flash Memory Erase/Write Function. This will also activate an internal timer.
3. Write the correct data pattern into the Flash data registers, FD1L~FD3L and FD1H~FD3H, as soon as possible after the FWPEN bit is set high. The enable Flash memory erase/write function data pattern is 00H, 0DH, C3H, 04H, 09H and 40H corresponding to the FD1L~FD3L and FD1H~FD3H registers respectively.
4. Once the timer has timed out, the FWPEN bit will automatically be cleared to 0 by hardware regardless of the input data pattern.
5. If the written data pattern is incorrect, the Flash memory erase/write function will not be enabled successfully and the above steps should be repeated. If the written data pattern is correct, the Flash memory erase/write function will be enabled successfully.
6. Once the Flash memory erase/write function is enabled, the Flash memory contents can be updated by executing the page erase and write operations using the IAP control registers.

To disable the Flash memory erase/write function, the CFWEN bit in the FC0 register can be cleared. There is no need to execute the above procedure.

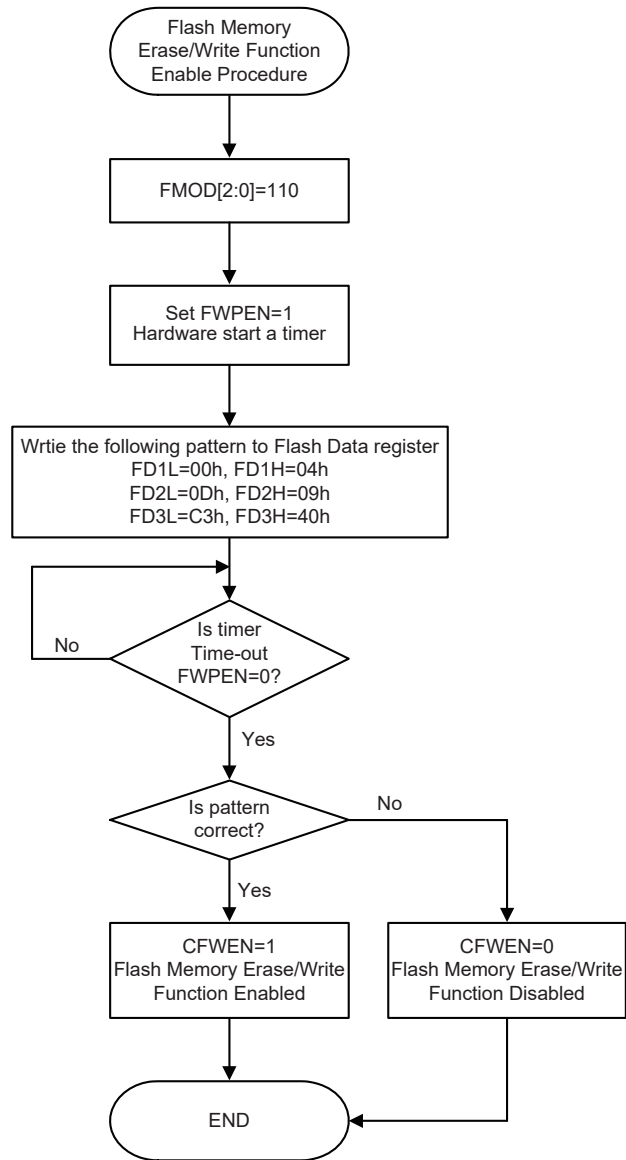

Flash Memory Erase/Write Function Enable Procedure

Flash Memory Write Procedure

After the Flash memory erase/write function has been successfully enabled as the CFWEN bit is set high, the data to be written into the flash memory can be loaded into the write buffer. The selected flash memory page data should be erased by properly configuring the IAP control registers before the data write procedure is executed.

The write buffer size is 64 words, known as a page, whose address is mapped to a specific flash memory page specified by the memory address bits, FA13~FA6. It is important to ensure that the page where the write buffer data is located is the same one which the memory address bits, FA13~FA6, specify.

Flash Memory Consecutive Write Description

The maximum amount of write data is 64 words for each write operation. The write buffer address will be automatically incremented by one when consecutive write operations are executed. The start address of a specific page should first be written into the FARL and FARH registers. Then the data word should first be written into the FD0L register and then the FD0H register. At the same time the write buffer address will be incremented by one and then the next data word can be written into the FD0L and FD0H registers for the next address without modifying the address register pair, FARH and FARL. When the write buffer address reaches the page boundary the address will not be further incremented but will stop at the last address of the page.

1. Activate the “Flash Memory Erase/Write function enable procedure”. Check the CFWEN bit value and then execute the erase/write operations if the CFWEN bit is set high. Refer to the “Flash Memory Erase/Write function enable procedure” for more details.
2. Set the FMOD field to “001” to select the erase operation. Set the FWT bit high to erase the desired page which is specified by the FARH and FARL registers. Wait until the FWT bit goes low.
3. Execute a Blank Check operation using the table read instruction to ensure that the erase operation has successfully completed.
Go to step 2 if the erase operation is not successful.
Go to step 4 if the erase operation is successful.
4. Set the FMOD field to “000” to select the write operation.
5. Setup the desired start address in the FARH and FARL registers. Write the desired data words consecutively into the FD0L and FD0H registers within a page as specified by their consecutive addresses. The maximum written data number is 64 words.
6. Set the FWT bit high to write the data words from the write buffer to the flash memory. Wait until the FWT bit goes low.
7. Verify the data using the table read instruction to ensure that the write operation has successfully completed.
If the write operation has not successfully completed, set the CLWB bit high to clear the write buffer and then go to step 5.
Go to step 8 if the write operation is successful.
8. Clear the CFWEN bit low to disable the Flash memory erase/write function.

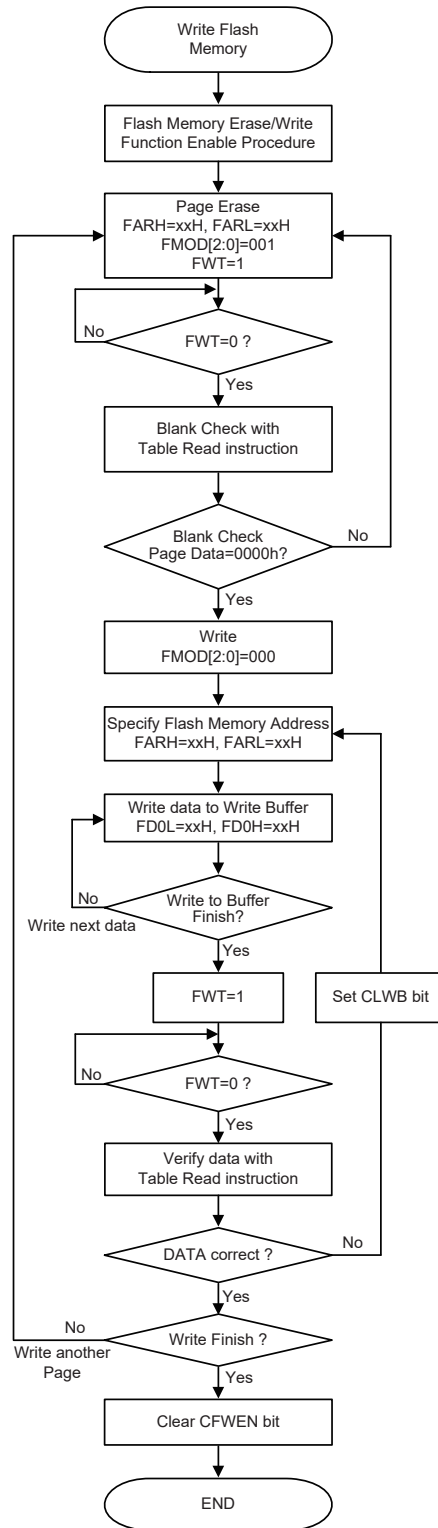

Flash Memory Consecutive Write Procedure

- Note: 1. When the FWT bit is set to 1 all CPU operations will temporarily cease.
2. It will take a typical time of 2.2ms for the FWT bit state changing from high to low.

Flash Memory Non-Consecutive Write Description

The main difference between Flash Memory Consecutive and Non-Consecutive Write operations is whether the data words to be written are located in consecutive addresses or not. If the data to be written is not located in consecutive addresses the desired address should be re-assigned after a data word is successfully written into the Flash Memory.

A two data word non-consecutive write operation is taken as an example here and described as follows:

1. Activate the “Flash Memory Erase/Write function enable procedure”. Check the CFWEN bit value and then execute the erase/write operation if the CFWEN bit is set high. Refer to the “Flash Memory Erase/Write function enable procedure” for more details.
2. Set the FMOD field to “001” to select the erase operation. Set the FWT bit high to erase the desired page which is specified by the FARH and FARL registers. Wait until the FWT bit goes low.
3. Execute a Blank Check operation using the table read instruction to ensure that the erase operation has successfully completed.

Go to step 2 if the erase operation is not successful.

Go to step 4 if the erase operation is successful.

4. Set the FMOD field to “000” to select the write operation.
5. Setup the desired address ADDR1 in the FARH and FARL registers. Write the desired data word DATA1 first into the FD0L register and then into the FD0H register.
6. Set the FWT bit high to transfer the data word from the write buffer to the flash memory. Wait until the FWT bit goes low.
7. Verify the data using the table read instruction to ensure that the write operation has successfully completed.

If the write operation has not successfully completed, set the CLWB bit high to clear the write buffer and then go to step 5.

Go to step 8 if the write operation is successful.

8. Setup the desired address ADDR2 in the FARH and FARL registers. Write the desired data word DATA2 first into the FD0L register and then into the FD0H register.
9. Set the FWT bit high to transfer the data word from the write buffer to the flash memory. Wait until the FWT bit goes low.
10. Verify the data using the table read instruction to ensure that the write operation has successfully completed.

If the write operation has not successfully completed, set the CLWB bit high to clear the write buffer and then go to step 8.

Go to step 11 if the write operation is successful.

11. Clear the CFWEN bit low to disable the Flash memory erase/write function.

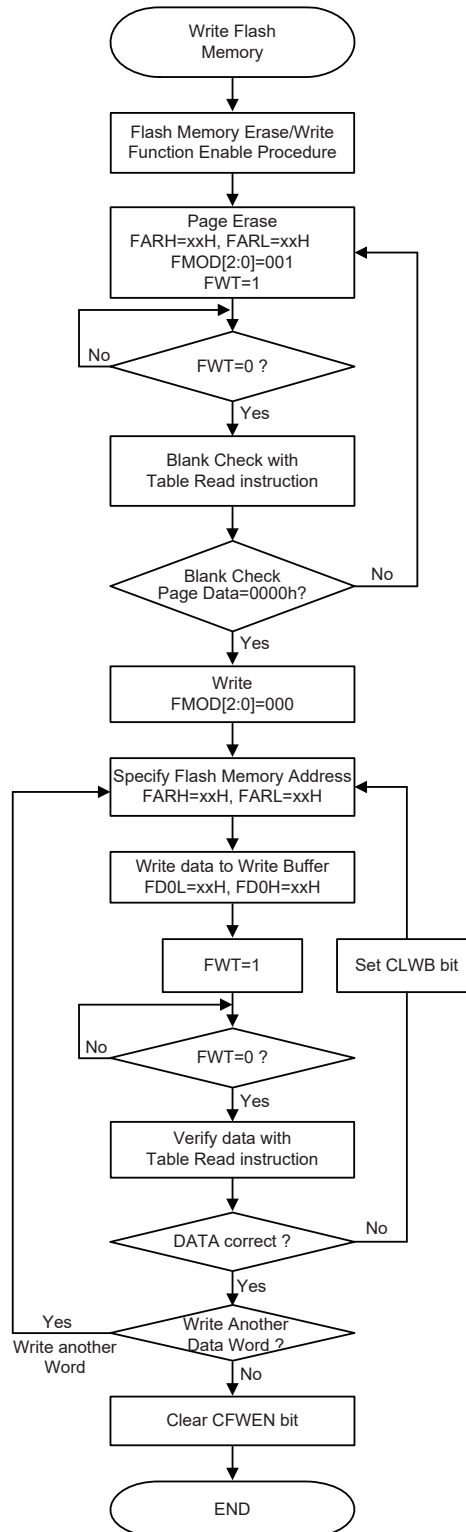

Flash Memory Non-Consecutive Write Procedure

- Note: 1. When the FWT bit is set to high all CPU operations will temporarily cease.
2. It will take a typical time of 2.2ms for the FWT bit state changing from high to low.

Important Points to Note for Flash Memory Write Operations

1. The “Flash Memory Erase/Write Function Enable Procedure” must be successfully activated before the Flash Memory erase/write operation is executed.
2. The Flash Memory erase operation is executed to erase a whole page.
3. The whole write buffer data will be written into the flash memory in a page format. The corresponding address cannot exceed the page boundary.
4. After the data is written into the flash memory the flash memory contents must be read out using the table read instruction, TABRD, and checked if it is correct or not. If the data written into the flash memory is incorrect, the write buffer should be cleared by setting the CLWB bit high and then writing the data again into the write buffer. Then activate a write operation on the same flash memory page without erasing it. The data check, buffer clear and data re-write steps should be repeatedly executed until the data written into the flash memory is correct.
5. The system frequency should be setup to the maximum application frequency when data write and data check operations are executed using the IAP function.

Flash Memory Read Procedure

To activate the Flash Memory Read procedure, the FMOD field should be set to “011” to select the flash memory read mode and the FRDEN bit should be set high to enable the read function. The desired flash memory address should be written into the FARH and FARL registers and then the FRD bit should be set high. After this the flash memory read operation will be activated. The data stored in the specified address can be read from the data registers, FD0H and FD0L, when the FRD bit goes low. There is no need to first activate the Flash Memory Erase/Write Function Enable Procedure before the flash memory read operation is executed.

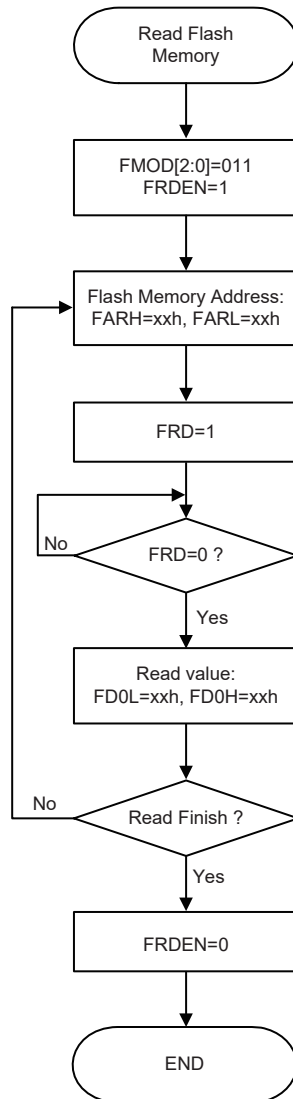

Flash Memory Read Procedure

- Note: 1. When the FRD bit is set to high all CPU operations will temporarily cease.
2. It will take a typical time of three instruction cycles for the FRD bit state changing from high to low.

Data Memory

The Data Memory is a volatile area of 8-bit wide RAM internal memory and is the location where temporary information is stored.

Categorized into two types, the first of these is an area of RAM where special function registers are located. These registers have fixed locations and are necessary for correct operation of the device. Many of these registers can be read from and written to directly under program control, however, some remain protected from user manipulation. The second area of Data Memory is reserved for general purpose use. All locations within this area are read and write accessible under program control.

Switching between the different Data Memory sectors can be achieved by properly setting the Memory Pointers to correct value.

Structure

The Data Memory is subdivided into several sectors, all of which are implemented in 8-bit wide Memory. Each of the Data Memory Sector is categorized into two types, the special Purpose Data Memory and the General Purpose Data Memory. The address range of the Special Purpose Data Memory for the device is from 00H to 7FH while the General Purpose Data Memory address range is from 80H to FFH.

Special Purpose Data Memory	General Purpose Data Memory	
Available Sectors	Capacity	Sector: Address
0~3	2304×8	0: 80H~FFH 1: 80H~FFH ⋮ 17: 80H~FFH

Data Memory Summary

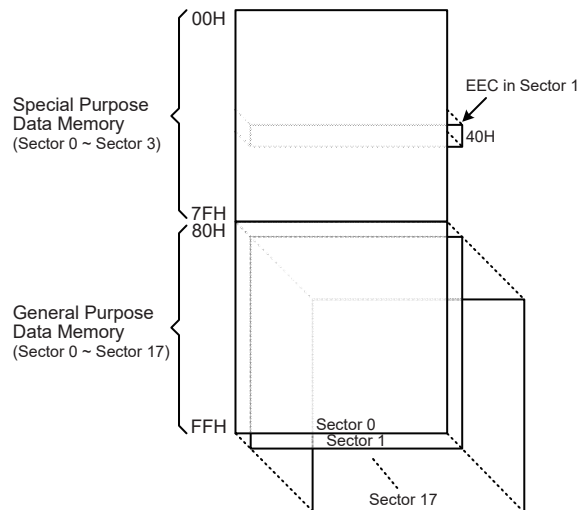

Data Memory Structure

Data Memory Addressing

For device that supports the extended instructions, there is no Bank Pointer for Data Memory. The Bank Pointer, PBP, is only available for Program Memory. For Data Memory the desired Sector is pointed by the MP1H or MP2H register and the certain Data Memory address in the selected sector is specified by the MP1L or MP2L register when using indirect addressing access.

Direct Addressing can be used in all sectors using the corresponding instruction which can address all available data memory space. For the accessed data memory which is located in any data memory sectors except sector 0, the extended instructions can be used to access the data memory instead of using the indirect addressing access. The main difference between standard instructions and extended instructions is that the data memory address “m” in the extended instructions can be 13 valid bits for the device, the high byte indicates a sector and the low byte indicates a specific address.

General Purpose Data Memory

All microcontroller programs require an area of read/write memory where temporary data can be stored and retrieved for use later. It is this area of RAM memory that is known as General Purpose Data Memory. This area of Data Memory is fully accessible by the user programing for both reading and writing operations. By using the bit operation instructions individual bits can be set or reset under program control giving the user a large range of flexibility for bit manipulation in the Data Memory.

Special Purpose Data Memory

This area of Data Memory is where registers, necessary for the correct operation of the microcontroller, are stored. Most of the registers are both readable and writeable but some are protected and are readable only, the details of which are located under the relevant Special Function Register section. Note that for locations that are unused, any read instruction to these addresses will return the value “00H”.

	Sector 0	Sector 1	Sector 2	Sector 3		Sector 0	Sector 1	Sector 2	Sector 3
00H	IAR0		EPDC0	PEPD0	40H	LVDC		PHS4_WK	
01H	MP0		EPDC1	PEPD1	41H	EEA		LVL0_WW1	
02H	IAR1		EPDC2	PEPD2	42H			LVL0_WW2	
03H	MP1L		VDL LV	PEPD3	43H	EED	FC0	PHS0_WW	
04H	MP1H		LVL0 V1	PEPD4	44H		FC1	LVL1_WW1	
05H	ACC		LVL0 V2	PEPD5	45H		FC2	LVL1_WW2	
06H	PCL		LVL0 V	PEPD6	46H	PAS0		PHS1_WW	
07H	TBLP		LVL1 V1	PEPD7	47H	PAS1		LVL2_WW1	
08H	TBLH		LVL1 V2	NEPD0	48H	PBS0		LVL2_WW2	
09H	TBHP		LVL1 V	NEPD1	49H	PBS1		PHS2_WW	
0AH	STATUS		LVL2 V1	NEPD2	4AH	PCS0		LVL3_WW1	
0BH	PBP		LVL2 V2	NEPD3	4BH			LVL3_WW2	
0CH	IAR2		PHS2 V	NEPD4	4CH			PHS3_WW	
0DH	MP2L		LVL3 V1	NEPD5	4DH			LVL4_WW1	
0EH	MP2H		LVL3 V2	NEPD6	4EH	STMC0		LVL4_WW2	
0FH	RSTFC		LVL4 V1	NEPD7	4FH	STMC1		PHS4_WW	
10H	INTC0		LVL4 V2	NEPDBG	50H	STMDL			
11H	INTC1		PHS4 V		51H	STMDH			
12H	INTC2		LVL0_KK1		52H	STMAL			
13H	INTC3		LVL0_KK2		53H	STMAH			
14H	PA		PHS0_KK		54H	STM RP			
15H	PAC		LVL1_KK1		55H	CTMOC0			
16H	PAPU		LVL1_KK2		56H	CTMOC1			
17H	PAWU		LVL2_KK1		57H	CTMODL			
18H	PB		LVL2_KK2		58H	CTMODH			
19H	PBC		PHS1_KK		59H	CTMOAL			
1AH	PBPU		LVL1_KW1		5AH	CTMOAH			
1BH	PC		LVL1_KW2		5BH				
1CH	PCC		PHS2_KK		5CH				
1DH	PCPU		LVL3_KK1		5DH	CTM1C0			
1EH			LVL3_KK2		5EH	CTM1C1			
1FH			PHS3_KK		5FH	CTM1DL			
20H			LVL4_KK1		60H	CTM1DH			
21H	PSC0R		LVL4_KK2		61H	CTM1AL			
22H	PSC1R		PHS4_KK		62H	CTM1AH			
23H			LVL0_KW1		63H				
24H			LVL0_KW2		64H	TB0C			
25H			PHS0_KW		65H	TB1C			
26H			LVL1_KW1		66H				
27H			LVL1_KW2		67H	SIMC0			
28H			PHS1_KW		68H	SIMC1/UUCR1			
29H	SADOL		LVL2_KW1		69H	SIMC2/SIMA/UUCR2			
2AH	SAD0H		LVL2_KW2		6AH	SIMD/UTXR_RXR			
2BH	SADC0		PHS2_KW		6BH	SIMTOC/UBRG			
2CH	SADC1		LVL3_KW1		6CH	UUSR			
2DH	SADC2		LVL3_KW2		6DH	SPIAC0			
2EH	RSTC		PHS3_KW		6EH	SPIAC1			
2FH	PMPS		LVL4_KW1		6FH	SPIAD			
30H	LVPUC		LVL4_KW2		70H				
31H			PHS4_KW		71H				
32H			LVL0_WK1		72H				
33H	MF10		LVL0_WK2		73H				
34H	MF11		PHS0_WK		74H	FARL			
35H	MF12		LVL1_WK1		75H	FARH			
36H			LVL1_WK2		76H	FD0L			
37H			PHS1_WK		77H	FD0H			
38H			LVL2_WK1		78H	FD1L			
39H	INTEG		LVL2_WK2		79H	FD1H			
3AH	SCC		PHS2_WK		7AH	FD2L			
3BH	HIRCC		LVL3_WK1		7BH	FD2H			
3CH			LVL3_WK2		7CH	FD3L			
3DH	LXTC		PHS3_WK		7DH	FD3H			
3EH	WDTC		LVL4_WK1		7EH				
3FH	LVRC		LVL4_WK2		7FH				

☐ : Unused, read as 00H

Special Purpose Data Memory

Special Function Register Description

Most of the Special Function Register details will be described in the relevant functional sections, however several registers require a separate description in this section.

Indirect Addressing Registers – IAR0, IAR1, IAR2

The Indirect Addressing Registers, IAR0, IAR1 and IAR2, although having their locations in normal RAM register space, do not actually physically exist as normal registers. The method of indirect addressing for RAM data manipulation uses these Indirect Addressing Registers and Memory Pointers, in contrast to direct memory addressing, where the actual memory address is specified. Actions on the IAR0, IAR1 and IAR2 registers will result in no actual read or write operation to these registers but rather to the memory location specified by their corresponding Memory Pointers, MP0, MP1L/MP1H or MP2L/MP2H. Acting as a pair, IAR0 and MP0 can together access data only from Sector 0 while the IAR1 register together with the MP1L/MP1H register pair and IAR2 register together with the MP2L/MP2H register pair can access data from any Data Memory Sector. As the Indirect Addressing Registers are not physically implemented, reading the Indirect Addressing Registers will return a result of “00H” and writing to the registers will result in no operation.

Memory Pointers – MP0, MP1L, MP1H, MP2L, MP2H

Five Memory Pointers, known as MP0, MP1L, MP1H, MP2L, MP2H, are provided. These Memory Pointers are physically implemented in the Data Memory and can be manipulated in the same way as normal registers providing a convenient way with which to address and track data. When any operation to the relevant Indirect Addressing Registers is carried out, the actual address that the microcontroller is directed to is the address specified by the related Memory Pointer. MP0, together with Indirect Addressing Register, IAR0, are used to access data from Sector 0, while MP1L/MP1H together with IAR1 and MP2L/MP2H together with IAR2 are used to access data from all sectors according to the corresponding MP1H or MP2H register. Direct Addressing can be used in all sectors using the corresponding instruction which can address all available data memory space.

The following example shows how to clear a section of four Data Memory locations already defined as locations `adres1` to `adres4`.

Indirect Addressing Program Example 1

```
data .section 'data'
adres1 db ?
adres2 db ?
adres3 db ?
adres4 db ?
block db ?
code .section at 0 'code'
org 00h
start:
    mov a, 04h                ; setup size of block
    mov block, a
    mov a, offset adres1     ; Accumulator loaded with first RAM address
    mov mp0, a               ; setup memory pointer with first RAM address
loop:
    clr IAR0                 ; clear the data at address defined by MP0
    inc mp0                  ; increment memory pointer
    sdz block                ; check if last memory location has been cleared
    jmp loop
continue:
```

Indirect Addressing Program Example 2

```

data .section 'data'
adres1 db ?
adres2 db ?
adres3 db ?
adres4 db ?
block db ?
code .section at 0 'code'
org 00h
start:
    mov a, 04h                ; setup size of block
    mov block, a
    mov a, 01h                ; setup the memory sector
    mov mplh, a
    mov a, offset adres1     ; Accumulator loaded with first RAM address
    mov mp1l, a              ; setup memory pointer with first RAM address
loop:
    clr IAR1                 ; clear the data at address defined by MP1L
    inc mp1l                 ; increment memory pointer MP1L
    sdz block                 ; check if last memory location has been cleared
    jmp loop
continue:

```

The important point to note here is that in the example shown above, no reference is made to specific Data Memory addresses.

Direct Addressing Program Example using extended instructions

```

data .section 'data'
temp db ?
code .section at 0 'code'
org 00h
start:
    lmov a, [m]              ; move [m] data to acc
    lsub a, [m+1]            ; compare [m] and [m+1] data
    snz c                    ; [m]>[m+1]?
    jmp continue            ; no
    lmov a, [m]              ; yes, exchange [m] and [m+1] data
    mov temp, a
    lmov a, [m+1]
    lmov [m], a
    mov a, temp
    lmov [m+1], a
continue:

```

Note: Here “m” is a data memory address located in any data memory sectors. For example, m=1F0H, it indicates address 0F0H in Sector 1.

Program Memory Bank Pointer – PBP

For the device the Program Memory is divided into several banks. Selecting the required Program Memory area is achieved using the Program Memory Bank Pointer, PBP. The PBP register should be properly configured before the device executes the “Branch” operation using the “JMP” or “CALL” instruction. After that a jump to a non-consecutive Program Memory address which is located in a certain bank selected by the program memory bank pointer bits will occur.

• **PBP Register**

Bit	7	6	5	4	3	2	1	0
Name	—	—	—	—	—	—	—	PBP0
R/W	—	—	—	—	—	—	—	R/W
POR	—	—	—	—	—	—	—	0

Bit 7~1 Unimplemented, read as “0”
 Bit 0 **PBP0**: Program Memory Bank Point bit
 0: Bank 0
 1: Bank 1

Accumulator – ACC

The Accumulator is central to the operation of any microcontroller and is closely related with operations carried out by the ALU. The Accumulator is the place where all intermediate results from the ALU are stored. Without the Accumulator it would be necessary to write the result of each calculation or logical operation such as addition, subtraction, shift, etc., to the Data Memory resulting in higher programming and timing overheads. Data transfer operations usually involve the temporary storage function of the Accumulator; for example, when transferring data between one user-defined register and another, it is necessary to do this by passing the data through the Accumulator as no direct transfer between two registers is permitted.

Program Counter Low Register – PCL

To provide additional program control functions, the low byte of the Program Counter is made accessible to programmers by locating it within the Special Purpose area of the Data Memory. By manipulating this register, direct jumps to other program locations are easily implemented. Loading a value directly into this PCL register will cause a jump to the specified Program Memory location, however, as the register is only 8-bit wide, only jumps within the current Program Memory page are permitted. When such operations are used, note that a dummy cycle will be inserted.

Look-up Table Registers – TBLP, TBHP, TBLH

These three special function registers are used to control operation of the look-up table which is stored in the Program Memory. TBLP and TBHP are the table pointers and indicate the location where the table data is located. Their value must be setup before any table read commands are executed. Their value can be changed, for example using the “INC” or “DEC” instructions, allowing for easy table data pointing and reading. TBLH is the location where the high order byte of the table data is stored after a table read data instruction has been executed. Note that the lower order table data byte is transferred to a user defined location.

Status Register – STATUS

This 8-bit register contains the SC flag, CZ flag, zero flag (Z), carry flag (C), auxiliary carry flag (AC), overflow flag (OV), power down flag (PDF), and watchdog time-out flag (TO). These arithmetic/logical operation and system management flags are used to record the status and operation of the microcontroller.

With the exception of the TO and PDF flags, bits in the status register can be altered by instructions like most other registers. Any data written into the status register will not change the TO or PDF flag. In addition, operations related to the status register may give different results due to the different instruction operations. The TO flag can be affected only by a system power-up, a WDT time-out or by executing the “CLR WDT” or “HALT” instruction. The PDF flag is affected only by executing the “HALT” or “CLR WDT” instruction or during a system power-up.

The Z, OV, AC, C, SC and CZ flags generally reflect the status of the latest operations.

- C is set if an operation results in a carry during an addition operation or if a borrow does not take place during a subtraction operation; otherwise C is cleared. C is also affected by a rotate through carry instruction.
- AC is set if an operation results in a carry out of the low nibbles in addition, or no borrow from the high nibble into the low nibble in subtraction; otherwise AC is cleared.
- Z is set if the result of an arithmetic or logical operation is zero; otherwise Z is cleared.
- OV is set if an operation results in a carry into the highest-order bit but not a carry out of the highest-order bit, or vice versa; otherwise OV is cleared.
- PDF is cleared by a system power-up or executing the “CLR WDT” instruction. PDF is set by executing the “HALT” instruction.
- TO is cleared by a system power-up or executing the “CLR WDT” or “HALT” instruction. TO is set by a WDT time-out.
- CZ is the operational result of different flags for different instructions. Refer to register definitions for more details.
- SC is the result of the “XOR” operation which is performed by the OV flag and the MSB of the current instruction operation result.

In addition, on entering an interrupt sequence or executing a subroutine call, the status register will not be pushed onto the stack automatically. If the contents of the status registers are important and if the subroutine can corrupt the status register, precautions must be taken to correctly save it.

• **STATUS Register**

Bit	7	6	5	4	3	2	1	0
Name	SC	CZ	TO	PDF	OV	Z	AC	C
R/W	R/W	R/W	R	R	R/W	R/W	R/W	R/W
POR	x	x	0	0	x	x	x	x

“x”: unknown

- Bit 7 **SC**: The result of the “XOR” operation which is performed by the OV flag and the MSB of the instruction operation result.
- Bit 6 **CZ**: The operational result of different flags for different instructions.
For SUB/SUBM/LSUB/LSUBM instructions, the CZ flag is equal to the Z flag.
For SBC/SBCM/LSBC/LSBCM instructions, the CZ flag is the “AND” operation result which is performed by the previous operation CZ flag and current operation zero flag.
For other instructions, the CZ flag will not be affected.
- Bit 5 **TO**: Watchdog Time-Out Flag
0: After power up or executing the “CLR WDT” or “HALT” instruction
1: A watchdog time-out occurred.
- Bit 4 **PDF**: Power Down Flag
0: After power up or executing the “CLR WDT” instruction
1: By executing the “HALT” instruction
- Bit 3 **OV**: Overflow Flag
0: No overflow
1: An operation results in a carry into the highest-order bit but not a carry out of the highest-order bit or vice versa.
- Bit 2 **Z**: Zero Flag
0: The result of an arithmetic or logical operation is not zero
1: The result of an arithmetic or logical operation is zero

- Bit 1 **AC:** Auxiliary flag
 0: No auxiliary carry
 1: An operation results in a carry out of the low nibbles in addition, or no borrow from the high nibble into the low nibble in subtraction
- Bit 0 **C:** Carry Flag
 0: No carry-out
 1: An operation results in a carry during an addition operation or if a borrow does not take place during a subtraction operation
- The “C” flag is also affected by a rotate through carry instruction.

EEPROM Data Memory

This device contains an area of internal EEPROM Data Memory. EEPROM is by its nature a non-volatile form of re-programmable memory, with data retention even when its power supply is removed. By incorporating this kind of data memory, a whole new host of application possibilities are made available to the designer. The availability of EEPROM storage allows information such as product identification numbers, calibration values, specific user data, system setup data or other product information to be stored directly within the product microcontroller. The process of reading and writing data to the EEPROM memory has been reduced to a very trivial affair.

EEPROM Data Memory Structure

The EEPROM Data Memory capacity is 128×8 bits for the device. Unlike the Program Memory and RAM Data Memory, the EEPROM Data Memory is not directly mapped into memory space and is therefore not directly addressable in the same way as the other types of memory. Read and Write operations to the EEPROM are carried out in single byte operations using an address and a data register in Sector 0 and a single control register in Sector 1.

EEPROM Registers

Three registers control the overall operation of the internal EEPROM Data Memory. These are the address register, EEA, the data register, EED and a single control register, EEC. As both the EEA and EED registers are located in Sector 0, they can be directly accessed in the same way as any other Special Function Register. The EEC register however, being located in Sector 1, can only be read from or written to indirectly using the MP1L/MP1H or MP2L/MP2H Memory Pointer and Indirect Addressing Register, IAR1/IAR2. Because the EEC control register is located at address 40H in Sector 1, the MP1L or MP2L Memory Pointer must first be set to the value 40H and the MP1H or MP2H Memory Pointer high byte set to the value, 01H, before any operations on the EEC register are executed.

Register Name	Bit							
	7	6	5	4	3	2	1	0
EEA	—	EEA6	EEA5	EEA4	EEA3	EEA2	EEA1	EEA0
EED	EED7	EED6	EED5	EED4	EED3	EED2	EED1	EED0
EEC	—	—	—	—	WREN	WR	RDEN	RD

EEPROM Register List

• **EEA Register**

Bit	7	6	5	4	3	2	1	0
Name	—	EEA6	EEA5	EEA4	EEA3	EEA2	EEA1	EEA0
R/W	—	R/W	R/W	R/W	R/W	R/W	R/W	R/W
POR	—	0	0	0	0	0	0	0

Bit 7 Unimplemented, read as “0”

Bit 6~0 **EEA6~EEA0**: Data EEPROM address bit 6~bit 0

• **EED Register**

Bit	7	6	5	4	3	2	1	0
Name	EED7	EED6	EED5	EED4	EED3	EED2	EED1	EED0
R/W	R/W	R/W	R/W	R/W	R/W	R/W	R/W	R/W
POR	0	0	0	0	0	0	0	0

Bit 7~0 **EED7~EED0**: Data EEPROM data bit 7~bit 0

• **EEC Register**

Bit	7	6	5	4	3	2	1	0
Name	—	—	—	—	WREN	WR	RDEN	RD
R/W	—	—	—	—	R/W	R/W	R/W	R/W
POR	—	—	—	—	0	0	0	0

Bit 7~4 Unimplemented, read as “0”

Bit 3 **WREN**: Data EEPROM Write Enable
0: Disable
1: Enable

This is the Data EEPROM Write Enable Bit which must be set high before Data EEPROM write operations are carried out. Clearing this bit to zero will inhibit Data EEPROM write operations.

Bit 2 **WR**: EEPROM Write Control
0: Write cycle has finished
1: Activate a write cycle

This is the Data EEPROM Write Control Bit and when set high by the application program will activate a write cycle. This bit will be automatically reset to zero by the hardware after the write cycle has finished. Setting this bit high will have no effect if the WREN has not first been set high.

Bit 1 **RDEN**: Data EEPROM Read Enable
0: Disable
1: Enable

This is the Data EEPROM Read Enable Bit which must be set high before Data EEPROM read operations are carried out. Clearing this bit to zero will inhibit Data EEPROM read operations.

Bit 0 **RD**: EEPROM Read Control
0: Read cycle has finished
1: Activate a read cycle

This is the Data EEPROM Read Control Bit and when set high by the application program will activate a read cycle. This bit will be automatically reset to zero by the hardware after the read cycle has finished. Setting this bit high will have no effect if the RDEN bit has not first been set high.

Note: 1. The WREN, WR, RDEN and RD cannot be set high at the same time in one instruction. The WR and RD cannot be set high at the same time.

2. Ensure that the f_{SUB} clock is stable before executing the write operation.

3. Ensure that the write operation is totally complete before changing the EEC register content.

Reading Data from the EEPROM

To read data from the EEPROM, the EEPROM address of the data to be read must first be placed in the EEA register. Then the read enable bit, RDEN, in the EEC register must be set high to enable the read function. If the RD bit in the EEC register is now set high, a read cycle will be initiated. Setting the RD bit high will not initiate a read operation if the RDEN bit has not been set. When the read cycle terminates, the RD bit will be automatically cleared to zero, after which the data can be read from the EED register. The data will remain in the EED register until another read or write operation is executed. The application program can poll the RD bit to determine when the data is valid for reading.

Writing Data to the EEPROM

To write data to the EEPROM, the EEPROM address of the data to be written must first be placed in the EEA register and the data placed in the EED register. To initiate a write cycle, the write enable bit, WREN, in the EEC register must first be set high to enable the write function. After this, the WR bit in the EEC register must be immediately set high to initiate a write cycle. These two instructions must be executed in two consecutive instruction cycles. The global interrupt bit EMI should also first be cleared before implementing any write operations, and then set again after the write cycle has started. Note that setting the WR bit high will not initiate a write cycle if the WREN bit has not been set. As the EEPROM write cycle is controlled using an internal timer whose operation is asynchronous to microcontroller system clock, a certain time will elapse before the data will have been written into the EEPROM. Detecting when the write cycle has finished can be implemented either by polling the WR bit in the EEC register or by using the EEPROM interrupt. When the write cycle terminates, the WR bit will be automatically cleared to zero by the microcontroller, informing the user that the data has been written to the EEPROM. The application program can therefore poll the WR bit to determine when the write cycle has ended.

Write Protection

Protection against inadvertent write operation is provided in several ways. After the device is powered-on the Write Enable bit in the control register will be cleared preventing any write operations. Also at power-on the Memory Pointer high byte register, MP1H or MP2H, will be reset to zero, which means that Data Memory Sector 0 will be selected. As the EEPROM control register is located in Sector 1, this adds a further measure of protection against spurious write operations. During normal program operation, ensuring that the Write Enable bit in the control register is cleared will safeguard against incorrect write operations.

EEPROM Interrupt

The EEPROM write interrupt is generated when an EEPROM write cycle has ended. The EEPROM interrupt must first be enabled by setting the DEE bit in the relevant interrupt register. However as the EEPROM is contained within a Multi-function Interrupt, the associated multi-function interrupt enable bit must also be set. When an EEPROM write cycle ends, the DEF request flag and its associated multi-function interrupt request flag will both be set. If the global, EEPROM and Multi-function interrupts are enabled and the stack is not full, a jump to the associated Multi-function Interrupt vector will take place. When the interrupt is serviced only the Multi-function interrupt flag will be automatically reset, the EEPROM interrupt flag must be manually reset by the application program. More details can be obtained in the Interrupt section.

Programming Considerations

Care must be taken that data is not inadvertently written to the EEPROM. Protection can be enhanced by ensuring that the Write Enable bit is normally cleared to zero when not writing. Also the Memory Pointer high byte register, MP1H or MP2H, could be normally cleared to zero as this would inhibit access to Sector 1 where the EEPROM control register exist. Although certainly not necessary, consideration might be given in the application program to the checking of the validity of new write data by a simple read back process.

When writing data the WR bit must be set high immediately after the WREN bit has been set high, to ensure the write cycle executes correctly. The global interrupt bit EMI should also be cleared before a write cycle is executed and then re-enabled after the write cycle starts. Note that the device should not enter the IDLE or SLEEP mode until the EEPROM read or write operation is totally complete. Otherwise, the EEPROM read or write operation will fail.

Programming Examples

Reading data from the EEPROM – polling method

```

MOV A, EEPROM_ADRES      ; user defined address
MOV EEA, A
MOV A, 40H                ; setup memory pointer low byte MP1L
MOV MP1L, A              ; MP1L points to EEC register
MOV A, 01H               ; setup memory pointer high byte MP1H
MOV MP1H, A
SET IAR1.1               ; set RDEN bit, enable read operations
SET IAR1.0               ; start Read Cycle - set RD bit
BACK:
SZ IAR1.0                ; check for read cycle end
JMP BACK
CLR IAR1                  ; disable EEPROM read if no more read operations are required
CLR MP1H
MOV A, EED                ; move read data to register
MOV READ_DATA, A

```

Note: For each read operation, the address register should be re-specified followed by setting the RD bit high to activate a read cycle even if the target address is consecutive.

Writing Data to the EEPROM – polling method

```

MOV A, EEPROM_ADRES      ; user defined address
MOV EEA, A
MOV A, EEPROM_DATA       ; user defined data
MOV EED, A
MOV A, 040H              ; setup memory pointer low byte MP1L
MOV MP1L, A              ; MP1L points to EEC register
MOV A, 01H               ; setup memory pointer high byte MP1H
MOV MP1H, A
CLR EMI
SET IAR1.3               ; set WREN bit, enable write operations
SET IAR1.2               ; start Write Cycle - set WR bit - executed immediately
                        ; after set WREN bit

SET EMI
BACK:
SZ IAR1.2                ; check for write cycle end
JMP BACK
CLR MP1H

```

Oscillators

Various oscillator options offer the user a wide range of functions according to their various application requirements. The flexible features of the oscillator functions ensure that the best optimisation can be achieved in terms of speed and power saving. Oscillator selections and operation are selected through a combination of configuration options and relevant control registers.

Oscillator Overview

In addition to being the source of the main system clock the oscillators also provide clock sources for the Watchdog Timer and Time Base Interrupts. External oscillators requiring some external components as well as fully integrated internal oscillators, requiring no external components, are provided to form a wide range of both fast and slow system oscillators. All oscillator options are selected through the registers. The higher frequency oscillators provide higher performance but carry with it the disadvantage of higher power requirements, while the opposite is of course true for the lower frequency oscillators. With the capability of dynamically switching between fast and slow system clock, the device have the flexibility to optimize the performance/power ratio, a feature especially important in power sensitive portable applications.

Type	Name	Freq.	Pins
Internal High Speed RC	HIRC	4/8/12MHz	—
External Low Speed Crystal	LXT	32.768kHz	XT1/XT2
Internal Low Speed RC	LIRC	32kHz	—

Oscillator Types

System Clock Configurations

There are two methods of generating the system clock, a high speed oscillator and a low speed oscillator. The high speed oscillator is the internal 4/8/12MHz RC oscillator, HIRC. The low speed oscillator is the external 32.768kHz crystal oscillator, LXT. Selecting whether the low or high speed oscillator is used as the system oscillator is implemented using the CKS2~CKS0 bits in the SCC register and as the system clock can be dynamically selected.

The actual source clock used for the low speed oscillators is chosen via registers. The frequency of the slow speed or high speed system clock is determined using the CKS2~CKS0 bits in the SCC register. Note that two oscillator selections must be made namely one high speed and one low speed system oscillators.

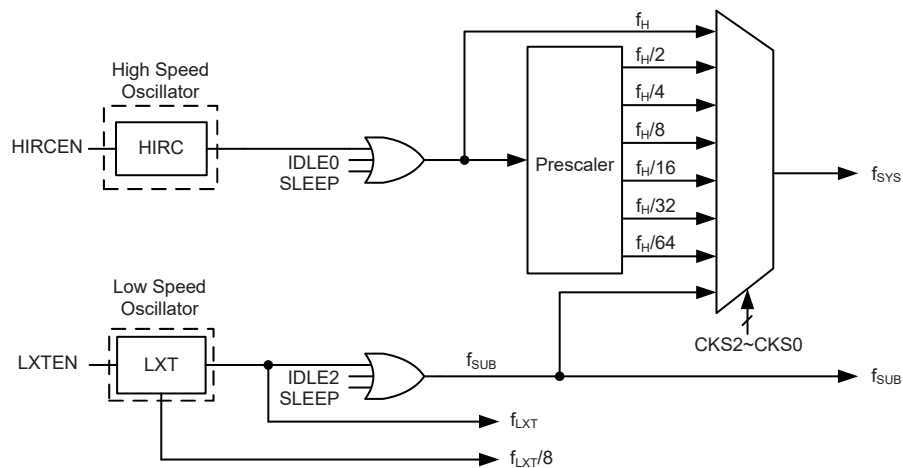

System Clock Configurations

Internal RC Oscillator – HIRC

The internal RC oscillator is a fully integrated system oscillator requiring no external components. The internal RC oscillator has three fixed frequencies of 4MHz, 8MHz and 12MHz, which is selected using a configuration option. The HIRC1~HIRC0 bits in the HIRCC register must also be setup to match the selected configuration option frequency. Setting up these bits is necessary to ensure that the HIRC frequency accuracy specified in the A.C. Characteristics is achieved. Device trimming during the manufacturing process and the inclusion of internal frequency compensation circuits are used to ensure that the influence of the power supply voltage, temperature and process variations on the oscillation frequency are minimised.

External 32.768 kHz Crystal Oscillator – LXT

The External 32.768kHz Crystal System Oscillator is the low frequency oscillator choice, which is always enabled. This clock source has a frequency of 32.768kHz and requires a 32.768kHz crystal to be connected between pins XT1 and XT2. In addition of supplying f_{LXT} with the frequency of 32.768kHz, the clock source also provides a divided version of $f_{LXT}/8$ for the Watchdog Timer and Time Base functions. The external capacitor components connected to the 32.768kHz crystal are necessary to provide oscillation. For applications where precise frequencies are essential, these components may be required to provide frequency compensation due to different crystal manufacturing tolerances. After the LXT oscillator is enabled, there is a time delay associated with the LXT oscillator waiting for it to start-up.

However, for some crystals, to ensure oscillation and accurate frequency generation, it is necessary to add two small value external capacitors, C1 and C2. The exact values of C1 and C2 should be selected in consultation with the crystal or resonator manufacturer's specification.

For oscillator stability and to minimise the effects of noise and crosstalk, it is important to ensure that the crystal and any associated capacitors along with interconnecting lines are all located as close to the MCU as possible.

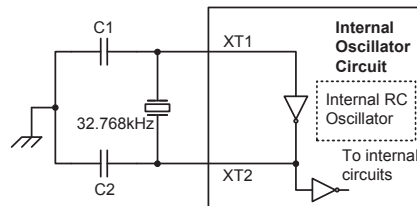

- Note:
1. C1 and C2 are required.
 2. Although not shown pins have a parasitic capacitance of around 7pF.
 3. Although not shown the oscillator circuit has two output frequency of f_{LXT} and $f_{LXT}/8$.

External LXT Oscillator

LXT Oscillator C1 and C2 Values		
Crystal Frequency	C1	C2
32.768kHz	7pF	7pF
Note: C1 and C2 values are for guidance only.		

32.768kHz Crystal Recommended Capacitor Values

Internal 32kHz Oscillator – LIRC

The Internal 32kHz Oscillator is a fully integrated RC oscillator with a typical frequency of 32kHz at 5V, requiring no external components for its implementation. Note that the internal 32kHz oscillator is only used as clock source for power on reset, low voltage reset and low voltage detector functions. Device trimming during the manufacturing process and the inclusion of internal frequency compensation circuits are used to ensure that the influence of the power supply voltage, temperature and process variations on the oscillation frequency are minimised.

Operating Modes and System Clocks

Present day applications require that their microcontrollers have high performance but often still demand that they consume as little power as possible, conflicting requirements that are especially true in battery powered portable applications. The fast clocks required for high performance will by their nature increase current consumption and of course vice versa, lower speed clocks reduce current consumption. As both high and low speed clock sources are provided the means to switch between them dynamically, the user can optimise the operation of their microcontroller to achieve the best performance/power ratio.

System Clocks

The device has different clock sources for both the CPU and peripheral function operation. By providing the user with a wide range of clock selections using configuration options and register programming, a clock system can be configured to obtain maximum application performance.

The main system clock, can come from either a high frequency, f_H , or low frequency, f_{SUB} , source, and is selected using the CKS2~CKS0 bits in the SCC register. The high speed system clock is sourced from the HIRC oscillator. The low speed system clock source can be sourced from the internal clock f_{SUB} . If f_{SUB} is selected then it can be sourced from the LXT oscillator. The other choice, which is a divided version of the high speed system oscillator has a range of $f_H/2 \sim f_H/64$. Note that the LIRC oscillator is only used for power on, low voltage detector and low voltage reset functions. The LXT oscillator is always on even when the device enters the SLEEP mode and the WDT function is disabled.

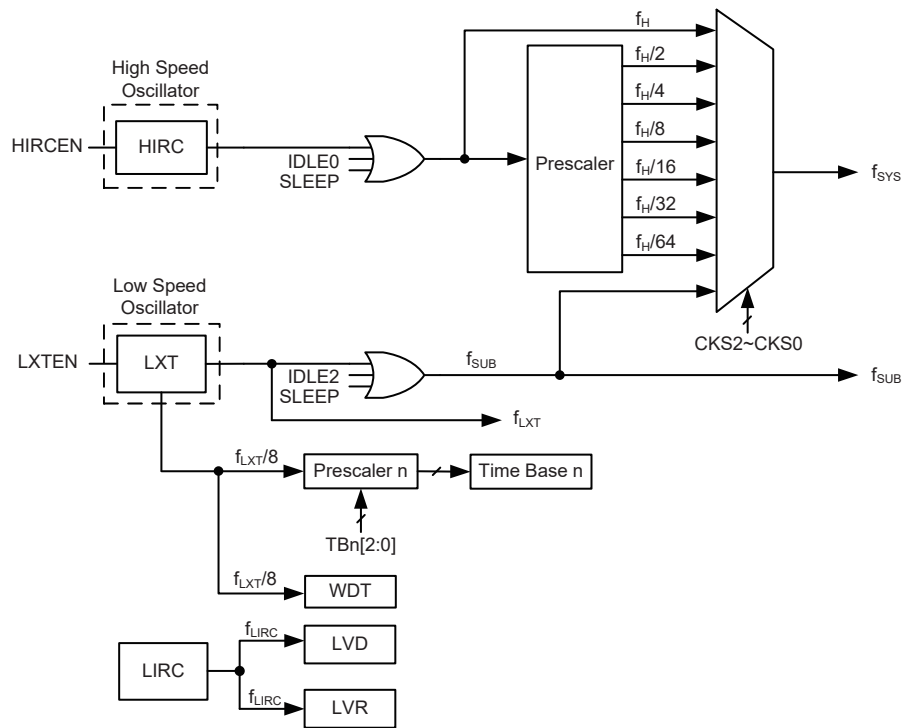

Device Clock Configurations

Note: When the system clock source f_{SYS} is switched to f_{SUB} from f_H , the high speed oscillator can be stopped to conserve the power or continue to oscillate to provide the clock source, $f_H \sim f_H/64$, for peripheral circuit to use, which is determined by configuring the corresponding high speed oscillator enable control bit.

System Operation Modes

There are six different modes of operation for the microcontroller, each one with its own special characteristics and which can be chosen according to the specific performance and power requirements of the application. There are two modes allowing normal operation of the microcontroller, the FAST Mode and SLOW Mode. The remaining four modes, the SLEEP, IDLE0, IDLE1 and IDLE2 Mode are used when the microcontroller CPU is switched off to conserve power.

Operation Mode	CPU	Register Setting			f _{sys}	f _H	f _{SUB}	f _{LXT}
		FHIDEN	FSIDEN	CKS2~CKS0				
FAST	On	x	x	000~110	f _H ~f _H /64	On	On	On
SLOW	On	x	x	111	f _{SUB}	On/Off ^(Note)	On	On
IDLE0	Off	0	1	000~110	Off	Off	On	On
				111	On			
IDLE1	Off	1	1	xxx	On	On	On	On
IDLE2	Off	1	0	000~110	On	On	Off	On
				111	Off			
SLEEP	Off	0	0	xxx	Off	Off	Off	On

“x”: don't care

Note: The f_H clock will be switched on or off by configuring the corresponding oscillator enable bit in the SLOW mode.

FAST Mode

This is one of the main operating modes where the microcontroller has all of its functions operational and where the system clock is provided by the high speed oscillator. This mode operates allowing the microcontroller to operate normally with a clock source will come from the HIRC oscillator. The high speed oscillator will however first be divided by a ratio ranging from 1 to 64, the actual ratio being selected by the CKS2~CKS0 bits in the SCC register. Although a high speed oscillator is used, running the microcontroller at a divided clock ratio reduces the operating current.

SLOW Mode

This is also a mode where the microcontroller operates normally although now with a slower speed clock source. The clock source used will be from f_{SUB}. The f_{SUB} clock is derived from the LXT oscillator.

SLEEP Mode

The SLEEP Mode is entered when an HALT instruction is executed and when the FHIDEN and FSIDEN bit are low. In the SLEEP mode the CPU will be stopped, and the f_{SUB} clock to peripheral will be stopped too. However if the WDT function is enabled or disabled is determined by the WDTC register.

IDLE0 Mode

The IDLE0 Mode is entered when a HALT instruction is executed and when the FHIDEN bit in the SCC register is low and the FSIDEN bit in the SCC register is high. In the IDLE0 Mode the CPU will be switched off but the low speed oscillator will be turned on to drive some peripheral functions.

IDLE1 Mode

The IDLE1 Mode is entered when an HALT instruction is executed and when the FHIDEN bit in the SCC register is high and the FSIDEN bit in the SCC register is high. In the IDLE1 Mode the CPU will be switched off but both the high and low speed oscillators will be turned on to provide a clock source to keep some peripheral functions operational.

IDLE2 Mode

The IDLE2 Mode is entered when an HALT instruction is executed and when the FHIDEN bit in the SCC register is high and the FSIDEN bit in the SCC register is low. In the IDLE2 Mode the CPU will be switched off but the high speed oscillator will be turned on to provide a clock source to keep some peripheral functions operational.

Control Registers

The registers, SCC, HIRCC and LXTC, are used to control the system clock and the corresponding oscillator configurations.

Register Name	Bit							
	7	6	5	4	3	2	1	0
SCC	CKS2	CKS1	CKS0	—	—	—	FHIDEN	FSIDEN
HIRCC	—	—	—	—	HIRC1	HIRC0	HIRCF	HIRCEN
LXTC	—	—	—	—	—	—	LXTF	LXTEN

System Operating Mode Control Register List

• **SCC Register**

Bit	7	6	5	4	3	2	1	0
Name	CKS2	CKS1	CKS0	—	—	—	FHIDEN	FSIDEN
R/W	R/W	R/W	R/W	—	—	—	R/W	R/W
POR	0	0	1	—	—	—	0	0

Bit 7~5 **CKS2~CKS0**: System clock selection

- 000: f_H
- 001: $f_H/2$
- 010: $f_H/4$
- 011: $f_H/8$
- 100: $f_H/16$
- 101: $f_H/32$
- 110: $f_H/64$
- 111: f_{SUB}

These three bits are used to select which clock is used as the system clock source. In addition to the system clock source directly derived from f_H or f_{SUB} , a divided version of the high speed system oscillator can also be chosen as the system clock source.

Bit 4~2 Unimplemented, read as “0”

Bit 1 **FHIDEN**: High Frequency oscillator control when CPU is switched off

- 0: Disable
- 1: Enable

This bit is used to control whether the high speed oscillator is activated or stopped when the CPU is switched off by executing an “HALT” instruction.

Bit 0 **FSIDEN**: Low Frequency oscillator control when CPU is switched off

- 0: Disable
- 1: Enable

This bit is used to control whether the low speed oscillator is activated or stopped when the CPU is switched off by executing an “HALT” instruction.

• **HIRCC Register**

Bit	7	6	5	4	3	2	1	0
Name	—	—	—	—	HIRC1	HIRC0	HIRCF	HIRCEN
R/W	—	—	—	—	R/W	R/W	R	R/W
POR	—	—	—	—	0	0	0	1

Bit 7~4 Unimplemented, read as “0”

Bit 3~2 **HIRC1~HIRC0**: HIRC Frequency selection

00: 4MHz
01: 8MHz
10: 12MHz
11: 4MHz

When the HIRC oscillator is enabled or the HIRC frequency selection is changed by application program, the clock frequency will automatically be changed after the HIRCF flag is set high.

It is recommended that the HIRC frequency selected by these two bits should be the same with the frequency determined by the configuration option to achieve the HIRC frequency accuracy specified in the A.C. Characteristics.

Bit 1 **HIRCF**: HIRC oscillator stable flag

0: HIRC unstable
1: HIRC stable

This bit is used to indicate whether the HIRC oscillator is stable or not. When the HIRCEN bit is set to 1 to enable the HIRC oscillator or the HIRC frequency selection is changed by application program, the HIRCF bit will first be cleared to 0 and then set to 1 after the HIRC oscillator is stable.

Bit 0 **HIRCEN**: HIRC oscillator enable control

0: Disable
1: Enable

• **LXTC Register**

Bit	7	6	5	4	3	2	1	0
Name	—	—	—	—	—	—	LXTF	LXTEN
R/W	—	—	—	—	—	—	R	R
POR	—	—	—	—	—	—	0	1

Bit 7~2 Unimplemented, read as 0

Bit 1 **LXTF**: LXT oscillator stable flag

0: LXT unstable
1: LXT stable

This bit is used to indicate whether the LXT oscillator is stable or not. When the LXT oscillator is enabled, the LXTF bit will first be cleared to 0 and then set to 1 after the LXT oscillator is stable.

Bit 0 **LXTEN**: LXT oscillator enable control (Read only)

1: Enable

Operating Mode Switching

The device can switch between operating modes dynamically allowing the user to select the best performance/power ratio for the present task in hand. In this way microcontroller operations that do not require high performance can be executed using slower clocks thus requiring less operating current and prolonging battery life in portable applications.

In simple terms, Mode Switching between the FAST Mode and SLOW Mode is executed using the CKS2~CKS0 bits in the SCC register while Mode Switching from the FAST/SLOW Modes to the SLEEP/IDLE Modes is executed via the HALT instruction. When an HALT instruction is executed, whether the device enters the IDLE Mode or the SLEEP Mode is determined by the condition of the FHIDEN and FSIDEN bits in the SCC register.

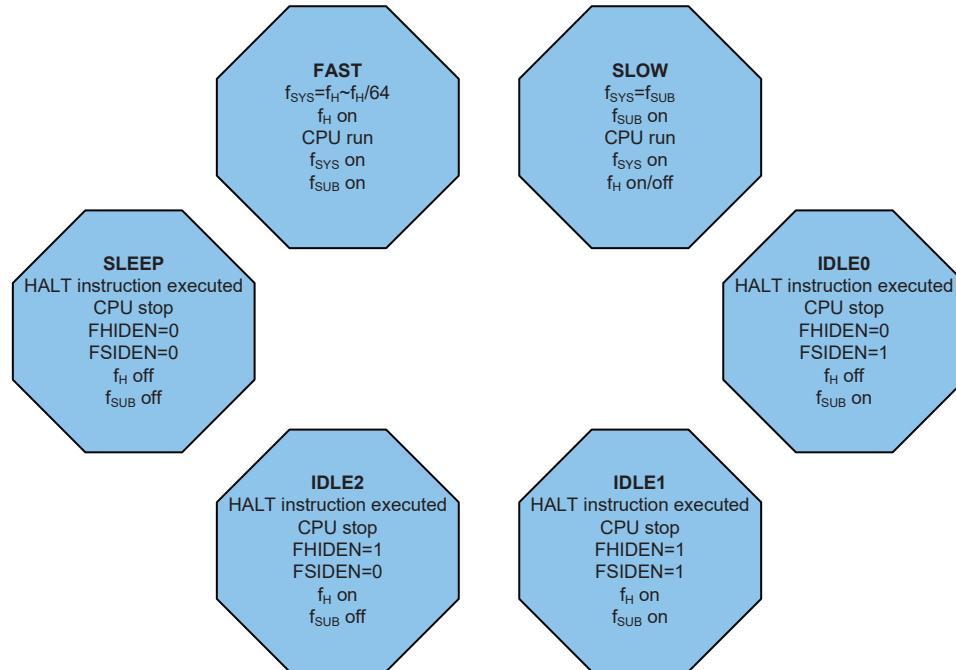

FAST Mode to SLOW Mode Switching

When running in the FAST Mode, which uses the high speed system oscillator, and therefore consumes more power, the system clock can switch to run in the SLOW Mode by set the CKS2~CKS0 bits to “111” in the SCC register. This will then use the low speed system oscillator which will consume less power. Users may decide to do this for certain operations which do not require high performance and can subsequently reduce power consumption.

The SLOW Mode is sourced from the LXT oscillator and therefore requires this oscillator to be stable before full mode switching occurs.

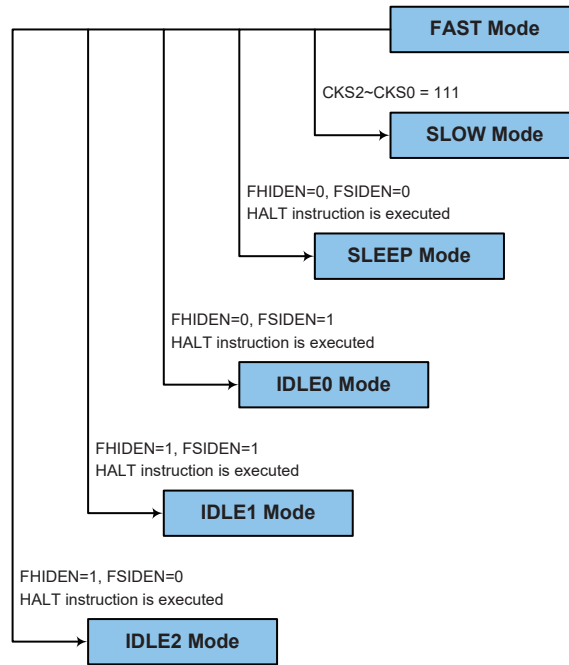

SLOW Mode to FAST Mode Switching

In SLOW mode the system clock is derived from f_{SUB} . When system clock is switched back to the FAST mode from f_{SUB} , the CKS2~CKS0 bits should be set to “000”~“110” and then the system clock will respectively be switched to f_H ~ $f_H/64$.

However, if f_H is not used in SLOW mode and thus switched off, it will take some time to re-oscillate and stabilise when switching to the FAST mode from the SLOW Mode. This is monitored using the HIRCF bit in the HIRCC register. The time duration required for the high speed system oscillator stabilization is specified in the relevant characteristics.

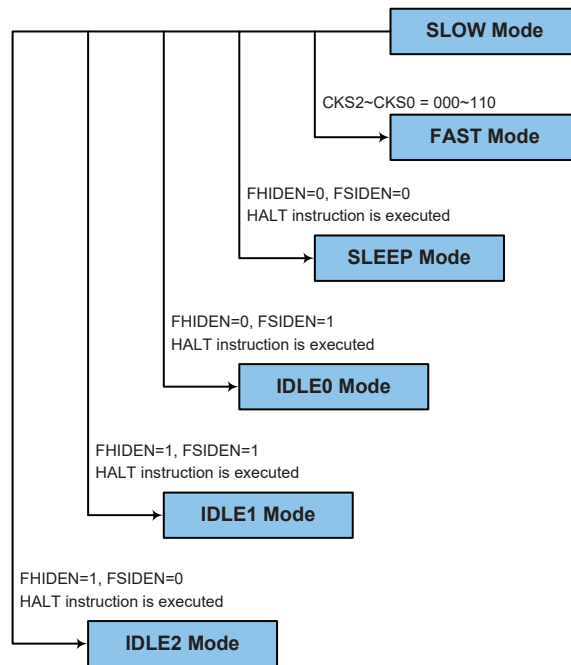

Entering the SLEEP Mode

There is only one way for the device to enter the SLEEP Mode and that is to execute the “HALT” instruction in the application program with both the FHIDEN and FSIDEN bits in the SCC register equal to “0”. In this mode all the clocks and functions will be switched off except the WDT function. When this instruction is executed under the conditions described above, the following will occur:

- The system clock will be stopped and the application program will stop at the “HALT” instruction.
- The Data Memory contents and registers will maintain their present condition.
- The I/O ports will maintain their present conditions.
- In the status register, the Power Down flag PDF will be set, and WDT timeout flag TO will be cleared.
- The WDT will be cleared and resume counting if the WDT function is enabled. If the WDT function is disabled, the WDT will be cleared and then stopped.

Entering the IDLE0 Mode

There is only one way for the device to enter the IDLE0 Mode and that is to execute the “HALT” instruction in the application program with the FHIDEN bit in the SCC register equal to “0” and the FSIDEN bit in the SCC register equal to “1”. When this instruction is executed under the conditions described above, the following will occur:

- The f_H clock will be stopped and the application program will stop at the “HALT” instruction, but the f_{SUB} clock will be on.
- The Data Memory contents and registers will maintain their present condition.
- The I/O ports will maintain their present conditions.
- In the status register, the Power Down flag PDF will be set, and WDT timeout flag TO will be cleared.
- The WDT will be cleared and resume counting if the WDT function is enabled. If the WDT function is disabled, the WDT will be cleared and then stopped.

Entering the IDLE1 Mode

There is only one way for the device to enter the IDLE1 Mode and that is to execute the “HALT” instruction in the application program with both the FHIDEN and FSIDEN bits in the SCC register equal to “1”. When this instruction is executed under the conditions described above, the following will occur:

- The f_H and f_{SUB} clocks will be on but the application program will stop at the “HALT” instruction.
- The Data Memory contents and registers will maintain their present condition.
- The I/O ports will maintain their present conditions.
- In the status register, the Power Down flag PDF will be set, and WDT timeout flag TO will be cleared.
- The WDT will be cleared and resume counting if the WDT function is enabled. If the WDT function is disabled, the WDT will be cleared and then stopped.

Entering the IDLE2 Mode

There is only one way for the device to enter the IDLE2 Mode and that is to execute the “HALT” instruction in the application program with the FHIDEN bit in the SCC register equal to “1” and the FSIDEN bit in the SCC register equal to “0”. When this instruction is executed under the conditions described above, the following will occur:

- The f_H clock will be on but the f_{SUB} clock will be off and the application program will stop at the “HALT” instruction.
- The Data Memory contents and registers will maintain their present condition.
- The I/O ports will maintain their present conditions.
- In the status register, the Power Down flag PDF will be set, and WDT timeout flag TO will be cleared.
- The WDT will be cleared and resume counting if the WDT function is enabled. If the WDT function is disabled, the WDT will be cleared and then stopped.

Standby Current Considerations

As the main reason for entering the SLEEP or IDLE Mode is to keep the current consumption of the device to as low a value as possible, perhaps only in the order of several micro-amps except in the IDLE1 and IDLE2 Mode, there are other considerations which must also be taken into account by the circuit designer if the power consumption is to be minimised. Special attention must be made to the I/O pins on the device. All high-impedance input pins must be connected to either a fixed high or low level as any floating input pins could create internal oscillations and result in increased current consumption. This also applies to devices which have different package types, as there may be unbonded pins. These must either be setup as outputs or if setup as inputs must have pull-high resistors connected.

Care must also be taken with the loads, which are connected to I/O pins, which are setup as outputs. These should be placed in a condition in which minimum current is drawn or connected only to external circuits that do not draw current, such as other CMOS inputs. Also note that additional standby current will also be required if the LXT oscillator has enabled.

In the IDLE1 and IDLE2 Mode the high speed oscillator is on, if the peripheral function clock source is derived from the high speed oscillator, the additional standby current will also be perhaps in the order of several hundred micro-amps.

Wake-up

To minimise power consumption the device can enter the SLEEP or any IDLE Mode, where the CPU will be switched off. However, when the device is woken up again, it will take a considerable time for the original system oscillator to restart, stabilise and allow normal operation to resume.

After the system enters the SLEEP or IDLE Mode, it can be woken up from one of various sources listed as follows:

- An external falling edge on Port A
- An external reset
- A system interrupt
- A WDT overflow

If the system is woken up by an external reset, the device will experience a full system reset, however, if the device is woken up by a WDT overflow, a Watchdog Timer reset will be initiated. Although both of these wake-up methods will initiate a reset operation, the actual source of the wake-up can be determined by examining the TO and PDF flags. The PDF flag is cleared by a system power-up or executing the clear Watchdog Timer instructions and is set when executing the “HALT” instruction. The TO flag is set if a WDT time-out occurs and causes a wake-up that only resets the Program Counter and Stack Pointer, other flags remain in their original status.

Each pin on Port A can be setup using the PAWU register to permit a negative transition on the pin to wake up the system. When a Port A pin wake-up occurs, the program will resume execution at the instruction following the “HALT” instruction. If the system is woken up by an interrupt, then two possible situations may occur. The first is where the related interrupt is disabled or the interrupt is enabled but the stack is full, in which case the program will resume execution at the instruction following the “HALT” instruction. In this situation, the interrupt which woke up the device will not be immediately serviced, but will rather be serviced later when the related interrupt is finally enabled or when a stack level becomes free. The other situation is where the related interrupt is enabled and the stack is not full, in which case the regular interrupt response takes place. If an interrupt request flag is set high before entering the SLEEP or IDLE Mode, the wake-up function of the related interrupt will be disabled.

Watchdog Timer

The Watchdog Timer is provided to prevent program malfunctions or sequences from jumping to unknown locations, due to certain uncontrollable external events such as electrical noise.

Watchdog Timer Clock Source

The Watchdog Timer clock source is provided by the internal clock, f_{WDT} , which is supplied by the LXT oscillator with the output frequency of $f_{LXT}/8$. The Watchdog Timer source clock is then subdivided by a ratio of 2^8 to 2^{18} to give longer timeouts, the actual value being chosen using the WS2~WS0 bits in the WDTC register.

Watchdog Timer Control Register

A single register, WDTC, controls the required timeout period as well as the enable/disable and reset MCU operation. The WRF software reset flag will be indicated in the RSTFC register. These registers control the overall operation of the Watchdog Timer.

• WDTC Register

Bit	7	6	5	4	3	2	1	0
Name	WE4	WE3	WE2	WE1	WE0	WS2	WS1	WS0
R/W	R/W	R/W	R/W	R/W	R/W	R/W	R/W	R/W
POR	0	1	0	1	0	0	1	0

Bit 7~3 **WE4~WE0**: WDT function software control

10101: Disable
01010: Enable
Others: Reset MCU

When these bits are changed by the environmental noise or software setting to reset the microcontroller, the reset operation will be activated after a delay time, t_{SRESET} , and the WRF bit in the RSTFC register will be set high.

Bit 2~0 **WS2~WS0**: WDT time-out period selection

000: $2^8/f_{WDT}$
001: $2^{10}/f_{WDT}$
010: $2^{12}/f_{WDT}$
011: $2^{14}/f_{WDT}$
100: $2^{15}/f_{WDT}$
101: $2^{16}/f_{WDT}$
110: $2^{17}/f_{WDT}$
111: $2^{18}/f_{WDT}$

These three bits determine the division ratio of the watchdog timer source clock, which in turn determines the time-out period. The internal clock, f_{WDT} is supplied by the LXT oscillator with the output frequency of $f_{LXT}/8$.

• RSTFC Register

Bit	7	6	5	4	3	2	1	0
Name	—	—	—	—	RSTF	LVRF	LRF	WRF
R/W	—	—	—	—	R/W	R/W	R/W	R/W
POR	—	—	—	—	0	x	0	0

“x”: unknown

Bit 7~4 Unimplemented, read as “0”

Bit 3 **RSTF**: Reset control register software reset flag
Described elsewhere

- Bit 2 **LVRF**: LVR function reset flag
Described elsewhere
- Bit 1 **LRF**: LVR Control Register Software Reset Flag
Described elsewhere
- Bit 0 **WRF**: WDT Control Register Software Reset Flag
0: Not occur
1: Occurred

This bit is set high by the WDT Control register software reset and cleared to zero by the application program. Note that this bit can only be cleared to zero by the application program.

Watchdog Timer Operation

The Watchdog Timer operates by providing a device reset when its timer overflows. This means that in the application program and during normal operation the user has to strategically clear the Watchdog Timer before it overflows to prevent the Watchdog Timer from executing a reset. This is done using the clear watchdog instruction. If the program malfunctions for whatever reason, jumps to an unknown location, or enters an endless loop, the clear instruction will not be executed in the correct manner, in which case the Watchdog Timer will overflow and reset the device. There are five bits, WE4~WE0, in the WDTC register to offer the enable/disable control and reset control of the Watchdog Timer. The WDT function will be disabled when the WE4~WE0 bits are set to a value of 10101B while the WDT function will be enabled if the WE4~WE0 bits are equal to 01010B. If the WE4~WE0 bits are set to any other values, other than 01010B and 10101B, it will reset the device after a delay time, t_{RESET} . After power on these bits will have a value of 01010B.

WE4~WE0 Bits	WDT Function
10101B	Disable
01010B	Enable
Any other values	Reset MCU

Watchdog Timer Enable/Disable Control

Under normal program operation, a Watchdog Timer time-out will initialise a device reset and set the status bit TO. However, if the system is in the SLEEP or IDLE Mode, when a Watchdog Timer time-out occurs, the TO bit in the status register will be set and only the Program Counter and Stack Pointer will be reset. Four methods can be adopted to clear the contents of the Watchdog Timer. The first is a WDT reset, which means a certain value except 01010B and 10101B written into the WE4~WE0 bit filed, the second is using the Watchdog Timer software clear instruction and the third is via a HALT instruction. The last is an external hardware reset, which means a low level on the external reset pin if the external reset pin is selected by the RSTC register.

There is only one method of using software instruction to clear the Watchdog Timer. That is to use the single “CLR WDT” instruction to clear the WDT.

The maximum time out period is when the 2^{18} division ratio is selected. As an example, the Watchdog Timer clock source is provided by the internal clock, f_{WDT} , which is supplied by the LXT oscillator with the output frequency of $f_{\text{LXT}}/8$, this will give a maximum watchdog period of around 64 seconds for the 2^{18} division ratio, and a minimum timeout of 62.5ms for the 2^8 division ration.

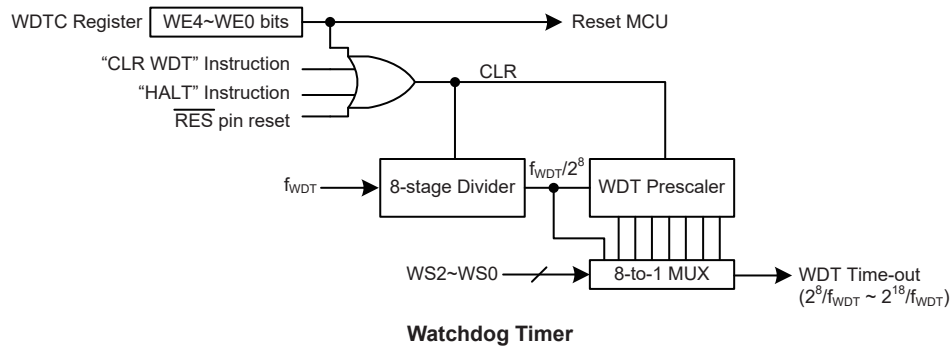

Reset and Initialisation

A reset function is a fundamental part of any microcontroller ensuring that the device can be set to some predetermined condition irrespective of outside parameters. The most important reset condition is after power is first applied to the microcontroller. In this case, internal circuitry will ensure that the microcontroller, after a short delay, will be in a well-defined state and ready to execute the first program instruction. After this power-on reset, certain important internal registers will be set to defined states before the program commences. One of these registers is the Program Counter, which will be reset to zero forcing the microcontroller to begin program execution from the lowest Program Memory address.

In addition to the power-on reset, situations may arise where it is necessary to forcefully apply a reset condition when the microcontroller is already running, the RES line is forcefully pulled low. In such a case, known as a normal operation reset, some of the microcontroller registers remain unchanged allowing the microcontroller to proceed with normal operation after the reset line is allowed to return high.

The Watchdog Timer overflow is one of many reset types and will reset the microcontroller. Another reset exists in the form of a Low Voltage Reset, LVR, where a full reset, similar to the RES reset is implemented in situations where the power supply voltage falls below a certain threshold. All types of reset operations result in different register conditions being setup.

Reset Functions

There are several ways in which a microcontroller reset can occur, through events occurring both internally and externally.

Power-on Reset

The most fundamental and unavoidable reset is the one that occurs after power is first applied to the microcontroller. As well as ensuring that the Program Memory begins execution from the first memory address, a power-on reset also ensures that certain other registers are preset to known conditions. All the I/O port and port control registers will power up in a high condition ensuring that all I/O ports will be first set to inputs.

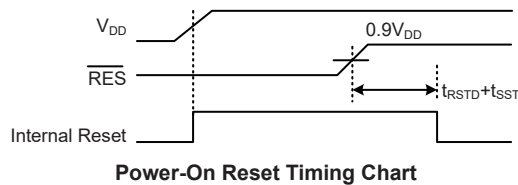

RES Pin Reset

Although the microcontroller has an internal RC reset function, if the V_{DD} power supply rise time is not fast enough or does not stabilise quickly at power-on, the internal reset function may be incapable of providing proper reset operation. For this reason it is recommended that an external RC network is connected to the \overline{RES} pin, whose additional time delay will ensure that the \overline{RES} pin remains low for an extended period to allow the power supply to stabilise. During this time delay, normal operation of the microcontroller will be inhibited. After the \overline{RES} line reaches a certain voltage value, the reset delay time, t_{RSTD} , is invoked to provide an extra delay time after which the microcontroller will begin normal operation. The abbreviation SST in the figures stands for System Start-up Time. For most applications a resistor connected between V_{DD} and the \overline{RES} line and a capacitor connected between V_{SS} and the \overline{RES} pin will provide a suitable external reset circuit. Any wiring connected to the \overline{RES} pin should be kept as short as possible to minimise any stray noise interference. For applications that operate within an environment where more noise is present the Enhanced Reset Circuit shown is recommended.

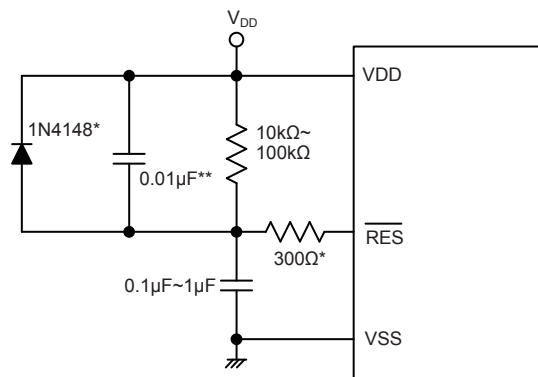

Note: “*” It is recommended that this component is added for added ESD protection.

“**” It is recommended that this component is added in environments where power line noise is significant.

External \overline{RES} Circuit

Pulling the \overline{RES} pin low using external hardware will also execute a device reset. In this case, as in the case of other resets, the Program Counter will reset to zero and program execution initiated from this point.

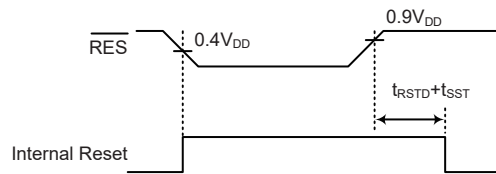

RES Reset Timing Chart

There is an internal reset control register, RSTC, which is used to select the external \overline{RES} pin function and provide a reset when the device operates abnormally due to the environmental noise interference. If the content of the RSTC register is set to any value other than 01010101B or 10101010B, it will reset the device after a delay time, t_{SRESET} . After power on the register will have a value of 01010101B.

RSTC7~RSTC0 Bits	Reset Function
01010101B 10101010B	$\overline{\text{RES}}$
Any other value	Reset MCU

Internal Reset Function Control

• **RSTC Register**

Bit	7	6	5	4	3	2	1	0
Name	RSTC7	RSTC6	RSTC5	RSTC4	RSTC3	RSTC2	RSTC1	RSTC0
R/W	R/W	R/W	R/W	R/W	R/W	R/W	R/W	R/W
POR	0	1	0	1	0	1	0	1

Bit 7~0 **RSTC7~RSTC0**: Reset function control
01010101, 10101010: $\overline{\text{RES}}$ pin
Other values: Reset MCU

If these bits are changed due to adverse environmental conditions, the microcontroller will be reset. The reset operation will be activated after a delay time, t_{SRESET} , and the RSTF bit in the RSTFC register will be set to 1.

All resets will reset this register to POR value except the WDT time out hardware warm reset. Note that if the register is set to 01010101B or 10101010B to select the $\overline{\text{RES}}$ pin, this configuration has higher priority than other related pin-shared controls.

• **RSTFC Register**

Bit	7	6	5	4	3	2	1	0
Name	—	—	—	—	RSTF	LVRF	LRF	WRF
R/W	—	—	—	—	R/W	R/W	R/W	R/W
POR	—	—	—	—	0	x	0	0

“x”: unknown

Bit 7~4 Unimplemented, read as “0”

Bit 3 **RSTF**: Reset control register software reset flag
0: Not occurred
1: Occurred

This bit is set to 1 by the RSTC control register software reset and cleared to zero by the application program. Note that this bit can only be cleared to 0 by the application program.

Bit 2 **LVRF**: LVR function reset flag
Described elsewhere

Bit 1 **LRF**: LVR control register software reset flag
Described elsewhere

Bit 0 **WRF**: WDT control register software reset flag
Described elsewhere

Low Voltage Reset – LVR

The microcontroller contains a low voltage reset circuit in order to monitor the supply voltage of the device and provides an MCU reset should the value fall below a certain predefined level.

This function can be enabled or disabled by the LVRC control register. If the LVRC control register is configured to enable the LVR, the LVR function will be always enabled, except in the SLEEP/IDLE mode, with a specific LVR voltage V_{LVR} . If the supply voltage of the device drops to within a range of $0.9V \sim V_{\text{LVR}}$ such as might occur when changing the battery, the LVR will automatically reset the device internally and the LVRF bit in the RSTFC register will also be set high. For a valid LVR signal, a low supply voltage, i.e., a voltage in the range between $0.9V \sim V_{\text{LVR}}$ must exist for a

time greater than that specified by t_{LVR} in the LVD/LVR Electrical Characteristics. If the low supply voltage state does not exceed this value, the LVR will ignore the low supply voltage and will not perform a reset function. The actual V_{LVR} value can be selected by the LVS7~LVS0 bits in the LVRC register. If the LVS7~LVS0 bits are changed to some certain values by the environmental noise or software setting, the LVR will reset the device after a delay time, t_{SRESET} . When this happens, the LRF bit in the RSTFC register will be set high. After power on the register will have the value of 01100110B. Note that the LVR function will be automatically disabled when the device enters the IDLE/SLEEP mode.

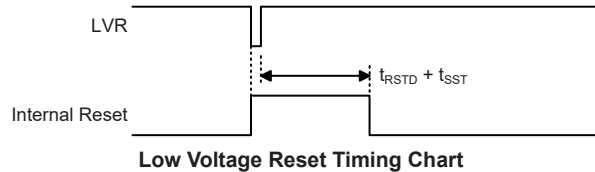

• **LVRC Register**

Bit	7	6	5	4	3	2	1	0
Name	LVS7	LVS6	LVS5	LVS4	LVS3	LVS2	LVS1	LVS0
R/W	R/W	R/W	R/W	R/W	R/W	R/W	R/W	R/W
POR	0	1	1	0	0	1	1	0

Bit 7~0 **LVS7~LVS0**: LVR voltage select
 01100110B: 1.7V
 01010101B: 1.9V
 00110011B: 2.55V
 10011001B: 3.15V
 10101010B: 3.8V
 11110000B: LVR disable

Other values: MCU reset – register is reset to POR value

When an actual low voltage condition occurs, as specified by one of the five defined LVR voltage values above, an MCU reset will be generated. The reset operation will be activated after the low voltage condition keeps more than a t_{LVR} time. In this situation the register contents will remain the same after such a reset occurs.

Any register value, other than the five defined LVR values above, will also result in the generation of an MCU reset. The reset operation will be activated after a delay time, t_{SRESET} . However in this situation the register contents will be reset to the POR value.

• **RSTFC Register**

Bit	7	6	5	4	3	2	1	0
Name	—	—	—	—	RSTF	LVRF	LRF	WRF
R/W	—	—	—	—	R/W	R/W	R/W	R/W
POR	—	—	—	—	0	x	0	0

“x”: unknown

Bit 7~4 Unimplemented, read as “0”

Bit 3 **RSTF**: Reset control register software reset flag
 Described elsewhere

Bit 2 **LVRF**: LVR function reset flag
 0: Not occur
 1: Occurred

This bit is set high when a specific Low Voltage Reset situation condition occurs. This bit can only be cleared to zero by the application program.

- Bit 1 **LRF:** LVR control register software reset flag
 0: Not occur
 1: Occurred
 This bit is set high if the LVRC register contains any non-defined LVR voltage register values. This in effect acts like a software-reset function. This bit can only be cleared to zero by the application program.

- Bit 0 **WRF:** WDT Control register software reset flag
 Described elsewhere

In Application Programming Reset

When a specific value of “55H” is written into the FC1 register, a reset signal will be generated to reset the whole device. Refer to the IAP section for more associated details.

Watchdog Time-out Reset during Normal Operation

The Watchdog time-out flag TO will be set to “1” when Watchdog time-out Reset during normal operation.

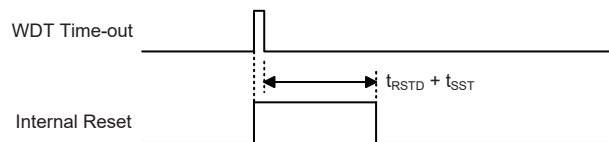

WDT Time-out Reset during Normal Operation Timing Chart

Watchdog Time-out Reset during SLEEP or IDLE Mode

The Watchdog time-out Reset during SLEEP or IDLE Mode is a little different from other kinds of reset. Most of the conditions remain unchanged except that the Program Counter and the Stack Pointer will be cleared to zero and the TO flag will be set high. Refer to the System Start Up Time Characteristics for t_{SST} details.

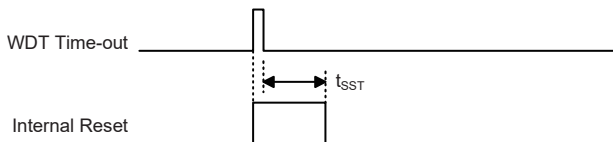

WDT Time-out Reset during Sleep or IDLE Mode Timing Chart

Reset Initial Conditions

The different types of reset described affect the reset flags in different ways. These flags, known as PDF and TO are located in the status register and are controlled by various microcontroller operations, such as the SLEEP or IDLE Mode function or Watchdog Timer. The reset flags are shown in the table:

TO	PDF	Reset Conditions
0	0	Power-on reset
u	u	\overline{RES} or LVR reset during FAST or SLOW Mode operation
1	u	WDT time-out reset during FAST or SLOW Mode operation
1	1	WDT time-out reset during IDLE or SLEEP Mode operation

“u” stands for unchanged

The following table indicates the way in which the various components of the microcontroller are affected after a power-on reset occurs.

Item	Condition after Reset
Program Counter	Reset to zero
Interrupts	All interrupts will be disabled
WDT, Time Bases	Clear after reset, WDT begins counting
Timer Modules	Timer Modules will be turned off
Input/Output Ports	I/O ports will be setup as inputs
Stack Pointer	Stack Pointer will point to the top of the stack

The different kinds of resets all affect the internal registers of the microcontroller in different ways. To ensure reliable continuation of normal program execution after a reset occurs, it is important to know what condition the microcontroller is in after a particular reset occurs. The following table describes how each type of reset affects each of the microcontroller internal registers.

Register	Reset (Power On)	RES Reset (Normal Operation)	LVR Reset (Normal Operation)	WDT Time-out (Normal Operation)	WDT Time-out (IDLE/SLEEP)
IAR0	0000 0000	0000 0000	0000 0000	0000 0000	uuuu uuuu
MP0	0000 0000	0000 0000	0000 0000	0000 0000	uuuu uuuu
IAR1	0000 0000	0000 0000	0000 0000	0000 0000	uuuu uuuu
MP1L	0000 0000	0000 0000	0000 0000	0000 0000	uuuu uuuu
MP1H	0000 0000	0000 0000	0000 0000	0000 0000	uuuu uuuu
ACC	xxxx xxxx	uuuu uuuu	uuuu uuuu	uuuu uuuu	uuuu uuuu
PCL	0000 0000	0000 0000	0000 0000	0000 0000	0000 0000
TBLP	xxxx xxxx	uuuu uuuu	uuuu uuuu	uuuu uuuu	uuuu uuuu
TBLH	xxxx xxxx	uuuu uuuu	uuuu uuuu	uuuu uuuu	uuuu uuuu
TBHP	--xx xxxx	--uu uuuu	--uu uuuu	--uu uuuu	--uu uuuu
STATUS	xx00 xxxx	uuuu uuuu	uuuu uuuu	uu1u uuuu	uu11 uuuu
PBP	---- ---0	---- ---0	---- ---0	---- ---0	---- ---u
IAR2	0000 0000	0000 0000	0000 0000	0000 0000	uuuu uuuu
MP2L	0000 0000	0000 0000	0000 0000	0000 0000	uuuu uuuu
MP2H	0000 0000	0000 0000	0000 0000	0000 0000	uuuu uuuu
RSTFC	---- 0x00	---- uuuu	---- u1uu	---- uuuu	---- uuuu
INTC0	-000 0000	-000 0000	-000 0000	-000 0000	-uuu uuuu
INTC1	0000 0000	0000 0000	0000 0000	0000 0000	uuuu uuuu
INTC2	0000 0000	0000 0000	0000 0000	0000 0000	uuuu uuuu
INTC3	-000 -000	-000 -000	-000 -000	-000 -000	-uuu -uuu
PA	1111 1111	1111 1111	1111 1111	1111 1111	uuuu uuuu
PAC	1111 1111	1111 1111	1111 1111	1111 1111	uuuu uuuu
PAPU	0000 0000	0000 0000	0000 0000	0000 0000	uuuu uuuu
PAWU	0000 0000	0000 0000	0000 0000	0000 0000	uuuu uuuu
PB	1111 1111	1111 1111	1111 1111	1111 1111	uuuu uuuu
PBC	1111 1111	1111 1111	1111 1111	1111 1111	uuuu uuuu
PBPU	0000 0000	0000 0000	0000 0000	0000 0000	uuuu uuuu
PC	---- 1111	---- 1111	---- 1111	---- 1111	---- uuuu
PCC	---- 1111	---- 1111	---- 1111	---- 1111	---- uuuu
PCPU	---- 0000	---- 0000	---- 0000	---- 0000	---- uuuu
PSC0R	---- ---0	---- ---0	---- ---0	---- ---0	---- ---u
PSC1R	---- ---0	---- ---0	---- ---0	---- ---0	---- ---u

Register	Reset (Power On)	RES Reset (Normal Operation)	LVR Reset (Normal Operation)	WDT Time-out (Normal Operation)	WDT Time-out (IDLE/SLEEP)
SADOL	x x x x - - - -	x x x x - - - -	x x x x - - - -	x x x x - - - -	u u u u - - - - (ADRF5=0) u u u u u u u u (ADRF5=1)
SADOH	x x x x x x x x	x x x x x x x x	x x x x x x x x	x x x x x x x x	u u u u u u u u (ADRF5=0) - - - - u u u u (ADRF5=1)
SADC0	0 0 0 0 0 0 0 0	0 0 0 0 0 0 0 0	0 0 0 0 0 0 0 0	0 0 0 0 0 0 0 0	u u u u u u u u
SADC1	0 0 0 0 0 0 0 0	0 0 0 0 0 0 0 0	0 0 0 0 0 0 0 0	0 0 0 0 0 0 0 0	u u u u u u u u
SADC2	0 - - - - 1 0	0 - - - - 1 0	0 - - - - 1 0	0 - - - - 1 0	u - - - - - u u
RSTC	0 1 0 1 0 1 0 1	0 1 0 1 0 1 0 1	0 1 0 1 0 1 0 1	0 1 0 1 0 1 0 1	u u u u u u u u
PMPS	- - - - - 0 0	- - - - - 0 0	- - - - - 0 0	- - - - - 0 0	- - - - - u u
LVPUC	- - - - - 0	- - - - - 0	- - - - - 0	- - - - - 0	- - - - - u
MF10	0 0 0 0 0 0 0 0	0 0 0 0 0 0 0 0	0 0 0 0 0 0 0 0	0 0 0 0 0 0 0 0	u u u u u u u u
MF11	- - 0 0 - - 0 0	- - 0 0 - - 0 0	- - 0 0 - - 0 0	- - 0 0 - - 0 0	- - u u - - u u
MF12	- - 0 0 - - 0 0	- - 0 0 - - 0 0	- - 0 0 - - 0 0	- - 0 0 - - 0 0	- - u u - - u u
INTEG	0 0 0 0 0 0 0 0	0 0 0 0 0 0 0 0	0 0 0 0 0 0 0 0	0 0 0 0 0 0 0 0	u u u u u u u u
SCC	0 0 1 - - - 0 0	0 0 1 - - - 0 0	0 0 1 - - - 0 0	0 0 1 - - - 0 0	u u u - - - u u
HIRCC	- - - - 0 0 0 1	- - - - 0 0 0 1	- - - - 0 0 0 1	- - - - 0 0 0 1	- - - - u u u u
LXTC	- - - - - 0 1	- - - - - 0 1	- - - - - 0 1	- - - - - 0 1	- - - - - u u
WDTC	0 1 0 1 0 0 1 0	0 1 0 1 0 0 1 0	0 1 0 1 0 0 1 0	0 1 0 1 0 0 1 0	u u u u u u u u
LVRC	0 1 1 0 0 1 1 0	0 1 1 0 0 1 1 0	0 1 1 0 0 1 1 0	0 1 1 0 0 1 1 0	u u u u u u u u
LVDC	- - 0 0 0 0 0 0	- - 0 0 0 0 0 0	- - 0 0 0 0 0 0	- - 0 0 0 0 0 0	- - u u u u u u
EEA	- 0 0 0 0 0 0 0 0	- 0 0 0 0 0 0 0 0	- 0 0 0 0 0 0 0 0	- 0 0 0 0 0 0 0 0	- u u u u u u u
EED	0 0 0 0 0 0 0 0	0 0 0 0 0 0 0 0	0 0 0 0 0 0 0 0	0 0 0 0 0 0 0 0	u u u u u u u u
PAS0	0 0 - - 0 0 - -	0 0 - - 0 0 - -	0 0 - - 0 0 - -	0 0 - - 0 0 - -	u u - - u u - -
PAS1	0 0 0 0 0 0 0 0	0 0 0 0 0 0 0 0	0 0 0 0 0 0 0 0	0 0 0 0 0 0 0 0	u u u u u u u u
PBS0	0 0 0 0 0 0 0 0	0 0 0 0 0 0 0 0	0 0 0 0 0 0 0 0	0 0 0 0 0 0 0 0	u u u u u u u u
PBS1	0 0 0 0 0 0 0 0	0 0 0 0 0 0 0 0	0 0 0 0 0 0 0 0	0 0 0 0 0 0 0 0	u u u u u u u u
PCS0	0 0 0 0 0 0 0 0	0 0 0 0 0 0 0 0	0 0 0 0 0 0 0 0	0 0 0 0 0 0 0 0	u u u u u u u u
STMC0	0 0 0 0 0 - - -	0 0 0 0 0 - - -	0 0 0 0 0 - - -	0 0 0 0 0 - - -	u u u u u - - -
STMC1	0 0 0 0 0 0 0 0	0 0 0 0 0 0 0 0	0 0 0 0 0 0 0 0	0 0 0 0 0 0 0 0	u u u u u u u u
STMDL	0 0 0 0 0 0 0 0	0 0 0 0 0 0 0 0	0 0 0 0 0 0 0 0	0 0 0 0 0 0 0 0	u u u u u u u u
STMDH	0 0 0 0 0 0 0 0	0 0 0 0 0 0 0 0	0 0 0 0 0 0 0 0	0 0 0 0 0 0 0 0	u u u u u u u u
STMAL	0 0 0 0 0 0 0 0	0 0 0 0 0 0 0 0	0 0 0 0 0 0 0 0	0 0 0 0 0 0 0 0	u u u u u u u u
STMAH	0 0 0 0 0 0 0 0	0 0 0 0 0 0 0 0	0 0 0 0 0 0 0 0	0 0 0 0 0 0 0 0	u u u u u u u u
STMRP	0 0 0 0 0 0 0 0	0 0 0 0 0 0 0 0	0 0 0 0 0 0 0 0	0 0 0 0 0 0 0 0	u u u u u u u u
CTM0C0	0 0 0 0 0 0 0 0	0 0 0 0 0 0 0 0	0 0 0 0 0 0 0 0	0 0 0 0 0 0 0 0	u u u u u u u u
CTM0C1	0 0 0 0 0 0 0 0	0 0 0 0 0 0 0 0	0 0 0 0 0 0 0 0	0 0 0 0 0 0 0 0	u u u u u u u u
CTM0DL	0 0 0 0 0 0 0 0	0 0 0 0 0 0 0 0	0 0 0 0 0 0 0 0	0 0 0 0 0 0 0 0	u u u u u u u u
CTM0DH	- - - - - 0 0	- - - - - 0 0	- - - - - 0 0	- - - - - 0 0	- - - - - u u
CTM0AL	0 0 0 0 0 0 0 0	0 0 0 0 0 0 0 0	0 0 0 0 0 0 0 0	0 0 0 0 0 0 0 0	u u u u u u u u
CTM0AH	- - - - - 0 0	- - - - - 0 0	- - - - - 0 0	- - - - - 0 0	- - - - - u u
CTM1C0	0 0 0 0 0 0 0 0	0 0 0 0 0 0 0 0	0 0 0 0 0 0 0 0	0 0 0 0 0 0 0 0	u u u u u u u u
CTM1C1	0 0 0 0 0 0 0 0	0 0 0 0 0 0 0 0	0 0 0 0 0 0 0 0	0 0 0 0 0 0 0 0	u u u u u u u u
CTM1DL	0 0 0 0 0 0 0 0	0 0 0 0 0 0 0 0	0 0 0 0 0 0 0 0	0 0 0 0 0 0 0 0	u u u u u u u u
CTM1DH	- - - - - 0 0	- - - - - 0 0	- - - - - 0 0	- - - - - 0 0	- - - - - u u

Register	Reset (Power On)	RES Reset (Normal Operation)	LVR Reset (Normal Operation)	WDT Time-out (Normal Operation)	WDT Time-out (IDLE/SLEEP)
CTM1AL	0000 0000	0000 0000	0000 0000	0000 0000	u u u u u u u u
CTM1AH	---- --00	---- --00	---- --00	---- --00	---- --u u
TB0C	0--- -000	0--- -000	0--- -000	0--- -000	u--- -u u u
TB1C	0--- -000	0--- -000	0--- -000	0--- -000	u--- -u u u
SIMC0	1110 0000	1110 0000	1110 0000	1110 0000	u u u u u u u u
SIMC1 (UMD=0)	1000 0001	1000 0001	1000 0001	1000 0001	u u u u u u u u
UUCR1* (UMD=1)	0000 00x0	0000 00x0	0000 00x0	0000 00x0	u u u u u u u u
SIMD/UTXR_RXR	xxxx xxxx	xxxx xxxx	xxxx xxxx	xxxx xxxx	u u u u u u u u
SIMA/SIMC2/ UUCR2	0000 0000	0000 0000	0000 0000	0000 0000	u u u u u u u u
SIMTOC (UMD=0)	0000 0000	0000 0000	0000 0000	0000 0000	u u u u u u u u
UBRG* (UMD=1)	xxxx xxxx	xxxx xxxx	xxxx xxxx	xxxx xxxx	u u u u u u u u
UUSR	0000 1011	0000 1011	0000 1011	0000 1011	u u u u u u u u
SPIAC0	111- --00	111- --00	111- --00	111- --00	u u u - - - u u
SPIAC1	--00 0000	--00 0000	--00 0000	--00 0000	--u u u u u u
SPIAD	xxxx xxxx	xxxx xxxx	xxxx xxxx	xxxx xxxx	u u u u u u u u
FARL	0000 0000	0000 0000	0000 0000	0000 0000	u u u u u u u u
FARH	--00 0000	--00 0000	--00 0000	--00 0000	--u u u u u u
FD0L	0000 0000	0000 0000	0000 0000	0000 0000	u u u u u u u u
FD0H	0000 0000	0000 0000	0000 0000	0000 0000	u u u u u u u u
FD1L	0000 0000	0000 0000	0000 0000	0000 0000	u u u u u u u u
FD1H	0000 0000	0000 0000	0000 0000	0000 0000	u u u u u u u u
FD2L	0000 0000	0000 0000	0000 0000	0000 0000	u u u u u u u u
FD2H	0000 0000	0000 0000	0000 0000	0000 0000	u u u u u u u u
FD3L	0000 0000	0000 0000	0000 0000	0000 0000	u u u u u u u u
FD3H	0000 0000	0000 0000	0000 0000	0000 0000	u u u u u u u u
EEC	---- 0000	---- 0000	---- 0000	---- 0000	---- u u u u
FC0	0000 0000	0000 0000	0000 0000	0000 0000	u u u u u u u u
FC1	0000 0000	0000 0000	0000 0000	0000 0000	u u u u u u u u
FC2	---- ---0	---- ---0	---- ---0	---- ---0	---- ---u
EPDC0	0--- -000	0--- -000	0--- -000	0--- -000	u--- -u u u
EPDC1	-111 0011	-111 0011	-111 0011	-111 0011	-u u u u u u u
EPDC2	--10 -011	--10 -011	--10 -011	--10 -011	--u u -u u u
VDH_LV	-111 1111	-111 1111	-111 1111	-111 1111	-u u u u u u u
VDL_LV	-111 1111	-111 1111	-111 1111	-111 1111	-u u u u u u u
LUT Registers**	0000 0000	0000 0000	0000 0000	0000 0000	u u u u u u u u
PEPD0~PEPD7	0000 0000	0000 0000	0000 0000	0000 0000	u u u u u u u u
PEPDBG	0 --- ----	0 --- ----	0 --- ----	0 --- ----	u --- ----
NEPD0~NEPD7	0000 0000	0000 0000	0000 0000	0000 0000	u u u u u u u u
NEPDBG	0 --- ----	0 --- ----	0 --- ----	0 --- ----	u --- ----

Note: “u” stands for unchanged

“x” stands for unknown

“-” stands for unimplemented

“*”: The UUCR1 and SIMC1 registers share the same memory address while the UBRG and SIMTOC registers share the same memory address. The default value of the UUCR1 or UBRG register can be obtained when the UMD bit is set high by application program after a reset.

“**”: The LUT registers have a total of 75 bytes, with the same reset value for each byte, the details can be found in the EPD Driver Registers section.

Input/Output Ports

Holtek microcontrollers offer considerable flexibility on their I/O ports. With the input or output designation of every pin fully under user program control, pull-high selections for all ports and wake-up selections on certain pins, the user is provided with an I/O structure to meet the needs of a wide range of application possibilities.

The device provides bidirectional input/output lines labeled with port names PA~PC. These I/O ports are mapped to the RAM Data Memory with specific addresses as shown in the Special Purpose Data Memory table. All of these I/O ports can be used for input and output operations. For input operation, these ports are non-latching, which means the inputs must be ready at the T2 rising edge of instruction “MOV A, [m]”, where m denotes the port address. For output operation, all the data is latched and remains unchanged until the output latch is rewritten.

Register Name	Bit							
	7	6	5	4	3	2	1	0
PA	PA7	PA6	PA5	PA4	PA3	PA2	PA1	PA0
PAC	PAC7	PAC5	PAC5	PAC4	PAC3	PAC2	PAC1	PAC0
PAPU	PAPU7	PAPU4	PAPU5	PAPU4	PAPU3	PAPU2	PAPU1	PAPU0
PAWU	PAWU7	PAWU6	PAWU5	PAWU4	PAWU3	PAWU2	PAWU1	PAWU0
PB	PB7	PB6	PB5	PB4	PB3	PB2	PB1	—
PBC	PBC7	PBC6	PBC5	PBC4	PBC3	PBC2	PBC1	—
PBPU	PBPU7	PBPU6	PBPU5	PBPU4	PBPU3	PBPU2	PBPU1	—
PC	—	—	—	—	PC3	PC2	PC1	PC0
PCC	—	—	—	—	PCC3	PCC2	PCC1	PCC0
PCPU	—	—	—	—	PCPU3	PCPU2	PCPU1	PCPU0
LVPUC	—	—	—	—	—	—	—	LVPUC

“—”: Unimplemented, read as “0”

I/O Logic Function Register List

Pull-high Resistors

Many product applications require pull-high resistors for their switch inputs usually requiring the use of an external resistor. To eliminate the need for these external resistors, all I/O pins, when configured as a digital input have the capability of being connected to an internal pull-high resistor. These pull-high resistors are selected using the LVPUC and PxPU registers, and are implemented using weak PMOS transistors. The PxPU registers is used to determine whether the pull-high function is enabled or not while the LVPUC register is used to select the pull-high resistors value for low voltage power supply applications.

Note that the pull-high resistor can be controlled by the relevant pull-high control register only when the pin-shared functional pin is selected as a digital input or NMOS output. Otherwise, the pull-high resistors cannot be enabled.

• PxPU Register

Bit	7	6	5	4	3	2	1	0
Name	PxPU7	PxPU6	PxPU5	PxPU4	PxPU3	PxPU2	PxPU1	PxPU0
R/W	R/W	R/W	R/W	R/W	R/W	R/W	R/W	R/W
POR	0	0	0	0	0	0	0	0

PxPUN: I/O Port x Pin Pull-high Function Control

0: Disable

1: Enable

The PxPUN bit is used to control the pin pull-high function. Here the “x” can be A, B and C. However, the actual available bits for each I/O port may be different.

• **LVPU Register**

Bit	7	6	5	4	3	2	1	0
Name	—	—	—	—	—	—	—	LVPU
R/W	—	—	—	—	—	—	—	R/W
POR	—	—	—	—	—	—	—	0

Bit 7~1 Unimplemented, read as “0”

Bit 0 **LVPU**: Pull-high resistor select when low voltage power supply

0: All pin pull high resistor is 60kΩ (typ.) @ 3V

1: All pin pull high resistor is 15kΩ (typ.) @ 3V

This bit is used to select the pull-high resistor value for low voltage power supply applications. The LVPU bit is only available when the corresponding pin pull-high function is enabled by setting the relevant pull-high control bit high. This bit will have no effect when the pull-high function is disabled.

Port A Wake-up

The HALT instruction forces the microcontroller into the SLEEP or IDLE Mode which preserves power, a feature that is important for battery and other low-power applications. Various methods exist to wake-up the microcontroller, one of which is to change the logic condition on one of the Port A pins from high to low. This function is especially suitable for applications that can be woken up via external switches. Each pin on Port A can be selected individually to have this wake-up feature using the PAWU register.

Note that the wake-up function can be controlled by the wake-up control registers only when the pin-shared functional pin is selected as general purpose input/output and the MCU enters the IDLE or SLEEP down mode.

• **PAWU Register**

Bit	7	6	5	4	3	2	1	0
Name	PAWU7	PAWU6	PAWU5	PAWU4	PAWU3	PAWU2	PAWU1	PAWU0
R/W	R/W	R/W	R/W	R/W	R/W	R/W	R/W	R/W
POR	0	0	0	0	0	0	0	0

Bit 7~0 **PAWU7~PAWU0**: PA7~PA0 wake-up function control

0: Disable

1: Enable

I/O Port Control Registers

Each I/O port has its own control register which controls the input/output configuration. With this control register, each CMOS output or input can be reconfigured dynamically under software control. Each pin of the I/O ports is directly mapped to a bit in its associated port control register. For the I/O pin to function as an input, the corresponding bit of the control register must be written as a “1”. This will then allow the logic state of the input pin to be directly read by instructions. When the corresponding bit of the control register is written as a “0”, the I/O pin will be setup as a CMOS output. If the pin is currently setup as an output, instructions can still be used to read the output register. However, it should be noted that the program will in fact only read the status of the output data latch and not the actual logic status of the output pin.

• **PxC Register**

Bit	7	6	5	4	3	2	1	0
Name	PxC7	PxC5	PxC5	PxC4	PxC3	PxC2	PxC1	PxC0
R/W	R/W	R/W	R/W	R/W	R/W	R/W	R/W	R/W
POR	1	1	1	1	1	1	1	1

PxCn: I/O Port x Pin Type Selection

0: Output

1: Input

The PxCn bit is used to control the pin type selection. Here the “x” can be A, B and C. However, the actual available bits for each I/O port may be different.

I/O Port Power Source Control

The device supports different I/O port power source selections for PC3~PC0. The port power can come from either the power pin VDD or VDDIO which is determined using the PMPS1~PMPS0 bits in the PMPS register. The VDDIO power pin function should first be selected using the corresponding pin-shared function selection bits if the port power is supposed to come from the VDDIO pin. An important point to know is that the input power voltage on the VDDIO pin should be equal to or less than the device supply power voltage when the VDDIO pin is selected as the port power supply pin.

• **PMPS Register**

Bit	7	6	5	4	3	2	1	0
Name	—	—	—	—	—	—	PMPS1	PMPS0
R/W	—	—	—	—	—	—	R/W	R/W
POR	—	—	—	—	—	—	0	0

Bit 7~2 Unimplemented, read as “0”

Bit 1~0 **PMPS1~PMPS0:** PC3~PC0 pin power source selection

0x: VDD

1x: VDDIO

If the PA3 pin-shared function is switched to the VDDIO function, the VDDIO input voltage can be used as the PC3~PC0 I/O port power source by setting the PMPS[1:0] bit field to “1x”. Note that the input power voltage on the VDDIO pin should be equal to or less than the device supply power voltage.

Pin-shared Functions

The flexibility of the microcontroller range is greatly enhanced by the use of pins that have more than one function. Limited numbers of pins can force serious design constraints on designers but by supplying pins with multi-functions, many of these difficulties can be overcome. For these pins, the desired function of the multi-function I/O pins is selected by a series of registers via the application program control.

Pin-shared Function Selection Registers

The limited number of supplied pins in a package can impose restrictions on the amount of functions a certain device can contain. However by allowing the same pins to share several different functions and providing a means of function selection, a wide range of different functions can be incorporated into even relatively small package sizes. The device includes Port “x” output function Selection register “n”, labeled as PxCn, which can select the desired functions of the multi-function pin-shared pins.

The most important point to note is to make sure that the desired pin-shared function is properly selected and also deselected. For most pin-shared functions, to select the desired pin-shared function, the pin-shared function should first be correctly selected using the corresponding pin-shared control register. After that the corresponding peripheral functional setting should be configured and then the peripheral function can be enabled. However, special point must be noted for some digital input pins, such as INTn, xTCKn, etc, which share the same pin-shared control configuration with their corresponding general purpose I/O functions when setting the relevant functions, in addition to the necessary pin-shared control and peripheral functional setup aforementioned, they must also be setup as input by setting the corresponding bit in the I/O port control register. To correctly deselect the pin-shared function, the peripheral function should first be disabled and then the corresponding pin-shared function control register can be modified to select other pin-shared functions.

Register Name	Bit							
	7	6	5	4	3	2	1	0
PAS0	PAS07	PAS06	—	—	PAS03	PAS02	—	—
PAS1	PAS17	PAS16	PAS15	PAS14	PAS13	PAS12	PAS11	PAS10
PBS0	PBS07	PBS06	PBS05	PBS04	PBS03	PBS02	—	—
PBS1	PBS17	PBS16	PBS15	PBS14	PBS13	PBS12	PBS11	PBS10
PCS0	PCS07	PCS06	PCS05	PCS04	PCS03	PCS02	PCS01	PCS00

Pin-shared Function Selection Register List

• **PAS0 Register**

Bit	7	6	5	4	3	2	1	0
Name	PAS07	PAS06	—	—	PAS03	PAS02	—	—
R/W	R/W	R/W	—	—	R/W	R/W	—	—
POR	0	0	—	—	0	0	—	—

Bit 7~6 **PAS07~PAS06:** PA3 pin-shared function selection
 00/01: PA3
 10: STP
 11: VDDIO

Bit 5~4 Unimplemented, read as “0”

Bit 3~2 **PAS03~PAS02:** PA1 pin-shared function selection
 00/01/10: PA1
 11: CTP1

Bit 1~0 Unimplemented, read as “0”

• **PAS1 Register**

Bit	7	6	5	4	3	2	1	0
Name	PAS17	PAS16	PAS15	PAS14	PAS13	PAS12	PAS11	PAS10
R/W	R/W	R/W	R/W	R/W	R/W	R/W	R/W	R/W
POR	0	0	0	0	0	0	0	0

Bit 7~6 **PAS17~PAS16:** PA7 pin-shared function selection
 00/01/10: PA7
 11: SCKA

Bit 5~4 **PAS15~PAS14:** PA6 pin-shared function selection
 00/01/10: PA6
 11: SDOA

Bit 3~2 **PAS13~PAS12:** PA5 pin-shared function selection
 00/01/10: PA5
 11: SDIA

Bit 1~0 **PAS11~PAS10:** PA4 pin-shared function selection
 00/01/10: PA4
 11: SCSA

• **PBS0 Register**

Bit	7	6	5	4	3	2	1	0
Name	PBS07	PBS06	PBS05	PBS04	PBS03	PBS02	—	—
R/W	R/W	R/W	R/W	R/W	R/W	R/W	—	—
POR	0	0	0	0	0	0	—	—

Bit 7~6 **PBS07~PBS06:** PB3 pin-shared function selection
 00/01: PB3
 10: CTP0
 11: AN3

Bit 5~4 **PBS05~PBS04:** PB2 pin-shared function selection
 00/01/10: PB2/CTCK0
 11: AN2

Bit 3~2 **PBS03~PBS02:** PB1 pin-shared function selection
 00/01: PB1
 10: STPB
 11: AN1

Bit 1~0 Unimplemented, read as “0”

• **PBS1 Register**

Bit	7	6	5	4	3	2	1	0
Name	PBS17	PBS16	PBS15	PBS14	PBS13	PBS12	PBS11	PBS10
R/W	R/W	R/W	R/W	R/W	R/W	R/W	R/W	R/W
POR	0	0	0	0	0	0	0	0

Bit 7~6 **PBS17~PBS16:** PB7 pin-shared function selection
 00/01: PB7/INT3
 10: AN7
 11: VREF

Bit 5~4 **PBS15~PBS14:** PB6 pin-shared function selection
 00/01/10: PB6/INT2/STPI
 11: AN6

Bit 3~2 **PBS13~PBS12:** PB5 pin-shared function selection
 00/01: PB5/INT1
 10: CTP1B
 11: AN5

Bit 1~0 **PBS11~PBS10:** PB4 pin-shared function selection
 00/01: PB4/INT0
 10: CTP0B
 11: AN4

• **PCS0 Register**

Bit	7	6	5	4	3	2	1	0
Name	PCS07	PCS06	PCS05	PCS04	PCS03	PCS02	PCS01	PCS00
R/W	R/W	R/W	R/W	R/W	R/W	R/W	R/W	R/W
POR	0	0	0	0	0	0	0	0

Bit 7~6 **PCS07~PCS06:** PC3 pin-shared function selection
 00/01/10: PC3
 11: SCK/SCL

- Bit 5~4 **PCS05~PCS04:** PC2 pin-shared function selection
 00/01/10: PC2
 11: SDO/TX
- Bit 3~2 **PCS03~PCS02:** PC1 pin-shared function selection
 00/01/10: PC1
 11: SDI/SDA/RX
- Bit 1~0 **PCS01~PCS00:** PC0 pin-shared function selection
 00/01/10: PC0
 11: SCS

I/O Pin Structures

The accompanying diagram illustrates the internal structures of the I/O logic function. As the exact logical construction of the I/O pin will differ from this diagram, it is supplied as a guide only to assist with the functional understanding of the logic function I/O pins. The wide range of pin-shared structures does not permit all types to be shown.

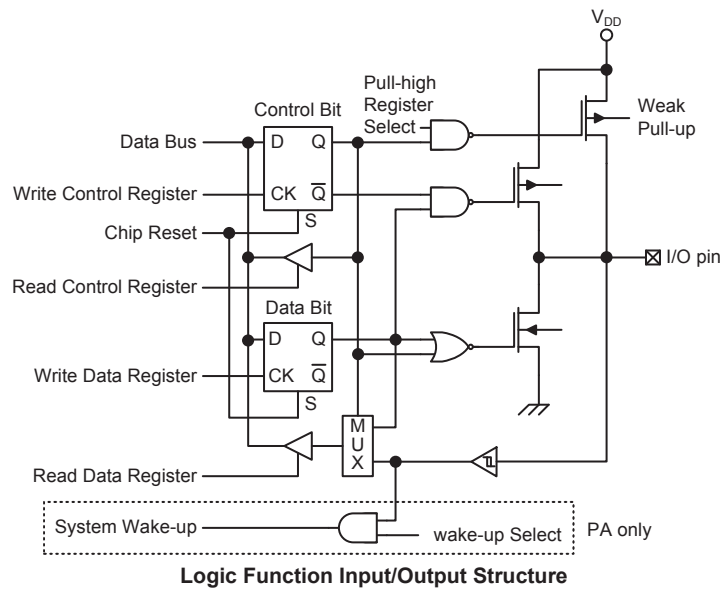

Programming Considerations

Within the user program, one of the things first to consider is port initialisation. After a reset, all of the I/O data and port control registers will be set to high. This means that all I/O pins will be defaulted to an input state, the level of which depends on the other connected circuitry and whether pull-high selections have been chosen. If the port control registers are then programmed to setup some pins as outputs, these output pins will have an initial high output value unless the associated port data registers are first programmed. Selecting which pins are inputs and which are outputs can be achieved byte-wide by loading the correct values into the appropriate port control register or by programming individual bits in the port control register using the "SET [m].i" and "CLR [m].i" instructions. Note that when using these bit control instructions, a read-modify-write operation takes place. The microcontroller must first read in the data on the entire port, modify it to the required new bit values and then rewrite this data back to the output ports.

Port A has the additional capability of providing wake-up functions. When the device is in the SLEEP or IDLE Mode, various methods are available to wake the device up. One of these is a high to low transition of any of the Port A pins. Single or multiple pins on Port A can be setup to have this function.

Timer Modules – TM

One of the most fundamental functions in any microcontroller devices is the ability to control and measure time. To implement time related functions the device includes several Timer Modules, generally abbreviated to the name TM. The TMs are multi-purpose timing units and serve to provide operations such as Timer/Counter, Input Capture, Compare Match Output and Single Pulse Output as well as being the functional unit for the generation of PWM signals. Each of the TMs has two interrupts. The addition of input and output pins for each TM ensures that users are provided with timing units with a wide and flexible range of features.

The common features of the different TM types are described here with more detailed information provided in the individual Compact and Standard Type TM sections.

Introduction

The device contains three TMs and each individual TM can be categorised as a certain type, namely Compact Type TM or Standard Type TM. Although similar in nature, the different TM types vary in their feature complexity. The common features to all of the Compact and Standard type TMs will be described in this section and the detailed operation regarding each of the TM types will be described in separate sections. The main features and differences between the two types of TMs are summarised in the accompanying table.

TM Function	CTM	STM
Timer/Counter	√	√
Input Capture	—	√
Compare Match Output	√	√
PWM Output	√	√
Single Pulse Output	—	√
PWM Alignment	Edge	Edge
PWM Adjustment Period & Duty	Duty or Period	Duty or Period

TM Function Summary

CTM	STM
10-bit CTM0 10-bit CTM1	16-bit STM

TM Name/Type Reference

TM Operation

The different types of TM offer a diverse range of functions, from simple timing operations to PWM signal generation. The key to understanding how the TM operates is to see it in terms of a free running count-up counter whose value is then compared with the value of pre-programmed internal comparators. When the free running count-up counter has the same value as the pre-programmed comparator, known as a compare match situation, a TM interrupt signal will be generated which can clear the counter and perhaps also change the condition of the TM output pin. The internal TM counter is driven by a user selectable clock source, which can be an internal clock or an external pin.

TM Clock Source

The clock source which drives the main counter in each TM can originate from various sources. The selection of the required clock source is implemented using the xTnCK2~xTnCK0 bits in the xTMn control registers, where “x” stands for C or S type TM and “n” stands for the specific TM serial number. For the STM there is no serial number “n” in the relevant pins, registers and control bits since there is only one STM in the device. The clock source can be a ratio of the system clock,

f_{SYS} , or the internal high clock, f_H , the f_{SUB} clock source or the external xTCKn pin. The xTCKn pin clock source is used to allow an external signal to drive the TM as an external clock source for event counting.

TM Interrupts

The Compact or Standard type TM has two internal interrupt, one for each of the internal comparator A or comparator P, which generate a TM interrupt when a compare match condition occurs. When a TM interrupt is generated, it can be used to clear the counter and also to change the state of the TM output pin.

TM External Pins

Each of the TMs, irrespective of what type, has an TM input pin, with the label xTCKn. The xTMn input pin, xTCKn, is essentially a clock source for the xTMn and is selected using the xTnCK2~xTnCK0 bits in the xTMnC0 register. This external TM input pin allows an external clock source to drive the internal TM. The xTCKn input pin can be chosen to have either a rising or falling active edge. The STCK pin is also used as the external trigger input pin in single pulse output mode for the STM.

The Standard type TM has another input pin, STPI, which is the capture input whose active edge can be a rising edge, a falling edge or both rising and falling edges and the active edge transition type is selected using the STIO1~STIO0 bits in the STMC1 register.

The TMs each has two output pins, xTPn and xTPnB. When the TM is in the Compare Match Output Mode, these pins can be controlled by the TM to switch to a high or low level or to toggle when a compare match situation occurs. The external xTPn and xTPnB pins are also the pins where the TM generates the PWM output waveform.

As the TM input and output pins are pin-shared with other functions, the TM input and output functions must first be setup using the relevant pin-shared function selection bits described in the Pin-shared Function section.

CTM		STM	
Input	Output	Input	Output
CTCK0 CTCK1	CTP0, CTP0B CTP1, CTP1B	STCK, STPI	STP, STPB

TM External Pins

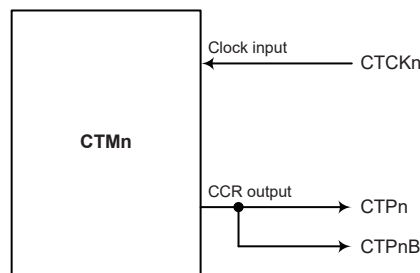

CTMn Function Pin Block Diagram (n=0~1)

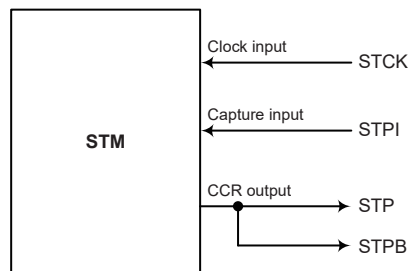

STM Function Pin Block Diagram

Programming Considerations

The TM Counter Registers and the Capture/Compare CCRA register, all have a low and high byte structure. The high bytes can be directly accessed, but as the low bytes can only be accessed via an internal 8-bit buffer, reading or writing to these register pairs must be carried out in a specific way. The important point to note is that data transfer to and from the 8-bit buffer and its related low byte only takes place when a write or read operation to its corresponding high byte is executed.

As the CCRA register is implemented in the way shown in the following diagram and accessing these register pairs is carried out in a specific way as described above, it is recommended to use the “MOV” instruction to access the CCRA low byte registers, named xTMnAL, using the following access procedures. Accessing the CCRA low byte registers without following these access procedures will result in unpredictable values.

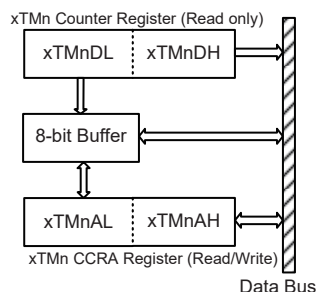

The following steps show the read and write procedures:

- Writing Data to CCRA
 - ♦ Step 1. Write data to Low Byte xTMnAL
 - Note that here data is only written to the 8-bit buffer.
 - ♦ Step 2. Write data to High Byte xTMnAH
 - Here data is written directly to the high byte registers and simultaneously data is latched from the 8-bit buffer to the Low Byte registers.
- Reading Data from the Counter Registers and CCRA
 - ♦ Step 1. Read data from the High Byte xTMnDH, xTMnAH
 - Here data is read directly from the High Byte registers and simultaneously data is latched from the Low Byte register into the 8-bit buffer.
 - ♦ Step 2. Read data from the Low Byte xTMnDL, xTMnAL
 - This step reads data from the 8-bit buffer.

Compact Type TM – CTM

The Compact TM type contains three operating modes, which are Compare Match Output, Timer/Event Counter and PWM Output modes. The Compact TM can also be controlled with an external input pin and can drive two external output pins.

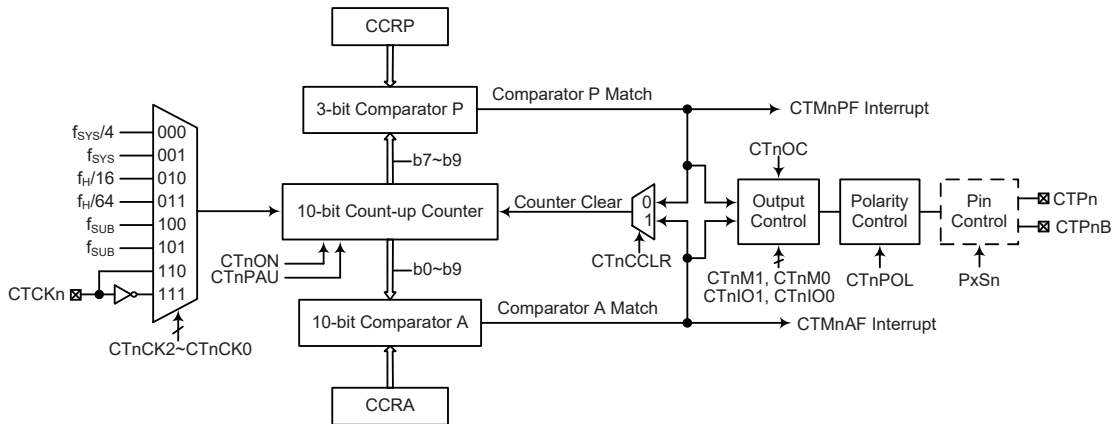

Note: The CTPnB is the inverted output of the CTPn.

Compact Type TM Block Diagram (n=0~1)

Compact TM Operation

At its core is a 10-bit count-up counter which is driven by a user selectable internal or external clock source. There are also two internal comparators with the names, Comparator A and Comparator P. These comparators will compare the value in the counter with CCRP and CCRA registers. The CCRP is three bits wide whose value is compared with the highest three bits in the counter while the CCRA is the ten bits and therefore compares with all counter bits.

The only way of changing the value of the 10-bit counter using the application program, is to clear the counter by changing the CTnON bit from low to high. The counter will also be cleared automatically by a counter overflow or a compare match with one of its associated comparators. When these conditions occur, a CTMn interrupt signal will also usually be generated. The Compact Type TM can operate in a number of different operational modes, can be driven by different clock sources including an input pin and can also control two output pins. All operating setup conditions are selected using relevant internal registers.

Compact Type TM Register Description

Overall operation of the Compact type TM is controlled using several registers. A read only register pair exists to store the internal counter 10-bit value, while a read/write register pair exists to store the internal 10-bit CCRA value. The remaining two registers are control registers which setup the different operating and control modes as well as the three CCRP bits.

Register Name	Bit							
	7	6	5	4	3	2	1	0
CTMnC0	CTnPAU	CTnCK2	CTnCK1	CTnCK0	CTnON	CTnRP2	CTnRP1	CTnRP0
CTMnC1	CTnM1	CTnM0	CTnIO1	CTnIO0	CTnOC	CTnPOL	CTnDPX	CTnCCLR
CTMnDL	D7	D6	D5	D4	D3	D2	D1	D0
CTMnDH	—	—	—	—	—	—	D9	D8
CTMnAL	D7	D6	D5	D4	D3	D2	D1	D0
CTMnAH	—	—	—	—	—	—	D9	D8

10-bit Compact Type TM Register List (n=0~1)

• **CTMnC0 Register**

Bit	7	6	5	4	3	2	1	0
Name	CTnPAU	CTnCK2	CTnCK1	CTnCK0	CTnON	CTnRP2	CTnRP1	CTnRP0
R/W	R/W	R/W	R/W	R/W	R/W	R/W	R/W	R/W
POR	0	0	0	0	0	0	0	0

Bit 7 **CTnPAU**: CTMn Counter Pause Control

0: Run
1: Pause

The counter can be paused by setting this bit high. Clearing the bit to zero restores normal counter operation. When in a Pause condition the CTMn will remain powered up and continue to consume power. The counter will retain its residual value when this bit changes from low to high and resume counting from this value when the bit changes to a low value again.

Bit 6~4 **CTnCK2~CTnCK0**: Select CTMn Counter clock

000: $f_{SYS}/4$
001: f_{SYS}
010: $f_H/16$
011: $f_H/64$
100: f_{SUB}
101: f_{SUB}
110: CTCKn rising edge clock
111: CTCKn falling edge clock

These three bits are used to select the clock source for the CTMn. The external pin clock source can be chosen to be active on the rising or falling edge. The clock source f_{SYS} is the system clock, while f_H and f_{SUB} are other internal clocks, the details of which can be found in the oscillator section.

Bit 3 **CTnON**: CTMn Counter On/Off Control

0: Off
1: On

This bit controls the overall on/off function of the CTMn. Setting the bit high enables the counter to run, clearing the bit disables the CTMn. Clearing this bit to zero will stop the counter from counting and turn off the CTMn which will reduce its power consumption. When the bit changes state from low to high the internal counter value will be reset to zero, however when the bit changes from high to low, the internal counter will retain its residual value until the bit returns high again.

If the CTMn is in the Compare Match Output Mode or the PWM Output Mode then the CTMn output pin will be reset to its initial condition, as specified by the CTnOC bit, when the CTnON bit changes from low to high.

Bit 2~0 **CTnRP2~CTnRP0**: CTMn CCRP 3-bit register, compared with the CTMn Counter bit 9~bit 7

Comparator P Match Period
000: 1024 CTMn clocks
001: 128 CTMn clocks
010: 256 CTMn clocks
011: 384 CTMn clocks
100: 512 CTMn clocks
101: 640 CTMn clocks
110: 768 CTMn clocks
111: 896 CTMn clocks

These three bits are used to setup the value on the internal CCRP 3-bit register, which are then compared with the internal counter's highest three bits. The result of this comparison can be selected to clear the internal counter if the CTnCCLR bit is set to zero. Setting the CTnCCLR bit to zero ensures that a compare match with the CCRP values will reset the internal counter. As the CCRP bits are only compared with the

highest three counter bits, the compare values exist in 128 clock cycle multiples. Clearing all three bits to zero is in effect allowing the counter to overflow at its maximum value.

• **CTMnC1 Register**

Bit	7	6	5	4	3	2	1	0
Name	CTnM1	CTnM0	CTnIO1	CTnIO0	CTnOC	CTnPOL	CTnDPX	CTnCCLR
R/W	R/W	R/W	R/W	R/W	R/W	R/W	R/W	R/W
POR	0	0	0	0	0	0	0	0

Bit 7~6 **CTnM1~CTnM0**: Select CTMn Operating Mode

- 00: Compare Match Output Mode
- 01: Undefined
- 10: PWM Output Mode
- 11: Timer/Counter Mode

These bits setup the required operating mode for the CTMn. To ensure reliable operation the CTMn should be switched off before any changes are made to the CTnM1 and CTnM0 bits. In the Timer/Counter Mode, the CTMn output pin state is undefined.

Bit 5~4 **CTnIO1~CTnIO0**: Select CTPn function

Compare Match Output Mode

- 00: No change
- 01: Output low
- 10: Output high
- 11: Toggle output

PWM Output Mode

- 00: PWM Output inactive state
- 01: PWM Output active state
- 10: PWM output
- 11: Undefined

Timer/counter Mode

Unused

These two bits are used to determine how the CTMn external pin changes state when a certain condition is reached. The function that these bits select depends upon in which mode the CTMn is running.

In the Compare Match Output Mode, the CTnIO1 and CTnIO0 bits determine how the CTMn output pin changes state when a compare match occurs from the Comparator A. The CTMn output pin can be setup to switch high, switch low or to toggle its present state when a compare match occurs from the Comparator A. When the bits are both zero, then no change will take place on the output. The initial value of the CTMn output pin should be setup using the CTnOC bit in the CTMnC1 register. Note that the output level requested by the CTnIO1 and CTnIO0 bits must be different from the initial value setup using the CTnOC bit otherwise no change will occur on the CTMn output pin when a compare match occurs. After the CTMn output pin changes state it can be reset to its initial level by changing the level of the CTnON bit from low to high.

In the PWM Output Mode, the CTnIO1 and CTnIO0 bits determine how the CTMn output pin changes state when a certain compare match condition occurs. The PWM output function is modified by changing these two bits. It is necessary to only change the values of the CTnIO1 and CTnIO0 bits only after the CTMn has been switched off. Unpredictable PWM outputs will occur if the CTnIO1 and CTnIO0 bits are changed when The CTMn is running.

Bit 3 **CTnOC**: CTPn Output control bit

Compare Match Output Mode

- 0: Initial low
- 1: Initial high

PWM Output Mode

- 0: Active low
- 1: Active high

This is the output control bit for the CTMn output pin. Its operation depends upon whether CTMn is being used in the Compare Match Output Mode or in the PWM Output Mode. It has no effect if the CTMn is in the Timer/Counter Mode. In the Compare Match Output Mode it determines the logic level of the CTMn output pin before a compare match occurs. In the PWM Output Mode it determines if the PWM signal is active high or active low.

Bit 2 **CTnPOL**: CTPn Output polarity Control

- 0: Non-invert
- 1: Invert

This bit controls the polarity of the CTPn output pin. When the bit is set high the CTMn output pin will be inverted and not inverted when the bit is zero. It has no effect if the CTMn is in the Timer/Counter Mode.

Bit 1 **CTnDPX**: CTMn PWM period/duty Control

- 0: CCRP - period; CCRA - duty
- 1: CCRP - duty; CCRA - period

This bit, determines which of the CCRA and CCRP registers are used for period and duty control of the PWM waveform.

Bit 0 **CTnCCLR**: Select CTMn Counter clear condition

- 0: CTMn Comparatror P match
- 1: CTMn Comparatror A match

This bit is used to select the method which clears the counter. Remember that the Compact TM contains two comparators, Comparator A and Comparator P, either of which can be selected to clear the internal counter. With the CTnCCLR bit set high, the counter will be cleared when a compare match occurs from the Comparator A. When the bit is low, the counter will be cleared when a compare match occurs from the Comparator P or with a counter overflow. A counter overflow clearing method can only be implemented if the CCRP bits are all cleared to zero. The CTnCCLR bit is not used in the PWM Output Mode.

• **CTMnDL Register**

Bit	7	6	5	4	3	2	1	0
Name	D7	D6	D5	D4	D3	D2	D1	D0
R/W	R	R	R	R	R	R	R	R
POR	0	0	0	0	0	0	0	0

Bit 7~0 **D7~D0**: CTMn Counter Low Byte Register bit 7~bit 0
CTMn 10-bit Counter bit 7~bit 0

• **CTMnDH Register**

Bit	7	6	5	4	3	2	1	0
Name	—	—	—	—	—	—	D9	D8
R/W	—	—	—	—	—	—	R	R
POR	—	—	—	—	—	—	0	0

Bit 7~2 Unimplemented, read as “0”

Bit 1~0 **D9~D8**: CTMn Counter High Byte Register bit 1~bit 0
CTMn 10-bit Counter bit 9~bit 8

• **CTMnAL Register**

Bit	7	6	5	4	3	2	1	0
Name	D7	D6	D5	D4	D3	D2	D1	D0
R/W	R/W	R/W	R/W	R/W	R/W	R/W	R/W	R/W
POR	0	0	0	0	0	0	0	0

Bit 7~0 **D7~D0:** CTMn CCRA Low Byte Register bit 7~bit 0
 CTMn 10-bit CCRA bit 7~bit 0

• **CTMnAH Register**

Bit	7	6	5	4	3	2	1	0
Name	—	—	—	—	—	—	D9	D8
R/W	—	—	—	—	—	—	R/W	R/W
POR	—	—	—	—	—	—	0	0

Bit 7~2 Unimplemented, read as “0”
 Bit 1~0 **D9~D8:** CTMn CCRA High Byte Register bit 1~bit 0
 CTMn 10-bit CCRA bit 9~bit 8

Compact Type TM Operating Modes

The Compact Type TM can operate in one of three operating modes, Compare Match Output Mode, PWM Output Mode or Timer/Counter Mode. The operating mode is selected using the CTnM1 and CTnM0 bits in the CTMnC1 register.

Compare Match Output Mode

To select this mode, bits CTnM1 and CTnM0 in the CTMnC1 register, should be set to 00 respectively. In this mode once the counter is enabled and running it can be cleared by three methods. These are a counter overflow, a compare match from Comparator A and a compare match from Comparator P. When the CTnCCLR bit is low, there are two ways in which the counter can be cleared. One is when a compare match from Comparator P, the other is when the CCRP bits are all zero which allows the counter to overflow. Here both CTMnAF and CTMnPF interrupt request flags for Comparator A and Comparator P respectively, will both be generated.

If the CTnCCLR bit in the CTMnC1 register is high then the counter will be cleared when a compare match occurs from Comparator A. However, here only the CTMnAF interrupt request flag will be generated even if the value of the CCRP bits is less than that of the CCRA registers. Therefore when CTnCCLR is high no CTMnPF interrupt request flag will be generated.

If the CCRA bits are all zero, the counter will overflow when its reaches its maximum 10-bit, 3FF Hex, value, however here the CTMnAF interrupt request flag will not be generated.

As the name of the mode suggests, after a comparison is made, the CTMn output pin will change state. The CTMn output pin condition however only changes state when a CTMnAF interrupt request flag is generated after a compare match occurs from Comparator A. The CTMnPF interrupt request flag, generated from a compare match occurs from Comparator P, will have no effect on the CTMn output pin. The way in which the CTMn output pin changes state are determined by the condition of the CTnIO1 and CTnIO0 bits in the CTMnC1 register. The CTMn output pin can be selected using the CTnIO1 and CTnIO0 bits to go high, to go low or to toggle from its present condition when a compare match occurs from Comparator A. The initial condition of the CTMn output pin, which is setup after the CTON bit changes from low to high, is setup using the CTnOC bit. Note that if the CTnIO1 and CTnIO0 bits are zero then no pin change will take place.

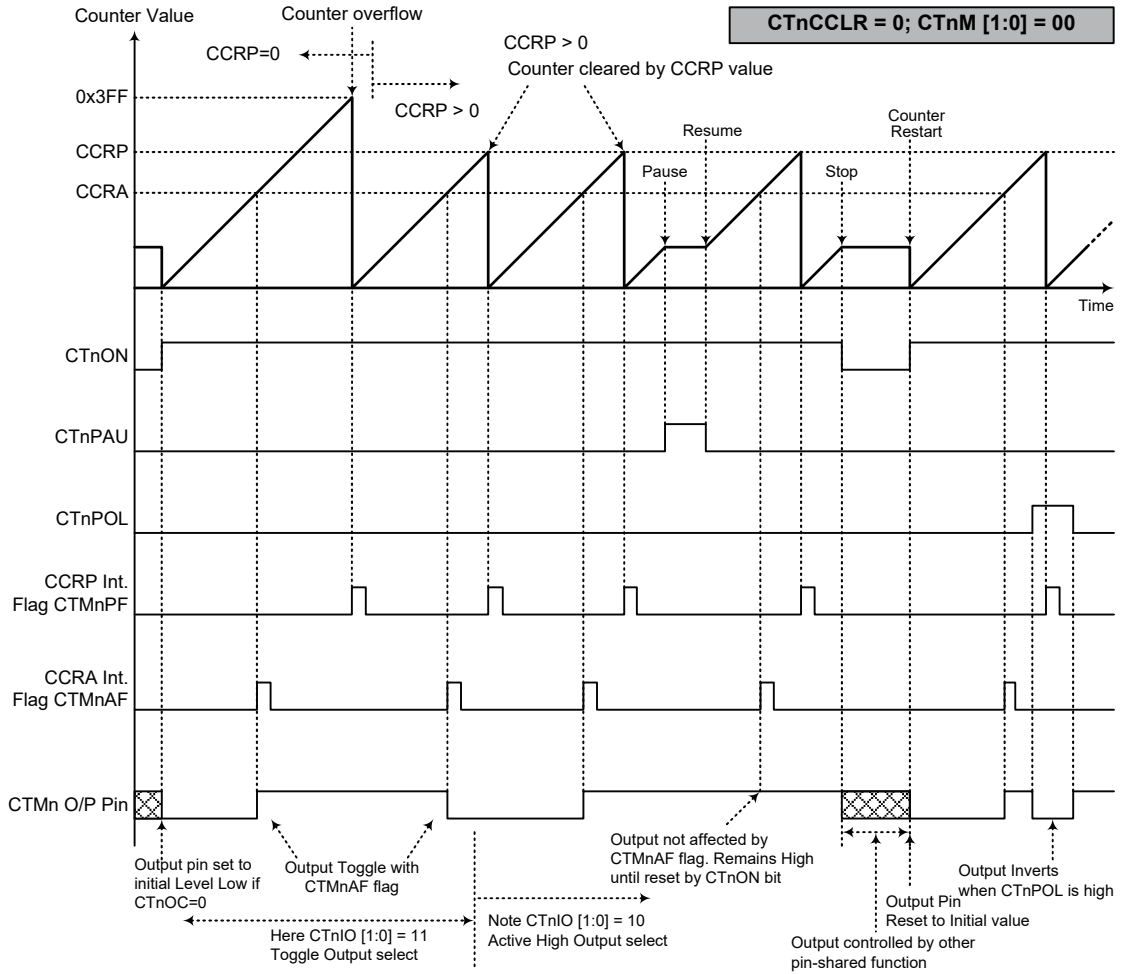

- Note: 1. With CTnCCLR=0, a Comparator P match will clear the counter
 2. The CTMn output pin controlled only by the CTMnAF flag
 3. The output pin reset to initial state by a CTnON bit rising edge

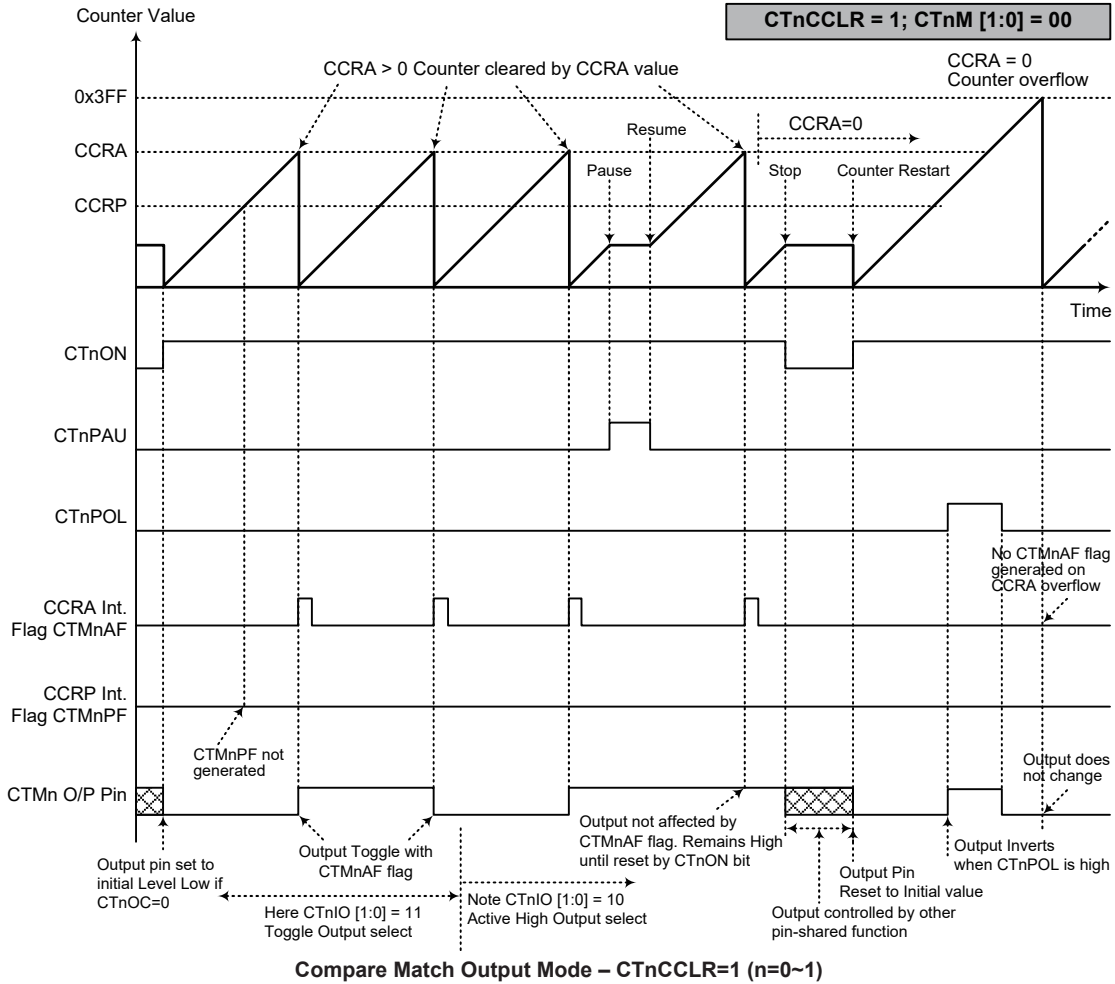

- Note: 1. With CTnCCR=1, a Comparator A match will clear the counter
2. The CTMn output pin controlled only by the CTMnAF flag
3. The output pin reset to initial state by a CTnON rising edge
4. The CTMnPF flags is not generated when CTnCCR=1

Timer/Counter Mode

To select this mode, bits CTnM1 and CTnM0 in the CTMnC1 register should be set to 11 respectively. The Timer/Counter Mode operates in an identical way to the Compare Match Output Mode generating the same interrupt flags. The exception is that in the Timer/Counter Mode the CTMn output pin is not used. Therefore the above description and Timing Diagrams for the Compare Match Output Mode can be used to understand its function. As the CTMn output pin is not used in this mode, the pin can be used as a normal I/O pin or other pin-shared function.

PWM Output Mode

To select this mode, bits CTnM1 and CTnM0 in the CTMnC1 register should be set to 10 respectively. The PWM function within the CTMn is useful for applications which require functions such as motor control, heating control, illumination control etc. By providing a signal of fixed frequency but of varying duty cycle on the CTMn output pin, a square wave AC waveform can be generated with varying equivalent DC RMS values.

As both the period and duty cycle of the PWM waveform can be controlled, the choice of generated waveform is extremely flexible. In the PWM Output Mode, the CTnCCLR bit has no effect on the PWM operation. Both of the CCRA and CCRP registers are used to generate the PWM waveform, one register is used to clear the internal counter and thus control the PWM waveform frequency, while the other one is used to control the duty cycle. Which register is used to control either frequency or duty cycle is determined using the CTnDPX bit in the CTMnC1 register. The PWM waveform frequency and duty cycle can therefore be controlled by the values in the CCRA and CCRP registers.

An interrupt flag, one for each of the CCRA and CCRP, will be generated when a compare match occurs from either Comparator A or Comparator P. The CTnOC bit in the CTMnC1 register is used to select the required polarity of the PWM waveform while the two CTnIO1 and CTnIO0 bits are used to enable the PWM output or to force the CTMn output pin to a fixed high or low level. The CTnPOL bit is used to reverse the polarity of the PWM output waveform.

• **10-bit CTMn, PWM Output Mode, Edge-aligned Mode, CTnDPX=0**

CCRP	1~7	0
Period	CCRP×128	1024
Duty	CCRA	

If $f_{SYS}=8\text{MHz}$, CTMn clock source is $f_{SYS}/4$, CCRP=2, CCRA=128,

The CTMn PWM output frequency= $(f_{SYS}/4)/(2\times 128)=f_{SYS}/1024=7.812\text{kHz}$, duty= $128/(2\times 128)=50\%$.

If the Duty value defined by the CCRA register is equal to or greater than the Period value, then the PWM output duty is 100%.

• **10-bit CTMn, PWM Output Mode, Edge-aligned Mode, CTnDPX=1**

CCRP	1~7	0
Period	CCRA	
Duty	CCRP×128	1024

The PWM output period is determined by the CCRA register value together with the CTMn clock while the PWM duty cycle is defined by the CCRP register value.

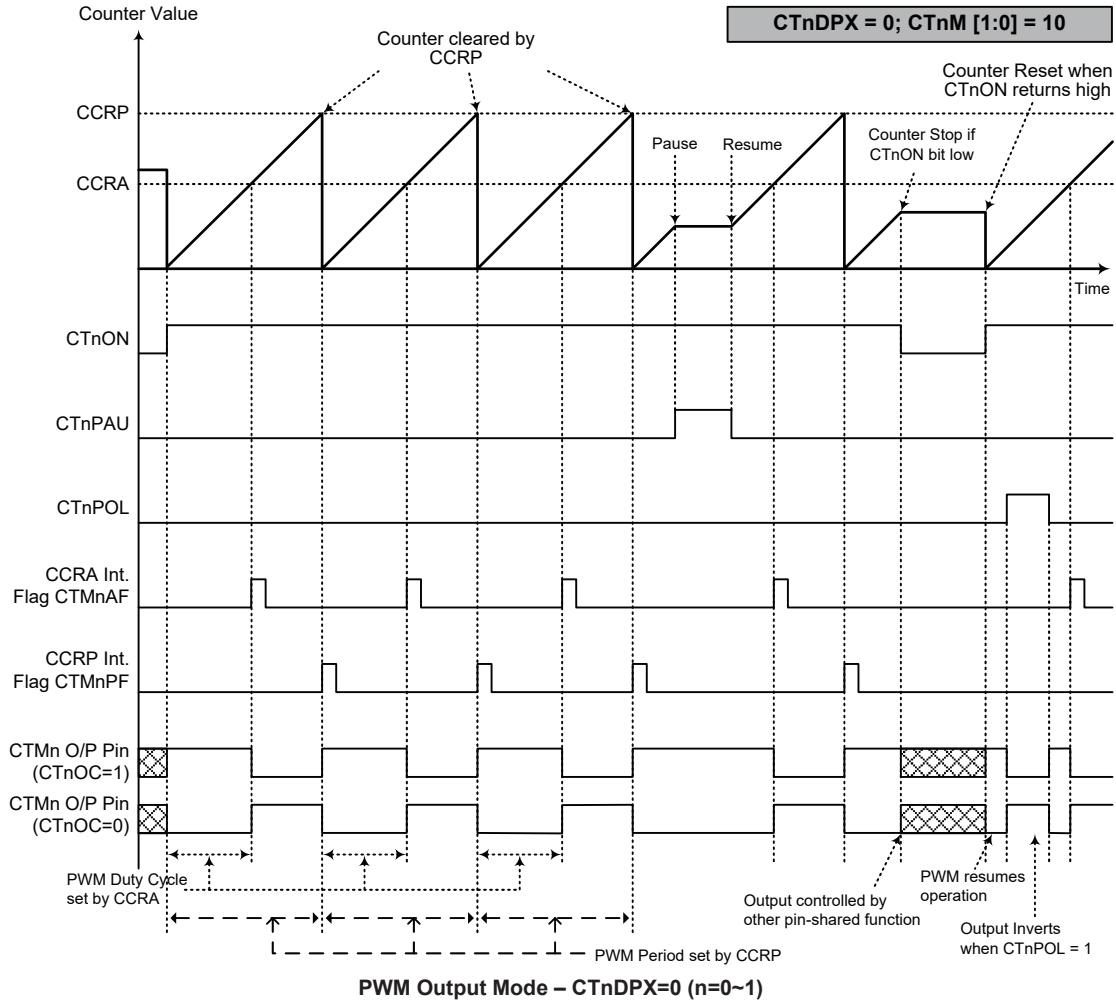

- Note: 1. Here CTnDPX=0 – Counter cleared by CCRP
 2. A counter clear sets PWM Period
 3. The internal PWM function continues running even when CTnIO[1:0]=00 or 01
 4. The CTnCCLR bit has no influence on PWM operation

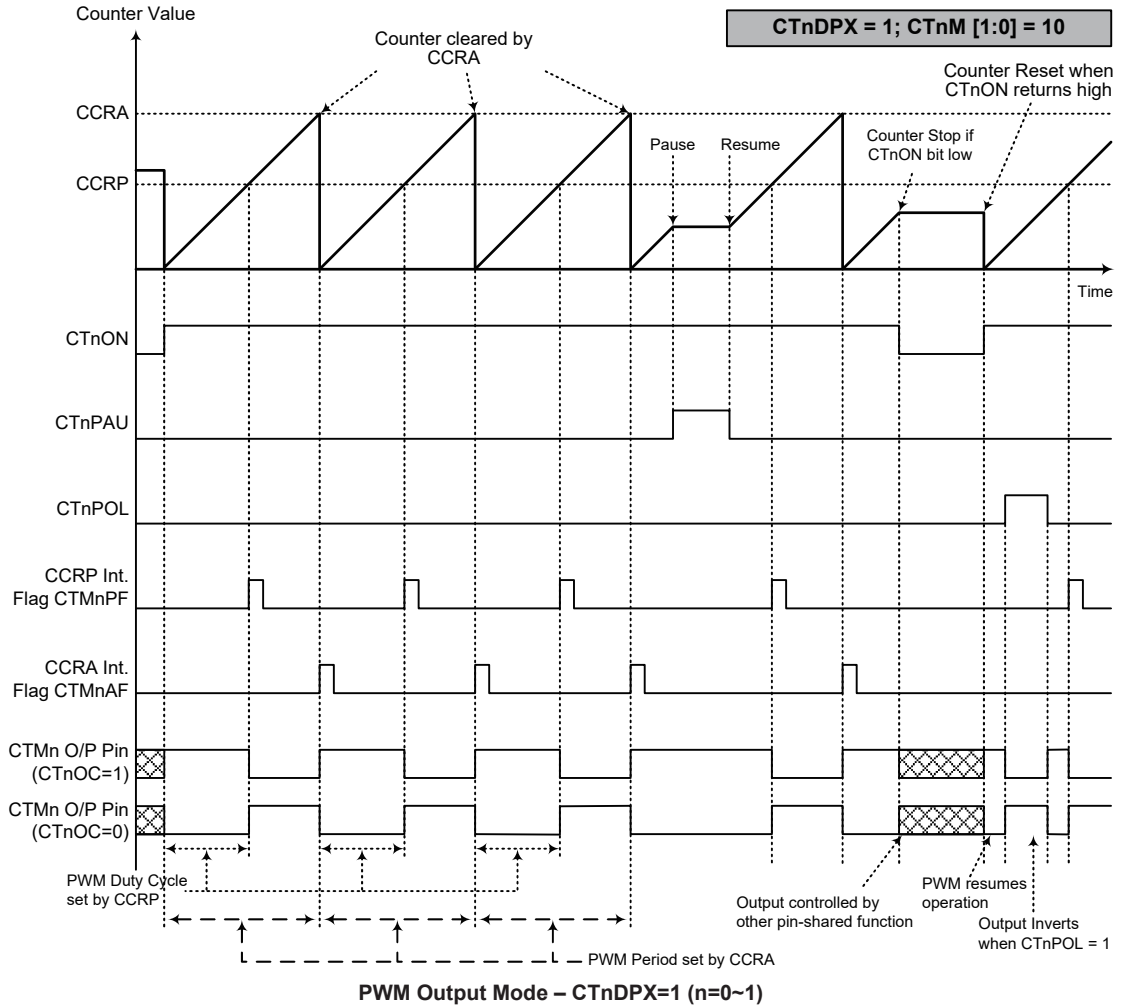

- Note: 1. Here CTnDPX=1 – Counter cleared by CCRA
 2. A counter clear sets PWM Period
 3. The internal PWM function continues even when CTnIO[1:0]=00 or 01
 4. The CTnCCLR bit has no influence on PWM operation

Standard Type TM – STM

The Standard Type TM contains five operating modes, which are Compare Match Output, Timer/Event Counter, Capture Input, Single Pulse Output and PWM Output modes. The Standard TM can also be controlled with two external input pins and can drive two external output pins.

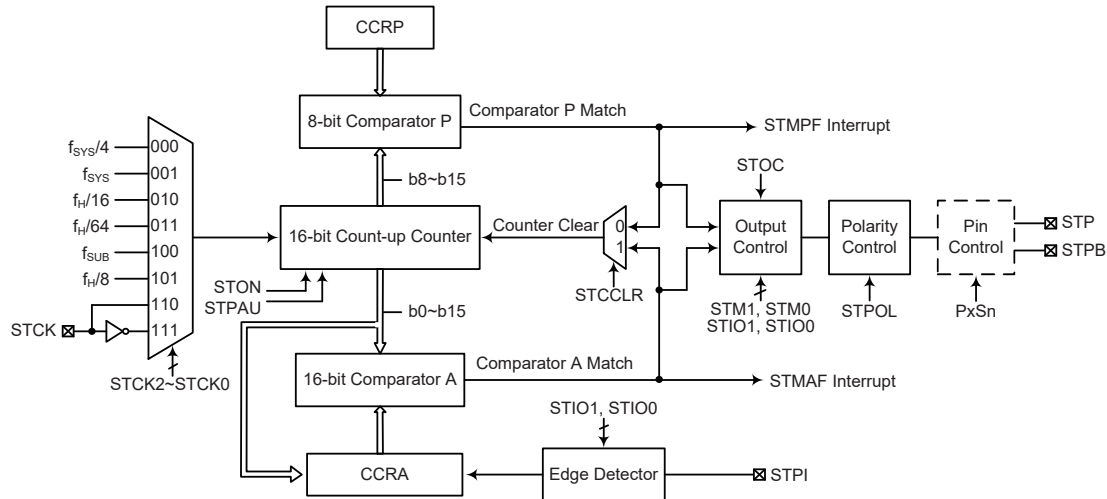

Note: The STPB is the inverted output of the STP.

Standard Type TM Block Diagram

Standard TM Operation

The size of Standard TM is 16-bit wide and its core is a 16-bit count-up counter which is driven by a user selectable internal or external clock source. There are also two internal comparators with the names, Comparator A and Comparator P. These comparators will compare the value in the counter with CCRP and CCRA registers. The CCRP comparator is 8-bit wide whose value is compared the with highest 8 bits in the counter while the CCRA is the sixteen bits and therefore compares all counter bits.

The only way of changing the value of the 16-bit counter using the application program, is to clear the counter by changing the STON bit from low to high. The counter will also be cleared automatically by a counter overflow or a compare match with one of its associated comparators. When these conditions occur, a STM interrupt signal will also usually be generated. The Standard Type TM can operate in a number of different operational modes, can be driven by different clock sources including an input pin and can also control two output pins. All operating setup conditions are selected using relevant internal registers.

Standard Type TM Register Description

Overall operation of the Standard TM is controlled using a series of registers. A read only register pair exists to store the internal counter 16-bit value, while a read/write register pair exists to store the internal 16-bit CCRA value. The STMRP register is used to store the 8-bit CCRP value. The remaining two registers are control registers which setup the different operating and control modes.

Register Name	Bit							
	7	6	5	4	3	2	1	0
STMC0	STPAU	STCK2	STCK1	STCK0	STON	—	—	—
STMC1	STM1	STM0	STIO1	STIO0	STOC	STPOL	STDPX	STCCLR
STMDL	D7	D6	D5	D4	D3	D2	D1	D0
STMDH	D15	D14	D13	D12	D11	D10	D9	D8
STMAL	D7	D6	D5	D4	D3	D2	D1	D0
STMAH	D15	D14	D13	D12	D11	D10	D9	D8
STMRP	D7	D6	D5	D4	D3	D2	D1	D0

16-bit Standard Type TM Register List

• **STMC0 Register**

Bit	7	6	5	4	3	2	1	0
Name	STPAU	STCK2	STCK1	STCK0	STON	—	—	—
R/W	R/W	R/W	R/W	R/W	R/W	—	—	—
POR	0	0	0	0	0	—	—	—

- Bit 7 STPAU:** STM Counter Pause control
 0: Run
 1: Pause
 The counter can be paused by setting this bit high. Clearing the bit to zero restores normal counter operation. When in a Pause condition the STM will remain powered up and continue to consume power. The counter will retain its residual value when this bit changes from low to high and resume counting from this value when the bit changes to a low value again.
- Bit 6~4 STCK2~STCK0:** Select STM Counter clock
 000: $f_{SYS}/4$
 001: f_{SYS}
 010: $f_H/16$
 011: $f_H/64$
 100: f_{SUB}
 101: f_{SUB}
 110: STCK rising edge clock
 111: STCK falling edge clock
 These three bits are used to select the clock source for the STM. The external pin clock source can be chosen to be active on the rising or falling edge. The clock source f_{SYS} is the system clock, while f_H and f_{SUB} are other internal clocks, the details of which can be found in the oscillator section.
- Bit 3 STON:** STM Counter On/Off control
 0: Off
 1: On
 This bit controls the overall on/off function of the STM. Setting the bit high enables the counter to run while clearing the bit disables the STM. Clearing this bit to zero will stop the counter from counting and turn off the STM which will reduce its power consumption. When the bit changes state from low to high the internal counter value will be reset to zero, however when the bit changes from high to low, the internal counter will retain its residual value until the bit returns high again. If the STM is in the Compare Match Output Mode, the PWM Output Mode or the Single Pulse Output Mode then the STM output pin will be reset to its initial condition, as specified by the STOC bit, when the STON bit changes from low to high.
- Bit 2~0** Unimplemented, read as “0”

• **STMC1 Register**

Bit	7	6	5	4	3	2	1	0
Name	STM1	STM0	STIO1	STIO0	STOC	STPOL	STDPX	STCCLR
R/W	R/W	R/W	R/W	R/W	R/W	R/W	R/W	R/W
POR	0	0	0	0	0	0	0	0

Bit 7~6 **STM1~STM0**: Select STM Operating Mode
 00: Compare Match Output Mode
 01: Capture Input Mode
 10: PWM Output Mode or Single Pulse Output Mode
 11: Timer/Counter Mode
 These bits setup the required operating mode for the STM. To ensure reliable operation the STM should be switched off before any changes are made to the STM1 and STM0 bits. In the Timer/Counter Mode, the STM output pin state is undefined.

Bit 5~4 **STIO1~STIO0**: Select STM external pin STP function
 Compare Match Output Mode
 00: No change
 01: Output low
 10: Output high
 11: Toggle output
 PWM Output Mode/Single Pulse Output Mode
 00: PWM output inactive state
 01: PWM output active state
 10: PWM output
 11: Single Pulse Output
 Capture Input Mode
 00: Input capture at rising edge of STPI
 01: Input capture at falling edge of STPI
 10: Input capture at rising/falling edge of STPI
 11: Input capture disabled
 Timer/Counter Mode
 Unused

These two bits are used to determine how the STM external pin changes state when a certain condition is reached. The function that these bits select depends upon in which mode the STM is running.

In the Compare Match Output Mode, the STIO1 and STIO0 bits determine how the STM output pin changes state when a compare match occurs from the Comparator A. The TM output pin can be setup to switch high, switch low or to toggle its present state when a compare match occurs from the Comparator A. When the bits are both zero, then no change will take place on the output. The initial value of the STM output pin should be setup using the STOC bit in the STMC1 register. Note that the output level requested by the STIO1 and STIO0 bits must be different from the initial value setup using the STOC bit otherwise no change will occur on the STM output pin when a compare match occurs. After the STM output pin changes state, it can be reset to its initial level by changing the level of the STON bit from low to high.

In the PWM Output Mode, the STIO1 and STIO0 bits determine how the STM output pin changes state when a certain compare match condition occurs. The PWM output function is modified by changing these two bits. It is necessary to only change the values of the STIO1 and STIO0 bits only after the STM has been switched off. Unpredictable PWM outputs will occur if the STIO1 and STIO0 bits are changed when the STM is running.

Bit 3 **STOC**: STM STP Output control
 Compare Match Output Mode
 0: Initial low
 1: Initial high

PWM Output Mode/Single Pulse Output Mode

- 0: Active low
- 1: Active high

This is the output control bit for the STM output pin. Its operation depends upon whether STM is being used in the Compare Match Output Mode or in the PWM Output Mode/Single Pulse Output Mode. It has no effect if the STM is in the Timer/Counter Mode. In the Compare Match Output Mode it determines the logic level of the STM output pin before a compare match occurs. In the PWM output Mode it determines if the PWM signal is active high or active low. In the Single Pulse Output Mode it determines the logic level of the STM output pin when the STON bit changes from low to high.

Bit 2 **STPOL**: STM STP Output polarity control

- 0: Non-invert
- 1: Invert

This bit controls the polarity of the STP output pin. When the bit is set high the STM output pin will be inverted and not inverted when the bit is zero. It has no effect if the STM is in the Timer/Counter Mode.

Bit 1 **STDPX**: STM PWM duty/period control

- 0: CCRP – period; CCRA – duty
- 1: CCRP – duty; CCRA – period

This bit determines which of the CCRA and CCRP registers are used for period and duty control of the PWM waveform.

Bit 0 **STCCLR**: STM Counter Clear condition selection

- 0: Comparator P match
- 1: Comparator A match

This bit is used to select the method which clears the counter. Remember that the Standard TM contains two comparators, Comparator A and Comparator P, either of which can be selected to clear the internal counter. With the STCCLR bit set high, the counter will be cleared when a compare match occurs from the Comparator A. When the bit is low, the counter will be cleared when a compare match occurs from the Comparator P or with a counter overflow. A counter overflow clearing method can only be implemented if the CCRP bits are all cleared to zero. The STCCLR bit is not used in the PWM Output, Single Pulse Output or Capture Input Mode.

• **STMDL Register**

Bit	7	6	5	4	3	2	1	0
Name	D7	D6	D5	D4	D3	D2	D1	D0
R/W	R	R	R	R	R	R	R	R
POR	0	0	0	0	0	0	0	0

Bit 7~0 **D7~D0**: STM Counter Low Byte Register bit 7~bit 0
STM 16-bit Counter bit 7~bit 0

• **STMDH Register**

Bit	7	6	5	4	3	2	1	0
Name	D15	D14	D13	D12	D11	D10	D9	D8
R/W	R	R	R	R	R	R	R	R
POR	0	0	0	0	0	0	0	0

Bit 7~0 **D15~D8**: STM Counter High Byte Register bit 7~bit 0
STM 16-bit Counter bit 15~bit 8

• **STMAL Register**

Bit	7	6	5	4	3	2	1	0
Name	D7	D6	D5	D4	D3	D2	D1	D0
R/W	R/W	R/W	R/W	R/W	R/W	R/W	R/W	R/W
POR	0	0	0	0	0	0	0	0

Bit 7~0 **D7~D0**: STM CCRA Low Byte Register bit 7~bit 0
 STM 16-bit CCRA bit 7~bit 0

• **STMAH Register**

Bit	7	6	5	4	3	2	1	0
Name	D15	D14	D13	D12	D11	D10	D9	D8
R/W	R/W	R/W	R/W	R/W	R/W	R/W	R/W	R/W
POR	0	0	0	0	0	0	0	0

Bit 7~0 **D15~D8**: STM CCRA High Byte Register bit 7~bit 0
 STM 16-bit CCRA bit 15~bit 8

• **STMRP Register**

Bit	7	6	5	4	3	2	1	0
Name	D7	D6	D5	D4	D3	D2	D1	D0
R/W	R/W	R/W	R/W	R/W	R/W	R/W	R/W	R/W
POR	0	0	0	0	0	0	0	0

Bit 7~0 **D7~D0**: STM CCRP 8-bit register, compared with the STM counter bit 15~bit 8
 Comparator P match period=
 0: 65536 STM clocks
 1~255: (1~255)×256 STM clocks

These eight bits are used to setup the value on the internal CCRP 8-bit register, which are then compared with the internal counter's highest eight bits. The result of this comparison can be selected to clear the internal counter if the STCCLR bit is set to zero. Setting the STCCLR bit to zero ensures that a compare match with the CCRP values will reset the internal counter. As the CCRP bits are only compared with the highest eight counter bits, the compare values exist in 256 clock cycle multiples. Clearing all eight bits to zero is in effect allowing the counter to overflow at its maximum value.

Standard Type TM Operation Modes

The Standard Type TM can operate in one of five operating modes, Compare Match Output Mode, PWM Output Mode, Single Pulse Output Mode, Capture Input Mode or Timer/Counter Mode. The operating mode is selected using the STM1 and STM0 bits in the STMC1 register.

Compare Match Output Mode

To select this mode, bits STM1 and STM0 in the STMC1 register, should be set to 00 respectively. In this mode once the counter is enabled and running it can be cleared by three methods. These are a counter overflow, a compare match from Comparator A and a compare match from Comparator P. When the STCCLR bit is low, there are two ways in which the counter can be cleared. One is when a compare match from Comparator P, the other is when the CCRP bits are all zero which allows the counter to overflow. Here both STMAF and STMPF interrupt request flags for Comparator A and Comparator P respectively, will both be generated.

If the STCCLR bit in the STMC1 register is high then the counter will be cleared when a compare match occurs from Comparator A. However, here only the STMAF interrupt request flag will be generated even if the value of the CCRP bits is less than that of the CCRA registers. Therefore when

STCCLR is high no STMPF interrupt request flag will be generated. In the Compare Match Output Mode, the CCRA can not be set to "0".

If the CCRA bits are all zero, the counter will overflow when it reaches its maximum 16-bit, FFFF Hex, value, however here the STMAF interrupt request flag, generated from a compare match occurs from Comparator P, will have no effect on the STM output pin.

As the name of the mode suggests, after a comparison is made, the STM output pin, will change state. The STM output pin condition however only changes state when a STMAF interrupt request flag is generated after a compare match occurs from Comparator A. The STMPF interrupt request flag, generated from a compare match occurs from Comparator P, will have no effect on the STM output pin. The way in which the STM output pin changes state are determined by the condition of the STIO1 and STIO0 bits in the STMC1 register. The STM output pin can be selected using the STIO1 and STIO0 bits to go high, to go low or to toggle from its present condition when a compare match occurs from Comparator A. The initial condition of the STM output pin, which is setup after the STON bit changes from low to high, is setup using the STOC bit. Note that if the STIO1 and STIO0 bits are zero then no pin change will take place.

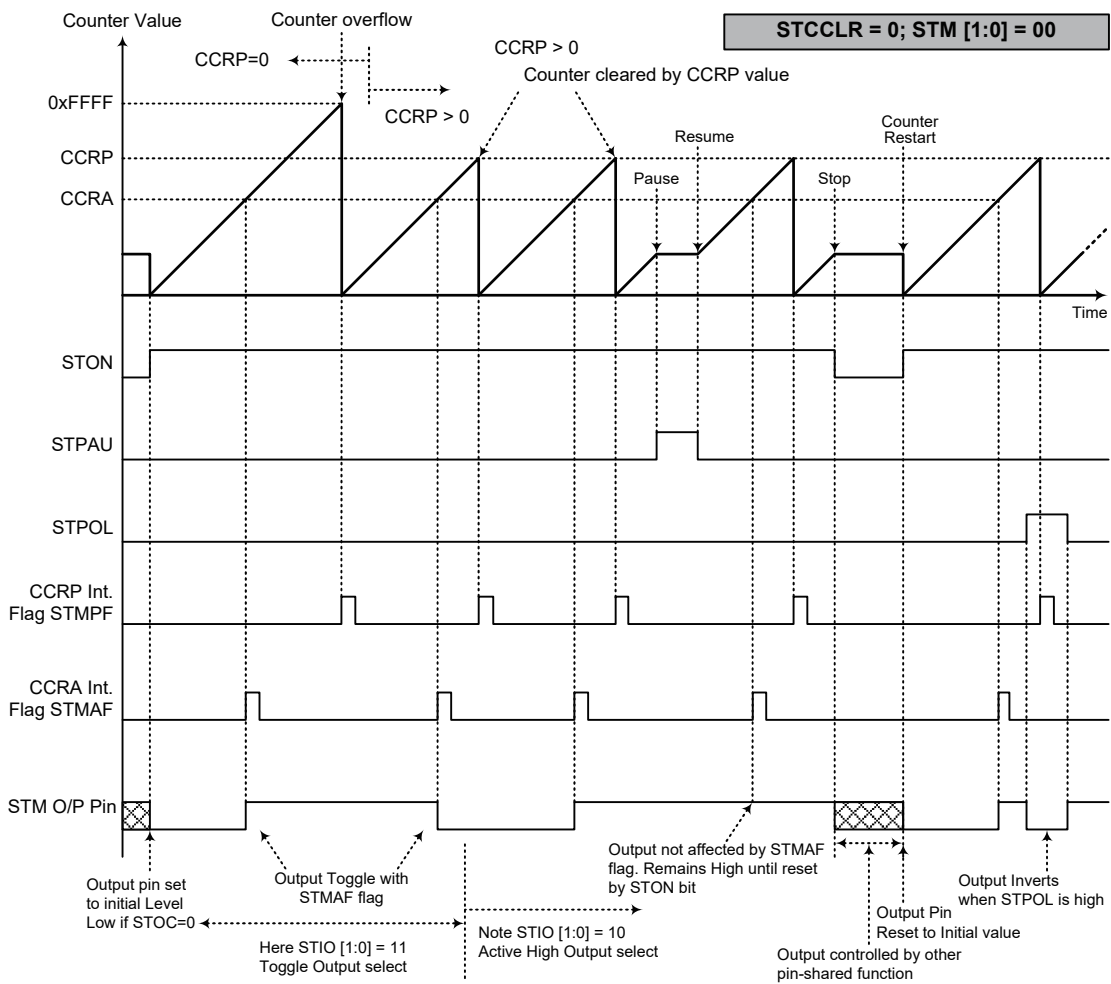

- Note: 1. With STCCLR=0 a Comparator P match will clear the counter
 2. The STM output pin is controlled only by the STMAF flag
 3. The output pin is reset to its initial state by a STON bit rising edge

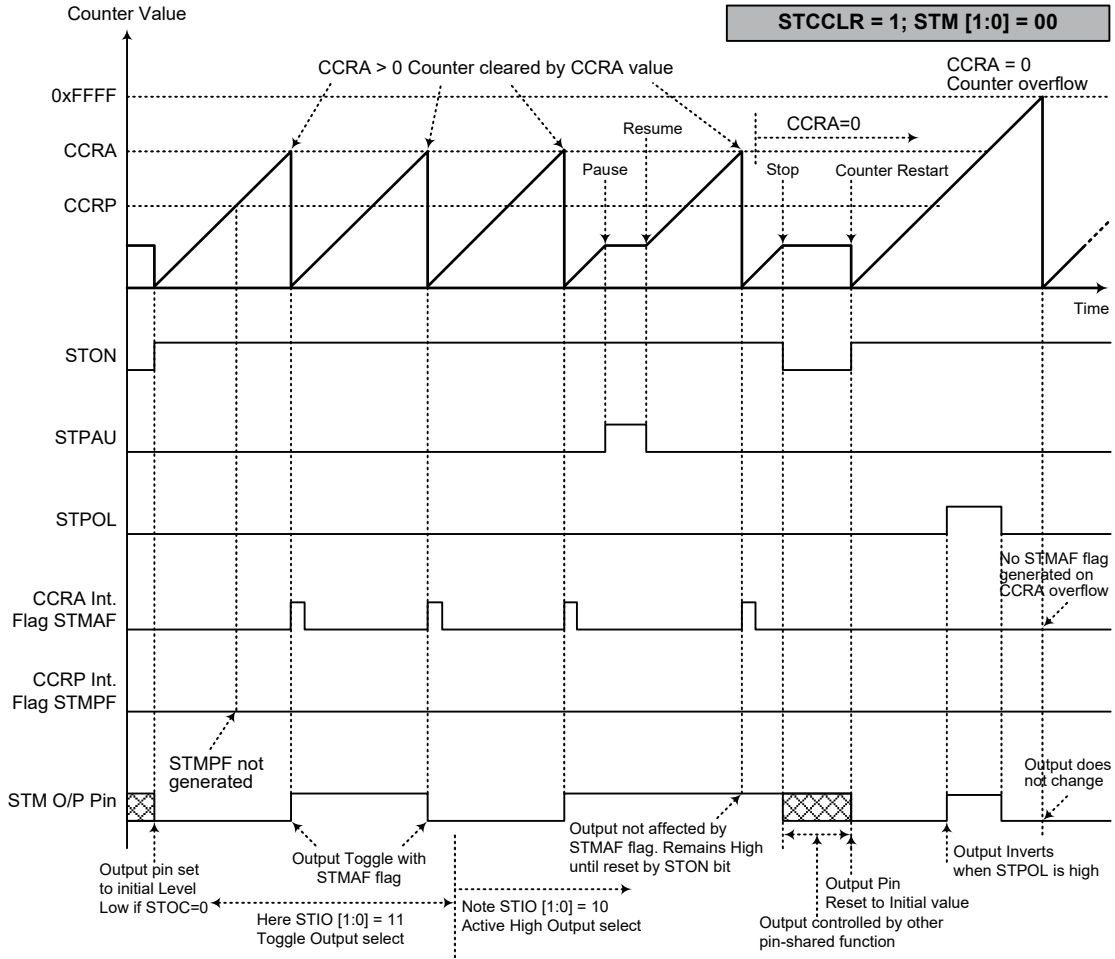

Compare Match Output Mode – STCCLR=1

- Note: 1. With STCCLR=1 a Comparator A match will clear the counter
2. The STM output pin is controlled only by the STMAF flag
3. The output pin is reset to its initial state by a STON bit rising edge
4. A STMPF flag is not generated when STCCLR=1

Timer/Counter Mode

To select this mode, bits STM1 and STM0 in the STMC1 register should be set to 11 respectively. The Timer/Counter Mode operates in an identical way to the Compare Match Output Mode generating the same interrupt flags. The exception is that in the Timer/Counter Mode the STM output pin is not used. Therefore the above description and Timing Diagrams for the Compare Match Output Mode can be used to understand its function. As the STM output pin is not used in this mode, the pin can be used as a normal I/O pin or other pin-shared function.

PWM Output Mode

To select this mode, bits STM1 and STM0 in the STMC1 register should be set to 10 respectively and also the STIO1 and STIO0 bits should be set to 10 respectively. The PWM function within the STM is useful for applications which require functions such as motor control, heating control, illumination control etc. By providing a signal of fixed frequency but of varying duty cycle on the STM output pin, a square wave AC waveform can be generated with varying equivalent DC RMS values.

As both the period and duty cycle of the PWM waveform can be controlled, the choice of generated waveform is extremely flexible. In the PWM Output Mode, the STCCLR bit has no effect as the PWM period. Both of the CCRA and CCRP registers are used to generate the PWM waveform, one register is used to clear the internal counter and thus control the PWM waveform frequency, while the other one is used to control the duty cycle. Which register is used to control either frequency or duty cycle is determined using the STDPX bit in the STMC1 register. The PWM waveform frequency and duty cycle can therefore be controlled by the values in the CCRA and CCRP registers.

An interrupt flag, one for each of the CCRA and CCRP, will be generated when a compare match occurs from either Comparator A or Comparator P. The STOC bit in the STMC1 register is used to select the required polarity of the PWM waveform while the two STIO1 and STIO0 bits are used to enable the PWM output or to force the STM output pin to a fixed high or low level. The STPOL bit is used to reverse the polarity of the PWM output waveform.

• **16-bit STM, PWM Output Mode, Edge-aligned Mode, STDPX=0**

CCRP	1~255	0
Period	CCRP×256	65536
Duty	CCRA	

If $f_{SYS}=8\text{MHz}$, STM clock source is $f_{SYS}/4$, CCRP=2 and CCRA=128,

The STM PWM output frequency= $(f_{SYS}/4)/(2\times 256)=f_{SYS}/2048=4\text{kHz}$, duty= $128/(2\times 256)=25\%$.

If the Duty value defined by the CCRA register is equal to or greater than the Period value, then the PWM output duty is 100%.

• **16-bit STM, PWM Output Mode, Edge-aligned Mode, STDPX=1**

CCRP	1~255	0
Period	CCRA	
Duty	CCRP×256	65536

The PWM output period is determined by the CCRA register value together with the STM clock while the PWM duty cycle is defined by the CCRP register value except when the CCRP value is equal to 0.

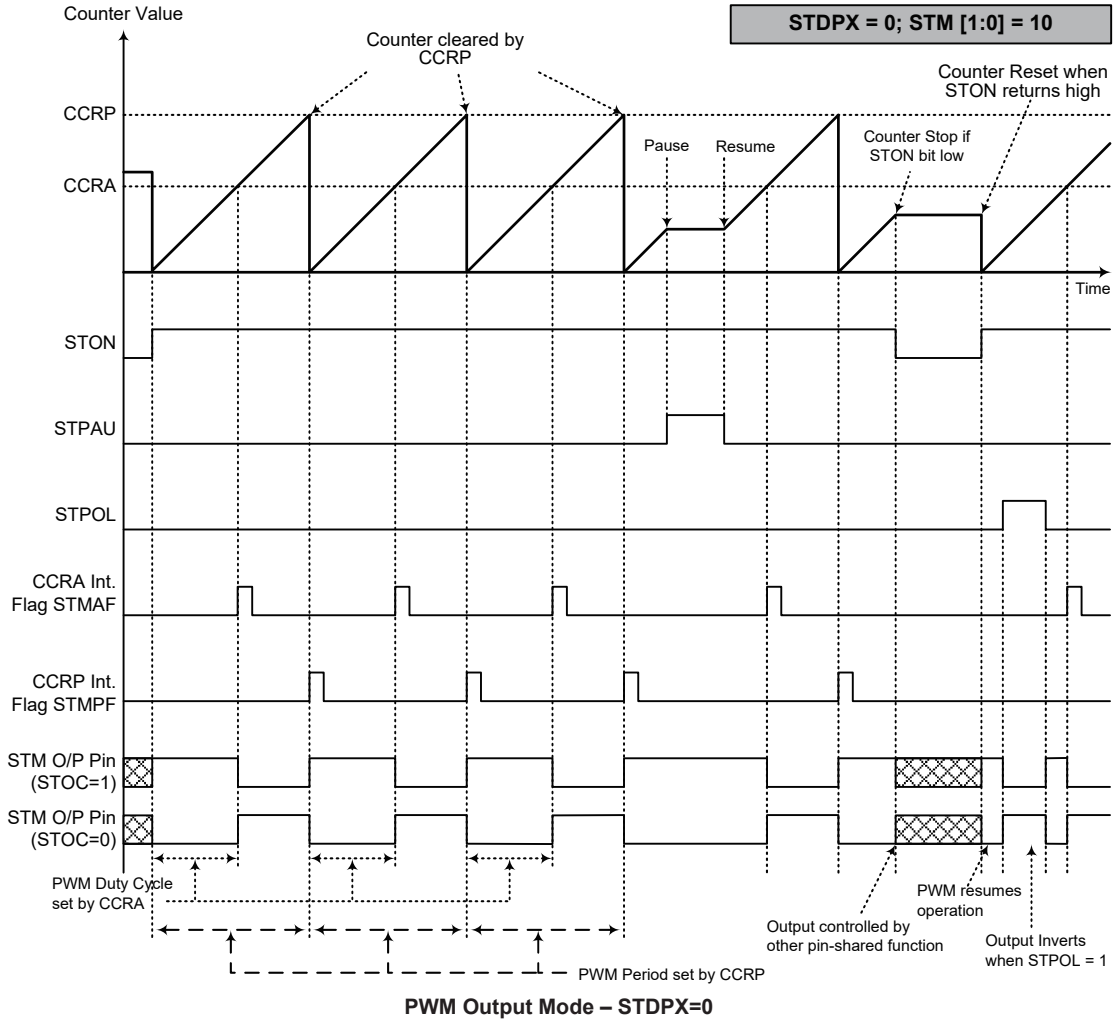

- Note: 1. Here STDPX=0 – Counter cleared by CCRP
 2. A counter clear sets the PWM Period
 3. The internal PWM function continues running even when STIO [1:0]=00 or 01
 4. The STCCLR bit has no influence on PWM operation

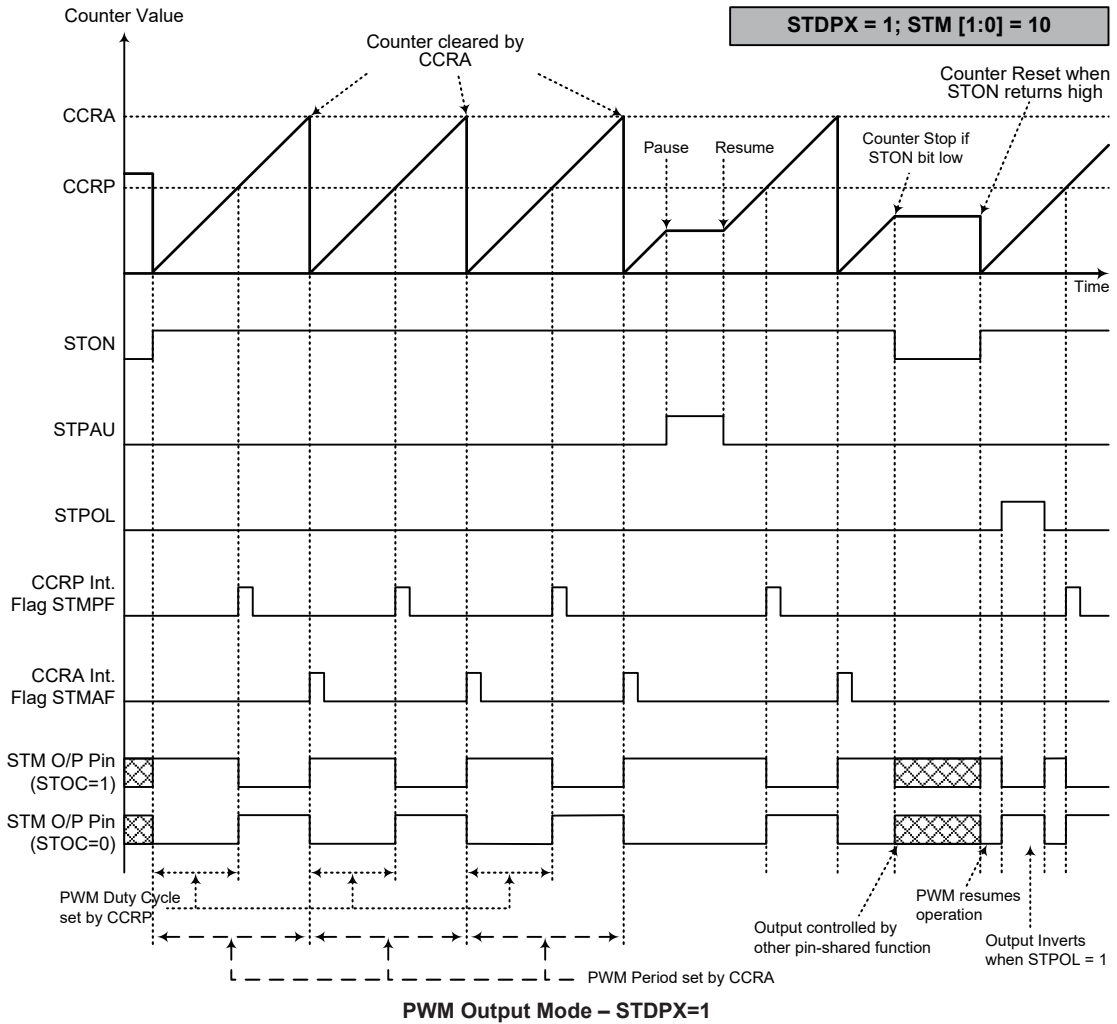

- Note: 1. Here STDPX=1 – Counter cleared by CCRA
 2. A counter clear sets the PWM Period
 3. The internal PWM function continues even when STIO [1:0]=00 or 01
 4. The STCCLR bit has no influence on PWM operation

Single Pulse Output Mode

To select this mode, bits STM1 and STM0 in the STMC1 register should be set to 10 respectively and also the STIO1 and STIO0 bits should be set to 11 respectively. The Single Pulse Output Mode, as the name suggests, will generate a single shot pulse on the STM output pin.

The trigger for the pulse output leading edge is a low to high transition of the STON bit, which can be implemented using the application program. However in the Single Pulse Output Mode, the STON bit can also be made to automatically change from low to high using the external STCK pin, which will in turn initiate the Single Pulse output. When the STON bit transitions to a high level, the counter will start running and the pulse leading edge will be generated. The STON bit should remain high when the pulse is in its active state. The generated pulse trailing edge will be generated when the STON bit is cleared to zero, which can be implemented using the application program or when a compare match occurs from Comparator A.

However a compare match from Comparator A will also automatically clear the STON bit and thus generate the Single Pulse output trailing edge. In this way the CCRA value can be used to control the pulse width. A compare match from Comparator A will also generate a STM interrupt. The counter can only be reset back to zero when the STON bit changes from low to high when the counter restarts. In the Single Pulse Output Mode CCRP is not used. The STCCLR and STDPX bits are not used in this Mode.

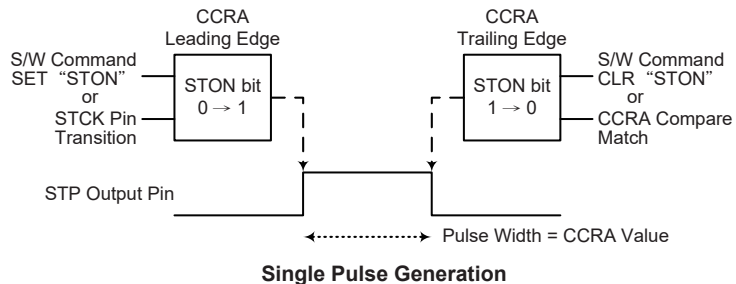

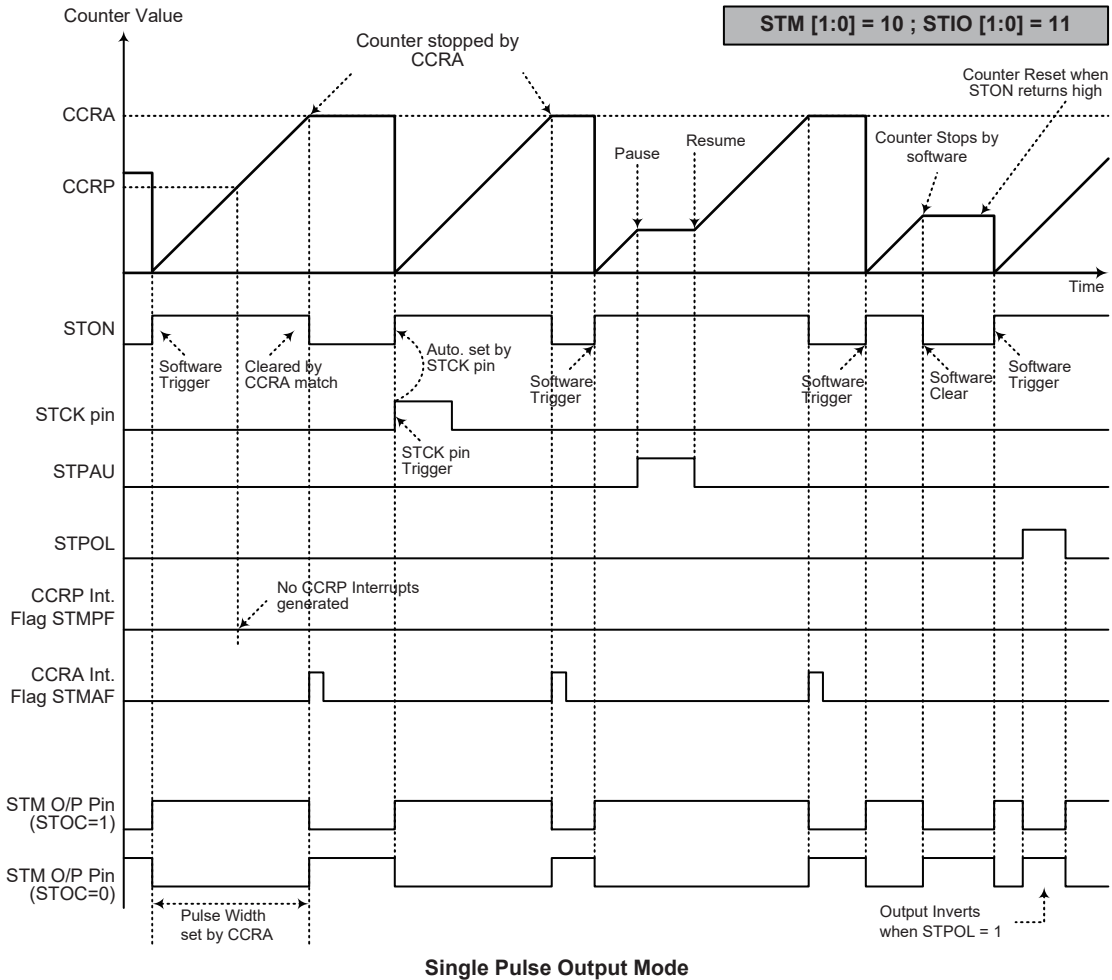

- Note: 1. Counter stopped by CCRA
 2. CCRP is not used
 3. The pulse triggered by the STCK pin or by setting the STON bit high
 4. A STCK pin active edge will automatically set the STON bit high
 5. In the Single Pulse Output Mode, STIO [1:0] must be set to "11" and can not be changed

Capture Input Mode

To select this mode bits STM1 and STM0 in the STMC1 register should be set to 01 respectively. This mode enables external signals to capture and store the present value of the internal counter and can therefore be used for applications such as pulse width measurements. The external signal is supplied on the STPI pin, whose active edge can be a rising edge, a falling edge or both rising and falling edges; the active edge transition type is selected using the STIO1 and STIO0 bits in the STMC1 register. The counter is started when the STON bit changes from low to high which is initiated using the application program.

When the required edge transition appears on the STPI pin the present value in the counter will be latched into the CCRA registers and a STM interrupt generated. Irrespective of what events occur on the STPI pin the counter will continue to free run until the STON bit changes from high to low. When a CCRP compare match occurs the counter will reset back to zero; in this way the CCRP value can be used to control the maximum counter value. When a CCRP compare match occurs

from Comparator P, a STM interrupt will also be generated. Counting the number of overflow interrupt signals from the CCRP can be a useful method in measuring long pulse widths. The STIO1 and STIO0 bits can select the active trigger edge on the STPI pin to be a rising edge, falling edge or both edge types. If the STIO1 and STIO0 bits are both set high, then no capture operation will take place irrespective of what happens on the STPI pin, however it must be noted that the counter will continue to run. The STCCLR and STDPX bits are not used in this Mode.

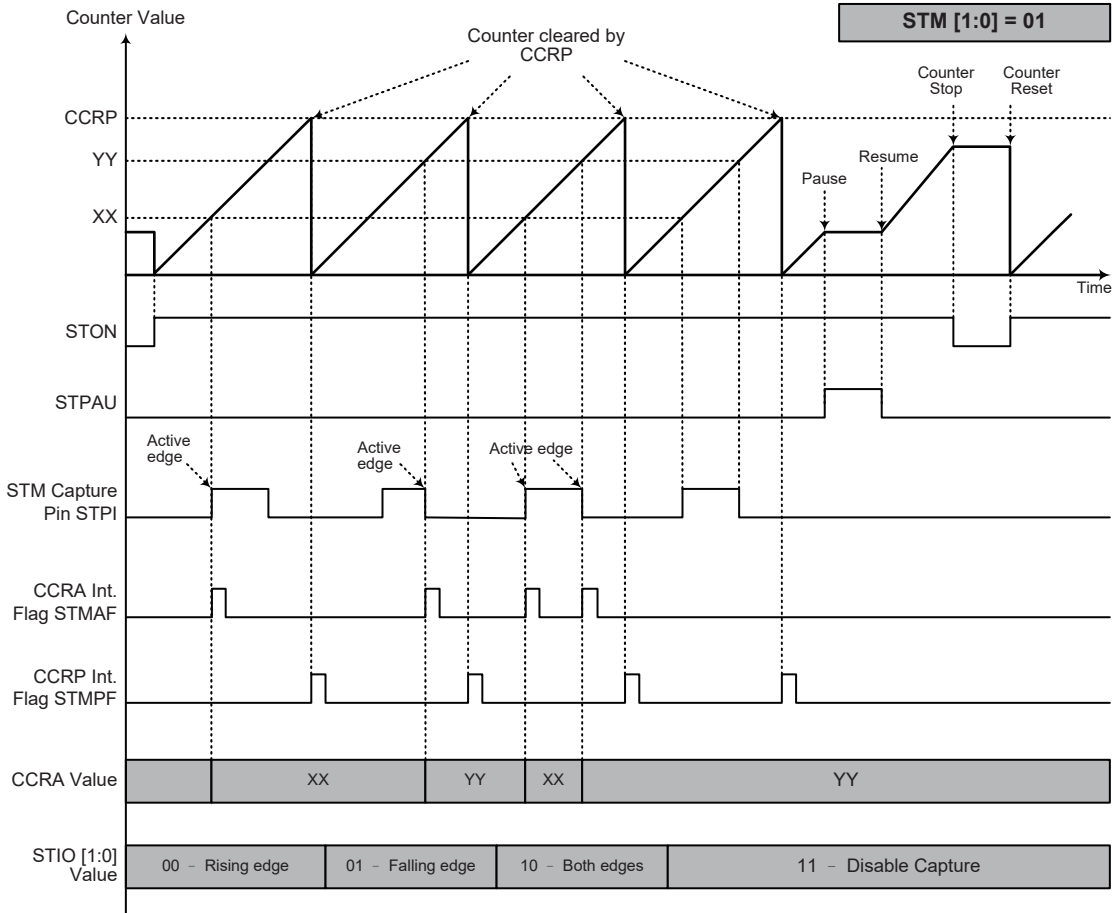

Capture Input Mode

- Note: 1. STM [1:0]=01 and active edge set by the STIO [1:0] bits
 2. A STM Capture input pin active edge transfers the counter value to CCRA
 3. STCCLR bit not used
 4. No output function – STOC and STPOL bits are not used
 5. CCRP determines the counter value and the counter has a maximum count value when CCRP is equal to zero

Analog to Digital Converter

The need to interface to real world analog signals is a common requirement for many electronic systems. However, to properly process these signals by a microcontroller, they must first be converted into digital signals by A/D Converters. By integrating the A/D conversion electronic circuitry into the microcontroller, the need for external components is reduced significantly with the corresponding follow-on benefits of lower costs and reduced component space requirements.

A/D Converter Overview

This device contains a multi-channel analog to digital converter which can directly interface to external analog signals, such as that from sensors or other control signals and convert these signals directly into a 12-bit digital value. The external or internal analog signal to be converted is determined by the SAINS2~SAINS0 bits together with the SACS3~SACS0 bits. When the external analog signal is to be converted, the corresponding pin-shared control bits should first be properly configured and then desired external channel input should be selected using the SAINS2~SAINS0 and SACS3~SACS0 bits. Note that when the internal analog signal is to be converted, the pin-shared control bits should also be properly configured except the SAINS and SACS bit fields. More detailed information about the A/D Converter input signal is described in the “A/D Converter Control Registers” and “A/D Converter Input Signals” sections respectively.

External Input Channels	A/D Channel Select Bits
7: AN1~AN7	SAINS2~SAINS0, SACS3~SACS0

The accompanying block diagram shows the internal structure of the A/D Converter with its associated registers and control bits.

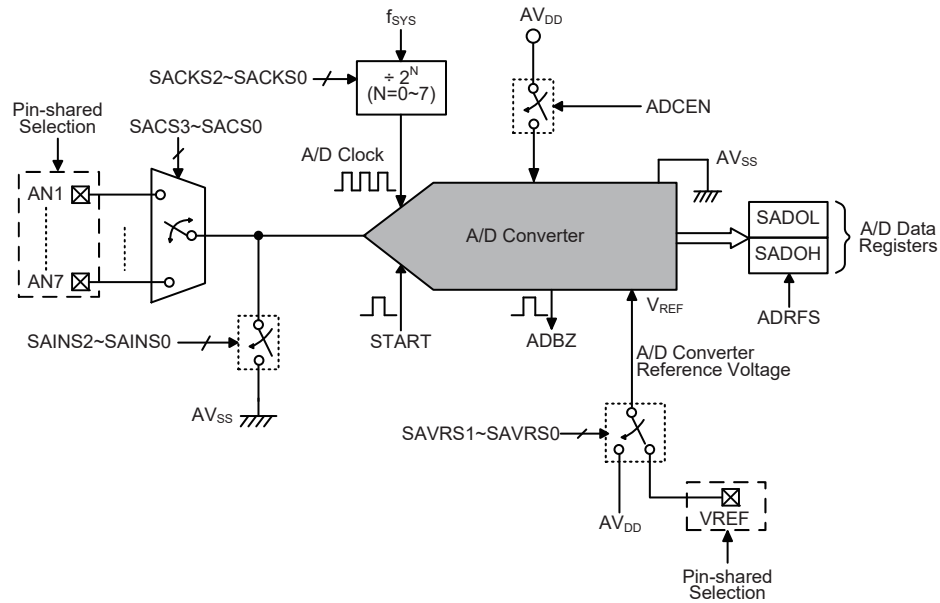

A/D Converter with Temperature Sensor Structure

A/D Converter Register Description

Overall operation of the A/D Converter with temperature sensor is controlled using five registers. A read only register pair exists to store the A/D Converter data 12-bit value. Two registers, SADC0 and SADC1 are control registers which setup the operating and control function of the A/D Converter. The SADC2 register is the control register which control independent reference bandgap enable/disable.

Register Name	Bit							
	7	6	5	4	3	2	1	0
SADOL (ADRFS=0)	D3	D2	D1	D0	—	—	—	—
SADOH (ADRFS=0)	D11	D10	D9	D8	D7	D6	D5	D4
SADOL (ADRFS=1)	D7	D6	D5	D4	D3	D2	D1	D0
SADOH (ADRFS=1)	—	—	—	—	D11	D10	D9	D8
SADC0	START	ADBZ	ADCEN	ADRFS	SACS3	SACS2	SACS1	SACS0
SADC1	SAINS2	SAINS1	SAINS0	SAVRS1	SAVRS0	SACKS2	SACKS1	SACKS0
SADC2	VBGREN	—	—	—	—	—	—	—

A/D Converter Register List

A/D Converter Data Registers – SADOL, SADOH

As this device contains an internal 12-bit A/D Converter, it requires two data registers to store the converted value. These are a high byte register, known as SADOH, and a low byte register, known as SADOL. After the conversion process takes place, these registers can be directly read by the microcontroller to obtain the digitised conversion value. As only 12 bits of the 16-bit register space is utilised, the format in which the data is stored is controlled by the ADRFS bit in the SADC0 register as shown in the accompanying table. D0~D11 are the A/D conversion result data bits. Any unused bits will be read as zero. Note that A/D data registers contents will be unchanged if the A/D Converter is disabled.

ADRFS	SADOH								SADOL							
	7	6	5	4	3	2	1	0	7	6	5	4	3	2	1	0
0	D11	D10	D9	D8	D7	D6	D5	D4	D3	D2	D1	D0	0	0	0	0
1	0	0	0	0	D11	D10	D9	D8	D7	D6	D5	D4	D3	D2	D1	D0

A/D Data Registers

A/D Converter Control Registers – SADC0, SADC1, SADC2

To control the function and operation of the A/D Converter, two control registers known as SADC0 and SADC1 are provided. These 8-bit registers define functions such as the selection of which analog channel is connected to the internal A/D Converter, the digitised data format, the A/D clock source as well as controlling the start function and monitoring the A/D Converter busy status. As the device contains only one actual analog to digital converter hardware circuit, each of the external or internal analog signal inputs must be routed to the converter. The SACS3~SACS0 bits in the SADC0 register are used to determine which external channel input is selected to be converted. The SAINS2~SAINS0 bits in the SADC1 register are used to determine that the analog signal to be converted comes from the internal analog signal or external analog channel input.

The relevant pin-shared function selection bits determine which pins on I/O Ports are used as analog inputs for the A/D Converter input and which pins are not to be used as the A/D Converter input. When the pin is selected to be an A/D input, its original function whether it is an I/O or other pin-shared function will be removed. In addition, any internal pull-high resistor connected to the pin will be automatically removed if the pin is selected to be an A/D Converter input.

• **SADC0 Register**

Bit	7	6	5	4	3	2	1	0
Name	START	ADBZ	ADCEN	ADRF5	SACS3	SACS2	SACS1	SACS0
R/W	R/W	R	R/W	R/W	R/W	R/W	R/W	R/W
POR	0	0	0	0	0	0	0	0

- Bit 7 **START**: Start the A/D conversion
0→1→0: Start
This bit is used to initiate an A/D conversion process. The bit is normally low but if set high and then cleared low again, the A/D Converter will initiate a conversion process.
- Bit 6 **ADBZ**: A/D Converter busy flag
0: No A/D conversion is in progress
1: A/D conversion is in progress
This read only flag is used to indicate whether the A/D conversion is in progress or not. When the START bit is set from low to high and then to low again, the ADBZ flag will be set to 1 to indicate that the A/D conversion is initiated. The ADBZ flag will be cleared to 0 after the A/D conversion is complete.
- Bit 5 **ADCEN**: A/D Converter function enable control
0: Disable
1: Enable
This bit controls the A/D internal function. This bit should be set to one to enable the A/D Converter. If the bit is set low, then the A/D Converter will be switched off reducing the device power consumption. When the A/D Converter function is disabled, the contents of the A/D data register pair known as SADOH and SADOL will be unchanged.
- Bit 4 **ADRF5**: A/D Converter data format select
0: A/D Converter data format → SADOH=D[11:4]; SADOL=D[3:0]
1: A/D Converter data format → SADOH=D[11:8]; SADOL=D[7:0]
This bit controls the format of the 12-bit converted A/D value in the two A/D data registers. Details are provided in the A/D data register section.
- Bit 3~0 **SACS3~SACS0**: A/D Converter external analog channel input select
0000: Non-existed channel, the input will be floating if selected
0001: AN1
0010: AN2
0011: AN3
0100: AN4
0101: AN5
0110: AN6
0111: AN7
1000~1111: Non-existed channel, the input will be floating if selected

• **SADC1 Register**

Bit	7	6	5	4	3	2	1	0
Name	SAINS2	SAINS1	SAINS0	SAVRS1	SAVRS0	SACKS2	SACKS1	SACKS0
R/W	R/W	R/W	R/W	R/W	R/W	R/W	R/W	R/W
POR	0	0	0	0	0	0	0	0

- Bit 7~5 **SAINS2~SAINS0**: A/D Converter input signal select
000: External signal – External analog channel input
010: Reserved, forbidden to be used
001/011/100: Reserved, connected to ground
101/110: External signal – External analog channel input
111: Forbidden to be used

Care must be taken if the SAINS2~SAINS0 bits are set from “001~010” to select the internal analog signal to be converted. When the internal analog signal is selected to be converted, the external input pin must never be selected as the A/D input signal by properly setting the SACS3~SACS0 bits with a value from 1000 to 1111. Otherwise, the external channel input will be connected together with the internal analog signal. This will result in unpredictable situations such as an irreversible damage.

- Bit 4~3 **SAVRS1~SAVRS0**: A/D Converter reference voltage select
- 00: VREF pin
 - 01: Internal A/D Converter power, AV_{DD}
 - 10: Reserved, forbidden to be used
 - 11: Internal A/D Converter power, AV_{DD}

These bits are used to select the A/D Converter reference voltage. Care must be taken if the SAVRS1~SAVRS0 bits are set to any other values except “00” to select the internal reference voltage source. When the internal A/D Converter power is selected as the reference voltage, the VREF pin cannot be configured as the reference voltage input by properly configuring the corresponding pin-shared function control bits. Otherwise, the A/D Converter internal reference voltage source will be connected together with the external reference voltage input on the VREF pin. This will result in unpredictable situations.

- Bit 2~0 **SACKS2~SACKS0**: A/D conversion clock source select
- 000: f_{sys}
 - 001: f_{sys}/2
 - 010: f_{sys}/4
 - 011: f_{sys}/8
 - 100: f_{sys}/16
 - 101: f_{sys}/32
 - 110: f_{sys}/64
 - 111: f_{sys}/128

These three bits are used to select the clock source for the A/D Converter.

• **SADC2 Register**

Bit	7	6	5	4	3	2	1	0
Name	VBGREN	—	—	—	—	—	—	—
R/W	R/W	—	—	—	—	—	—	—
POR	0	—	—	—	—	—	—	—

- Bit 7 **VBGREN**: Independent reference bandgap enable control
- 0: Disable
 - 1: Enable

When the VBGREN bit is cleared to zero, the VBG is in a pull low state.

- Bit 6~2 Unimplemented, read as “0”
- Bit 1 Unimplemented, read as “1”
- Bit 0 Reserved, this bit clear to “0”

A/D Converter Operation

The START bit in the SADC0 register is used to start the A/D conversion. When the microcontroller sets this bit from low to high and then low again, an analog to digital conversion cycle will be initiated.

The ADBZ bit in the SADC0 register is used to indicate whether the analog to digital conversion process is in progress or not. This bit will be automatically set to 1 by the microcontroller after an A/D conversion is successfully initiated. When the A/D conversion is complete, the ADBZ will be cleared to 0. In addition, the corresponding A/D interrupt request flag will be set in the interrupt control register, and if the interrupts are enabled, an appropriate internal interrupt signal will be generated. This A/D internal interrupt signal will direct the program flow to the associated A/D internal interrupt address for processing. If the A/D internal interrupt is disabled, the microcontroller can poll the ADBZ bit in the SADC0 register to check whether it has been cleared as an alternative method of detecting the end of an A/D conversion cycle.

The clock source for the A/D Converter, which originates from the system clock f_{SYS} , can be chosen to be either f_{SYS} or a subdivided version of f_{SYS} . The division ratio value is determined by the SACKS2~SACKS0 bits in the SADC1 register. Although the A/D clock source is determined by the system clock f_{SYS} and by bits SACKS2~SACKS0, there are some limitations on the maximum A/D clock source speed that can be selected. As the recommended range of permissible A/D clock period, t_{ADCK} , is from 0.5 μ s to 10 μ s, care must be taken for system clock frequencies. For example, as the system clock operates at a frequency of 8MHz, the SACKS2~SACKS0 bits should not be set to 000, 001 or 111. Doing so will give A/D clock periods that are less than the minimum or larger than the maximum A/D clock period which may result in inaccurate A/D conversion values. Refer to the following table for examples, where values marked with an asterisk * show where, depending upon the device, special care must be taken, as the values may be exceeding than the specified minimum A/D Clock Period.

However, the recommended A/D clock period is from 1 μ s to 2 μ s if the input signal to be converted is the temperature sensor output voltage, care must be taken for system clock frequencies. For examples, the system clock operates at a frequency of 12MHz, the SACKS2~SACKS0 bits should be set to 100, where values marked with an asterisk # in the A/D Clock Period Examples table.

f_{SYS}	A/D Clock Period (t_{ADCK})							
	SACKS[2:0] =000 (f_{SYS})	SACKS[2:0] =001 ($f_{SYS}/2$)	SACKS[2:0] =010 ($f_{SYS}/4$)	SACKS[2:0] =011 ($f_{SYS}/8$)	SACKS[2:0] =100 ($f_{SYS}/16$)	SACKS[2:0] =101 ($f_{SYS}/32$)	SACKS[2:0] =110 ($f_{SYS}/64$)	SACKS[2:0] =111 ($f_{SYS}/128$)
1MHz	1 μ s	2 μ s	4 μ s	8 μ s	16 μ s *	32 μ s *	64 μ s *	128 μ s *
2MHz	500ns	1 μ s	2 μ s	4 μ s	8 μ s	16 μ s *	32 μ s *	64 μ s *
4MHz	250ns *	500ns	1 μ s	2 μ s	4 μ s	8 μ s	16 μ s *	32 μ s *
8MHz	125ns *	250ns *	500ns	1 μ s	2 μ s	4 μ s	8 μ s	16 μ s *
12MHz	83ns*	167ns*	333ns*	667ns	1.33 μ s#	2.67 μ s	5.33 μ s	10.67 μ s*

A/D Clock Period Examples

Controlling the power on/off function of the A/D Converter circuitry is implemented using the ADCEN bit in the SADC0 register. This bit must be set high to power on the A/D Converter. When the ADCEN bit is set high to power on the A/D Converter internal circuitry a certain delay, as indicated in the timing diagram, must be allowed before an A/D conversion is initiated. Even if no pins are selected for use as A/D inputs, if the ADCEN bit is high, then some power will still be consumed. In power conscious applications it is therefore recommended that the ADCEN is set low to reduce power consumption when the A/D Converter function is not being used.

A/D Converter Reference Voltage

The reference voltage supply to the A/D Converter can be supplied from the positive power supply pin, AVDD, or from an external reference source supplied on pin VREF determined by the SAVRS1~SAVRS0 bits in the SADC1 register. As the VREF pin is pin-shared with other functions, when the VREF pin is selected as the reference voltage supply pin, the VREF pin corresponding pin-shared function control bit should first be properly configured to enable the VREF pin function then the other pin functions will be disabled automatically. However, if the AV_{DD} is selected as the reference voltage, the VREF pin must not be configured as the reference voltage input function to avoid that the internal reference voltage source is connected to the external VREF voltage. The analog input values must not be allowed to exceed the value of the selected A/D reference voltage.

A/D Converter Input Signals

All the external A/D analog channel input pins are pin-shared with the I/O pins as well as other functions. The corresponding control bits for each A/D external input pin in the PxS0 and PxS1 register determine whether the input pins are setup as A/D Converter analog inputs or whether they have other functions. If the pin is setup to be as an A/D analog channel input, the original pin functions will be disabled. In this way, pins can be changed under program control to change their function between A/D inputs and other functions. All pull high resistors, which are setup through register programming, will be automatically disconnected if the pins are setup as A/D inputs. Note that it is not necessary to first setup the A/D pin as an input in the port control register to enable the A/D input as when the pin-shared function control bits enable an A/D input, the status of the port control register will be overridden.

If the external channel input is selected to be converted, the SAINS2~SAINS0 bits should be set to “000” and the SACS3~SACS0 bits can determine which external channel is selected. If the internal analog signal is selected to be converted, the SACS3~SACS0 bits must be configured with a value from 1000 to 1111 to switch off the external analog channel input. Otherwise, the internal analog signal will be connected together with the external channel input. This will result in unpredictable situations.

SAINS[2:0]	SACS[3:0]	Input Signals	Description
000, 101, 110	0001~0111	AN1~AN7	External pin analog input
	0000, 1000~1111	—	Non-existed channel, input is floating
010	0000, 1000~1111	—	Reserved, forbidden to be used
001, 011, 100	0000, 1000~1111	—	Reserved, connected to ground

A/D Converter Input Signal Selection

Conversion Rate and Timing Diagram

A complete A/D conversion contains two parts, data sampling and data conversion. The data sampling which is defined as t_{ADS} takes 4 A/D clock cycles and the data conversion takes 12 A/D clock cycles. Therefore a total of 16 A/D clock cycles for an external input A/D conversion which is defined as t_{ADC} are necessary.

Maximum single A/D conversion rate = A/D clock period / 16 (External channel input signal)

The accompanying diagram shows graphically the various stages involved in an analog to digital conversion process and its associated timing. After an A/D conversion process has been initiated by the application program, the microcontroller internal hardware will begin to carry out the conversion, during which time the program can continue with other functions. The time taken for the A/D conversion is 16 t_{ADCK} clock cycles where t_{ADCK} is equal to the A/D clock period.

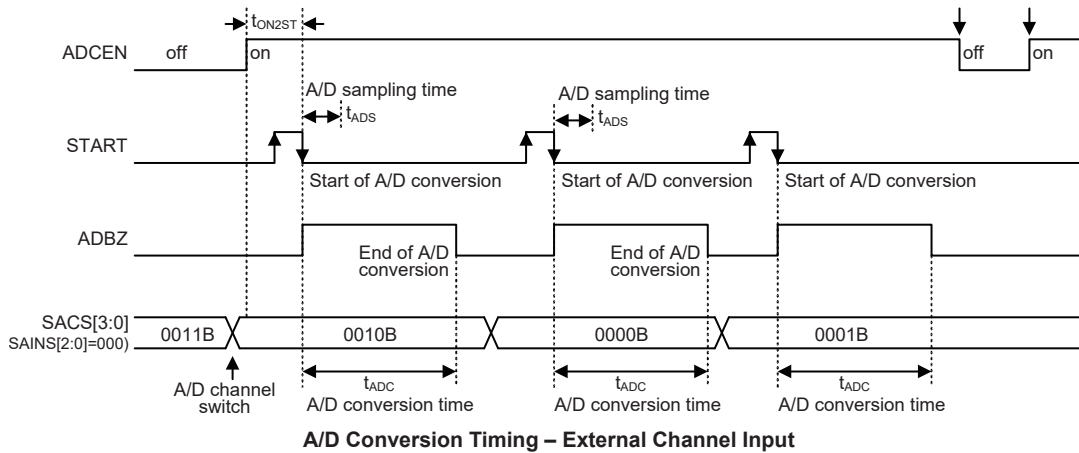

Summary of A/D Conversion Steps

The following summarises the individual steps that should be executed in order to implement an A/D conversion process.

- Step 1
Select the required A/D conversion clock by correctly programming bits SACKS2~SACKS0 in the SADC1 register.
- Step 2
Enable the A/D by setting the ADCEN bit in the SADC0 register to one.
- Step 3
Select which signal is to be connected to the internal A/D Converter by correctly configuring the SAINS2~SAINS0 bits
Select the external channel input to be converted, go to Step 4.
Select the internal analog signal to be converted, go to Step 5.
- Step 4
If the A/D input signal comes from the external channel input selecting by configuring the SAINS bit field, the corresponding pins should be configured as A/D input function by configuring the relevant pin-shared function control bits. The desired analog channel then should be selected by configuring the SACS bit field. After this step, go to Step 6.
- Step 5
Before the A/D input signal is selected to come from the internal analog signal by configuring the SAINS bit field, the corresponding external input pin must be switched to a non-existent channel input by setting the SACS3~SACS0 bits with a value from 0000, 1000 to 1111. The desired internal analog signal then can be selected by configuring the SAINS bit field. After this step, go to Step 6.
- Step 6
Select the reference voltage source by configuring the SAVRS1~SAVRS0 bits in the SADC1 register.
- Step 7
Select A/D Converter output data format by setting the ADRFS bit in the SADC0 register.
- Step 8
If A/D conversion interrupt is used, the interrupt control registers must be correctly configured to ensure the A/D interrupt function is active. The master interrupt control bit, EMI, and the A/D conversion interrupt control bit, ADE, must both be set high in advance.

- Step 9
 The A/D conversion procedure can now be initialized by setting the START bit from low to high and then low again.
- Step 10
 If A/D conversion is in progress, the ADBZ flag will be set high. After the A/D conversion process is complete, the ADBZ flag will go low and then the output data can be read from SADOH and SADOL registers.

Note: When checking for the end of the conversion process, if the method of polling the ADBZ bit in the SADC0 register is used, the interrupt enable step above can be omitted.

Programming Considerations

During microcontroller operations where the A/D Converter is not being used, the A/D internal circuitry can be switched off to reduce power consumption, by clearing bit ADCEN to 0 in the SADC0 register. When this happens, the internal A/D Converter circuits will not consume power irrespective of what analog voltage is applied to their input lines. If the A/D Converter input lines are used as normal I/Os, then care must be taken as if the input voltage is not at a valid logic level, then this may lead to some increase in power consumption.

A/D Conversion Function

As these devices contain a 12-bit A/D Converter, its full-scale converted digitised value is equal to FFFH. Since the full-scale analog input value is equal to the actual A/D Converter reference voltage, V_{REF} , this gives a single bit analog input value of V_{REF} divided by 4096.

$$1 \text{ LSB} = V_{REF} \div 4096$$

The A/D Converter input voltage value can be calculated using the following equation:

$$\text{A/D input voltage} = \text{A/D output digital value} \times (V_{REF} \div 4096)$$

The diagram shows the ideal transfer function between the analog input value and the digitised output value for the A/D Converter. Except for the digitised zero value, the subsequent digitised values will change at a point 0.5 LSB below where they would change without the offset, and the last full scale digitised value will change at a point 1.5 LSB below the V_{REF} level. Note that here the V_{REF} voltage is the actual A/D Converter reference voltage determined by the SAVRS field.

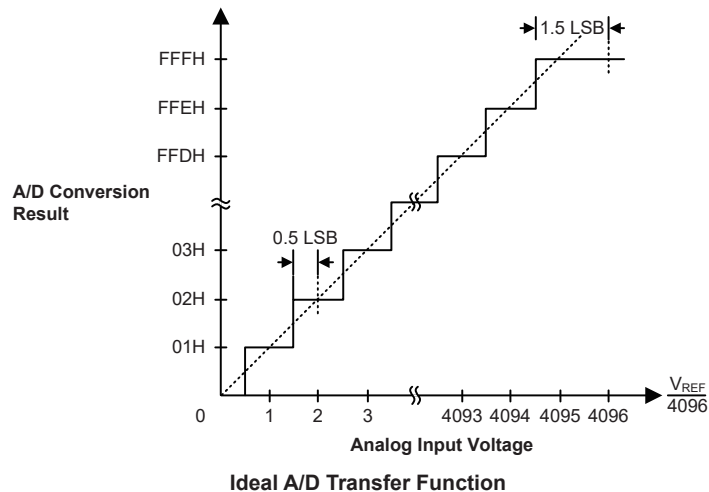

A/D Conversion Programming Examples

The following two programming examples illustrate how to setup and implement an A/D conversion. In the first example, the method of polling the ADBZ bit in the SADC0 register is used to detect when the conversion cycle is complete, whereas in the second example, the A/D interrupt is used to determine when the conversion is complete.

Example: using an ADBZ polling method to detect the end of conversion

```

clr ADE          ; disable ADC interrupt
mov a,03H
mov SADC1,a      ; select fsys/8 as A/D clock
set ADCEN
mov a,0Ch        ; setup PBS0 to configure pin AN1
mov PBS0,a
mov a,21h
mov SADC0,a      ; enable and connect AN1 channel to A/D Converter
:
start_conversion:
clr START        ; high pulse on start bit to initiate conversion
set START        ; reset A/D
clr START        ; start A/D
polling_EOC:
sz ADBZ          ; poll the SADC0 register ADBZ bit to detect end of A/D conversion
jmp polling_EOC ; continue polling
mov a,SADOL      ; read low byte conversion result value
mov SADOL_buffer,a ; save result to user defined register
mov a,SADOH      ; read high byte conversion result value
mov SADOH_buffer,a ; save result to user defined register
:
:
jmp start_conversion ; start next A/D conversion

```

Example: using the interrupt method to detect the end of conversion

```

clr ADE          ; disable ADC interrupt
mov a,03H
mov SADC1,a      ; select fsys/8 as A/D clock
set ADCEN
mov a,0Ch        ; setup PBS0 to configure pin AN1
mov PBS0,a
mov a,21h
mov SADC0,a      ; enable and connect AN1 channel to A/D Converter
Start_conversion:
clr START        ; high pulse on START bit to initiate conversion
set START        ; reset A/D
clr START        ; start A/D
clr ADF          ; clear ADC interrupt request flag
set ADE          ; enable ADC interrupt
set EMI          ; enable global interrupt
:
:
; ADC interrupt service routine
ADC_ISR:
mov acc_stack,a  ; save ACC to user defined memory
mov a,STATUS
mov status_stack,a ; save STATUS to user defined memory
:
:

```

```

mov a,SADOL          ; read low byte conversion result value
mov SADOL_buffer,a  ; save result to user defined register
mov a,SADOH          ; read high byte conversion result value
mov SADOH_buffer,a  ; save result to user defined register
:
:
EXIT_INT_ISR:
mov a,status_stack
mov STATUS,a        ; restore STATUS from user defined memory
mov a,acc_stack     ; restore ACC from user defined memory
reti
    
```

Electronic Paper Display – EPD

This device contains an electronic paper display (EPD) driver function, which has the advantage of good readability. With its high black and white colour contrast and reusable features, it is suitable for use in applications such as electronic shelf labels, smart cards and consumer electronics. The EPD driver consists of 64 Segments and 2 Background/Common selectable outputs.

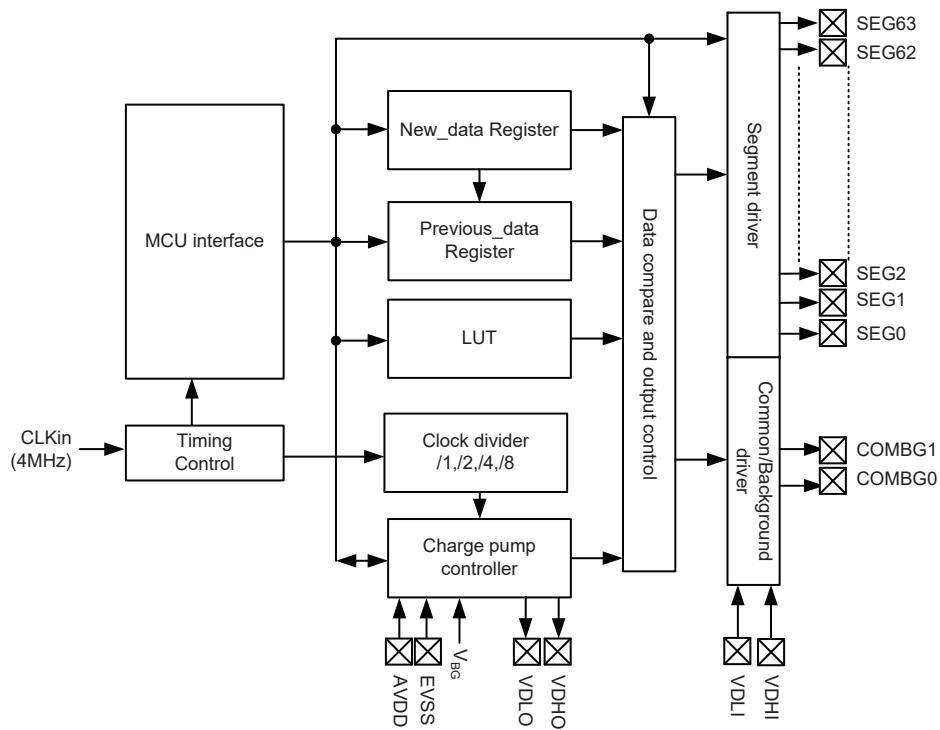

Note: The EPD driver clock source is provided by the internal clock, CLKIn, which is supplied by the HIRC oscillator with the output frequency of 4MHz.

EPD Block Diagram

EPD Driver Voltage

The EPD driver has a three level driving voltage to match the EPD characteristic. The driving voltage is generated by charge pump circuit. Note that it is necessary to first setup the VBGREN bit in the SADC2 register to enable the independent reference bandgap when the EPD Charge pump is enabled, the reference voltage, V_{BG} , will be provided to charge pump. The charge pump switching frequency is from HIRC of 4MHz, the rising time is about 40ms at $V_{DD}=3V$ for charge pump to start-up.

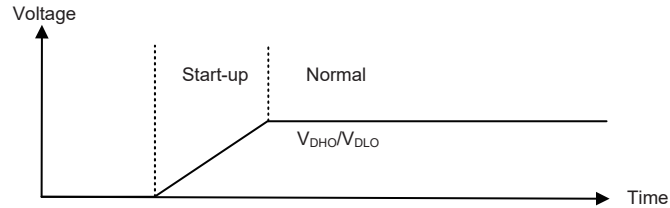

The V_{DHO}/V_{DLO} Charge Stage Definition

EPD Driver Power Supply Sequence

If the V_{DH} and V_{DL} power is supplied from external power, it is strongly recommended to follow the Holtek power supply sequence requirement. If the power supply sequence requirement is not followed, it may result in malfunction.

Holtek Power Supply Sequence Requirement:

1. Power-on sequence:

Turn on the power of V_{DD} and AV_{DD} first and then turn on the power of V_{DH} and V_{DL} .

2. Power-off sequence:

Turn off the power of V_{DH} and V_{DL} first and then turn off the power of V_{DD} and AV_{DD} .

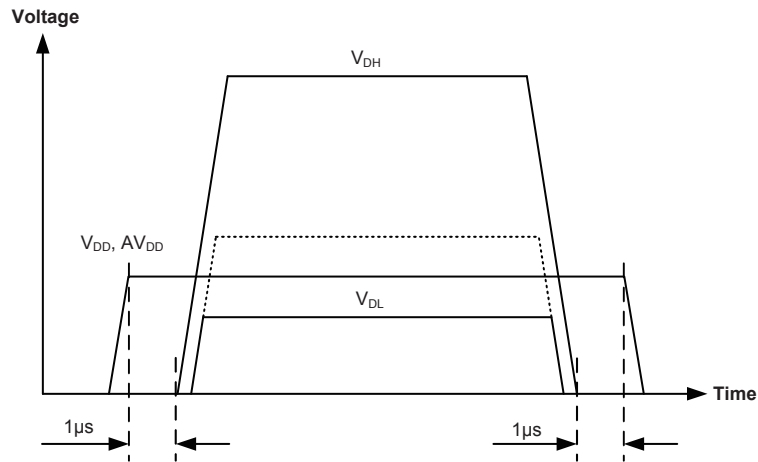

EPD Power Supply Sequence

EPD Driver Data Display

The device provides an area of embedded data for the EPD display. These data registers are located from 00H to 11H in Sector 3.

The EPD display data contains two area to store new_data and previous_data. User can used EEPROM to backup previous_data display data. The PEPD0~PEPD7 and PEPDBG registers are used to store previous display data, while the NEPD0~NEPD7 and NEPDBG registers are used to store new display data.

After display refresh, user can set NMP bit="1", move new_data to previous data registers from NEPD0~NEPD7 and NEPDBG data registers for next display refresh.

Note that user must write the full data to registers at once, if write less the register bytes, the contents of the previous_data register will be incorrect. In this case, the outcome will be that the result of the data comparison between the new_data register and the previous_data register will be incorrect.

EPD Driver Registers

The overall EPD driver function is controlled using a series of registers. Three control registers exist to setup the operating and control function of the EPD Driver. A VDH_LV register exists to select the V_{DH} level voltage, while VDL_LV register exists to select the V_{DL} level voltage. The PEPD0~PEPD7 and PEPDBG registers are used to store previous display data, while the NEPD0~NEPD7 and NEPDBG registers are used to store new display data. In addition, LUT Registers are control the EPD output waveform.

Register Name	Bit							
	7	6	5	4	3	2	1	0
EPDC0	EPDEN	—	—	—	—	EPDBUSY	DRF	NMP
EPDC1	—	CPEN	VDLH_EN	DDX	CPC1	CPC0	SGM_FL	VCOM_FL
EPDC2	CBS3	CBS2	CBS1	CBS0	—	P2	P1	P0
VDH_LV	—	VDH_LV6	VDH_LV5	VDH_LV4	VDH_LV3	VDH_LV2	VDH_LV1	VDH_LV0
VDL_LV	—	VDL_LV6	VDL_LV5	VDL_LV4	VDL_LV3	VDL_LV2	VDL_LV1	VDL_LV0
PEPD0	PS0	PS1	PS2	PS3	PS4	PS5	PS6	PS7
PEPD1	PS8	PS9	PS10	PS11	PS12	PS13	PS14	PS15
⋮	⋮	⋮	⋮	⋮	⋮	⋮	⋮	⋮
PEPD7	PS56	PS57	PS58	PS59	PS60	PS61	PS62	PS63
PEPDBG	PBG	—	—	—	—	—	—	—
NEPD0	NS0	NS1	NS2	NS3	NS4	NS5	NS6	NS7
NEPD1	NS8	NS9	NS10	NS11	NS12	NS13	NS14	NS15
⋮	⋮	⋮	⋮	⋮	⋮	⋮	⋮	⋮
NEPD7	NS56	NS57	NS58	NS59	NS60	NS61	NS62	NS63
NEPDBG	NBG	—	—	—	—	—	—	—

EPD Function Register List

• **EPDC0 Register**

Bit	7	6	5	4	3	2	1	0
Name	EPDEN	—	—	—	—	EPDBUSY	DRF	NMP
R/W	R/W	—	—	—	—	R	R/W	R/W
POR	0	—	—	—	—	0	0	0

Bit 7 **EPDEN**: EPD driver enable control
 0: Disable
 1: Enable
 Before set the EPDEN bit to high, the program must be set the VBGREN bit first and waiting for V_{BG} output voltage stability.

Bit 6~3 Unimplemented, read as “0”

Bit 2 **EPDBUSY**: EPD busy flag
 0: EPD idle
 1: EPD busy
 This read only flag is used to indicate whether the EPD is busy or not. When the EPDEN bit is set high and the charge pump circuit is enabled, the EPDBUSY flag will be set high from low to indicate that the EPD is busy.
 The EPD can be refreshed data by setting the DRF bit to high, the EPDBUSY flag will be cleared to zero. The EPDBUSY flag will be set high again after the EPD data refresh complete.

Bit 1 **DRF**: Display refresh control
 0: Disable or refresh finished
 1: Enable refresh and in progress
 If DRF bit is set high, EPD driver will refresh display according to the new_data registers, previous_data registers and LUT registers. After completing display fresh , the DRF bit will be cleared to zero automatically. Detecting when the display refresh has finished can be implemented by polling the DRF=0. The display refresh take hundreds ms to a few seconds time interval, the data registers cannot be charged when display refreshing to avoid display abnormal. Note that this bit cannot be cleared to zero by application programs.

Bit 0 **NMP**: Move the new_data from new_data registers to previous_data registers
 0: Disable or move finished
 1: Enable move function and in progress
 The EPD driver supports data comparison, the EPD driving output waveform is generated by the corresponding LUT based on the DDX bit setting and the result of the new_data registers and the previous_data registers comparison.
 If NMP is set high, EPD driver will move new_data from new_data register to previous_data registers automatically for data comparison function. After finishing moving, NMP will be cleared to zero automatically. Note that this bit cannot be cleared to zero by application programs.
 The data moving must exist a delay time, detecting whether the data moving has finished can be implemented by polling the NMP=0.

• **EPDC1 register**

Bit	7	6	5	4	3	2	1	0
Name	—	CPEN	VDLH_EN	DDX	CPC1	CPC0	SGM_FL	VCOM_FL
R/W	—	R/W	R/W	R/W	R/W	R/W	R/W	R/W
POR	—	1	1	1	0	0	1	1

Bit 7 Unimplemented, read as “0”

Bit 6 **CPEN**: Charge Pump enable control
 0: Disable
 1: Enable (default)

- Bit 5 **VDLH_EN**: V_{DLI}/V_{DHI} source select
 0: From VDLI/VDHI pin (VDLO/VDHO is in a floating state, external power supply)
 1: Internal charge pump output VDLO/VDHO (default)
 Note: If EPD power source selected from internal charge pump output, the VDLI/VDHI pins must connect to VDLO/VDHO pins.
- Bit 4 **DDX**: Data index control
 0: “0: white, 1: black/red”
 1: “0: black/red, 1: white” (default)
 The white and black/red mean that the electronic paper color is white, black or red. The paper color selection depends on the setting of DDX bit. In addition, the black/red paper color which is select to display depends upon the condition of the V_{DH} and V_{DL} voltages.
- Bit 3~2 **CPC1~CPC0**: Charge pump clock source select
 00: 4MHz (default)
 01: 4MHz/2
 10: 4MHz/4
 11: 4MHz/8
 The Charge pump clock source is supplied by the HIRC oscillator with the output frequency of 4MHz and then passes through a divider, the division ratio of which is selected by programming the CPC1~CPC0 bits. Before setting the EPDEN bit high, the program must be set the CPC1~CPC0 bits first.
- Bit 1 **SGM_FL**: Segment and BG level selection when EPD driver is enabled
 0: Floating
 1: Ground (default)
 Note: When EPD driver is disabled, the Segment and BG pins level is ground.
- Bit 0 **VCOM_FL**: COM level selection when EPD driver is enabled
 0: Floating
 1: Ground (default)
 Note: When EPD driver is disabled, the COM pin level is ground.

• **EPDC2 register**

Bit	7	6	5	4	3	2	1	0
Name	—	—	CBS1	CBS0	—	P2	P1	P0
R/W	—	—	R/W	R/W	—	R/W	R/W	R/W
POR	—	—	1	0	—	0	1	1

- Bit 7~6 Unimplemented, read as “0”
- Bit 5 **CBS1**: COMBG1 pin output selection
 0: COMBG1 pin is set as COM pin
 1: COMBG1 pin is set as BG pin
- Bit 4 **CBS0**: COMBG0 pin output selection
 0: COMBG0 pin is set as COM pin
 1: COMBG0 pin is set as BG pin
- Bit 3 Unimplemented, read as “0”
- Bit 2~0 **P2~P0**: The frame rate control
 000: 10Hz
 001: 20Hz
 010: 40Hz
 011: 50Hz (default)
 100: 57Hz
 101: 67Hz
 110: 80Hz
 111: 100Hz

• **VDH_LV register**

Bit	7	6	5	4	3	2	1	0
Name	—	VDH_LV6	VDH_LV5	VDH_LV4	VDH_LV3	VDH_LV2	VDH_LV1	VDH_LV0
R/W	—	R/W	R/W	R/W	R/W	R/W	R/W	R/W
POR	—	1	1	1	1	1	1	1

Bit 7 Unimplemented, read as “0”

Bit 6~0 **VDH_LV6~VDH_LV0**: V_{DH} level voltage selection

VDH_LV[6:0]	V _{DH}	VDH_LV[6:0]	V _{DH}	VDH_LV[6:0]	V _{DH}
0000000	5.00	0011000	7.40	0110000	9.80
0000001	5.10	0011001	7.50	0110001	9.90
0000010	5.20	0011010	7.60	0110010	10.00
0000011	5.30	0011011	7.70	0110011	10.10
0000100	5.40	0011100	7.80	0110100	10.20
0000101	5.50	0011101	7.90	0110101	10.30
0000110	5.60	0011110	8.00	0110110	10.40
0000111	5.70	0011111	8.10	0110111	10.50
0001000	5.80	0100000	8.20	0111000	10.60
0001001	5.90	0100001	8.30	0111001	10.70
0001010	6.00	0100010	8.40	0111010	10.80
0001011	6.10	0100011	8.50	0111011	10.90
0001100	6.20	0100100	8.60	0111100	11.00
0001101	6.30	0100101	8.70	0111101	11.10
0001110	6.40	0100110	8.80	0111110	11.20
0001111	6.50	0100111	8.90	0111111	11.30
0010000	6.60	0101000	9.00	1000000	11.40
0010001	6.70	0101001	9.10	1000001	11.50
0010010	6.80	0101010	9.20	1000010	11.60
0010011	6.90	0101011	9.30	1000011	11.70
0010100	7.00	0101100	9.40	1000100	11.80
0010101	7.10	0101101	9.50	1000101	11.90
0010110	7.20	0101110	9.60	1000110	12.00
0010111	7.30	0101111	9.70	others	12.00

These bits default value is 1111111B, the V_{DH0} output voltage is equal to 12V.

• **VDL_LV register**

Bit	7	6	5	4	3	2	1	0
Name	—	VDL_LV6	VDL_LV5	VDL_LV4	VDL_LV3	VDL_LV2	VDL_LV1	VDL_LV0
R/W	—	R/W	R/W	R/W	R/W	R/W	R/W	R/W
POR	—	1	1	1	1	1	1	1

Bit 7 Unimplemented, read as “0”

Bit 6~0 **VDL_LV6~VDL_LV0**: V_{DH} level voltage selection

VDL_LV[6:0]	V_{DL}	VDL_LV[6:0]	V_{DL}	VDL_LV[6:0]	V_{DL}
0000000	2.50	0011000	3.70	0110000	4.90
0000001	2.55	0011001	3.75	0110001	4.95
0000010	2.60	0011010	3.80	0110010	5.00
0000011	2.65	0011011	3.85	0110011	5.05
0000100	2.70	0011100	3.90	0110100	5.10
0000101	2.75	0011101	3.95	0110101	5.15
0000110	2.80	0011110	4.00	0110110	5.20
0000111	2.85	0011111	4.05	0110111	5.25
0001000	2.90	0100000	4.10	0111000	5.30
0001001	2.95	0100001	4.15	0111001	5.35
0001010	3.00	0100010	4.20	0111010	5.40
0001011	3.05	0100011	4.25	0111011	5.45
0001100	3.10	0100100	4.30	0111100	5.50
0001101	3.15	0100101	4.35	0111101	5.55
0001110	3.20	0100110	4.40	0111110	5.60
0001111	3.25	0100111	4.45	0111111	5.65
0010000	3.30	0101000	4.50	1000000	5.70
0010001	3.35	0101001	4.55	1000001	5.75
0010010	3.40	0101010	4.60	1000010	5.80
0010011	3.45	0101011	4.65	1000011	5.85
0010100	3.50	0101100	4.70	1000100	5.90
0010101	3.55	0101101	4.75	1000101	5.95
0010110	3.60	0101110	4.80	1000110	6.00
0010111	3.65	0101111	4.85	others	6.00

These bits default value is 1111111B, the V_{DLO} output voltage is equal to 6V.

LUT Registers

The LUT registers include V_{COM} LUT (LUTV) registers, BlackBlack LUT (LUT_KK) registers, BlackWhite LUT (LUT_KW) registers, WhiteBlack LUT (LUT_WK) registers and WhiteWhite LUT (LUT_WW) registers.

They are used to generate EPD output waveform according to the results of data comparison and EPD characteristics.

The relationships among DDX bit, display data and the corresponding LUT are shown as the table.

DDX=1	
Previous_data → New_data	The corresponding LUT
0 → 0	LUT_KK
0 → 1	LUT_KW
1 → 0	LUT_WK
1 → 1	LUT_WW

DDX=0	
Previous_data → New_data	The corresponding LUT
0 → 0	LUT_WW
0 → 1	LUT_WK
1 → 0	LUT_KW
1 → 1	LUT_KK

These registers only be written in when the EPD is busy. These registers cannot be charged when display refreshing to avoid display abnormal. Each type LUT registers can store 5 groups of data, they are used to set the EPD driving voltage, frames number and repeat number for each group.

LUT	Register Name	Bit							
V _{COM}	LVLn_V1	LVLn_V11	LVLn_V10	FRMn_V15	FRMn_V14	FRMn_V13	FRMn_V12	FRMn_V11	FRMn_V10
	LVLn_V2	LVLn_V21	LVLn_V20	FRMn_V25	FRMn_V24	FRMn_V23	FRMn_V22	FRMn_V21	FRMn_V20
	PHSn_V	PHSn_V7	PHSn_V6	PHSn_V5	PHSn_V4	PHSn_V3	PHSn_V2	PHSn_V1	PHSn_V0
BlackBlack	LVLn_KK1	LVLn_KK11	LVLn_KK10	FRMn_KK15	FRMn_KK14	FRMn_KK13	FRMn_KK12	FRMn_KK11	FRMn_KK10
	LVLn_KK2	LVLn_KK21	LVLn_KK20	FRMn_KK25	FRMn_KK24	FRMn_KK23	FRMn_KK22	FRMn_KK21	FRMn_KK20
	PHSn_KK	PHSn_KK7	PHSn_KK6	PHSn_KK5	PHSn_KK4	PHSn_KK3	PHSn_KK2	PHSn_KK1	PHSn_KK0
BlackWhite	LVLn_KW1	LVLn_KW11	LVLn_KW10	FRMn_KW15	FRMn_KW14	FRMn_KW13	FRMn_KW12	FRMn_KW11	FRMn_KW10
	LVLn_KW2	LVLn_KW21	LVLn_KW20	FRMn_KW25	FRMn_KW24	FRMn_KW23	FRMn_KW22	FRMn_KW21	FRMn_KW20
	PHSn_KW	PHSn_KW7	PHSn_KW6	PHSn_KW5	PHSn_KW4	PHSn_KW3	PHSn_KW2	PHSn_KW1	PHSn_KW0
WhiteBlack	LVLn_WK1	LVLn_WK11	LVLn_WK10	FRMn_WK15	FRMn_WK14	FRMn_WK13	FRMn_WK12	FRMn_WK11	FRMn_WK10
	LVLn_WK2	LVLn_WK21	LVLn_WK20	FRMn_WK25	FRMn_WK24	FRMn_WK23	FRMn_WK22	FRMn_WK21	FRMn_WK20
	PHSn_WK	PHSn_WK7	PHSn_WK6	PHSn_WK5	PHSn_WK4	PHSn_WK3	PHSn_WK2	PHSn_WK1	PHSn_WK0
WhiteWhite	LVLn_WW1	LVLn_WW11	LVLn_WW10	FRMn_WW15	FRMn_WW14	FRMn_WW13	FRMn_WW12	FRMn_WW11	FRMn_WW10
	LVLn_WW2	LVLn_WW21	LVLn_WW20	FRMn_WW25	FRMn_WW24	FRMn_WW23	FRMn_WW22	FRMn_WW21	FRMn_WW20
	PHSn_WW	PHSn_WW7	PHSn_WW6	PHSn_WW5	PHSn_WW4	PHSn_WW3	PHSn_WW2	PHSn_WW1	PHSn_WW0

EPD LUT Register List (n=0~4)

• **LVLn_V1 Register (n=0~4)**

Bit	7	6	5	4	3	2	1	0
Name	LVLn_V11	LVLn_V10	FRMn_V15	FRMn_V14	FRMn_V13	FRMn_V12	FRMn_V11	FRMn_V10
R/W	R/W	R/W	R/W	R/W	R/W	R/W	R/W	R/W
POR	0	0	0	0	0	0	0	0

Bit 7~6 **LVLn_V11~LVLn_V10:** V_{COM} LUT Phase n voltage Level 1 selection

- 00: V_{DL}
- 01: V_{DH}
- 10: 0V
- 11: Floating

Bit 5~0 **FRMn_V15~FRMn_V10:** V_{COM} LUT Phase n frame 1 number selection

- 000000: 0
- 000001: 1
- ⋮
- 111111: 63

If FRMn_V1[5:0] and FRMn_V2[5:0] bits are both set to “000000”, the Phase n and later phases will have no waveform output, These phases output are all V_{SS} level even if those groups have setting values.

For example, when FRM2_V1[5:0] and FRM2_V2[5:0] bits are both set to “000000”, the Phase 2 frame number is 0. The Phase 2~4 have no waveform output, these phases output are all V_{SS} level.

• **LVLn_V2 Register (n=0~4)**

Bit	7	6	5	4	3	2	1	0
Name	LVLn_V21	LVLn_V20	FRMn_V25	FRMn_V24	FRMn_V23	FRMn_V22	FRMn_V21	FRMn_V20
R/W	R/W	R/W	R/W	R/W	R/W	R/W	R/W	R/W
POR	0	0	0	0	0	0	0	0

Bit 7~6 **LVLn_V21~LVLn_V20**: V_{COM} LUT Phase n voltage Level 2 selection

- 00: V_{DL}
- 01: V_{DH}
- 10: 0V
- 11: Floating

Bit 5~0 **FRMn_V25~FRMn_V20**: V_{COM} LUT Phase n frame 2 number selection

- 000000: 0
- 000001: 1
- :
- 111111: 63

If FRMn_V1[5:0] and FRMn_V2[5:0] bits are both set to “000000”, the Phase n and later phases will have no waveform output, These phases output are all V_{SS} level even if those groups have setting values.

For example, when FRM2_V1[5:0] and FRM2_V2[5:0] bits are both set to “000000”, the Phase 2 frame number is 0. The Phase 2~4 have no waveform output, these phases output are all V_{SS} level.

• **PHSn_V Register (n=0~4)**

Bit	7	6	5	4	3	2	1	0
Name	PHSn_V7	PHSn_V6	PHSn_V5	PHSn_V4	PHSn_V3	PHSn_V2	PHSn_V1	PHSn_V0
R/W	R/W	R/W	R/W	R/W	R/W	R/W	R/W	R/W
POR	0	0	0	0	0	0	0	0

Bit 7~0 **PHSn_V7~PHSn_V0**: V_{COM} LUT Phase n repeats times selection

- 00000000: 0
- 00000001: 1
- 00000010: 2
- 00000011: 3
- :
- 11111111: 255

If PHSn_V7~PHSn_V0 bits are set to “00000000”, the Phase n and later phases will have no waveform output, These phases output are all V_{SS} level even if those groups have setting values.

For example, when PHS1_V7~PHS1_V0 bits are set to “00000000”, the Phase 1 has repeat times of 0. The Phase 1~4 have no waveform output, these phases output are all V_{SS} level.

When PHS2_V7~PHS2_V0 bits are set to “00000000”, the Phase 2 has repeat times of 0, The Phase 2~4 have no waveform output, these phases output are all V_{SS} level.

• **LVLn_KK1 Register (n=0~4)**

Bit	7	6	5	4	3	2	1	0
Name	LVLn_KK11	LVLn_KK10	FRMn_KK15	FRMn_KK14	FRMn_KK13	FRMn_KK12	FRMn_KK11	FRMn_KK10
R/W	R/W	R/W	R/W	R/W	R/W	R/W	R/W	R/W
POR	0	0	0	0	0	0	0	0

Bit 7~6 **LVLn_KK11~LVLn_KK10**: BlackBlack LUT Phase n voltage Level 1 selection

00: V_{DL}
01: V_{DH}
10: 0V
11: Floating

Bit 5~0 **FRMn_KK15~FRMn_KK10**: BlackBlack LUT Phase n frame 1 number selection

000000: 0
000001: 1
:
111111: 63

If FRMn_KK1[5:0] and FRMn_KK2[5:0] bits are both set to “000000”, the Phase n and later phases will have no waveform output, These phases output are all V_{SS} level even if those groups have setting values.

For example, when FRM2_KK1[5:0] and FRM2_KK2[5:0] bits are both set to “000000”, the Phase 2 frame number is 0. The Phase 2~4 have no waveform output, these phases output are all V_{SS} level.

• **LVLn_KK2 Register (n=0~4)**

Bit	7	6	5	4	3	2	1	0
Name	LVLn_KK21	LVLn_KK20	FRMn_KK25	FRMn_KK24	FRMn_KK23	FRMn_KK22	FRMn_KK21	FRMn_KK20
R/W	R/W	R/W	R/W	R/W	R/W	R/W	R/W	R/W
POR	1	1	1	1	1	1	1	1

Bit 7~6 **LVLn_KK21~LVLn_KK20**: BlackBlack LUT Phase n voltage Level 2 selection

00: V_{DL}
01: V_{DH}
10: 0V
11: Floating

Bit 5~0 **FRMn_KK25~FRMn_KK20**: BlackBlack LUT Phase n frame 2 number selection

000000: 0
000001: 1
:
111111: 63

If FRMn_KK1[5:0] and FRMn_KK2[5:0] bits are both set to “000000”, the Phase n and later phases will have no waveform output, These phases output are all V_{SS} level even if those groups have setting values.

For example, when FRM2_KK1[5:0] and FRM2_KK2[5:0] bits are both set to “000000”, the Phase 2 frame number is 0. The Phase 2~4 have no waveform output, these phases output are all V_{SS} level.

• PHSn_KK Register (n=0~4)

Bit	7	6	5	4	3	2	1	0
Name	PHSn_KK7	PHSn_KK6	PHSn_KK5	PHSn_KK4	PHSn_KK3	PHSn_KK2	PHSn_KK1	PHSn_KK0
R/W	R/W	R/W	R/W	R/W	R/W	R/W	R/W	R/W
POR	0	0	0	0	0	0	0	0

Bit 7~0 **PHSn_KK7~PHSn_KK0**: BlackBlack LUT Phase n repeats times selection

00000000: 0

00000001: 1

00000010: 2

00000011: 3

:

11111111: 255

If PHSn_KK7~PHSn_KK0 bits are set to “00000000”, the Phase n and later phases will have no waveform output, These phases output are all V_{SS} level even if those groups have setting values.

For example, when PHS1_KK7~PHS1_KK0 bits are set to “00000000”, the Phase 1 has repeat times of 0. The Phase 1~4 have no waveform output, these phases output are all V_{SS} level.

When PHS2_KK7~PHS2_KK0 bits are set to “00000000”, the Phase 2 has repeat times of 0, The Phase 2~4 have no waveform output, these phases output are all V_{SS} level.

• LVLn_KW1 Register (n=0~4)

Bit	7	6	5	4	3	2	1	0
Name	LVLn_KW11	LVLn_KW10	FRMn_KW15	FRMn_KW14	FRMn_KW13	FRMn_KW12	FRMn_KW11	FRMn_KW10
R/W	R/W	R/W	R/W	R/W	R/W	R/W	R/W	R/W
POR	0	0	0	0	0	0	0	0

Bit 7~6 **LVLn_KW11~LVLn_KW10**: BlackWhite LUT Phase n voltage Level 1 selection

00: V_{DL}

01: V_{DH}

10: 0V

11: Floating

Bit 5~0 **FRMn_KW15~FRMn_KW10**: BlackWhite LUT Phase n frame 1 number selection

000000: 0

000001: 1

:

111111: 63

If FRMn_KW1[5:0] and FRMn_KW2[5:0] bits are both set to “000000”, the Phase n and later phases will have no waveform output, These phases output are all V_{SS} level even if those groups have setting values.

For example, when FRM2_KW1[5:0] and FRM2_KW2[5:0] bits are both set to “000000”, the Phase 2 frame number is 0. The Phase 2~4 have no waveform output, these phases output are all V_{SS} level.

• **LVLn_KW2 Register (n=0~4)**

Bit	7	6	5	4	3	2	1	0
Name	LVLn_KW21	LVLn_KW20	FRMn_KW25	FRMn_KW24	FRMn_KW23	FRMn_KW22	FRMn_KW21	FRMn_KW20
R/W	R/W	R/W	R/W	R/W	R/W	R/W	R/W	R/W
POR	1	1	1	1	1	1	1	1

Bit 7~6 **LVLn_KW21~LVLn_KW20:** BlackWhite LUT Phase n voltage Level 2 selection

00: V_{DL}
01: V_{DH}
10: 0V
11: Floating

Bit 5~0 **FRMn_KW25~FRMn_KW20:** BlackWhite LUT Phase n frame 2 number selection

000000: 0
000001: 1
:
111111: 63

If FRMn_KW1[5:0] and FRMn_KW2[5:0] bits are both set to “000000”, the Phase n and later phases will have no waveform output, These phases output are all V_{SS} level even if those groups have setting values.

For example, when FRM2_KW1[5:0] and FRM2_KW2[5:0] bits are both set to “000000”, the Phase 2 frame number is 0. The Phase 2~4 have no waveform output, these phases output are all V_{SS} level.

• **PHSn_KW Register (n=0~4)**

Bit	7	6	5	4	3	2	1	0
Name	PHSn_KW7	PHSn_KW6	PHSn_KW5	PHSn_KW4	PHSn_KW3	PHSn_KW2	PHSn_KW1	PHSn_KW0
R/W	R/W	R/W	R/W	R/W	R/W	R/W	R/W	R/W
POR	0	0	0	0	0	0	0	0

Bit 7~0 **PHSn_KW7~PHSn_KW0:** BlackWhite LUT Phase n repeats times selection

00000000: 0
00000001: 1
00000010: 2
00000011: 3
:
11111111: 255

If PHSn_KW7~PHSn_KW0 bits are set to “00000000”, the Phase n and later phases will have no waveform output, These phases output are all V_{SS} level even if those groups have setting values.

For example, when PHS1_KW7~PHS1_KW0 bits are set to “00000000”, the Phase 1 has repeat times of 0. The Phase 1~4 have no waveform output, these phases output are all V_{SS} level.

When PHS2_KW7~PHS2_KW0 bits are set to “00000000”, the Phase 2 has repeat times of 0, The Phase 2~4 have no waveform output, these phases output are all V_{SS} level.

• **LVLn_WK1 Register (n=0~4)**

Bit	7	6	5	4	3	2	1	0
Name	LVLn_WK11	LVLn_WK10	FRMn_WK15	FRMn_WK14	FRMn_WK13	FRMn_WK12	FRMn_WK11	FRMn_WK10
R/W	R/W	R/W	R/W	R/W	R/W	R/W	R/W	R/W
POR	0	0	0	0	0	0	0	0

Bit 7~6 **LVLn_WK11~LVLn_WK10**: WhiteBlack LUT Phase n voltage Level 1 selection

00: V_{DL}
 01: V_{DH}
 10: 0V
 11: Floating

Bit 5~0 **FRMn_WK15~FRMn_WK10**: WhiteBlack LUT Phase n frame 1 number selection

000000: 0
 000001: 1
 :
 111111: 63

If FRMn_WK1[5:0] and FRMn_WK2[5:0] bits are both set to “000000”, the Phase n and later phases will have no waveform output, These phases output are all V_{SS} level even if those groups have setting values.

For example, when FRM2_WK1[5:0] and FRM2_WK2[5:0] bits are both set to “000000”, the Phase 2 frame number is 0. The Phase 2~4 have no waveform output, these phases output are all V_{SS} level.

• **LVLn_WK2 Register (n=0~4)**

Bit	7	6	5	4	3	2	1	0
Name	LVLn_WK21	LVLn_WK20	FRMn_WK25	FRMn_WK24	FRMn_WK23	FRMn_WK22	FRMn_WK21	FRMn_WK20
R/W	R/W	R/W	R/W	R/W	R/W	R/W	R/W	R/W
POR	1	1	1	1	1	1	1	1

Bit 7~6 **LVLn_WK21~LVLn_WK20**: WhiteBlack LUT Phase n voltage Level 2 selection

00: V_{DL}
 01: V_{DH}
 10: 0V
 11: Floating

Bit 5~0 **FRMn_WK25~FRMn_WK20**: WhiteBlack LUT Phase n frame 2 number selection

000000: 0
 000001: 1
 :
 111111: 63

If FRMn_WK1[5:0] and FRMn_WK2[5:0] bits are both set to “000000”, the Phase n and later phases will have no waveform output, These phases output are all V_{SS} level even if those groups have setting values.

For example, when FRM2_WK1[5:0] and FRM2_WK2[5:0] bits are both set to “000000”, the Phase 2 frame number is 0. The Phase 2~4 have no waveform output, these phases output are all V_{SS} level.

• **PHSn_WK Register (n=0~4)**

Bit	7	6	5	4	3	2	1	0
Name	PHSn_WK7	PHSn_WK6	PHSn_WK5	PHSn_WK4	PHSn_WK3	PHSn_WK2	PHSn_WK1	PHSn_WK0
R/W	R/W	R/W	R/W	R/W	R/W	R/W	R/W	R/W
POR	0	0	0	0	0	0	0	0

Bit 7~0 **PHSn_WK7~PHSn_WK0**: WhiteBlack LUT Phase n repeats times selection

00000000: 0

00000001: 1

00000010: 2

00000011: 3

:

11111111: 255

If PHSn_WK7~PHSn_WK0 bits are set to “00000000”, the Phase n and later phases will have no waveform output, These phases output are all V_{SS} level even if those groups have setting values.

For example, when PHS1_WK7~PHS1_WK0 bits are set to “00000000”, the Phase 1 has repeat times of 0. The Phase 1~4 have no waveform output, these phases output are all V_{SS} level.

When PHS2_WK7~PHS2_WK0 bits are set to “00000000”, the Phase 2 has repeat times of 0, The Phase 2~4 have no waveform output, these phases output are all V_{SS} level.

• **LVLn_WW1 Register (n=0~4)**

Bit	7	6	5	4	3	2	1	0
Name	LVLn_WW11	LVLn_WW10	FRMn_WW15	FRMn_WW14	FRMn_WW13	FRMn_WW12	FRMn_WW11	FRMn_WW10
R/W	R/W	R/W	R/W	R/W	R/W	R/W	R/W	R/W
POR	0	0	0	0	0	0	0	0

Bit 7~6 **LVLn_WW11~LVLn_WW10**: WhiteWhite LUT Phase n voltage Level 1 selection

00: V_{DL}

01: V_{DH}

10: 0V

11: Floating

Bit 5~0 **FRMn_WW15~FRMn_WW10**: WhiteWhite LUT Phase n frame 1 number selection

000000: 0

000001: 1

:

111111: 63

If FRMn_WW1[5:0] and FRMn_WW2[5:0] bits are both set to “000000”, the Phase n and later phases will have no waveform output, These phases output are all V_{SS} level even if those groups have setting values.

For example, when FRM2_WW1[5:0] and FRM2_WW2[5:0] bits are both set to “000000”, the Phase 2 frame number is 0. The Phase 2~4 have no waveform output, these phases output are all V_{SS} level.

• **LVLn_WW2 Register (n=0~4)**

Bit	7	6	5	4	3	2	1	0
Name	LVLn_WW21	LVLn_WW20	FRMn_WW25	FRMn_WW24	FRMn_WW23	FRMn_WW22	FRMn_WW21	FRMn_WW20
R/W	R/W	R/W	R/W	R/W	R/W	R/W	R/W	R/W
POR	1	1	1	1	1	1	1	1

Bit 7~6 **LVLn_WW21~LVLn_WW20**: WhiteWhite LUT Phase n voltage Level 2 selection
 00: V_{DL}
 01: V_{DH}
 10: 0V
 11: Floating

Bit 5~0 **FRMn_WW25~FRMn_WW20**: WhiteWhite LUT Phase n frame 2 number selection
 000000: 0
 000001: 1
 :
 111111: 63

If FRMn_WW1[5:0] and FRMn_WW2[5:0] bits are both set to “000000”, the Phase n and later phases will have no waveform output, These phases output are all V_{SS} level even if those groups have setting values.

For example, when FRM2_WW1[5:0] and FRM2_WW2[5:0] bits are both set to “000000”, the Phase 2 frame number is 0. The Phase 2~4 have no waveform output, these phases output are all V_{SS} level.

• **PHSn_WW Register (n=0~4)**

Bit	7	6	5	4	3	2	1	0
Name	PHSn_WW7	PHSn_WW6	PHSn_WW5	PHSn_WW4	PHSn_WW3	PHSn_WW2	PHSn_WW1	PHSn_WW0
R/W	R/W	R/W	R/W	R/W	R/W	R/W	R/W	R/W
POR	0	0	0	0	0	0	0	0

Bit 7~0 **PHSn_WW7~PHSn_WW0**: WhiteWhite LUT Phase n repeats times selection
 00000000: 0
 00000001: 1
 00000010: 2
 00000011: 3
 :
 11111111: 255

If PHSn_WW7~PHSn_WW0 bits are set to “00000000”, the Phase n and later phases will have no waveform output, These phases output are all V_{SS} level even if those groups have setting values.

For example, when PHS1_WW7~PHS1_WW0 bits are set to “00000000”, the Phase 1 has repeat times of 0. The Phase 1~4 have no waveform output, these phases output are all V_{SS} level.

When PHS2_WW7~PHS2_WW0 bits are set to “00000000”, the Phase 2 has repeat times of 0, The Phase 2~4 have no waveform output, these phases output are all V_{SS} level.

EPD Driver Voltage Source and Biasing

The EPD function power is sourced from external AVDD and EVSS pins and Common, Background and Segment pins are driving by internal charge pump output voltage. The charge pump used two external capacitor to pump voltage, the VDHO and VDLO pins output the pump voltage while the VDHI, VDLI pins input the voltage to Common, Background and Segment pins, which are used for driver electrical paper. The users can use the VDH_LV and VDL_LV registers to control VDHO, VDLO pins output voltage respectively.

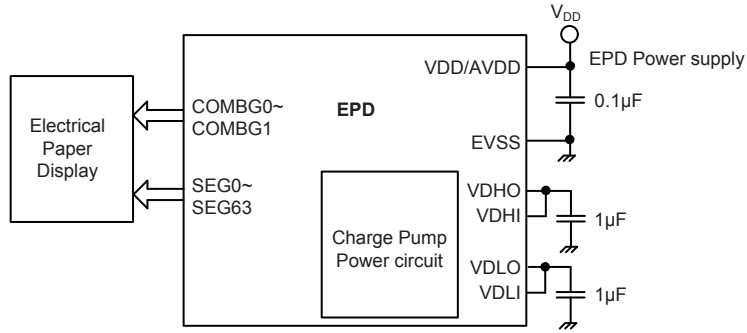

EPD Driver Output Waveforms

The device provides the Look-Up Table (LUT) for EPD driver function to driving electronic paper. Users can use V_{COM} LUT (LUTV) registers, BlackBlack LUT (LUT_KK) registers, BlackWhite LUT (LUT_KW) registers, WhiteBlack LUT (LUT_WK) registers and WhiteWhite LUT (LUT_WW) registers to control Common, Background and Segment pins output.

The following example shows the relationships between LUT registers setting and output waveform.

Look up Table	Phase 0			Phase 1			Phase 2			Phase 3			Phase 4		
LUTV (COM)	05h	05h	01h	0Ah	0Ah	01h	85h	45h	03h	05h	05h	01h	05h	05h	01h
LUT_KK (SEG)	05h	05h	01h	8Ah	0Ah	01h	45h	85h	03h	05h	05h	01h	45h	45h	01h
LUT_KW (SEG)	45h	45h	01h	0Ah	0Ah	01h	45h	85h	03h	85h	85h	01h	85h	85h	01h
LUT_WK (SEG)	85h	85h	01h	8Ah	0Ah	01h	45h	85h	03h	45h	45h	01h	45h	45h	01h
LUT_WW (SEG)	85h	85h	01h	0Ah	8Ah	01h	45h	85h	03h	05h	05h	01h	85h	85h	01h

According to the LUT registers setting, the output waveforms are shown as below.

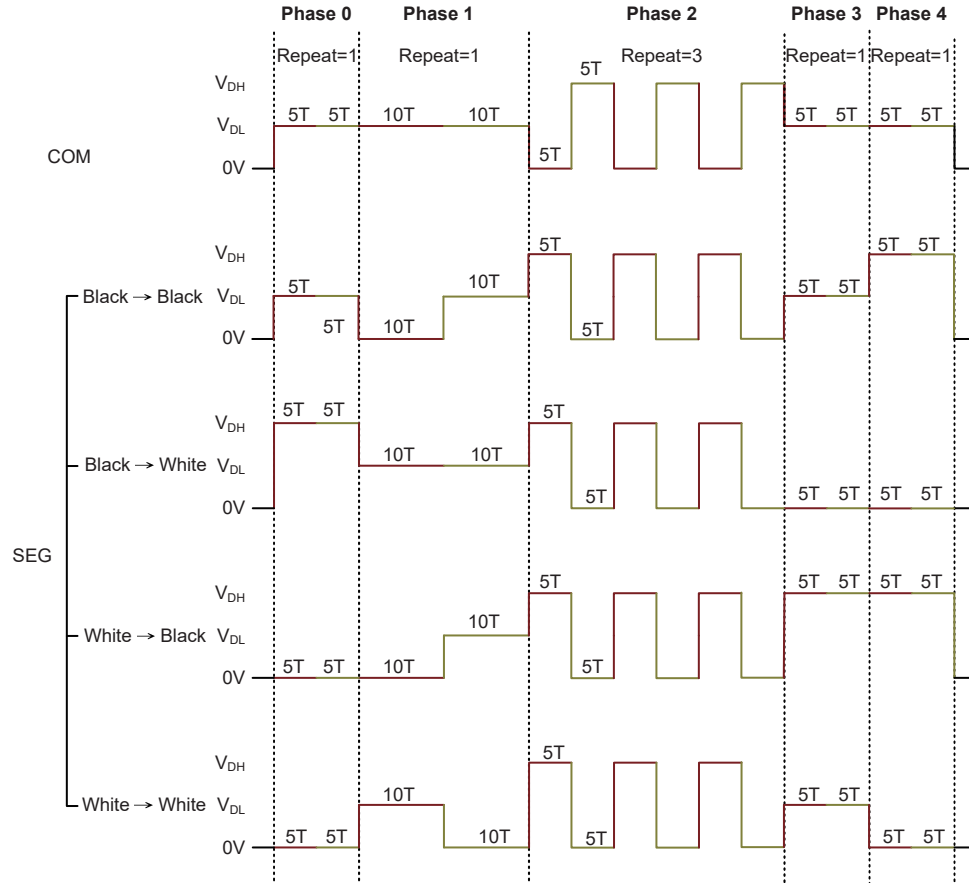

Note: 1. $T=1/f$, the parameter is setting by P0~P2 bits in the EPDC2 register.
 2. The Background the same to SEG waveform is controlled by LUT table.

Universal Serial Interface Module – USIM

The device contains a Universal Serial Interface Module, which includes the four-line SPI interface, the two-line I²C interface and the two-line UART interface types, to allow an easy method of communication with external peripheral hardware. Having relatively simple communication protocols, these serial interface types allow the microcontroller to interface to external SPI, I²C or UART based hardware such as sensors, Flash or EEPROM memory, etc. The USIM interface pins are pin-shared with other I/O pins therefore the USIM interface functional pins must first be selected using the corresponding pin-shared function selection bits. As all the interface types share the same pins and registers, the choice of whether the UART, SPI or I²C type is used is made using the UART mode selection bit, named UMD, and the SPI/I²C operating mode control bits, named SIM2~SIM0, in the SIMC0 register. These pull-high resistors of the USIM pin-shared I/O are selected using pull-high control registers when the USIM function is enabled and the corresponding pins are used as USIM input pins.

SPI Interface

This SPI interface function, which is part of the Universal Serial Interface Module, should not be confused with the other independent SPI function, which is described in another section of this datasheet.

The SPI interface is often used to communicate with external peripheral devices such as sensors, Flash or EEPROM memory devices etc. Originally developed by Motorola, the four line SPI interface is a synchronous serial data interface that has a relatively simple communication protocol simplifying the programming requirements when communicating with external hardware devices.

The communication is full duplex and operates as a slave/master type, where the device can be either master or slave. Although the SPI interface specification can control multiple slave devices from a single master, but the device provides only one $\overline{\text{SCS}}$ pin. If the master needs to control multiple slave devices from a single master, the master can use I/O pin to select the slave devices.

SPI Interface Operation

The SPI interface is a full duplex synchronous serial data link. It is a four line interface with pin names SDI, SDO, SCK and $\overline{\text{SCS}}$. Pins SDI and SDO are the Serial Data Input and Serial Data Output lines, the SCK pin is the Serial Clock line and $\overline{\text{SCS}}$ is the Slave Select line. As the SPI interface pins are pin-shared with normal I/O pins and with the I²C/UART function pins, the SPI interface pins must first be selected by configuring the pin-shared function selection bits and setting the correct bits in the SIMC0 and SIMC2 registers. Communication between devices connected to the SPI interface is carried out in a slave/master mode with all data transfer initiations being implemented by the master. The Master also controls the clock signal. As the device only contains a single $\overline{\text{SCS}}$ pin only one slave device can be utilized. The $\overline{\text{SCS}}$ pin is controlled by software, set CSEN bit to 1 to enable $\overline{\text{SCS}}$ pin function, set CSEN bit to 0 the $\overline{\text{SCS}}$ pin will be floating state.

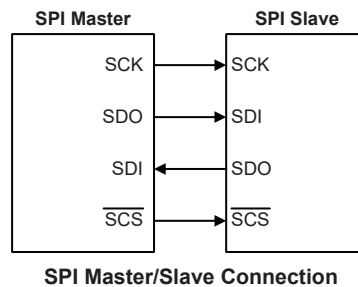

The SPI function in the device offers the following features:

- Full duplex synchronous data transfer
- Both Master and Slave modes
- LSB first or MSB first data transmission modes
- Transmission complete flag
- Rising or falling active clock edge

The status of the SPI interface pins is determined by a number of factors such as whether the device is in the master or slave mode and upon the condition of certain control bits such as CSEN and SIMEN.

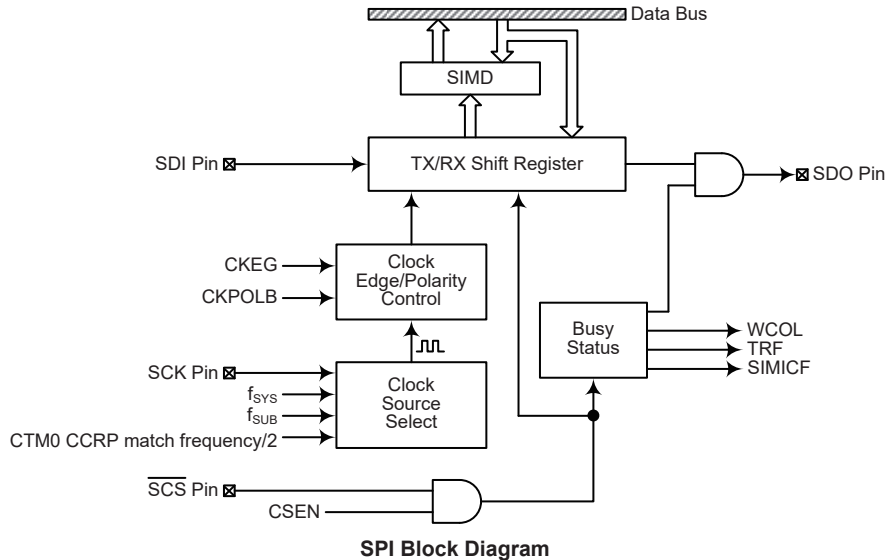

SPI Registers

There are three internal registers which control the overall operation of the SPI interface. These are the SIMD data register and two control registers, SIMC0 and SIMC2. Note that the SIMC2 and SIMD registers and their POR values are only available when the SPI mode is selected by properly configuring the UMD and SIM2~SIM0 bits in the SIMC0 register.

Register Name	Bit							
	7	6	5	4	3	2	1	0
SIMC0	SIM2	SIM1	SIM0	UMD	SIMDEB1	SIMDEB0	SIMEN	SIMICF
SIMC2	D7	D6	CKPOLB	CKEG	MLS	CSEN	WCOL	TRF
SIMD	D7	D6	D5	D4	D3	D2	D1	D0

SPI Register List

SPI Data Register

The SIMD register is used to store the data being transmitted and received. The same register is used by both the SPI and I²C functions. Before the device writes data to the SPI bus, the actual data to be transmitted must be placed in the SIMD register. After the data is received from the SPI bus, the device can read it from the SIMD register. Any transmission or reception of data from the SPI bus must be made via the SIMD register.

• **SIMD Register**

Bit	7	6	5	4	3	2	1	0
Name	D7	D6	D5	D4	D3	D2	D1	D0
R/W	R/W	R/W	R/W	R/W	R/W	R/W	R/W	R/W
POR	x	x	x	x	x	x	x	x

“x”: unknown

Bit 7~0 **D7~D0**: USIM SPI/I²C data register bit 7~bit 0

SPI Control Registers

There are also two control registers for the SPI interface, SIMC0 and SIMC2. The SIMC0 register is used to control the enable/disable function and to set the data transmission clock frequency. The SIMC2 register is used for other control functions such as LSB/MSB selection, write collision flag etc.

• **SIMC0 Register**

Bit	7	6	5	4	3	2	1	0
Name	SIM2	SIM1	SIM0	UMD	SIMDEB1	SIMDEB0	SIMEN	SIMICF
R/W	R/W	R/W	R/W	R/W	R/W	R/W	R/W	R/W
POR	1	1	1	0	0	0	0	0

Bit 7~5 **SIM2~SIM0**: USIM SPI/I²C Operating Mode Control

- 000: SPI master mode; SPI clock is $f_{SYS}/4$
- 001: SPI master mode; SPI clock is $f_{SYS}/16$
- 010: SPI master mode; SPI clock is $f_{SYS}/64$
- 011: SPI master mode; SPI clock is f_{SUB}
- 100: SPI master mode; SPI clock is CTM0 CCRP match frequency/2
- 101: SPI slave mode
- 110: I²C slave mode
- 111: Unused mode

When the UMD bit is cleared to zero, these bits setup the SPI or I²C operating mode of the USIM function. As well as selecting if the I²C or SPI function, they are used to control the SPI Master/Slave selection and the SPI Master clock frequency. The SPI clock is a function of the system clock but can also be chosen to be sourced from CTM0 and f_{SUB} . If the SPI Slave Mode is selected then the clock will be supplied by an external Master device.

Bit 4 **UMD**: UART mode selection bit

- 0: SPI or I²C mode
- 1: UART mode

This bit is used to select the UART mode. When this bit is cleared to zero, the actual SPI or I²C mode can be selected using the SIM2~SIM0 bits. Note that the UMD bit must be set low for SPI or I²C mode.

Bit 3~2 **SIMDEB1~SIMDEB0**: I²C Debounce Time Selection

These bits are only available when the USIM is configured to operate in the I²C mode. Refer to the I²C register section.

Bit 1 **SIMEN**: USIM SPI/I²C Enable Control

- 0: Disable
- 1: Enable

The bit is the overall on/off control for the USIM SPI/I²C interface. When the SIMEN bit is cleared to zero to disable the USIM SPI/I²C interface, the \overline{SDI} , \overline{SDO} , \overline{SCK} and \overline{SCS} , or \overline{SDA} and \overline{SCL} lines will lose their SPI or I²C function and the USIM operating current will be reduced to a minimum value. When the bit is high the USIM SPI/I²C interface is enabled. If the USIM is configured to operate as an SPI interface via the UMD and SIM2~SIM0 bits, the contents of the SPI control registers will remain at the

previous settings when the SIMEN bit changes from low to high and should therefore be first initialised by the application program. If the USIM is configured to operate as an I²C interface via the UMD and SIM2~SIM0 bits and the SIMEN bit changes from low to high, the contents of the I²C control bits such as HTX and TXAK will remain at the previous settings and should therefore be first initialised by the application program while the relevant I²C flags such as HCF, HAAS, HBB, SRW and RXAK will be set to their default states.

- Bit 0 **SIMICF**: USIM SPI Incomplete Flag
 0: USIM SPI incomplete condition is not occurred
 1: USIM SPI incomplete condition is occurred

This bit is only available when the USIM is configured to operate in an SPI slave mode. If the SPI operates in the slave mode with the SIMEN and CSEN bits both being set high but the SCS line is pulled high by the external master device before the SPI data transfer is completely finished, the SIMICF bit will be set high together with the TRF bit. When this condition occurs, the corresponding interrupt will occur if the interrupt function is enabled. However, the TRF bit will not be set high if the SIMICF bit is set high by software application program.

• **SIMC2 Register**

Bit	7	6	5	4	3	2	1	0
Name	D7	D6	CKPOLB	CKEG	MLS	CSEN	WCOL	TRF
R/W	R/W	R/W	R/W	R/W	R/W	R/W	R/W	R/W
POR	0	0	0	0	0	0	0	0

- Bit 7~6 **D7~D6**: Undefined bits
 These bits can be read or written by the application program.

- Bit 5 **CKPOLB**: SPI clock line base condition selection
 0: The SCK line will be high when the clock is inactive
 1: The SCK line will be low when the clock is inactive
 The CKPOLB bit determines the base condition of the clock line, if the bit is high, then the SCK line will be low when the clock is inactive. When the CKPOLB bit is low, then the SCK line will be high when the clock is inactive.

- Bit 4 **CKEG**: SPI SCK clock active edge type selection
 CKPOLB=0
 0: SCK is high base level and data capture at SCK rising edge
 1: SCK is high base level and data capture at SCK falling edge
 CKPOLB=1
 0: SCK is low base level and data capture at SCK falling edge
 1: SCK is low base level and data capture at SCK rising edge

The CKEG and CKPOLB bits are used to setup the way that the clock signal outputs and inputs data on the SPI bus. These two bits must be configured before data transfer is executed otherwise an erroneous clock edge may be generated. The CKPOLB bit determines the base condition of the clock line, if the bit is high, then the SCK line will be low when the clock is inactive. When the CKPOLB bit is low, then the SCK line will be high when the clock is inactive. The CKEG bit determines active clock edge type which depends upon the condition of CKPOLB bit.

- Bit 3 **MLS**: SPI data shift order
 0: LSB first
 1: MSB first
 This is the data shift select bit and is used to select how the data is transferred, either MSB or LSB first. Setting the bit high will select MSB first and low for LSB first.

- Bit 2 **CSEN**: SPI $\overline{\text{SCS}}$ pin control
 0: Disable
 1: Enable
 The CSEN bit is used as an enable/disable for the $\overline{\text{SCS}}$ pin. If this bit is low, then the $\overline{\text{SCS}}$ pin will be disabled and placed into a floating condition. If the bit is high the SCS pin will be enabled and used as a select pin.
- Bit 1 **WCOL**: SPI write collision flag
 0: No collision
 1: Collision
 The WCOL flag is used to detect if a data collision has occurred. If this bit is high it means that data has been attempted to be written to the SIMD register during a data transfer operation. This writing operation will be ignored if data is being transferred. The bit can be cleared to zero by the application program.
- Bit 0 **TRF**: SPI Transmit/Receive complete flag
 0: SPI data is being transferred
 1: SPI data transmission is completed
 The TRF bit is the Transmit/Receive Complete flag and is set “1” automatically when an SPI data transmission is completed, but must set to “0” by the application program. It can be used to generate an interrupt.

SPI Communication

After the SPI interface is enabled by setting the SIMEN bit high, then in the Master Mode, when data is written to the SIMD register, transmission/reception will begin simultaneously. When the data transfer is completed, the TRF flag will be set high automatically, but must be cleared using the application program. In the Slave Mode, when the clock signal from the master has been received, any data in the SIMD register will be transmitted and any data on the SDI pin will be shifted into the SIMD register. The master should output an $\overline{\text{SCS}}$ signal to enable the slave devices before a clock signal is provided. The slave data to be transferred should be well prepared at the appropriate moment relative to the SCK signal depending upon the configurations of the CKPOLB bit and CKEG bit. The accompanying timing diagram shows the relationship between the slave data and SCK signal for various configurations of the CKPOLB and CKEG bits.

The SPI will continue to function in certain IDLE Modes if the clock source used by the SPI interface is still active.

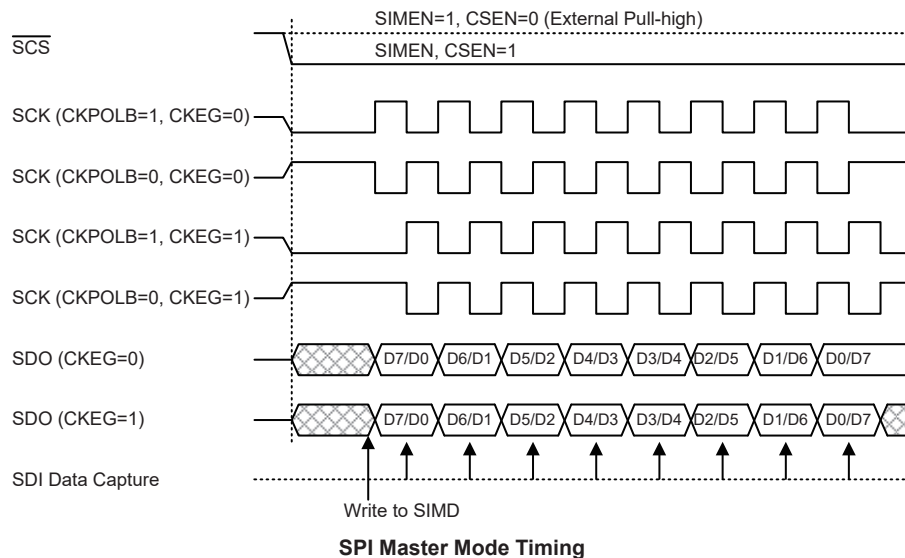

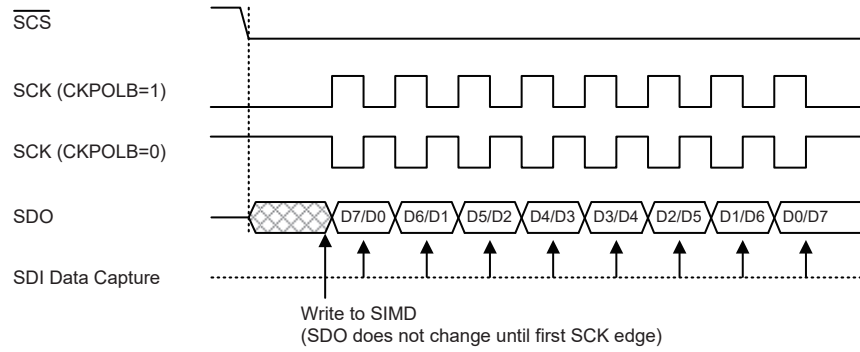

SPI Slave Mode Timing – CKEG=0

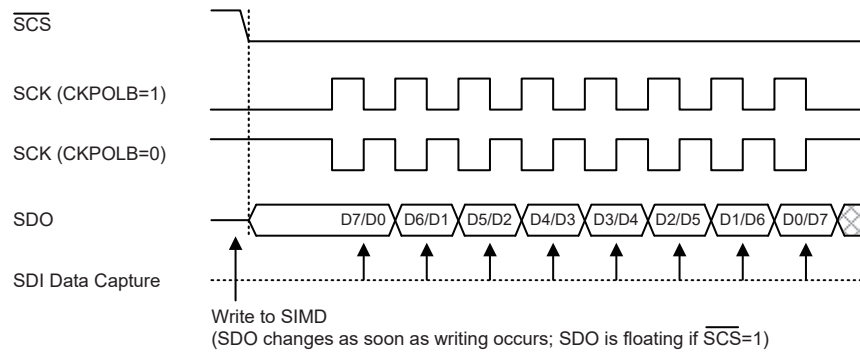

Note: For SPI slave mode, if $\overline{SIMEN}=1$ and $CSEN=0$, SPI is always enabled and ignores the \overline{SCS} level.

SPI Slave Mode Timing – CKEG=1

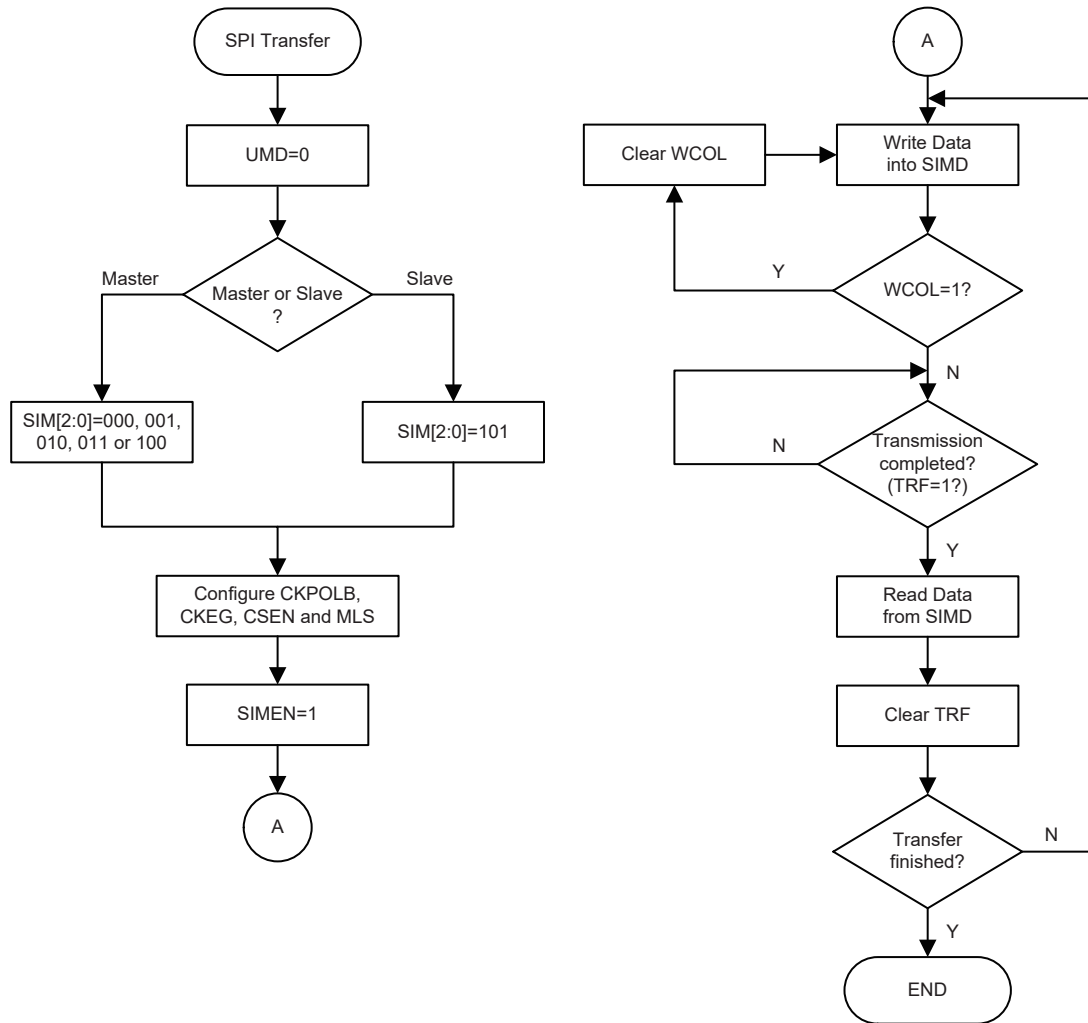

SPI Transfer Control Flow Chart

SPI Bus Enable/Disable

To enable the SPI bus, set CSEN=1 and \overline{SCS} =0, then wait for data to be written into the SIMD (TXRX buffer) register. For the Master Mode, after data has been written to the SIMD (TXRX buffer) register, then transmission or reception will start automatically. When all the data has been transferred, the TRF bit should be set. For the Slave Mode, when clock pulses are received on SCK, data in the TXRX buffer will be shifted out or data on SDI will be shifted in.

When the SPI bus is disabled, SCK, SDI, SDO and \overline{SCS} can become I/O pins or other pin-shared functions using the corresponding pin-shared control bits.

SPI Operation Steps

All communication is carried out using the 4-line interface for either Master or Slave Mode.

The CSEN bit in the SIMC2 register controls the overall function of the SPI interface. Setting this bit high will enable the SPI interface by allowing the \overline{SCS} line to be active, which can then be used to control the SPI interface. If the CSEN bit is low, the SPI interface will be disabled and the \overline{SCS} line will be in a floating condition and can therefore not be used for control of the SPI interface. If the CSEN bit and the SIMEN bit in the SIMC0 are set high, this will place the SDI line in a

floating condition and the SDO line high. If in Master Mode the SCK line will be either high or low depending upon the clock polarity selection bit CKPOLB in the SIMC2 register. If in Slave Mode the SCK line will be in a floating condition. If the SIMEN bit is low, then the bus will be disabled and $\overline{\text{SCS}}$, SDI, SDO and SCK will all become I/O pins or the other functions using the corresponding pin-shared control bits. In the Master Mode the Master will always generate the clock signal. The clock and data transmission will be initiated after data has been written into the SIMD register. In the Slave Mode, the clock signal will be received from an external master device for both data transmission and reception. The following sequences show the order to be followed for data transfer in both Master and Slave Mode.

Master Mode

- Step 1
Select the SPI Master mode and clock source using the UMD and SIM2~SIM0 bits in the SIMC0 control register.
- Step 2
Setup the CSEN bit and setup the MLS bit to choose if the data is MSB or LSB first, this setting must be the same with the Slave devices.
- Step 3
Setup the SIMEN bit in the SIMC0 control register to enable the SPI interface.
- Step 4
For write operations: write the data to the SIMD register, which will actually place the data into the TXRX buffer. Then use the SCK and $\overline{\text{SCS}}$ lines to output the data. After this, go to step 5.
For read operations: the data transferred in on the SDI line will be stored in the TXRX buffer until all the data has been received at which point it will be latched into the SIMD register.
- Step 5
Check the WCOL bit if set high then a collision error has occurred so return to step 4. If equal to zero then go to the following step.
- Step 6
Check the TRF bit or wait for a USIM SPI serial bus interrupt.
- Step 7
Read data from the SIMD register.
- Step 8
Clear TRF.
- Step 9
Go to step 4.

Slave Mode

- Step 1
Select the SPI Slave mode using the UMD and SIM2~SIM0 bits in the SIMC0 control register.
- Step 2
Setup the CSEN bit and setup the MLS bit to choose if the data is MSB or LSB first, this setting must be the same with the Master devices.
- Step 3
Setup the SIMEN bit in the SIMC0 control register to enable the SPI interface.
- Step 4
For write operations: write the data to the SIMD register, which will actually place the data into the TXRX buffer. Then wait for the master clock SCK and $\overline{\text{SCS}}$ signal. After this, go to step 5.

For read operations: the data transferred in on the SDI line will be stored in the TXRX buffer until all the data has been received at which point it will be latched into the SIMD register.

- Step 5
Check the WCOL bit if set high then a collision error has occurred so return to step 4. If equal to zero then go to the following step.
- Step 6
Check the TRF bit or wait for a USIM SPI serial bus interrupt.
- Step 7
Read data from the SIMD register.
- Step 8
Clear TRF.
- Step 9
Go to step 4.

Error Detection

The WCOL bit in the SIMC2 register is provided to indicate errors during data transfer. The bit is set by the SPI serial Interface but must be cleared by the application program. This bit indicates that a data collision has occurred which happens if a write to the SIMD register takes place during a data transfer operation and will prevent the write operation from continuing.

I²C Interface

The I²C interface is used to communicate with external peripheral devices such as sensors, EEPROM memory etc. Originally developed by Philips, it is a two line low speed serial interface for synchronous serial data transfer. The advantage of only two lines for communication, relatively simple communication protocol and the ability to accommodate multiple devices on the same bus has made it an extremely popular interface type for many applications.

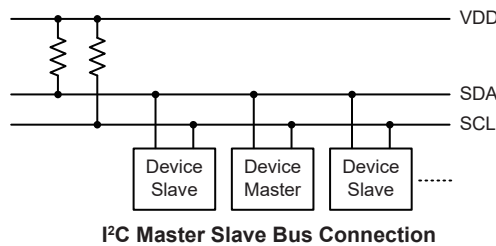

I²C Interface Operation

The I²C serial interface is a two line interface, a serial data line, SDA, and serial clock line, SCL. As many devices may be connected together on the same bus, their outputs are both open drain types. For this reason it is necessary that external pull-high resistors are connected to these outputs. Note that no chip select line exists, as each device on the I²C bus is identified by a unique address which will be transmitted and received on the I²C bus.

When two devices communicate with each other on the bidirectional I²C bus, one is known as the master device and one as the slave device. Both master and slave can transmit and receive data, however, it is the master device that has overall control of the bus. For the device, which only operates in slave mode, there are two methods of transferring data on the I²C bus, the slave transmit mode and the slave receive mode. The pull-high control function pin-shared with SCL/SDA pin is still applicable even if I²C device is activated and the related internal pull-high register could be controlled by its corresponding pull-high control register.

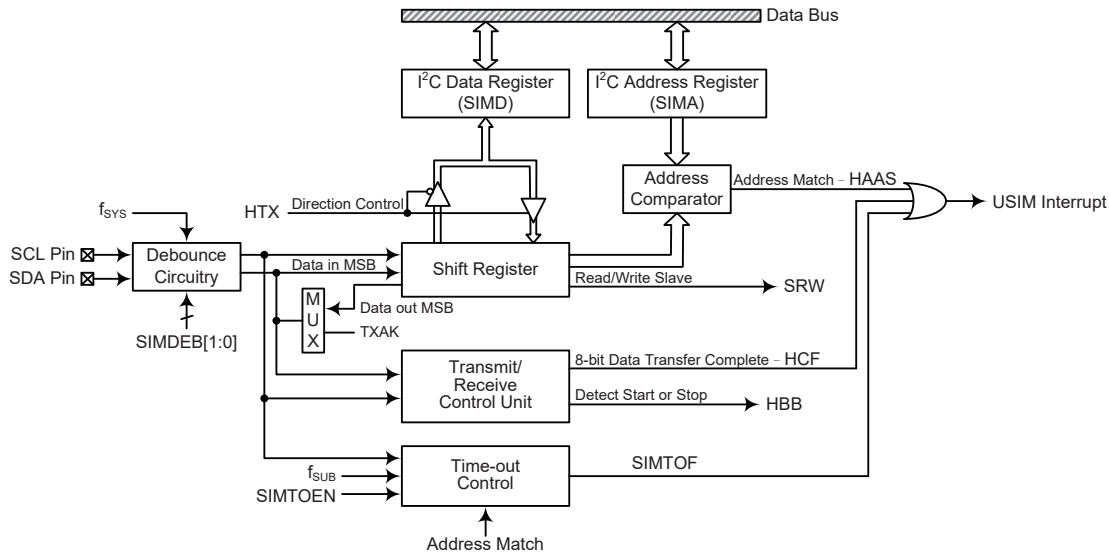

I²C Block Diagram

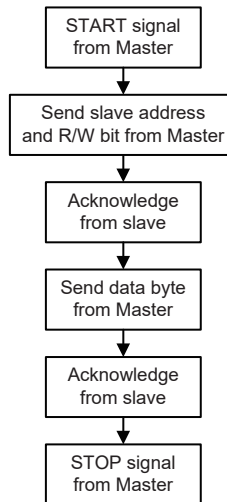

I²C Interface Operation

The SIMDEB1 and SIMDEB0 bits determine the debounce time of the I²C interface. This uses the internal clock to in effect add a debounce time to the external clock to reduce the possibility of glitches on the clock line causing erroneous operation. The debounce time, if selected, can be chosen to be either 2 or 4 system clocks. To achieve the required I²C data transfer speed, there exists a relationship between the system clock, f_{SYS} , and the I²C debounce time. For either the I²C Standard or Fast mode operation, users must take care of the selected system clock frequency and the configured debounce time to match the criterion shown in the following table.

I ² C Debounce Time Selection	I ² C Standard Mode (100kHz)	I ² C Fast Mode (400kHz)
2 system clock debounce	$f_{SYS} > 4\text{MHz}$	$f_{SYS} > 10\text{MHz}$
4 system clock debounce	$f_{SYS} > 8\text{MHz}$	$f_{SYS} > 20\text{MHz}$

I²C Minimum f_{SYS} Frequency Requirements

I²C Registers

There are three control registers associated with the I²C bus, SIMC0, SIMC1 and SIMTOC, one address register SIMA and one data register, SIMD. Note that the SIMC1, SIMD, SIMA and SIMTOC registers and their POR values are only available when the I²C mode is selected by properly configuring the UMD and SIM2~SIM0 bits in the SIMC0 register.

Register Name	Bit							
	7	6	5	4	3	2	1	0
SIMC0	SIM2	SIM1	SIM0	UMD	SIMDEB1	SIMDEB0	SIMEN	SIMICF
SIMC1	HCF	HAAS	HBB	HTX	TXAK	SRW	IAMWU	RXAK
SIMD	D7	D6	D5	D4	D3	D2	D1	D0
SIMA	SIMA6	SIMA5	SIMA4	SIMA3	SIMA2	SIMA1	SIMA0	D0
SIMTOC	SIMTOEN	SIMTOF	SIMTOS5	SIMTOS4	SIMTOS3	SIMTOS2	SIMTOS1	SIMTOS0

I²C Register List

I²C Data Register

The SIMD register is used to store the data being transmitted and received. The same register is used by both the SPI and I²C functions. Before the device writes data to the I²C bus, the actual data to be transmitted must be placed in the SIMD register. After the data is received from the I²C bus, the device can read it from the SIMD register. Any transmission or reception of data from the I²C bus must be made via the SIMD register.

• SIMD Register

Bit	7	6	5	4	3	2	1	0
Name	D7	D6	D5	D4	D3	D2	D1	D0
R/W	R/W	R/W	R/W	R/W	R/W	R/W	R/W	R/W
POR	x	x	x	x	x	x	x	x

"x": unknown

Bit 7~0 **D7~D0**: USIM SPI/I²C data register bit 7~bit 0

I²C Address Register

The SIMA register is also used by the SPI interface but has the name SIMC2. The SIMA register is the location where the 7-bit slave address of the slave device is stored. Bits 7~1 of the SIMA register define the device slave address. Bit 0 is not defined. When a master device, which is connected to the I²C bus, sends out an address, which matches the slave address in the SIMA register, the slave device will be selected.

• SIMA Register

Bit	7	6	5	4	3	2	1	0
Name	SIMA6	SIMA5	SIMA4	SIMA3	SIMA2	SIMA1	SIMA0	D0
R/W	R/W	R/W	R/W	R/W	R/W	R/W	R/W	R/W
POR	0	0	0	0	0	0	0	0

Bit 7~1 **SIMA6~SIMA0**: I²C slave address
SIMA6~SIMA0 is the I²C slave address bit 6~bit 0.

Bit 0 **D0**: Reserved bit, can be read or written

I²C Control Registers

There are three control registers for the I²C interface, SIMC0, SIMC1 and SIMTOC. The SIMC0 register is used to control the enable/disable function and to set the data transmission clock frequency. The SIMC1 register contains the relevant flags which are used to indicate the I²C communication status. Another register, SIMTOC, is used to control the I²C time-out function and is described in the corresponding section.

• SIMC0 Register

Bit	7	6	5	4	3	2	1	0
Name	SIM2	SIM1	SIM0	UMD	SIMDEB1	SIMDEB0	SIMEN	SIMICF
R/W	R/W	R/W	R/W	R/W	R/W	R/W	R/W	R/W
POR	1	1	1	0	0	0	0	0

Bit 7~5 **SIM2~SIM0**: USIM SPI/I²C Operating Mode Control
 000: SPI master mode; SPI clock is $f_{SYS}/4$
 001: SPI master mode; SPI clock is $f_{SYS}/16$
 010: SPI master mode; SPI clock is $f_{SYS}/64$
 011: SPI master mode; SPI clock is f_{SUB}
 100: SPI master mode; SPI clock is CTM0 CCRP match frequency/2
 101: SPI slave mode
 110: I²C slave mode
 111: Unused mode

When the UMD bit is cleared to zero, these bits setup the SPI or I²C operating mode of the USIM function. As well as selecting if the I²C or SPI function, they are used to control the SPI Master/Slave selection and the SPI Master clock frequency. The SPI clock is a function of the system clock but can also be chosen to be sourced from CTM0 and f_{SUB} . If the SPI Slave Mode is selected then the clock will be supplied by an external Master device.

Bit 4 **UMD**: UART mode selection bit
 0: SPI or I²C mode
 1: UART mode

This bit is used to select the UART mode. When this bit is cleared to zero, the actual SPI or I²C mode can be selected using the SIM2~SIM0 bits. Note that the UMD bit must be set low for SPI or I²C mode.

Bit 3~2 **SIMDEB1~SIMDEB0**: I²C Debounce Time Selection
 00: Undefined
 01: 2 system clock debounce
 1x: 4 system clock debounce

These bits are used to select the I²C debounce time when the USIM is configured as the I²C interface function by setting the UMD bit to “0” and SIM2~SIM0 bits to “110”.

Bit 1 **SIMEN**: USIM SPI/I²C Enable Control
 0: Disable
 1: Enable

The bit is the overall on/off control for the USIM SPI/I²C interface. When the SIMEN bit is cleared to zero to disable the USIM SPI/I²C interface, the SDI, SDO, SCK and SCS, or SDA and SCL lines will lose their SPI or I²C function and the USIM operating current will be reduced to a minimum value. When the bit is high the USIM SPI/I²C interface is enabled. If the USIM is configured to operate as an SPI interface via the UMD and SIM2~SIM0 bits, the contents of the SPI control registers will remain at the previous settings when the SIMEN bit changes from low to high and should therefore be first initialised by the application program. If the USIM is configured to operate as an I²C interface via the UMD and SIM2~SIM0 bits and the SIMEN bit changes from low to high, the contents of the I²C control bits such as HTX and TXAK will remain at the previous settings and should therefore be first initialised by the application

program while the relevant I²C flags such as HCF, HAAS, HBB, SRW and RXAK will be set to their default states.

Bit 0 **SIMICF**: USIM SPI Incomplete Flag
This bit is only available when the USIM is configured to operate in an SPI slave mode. Refer to the SPI register section.

• **SIMC1 Register**

Bit	7	6	5	4	3	2	1	0
Name	HCF	HAAS	HBB	HTX	TXAK	SRW	IAMWU	RXAK
R/W	R	R	R	R/W	R/W	R	R/W	R
POR	1	0	0	0	0	0	0	1

Bit 7 **HCF**: I²C Bus data transfer completion flag
0: Data is being transferred
1: Completion of an 8-bit data transfer
The HCF flag is the data transfer flag. This flag will be zero when data is being transferred. Upon completion of an 8-bit data transfer the flag will go high and an interrupt will be generated.

Bit 6 **HAAS**: I²C Bus address match flag
0: Not address match
1: Address match
The HAAS flag is the address match flag. This flag is used to determine if the slave device address is the same as the master transmit address. If the addresses match then this bit will be high, if there is no match then the flag will be low.

Bit 5 **HBB**: I²C Bus busy flag
0: I²C Bus is not busy
1: I²C Bus is busy
The HBB flag is the I²C busy flag. This flag will be “1” when the I²C bus is busy which will occur when a START signal is detected. The flag will be set to “0” when the bus is free which will occur when a STOP signal is detected.

Bit 4 **HTX**: I²C slave device is transmitter or receiver selection
0: Slave device is the receiver
1: Slave device is the transmitter

Bit 3 **TXAK**: I²C Bus transmit acknowledge flag
0: Slave send acknowledge flag
1: Slave do not send acknowledge flag
The TXAK bit is the transmit acknowledge flag. After the slave device receipt of 8 bits of data, this bit will be transmitted to the bus on the 9th clock from the slave device. The slave device must always set TXAK bit to “0” before further data is received.

Bit 2 **SRW**: I²C Slave Read/Write flag
0: Slave device should be in receive mode
1: Slave device should be in transmit mode
The SRW flag is the I²C Slave Read/Write flag. This flag determines whether the master device wishes to transmit or receive data from the I²C bus. When the transmitted address and slave address is match, that is when the HAAS flag is set high, the slave device will check the SRW flag to determine whether it should be in transmit mode or receive mode. If the SRW flag is high, the master is requesting to read data from the bus, so the slave device should be in transmit mode. When the SRW flag is zero, the master will write data to the bus, therefore the slave device should be in receive mode to read this data.

Bit 1	IAMWU: I ² C Address Match Wake-up control 0: Disable 1: Enable This bit should be set high to enable the I ² C address match wake up from the SLEEP or IDLE Mode. If the IAMWU bit has been set before entering either the SLEEP or IDLE mode to enable the I ² C address match wake up, then this bit must be cleared to zero by the application program after wake-up to ensure correction device operation.
Bit 0	RXAK: I ² C Bus Receive acknowledge flag 0: Slave receive acknowledge flag 1: Slave does not receive acknowledge flag The RXAK flag is the receiver acknowledge flag. When the RXAK flag is “0”, it means that a acknowledge signal has been received at the 9th clock, after 8 bits of data have been transmitted. When the slave device in the transmit mode, the slave device checks the RXAK flag to determine if the master receiver wishes to receive the next byte. The slave transmitter will therefore continue sending out data until the RXAK flag is “1”. When this occurs, the slave transmitter will release the SDA line to allow the master to send a STOP signal to release the I ² C Bus.

I²C Bus Communication

Communication on the I²C bus requires four separate steps, a START signal, a slave device address transmission, a data transmission and finally a STOP signal. When a START signal is placed on the I²C bus, all devices on the bus will receive this signal and be notified of the imminent arrival of data on the bus. The first seven bits of the data will be the slave address with the first bit being the MSB. If the address of the slave device matches that of the transmitted address, the HAAS bit in the SIMC1 register will be set and an USIM interrupt will be generated. After entering the interrupt service routine, the slave device must first check the condition of the HAAS and SIMTOF bits to determine whether the interrupt source originates from an address match or from the completion of an 8-bit data transfer completion or from the I²C bus time-out occurrence. During a data transfer, note that after the 7-bit slave address has been transmitted, the following bit, which is the 8th bit, is the read/write bit whose value will be placed in the SRW bit. This bit will be checked by the slave device to determine whether to go into transmit or receive mode. Before any transfer of data to or from the I²C bus, the microcontroller must initialise the bus, the following are steps to achieve this:

- Step 1
Set the UMD, SIM2~SIM0 and SIMEN bits in the SIMC0 register to “0”, “110” and “1” respectively to enable the I²C bus.
- Step 2
Write the slave address of the device to the I²C bus address register SIMA.
- Step 3
Set the USIME interrupt enable bit of the interrupt control register to enable the USIM interrupt.

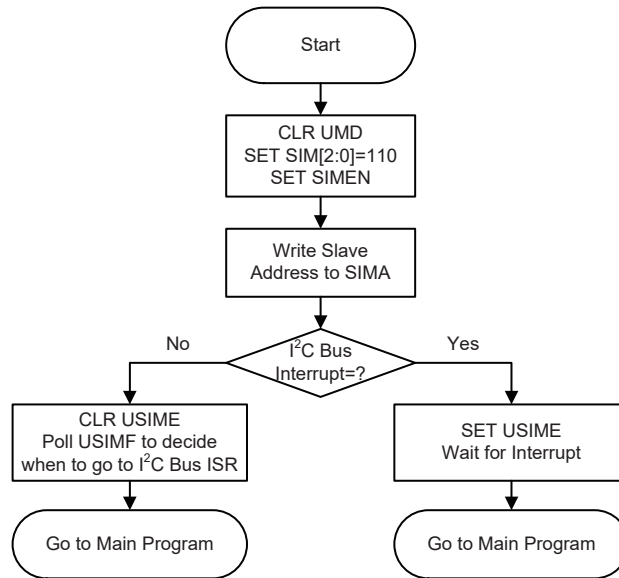

I²C Bus Initialisation Flow Chart

I²C Bus Start Signal

The START signal can only be generated by the master device connected to the I²C bus and not by the slave device. This START signal will be detected by all devices connected to the I²C bus. When detected, this indicates that the I²C bus is busy and therefore the HBB bit will be set. A START condition occurs when a high to low transition on the SDA line takes place when the SCL line remains high.

I²C Slave Address

The transmission of a START signal by the master will be detected by all devices on the I²C bus. To determine which slave device the master wishes to communicate with, the address of the slave device will be sent out immediately following the START signal. All slave devices, after receiving this 7-bit address data, will compare it with their own 7-bit slave address. If the address sent out by the master matches the internal address of the microcontroller slave device, then an internal USIM I²C bus interrupt signal will be generated. The next bit following the address, which is the 8th bit, defines the read/write status and will be saved to the SRW bit of the SIMC1 register. The slave device will then transmit an acknowledge bit, which is a low level, as the 9th bit. The slave device will also set the status flag HAAS when the addresses match.

As a USIM I²C bus interrupt signal can come from three sources, when the program enters the interrupt subroutine, the HAAS and SIMTOF bits should be examined to see whether the interrupt source has come from a matching slave address or from the completion of a data byte transfer or from the I²C bus time-out occurrence. When a slave address is matched, the device must be placed in either the transmit mode and then write data to the SIMD register, or in the receive mode where it must implement a dummy read from the SIMD register to release the SCL line.

I²C Bus Read/Write Signal

The SRW bit in the SIMC1 register defines whether the master device wishes to read data from the I²C bus or write data to the I²C bus. The slave device should examine this bit to determine if it is to be a transmitter or a receiver. If the SRW flag is “1” then this indicates that the master device wishes to read data from the I²C bus, therefore the slave device must be setup to send data to the I²C bus as a transmitter. If the SRW flag is “0” then this indicates that the master wishes to send data to the I²C bus, therefore the slave device must be setup to read data from the I²C bus as a receiver.

I²C Bus Slave Address Acknowledge Signal

After the master has transmitted a calling address, any slave device on the I²C bus, whose own internal address matches the calling address, must generate an acknowledge signal. The acknowledge signal will inform the master that a slave device has accepted its calling address. If no acknowledge signal is received by the master then a STOP signal must be transmitted by the master to end the communication. When the HAAS flag is high, the addresses have matched and the slave device must check the SRW flag to determine if it is to be a transmitter or a receiver. If the SRW flag is high, the slave device should be setup to be a transmitter so the HTX bit in the SIMC1 register should be set to “1”. If the SRW flag is low, then the microcontroller slave device should be setup as a receiver and the HTX bit in the SIMC1 register should be set to “0”.

I²C Bus Data and Acknowledge Signal

The transmitted data is 8-bit wide and is transmitted after the slave device has acknowledged receipt of its slave address. The order of serial bit transmission is the MSB first and the LSB last. After receipt of 8 bits of data, the receiver must transmit an acknowledge signal, level “0”, before it can receive the next data byte. If the slave transmitter does not receive an acknowledge bit signal from the master receiver, then the slave transmitter will release the SDA line to allow the master to send a STOP signal to release the I²C Bus. The corresponding data will be stored in the SIMD register. If setup as a transmitter, the slave device must first write the data to be transmitted into the SIMD register. If setup as a receiver, the slave device must read the transmitted data from the SIMD register.

When the slave receiver receives the data byte, it must generate an acknowledge bit, known as TXAK, on the 9th clock. The slave device, which is setup as a transmitter will check the RXAK bit in the SIMC1 register to determine if it is to send another data byte, if not then it will release the SDA line and await the receipt of a STOP signal from the master.

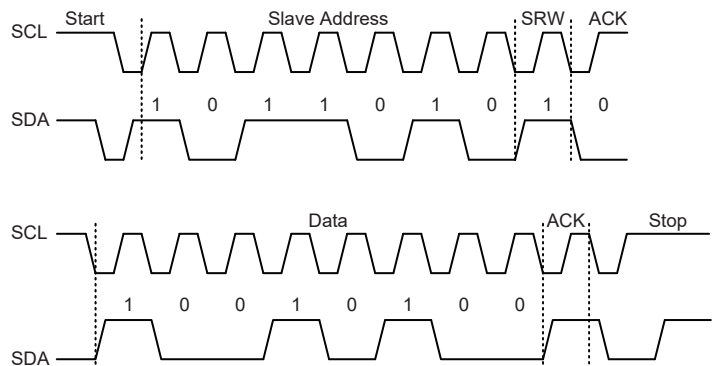

S=Start (1 bit)
 SA=Slave Address (7 bits)
 SR=SRW bit (1 bit)
 M=Slave device send acknowledge bit (1 bit)
 D=Data (8 bits)
 A=ACK (RXAK bit for transmitter, TXAK bit for receiver, 1 bit)
 P=Stop (1 bit)

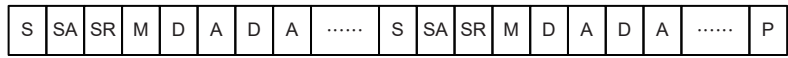

I²C Communication Timing Diagram

Note: When a slave address is matched, the device must be placed in either the transmit mode and then write data to the SIMD register, or in the receive mode where it must implement a dummy read from the SIMD register to release the SCL line.

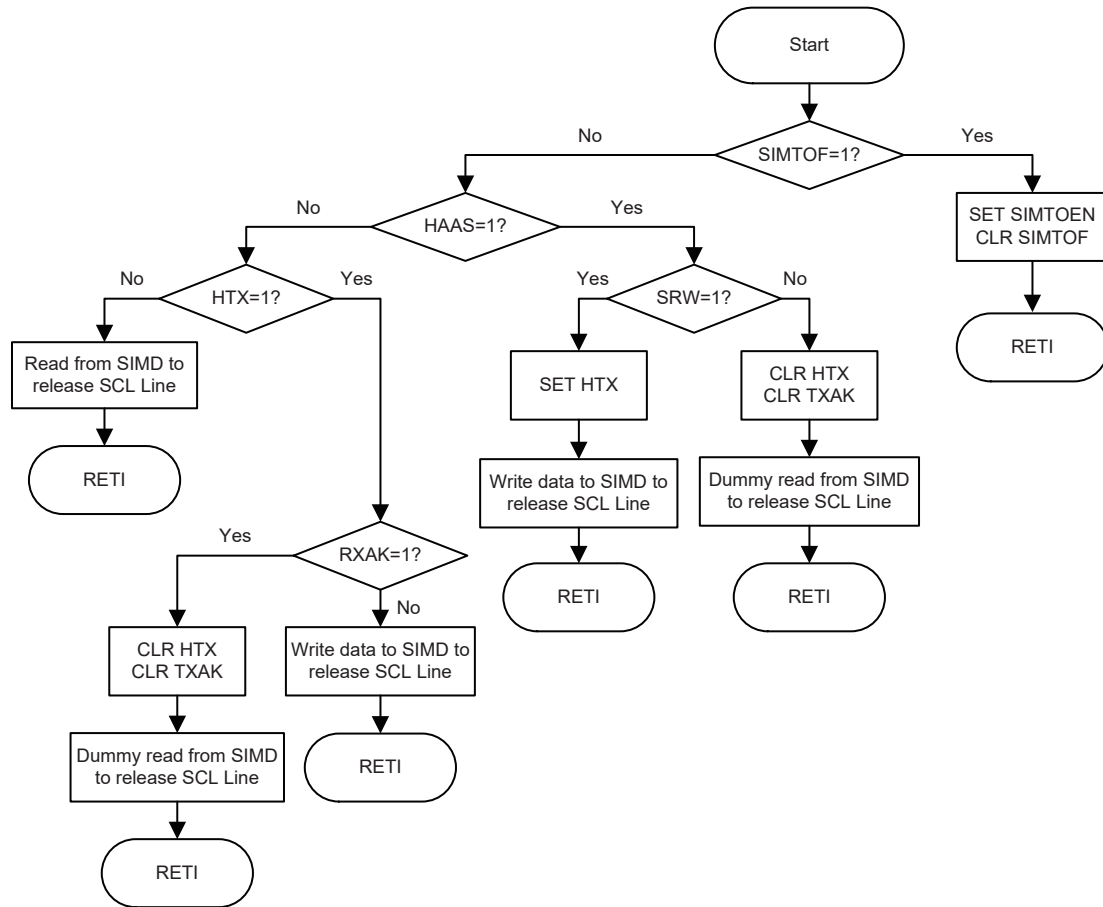

I²C Bus ISR Flow Chart

I²C Time-out Control

In order to reduce the problem of I²C lockup due to reception of erroneous clock sources, a time-out function is provided. If the clock source to the I²C is not received for a while, then the I²C circuitry and registers will be reset after a certain time-out period. The time-out counter starts counting on an I²C bus “START” & “address match” condition, and is cleared by an SCL falling edge. Before the next SCL falling edge arrives, if the time elapsed is greater than the time-out setup by the SIMTOC register, then a time-out condition will occur. The time-out function will stop when an I²C “STOP” condition occurs.

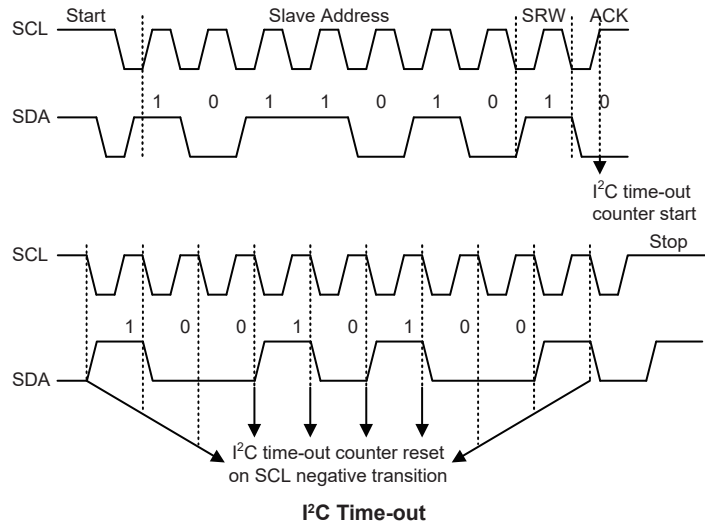

When an I²C time-out counter overflow occurs, the counter will stop and the SIMTOEN bit will be cleared to zero and the SIMTOF bit will be set high to indicate that a time-out condition has occurred. The time-out condition will also generate an interrupt which uses the USIM interrupt vector. When an I²C time-out occurs, the I²C internal circuitry will be reset and the registers will be reset into the following condition:

Registers	After I ² C Time-out
SIMD, SIMA, SIMC0	No change
SIMC1	Reset to POR condition

I²C Registers after Time-out

The SIMTOF flag can be cleared by the application program. There are 64 time-out periods which can be selected using SIMTOS bit field in the SIMTOC register. The time-out time is given by the formula: $((1\sim64)\times32)/f_{SUB}$. This gives a time-out period which ranges from about 1ms to 64ms.

• **SIMTOC Register**

Bit	7	6	5	4	3	2	1	0
Name	SIMTOEN	SIMTOF	SIMTOS5	SIMTOS4	SIMTOS3	SIMTOS2	SIMTOS1	SIMTOS0
R/W	R/W	R/W	R/W	R/W	R/W	R/W	R/W	R/W
POR	0	0	0	0	0	0	0	0

Bit 7 **SIMTOEN**: USIM I²C Time-out control
 0: Disable
 1: Enable

Bit 6 **SIMTOF**: USIM I²C Time-out flag
 0: No time-out occurred
 1: Time-out occurred

This bit is set high when time-out occurs and can only be cleared to zero by application program.

Bit 5~0 **SIMTOS5~SIMTOS0**: USIM I²C Time-out period selection
 I²C time-out clock source is $f_{SUB}/32$.
 I²C time-out time is equal to $(SIMTOS[5:0]+1)\times(32/f_{SUB})$.

UART Interface

The device contains an integrated full-duplex asynchronous serial communications UART interface that enables communication with external devices that contain a serial interface. The UART function has many features and can transmit and receive data serially by transferring a frame of data with eight or nine data bits per transmission as well as being able to detect errors when the data is overwritten or incorrectly framed. The UART function shares the same internal interrupt vector with the SPI and I²C interfaces which can be used to indicate when a reception occurs or when a transmission terminates.

The integrated UART function contains the following features:

- Full-duplex, asynchronous communication
- 8 or 9 bits character length
- Even, odd or no parity options
- One or two stop bits
- Baud rate generator with 8-bit prescaler
- Parity, framing, noise and overrun error detection
- Support for interrupt on address detect (last character bit=1)
- Separately enabled transmitter and receiver
- 2-byte Deep FIFO Receive Data Buffer
- RX pin wake-up function
- Transmit and receive interrupts
- Interrupts can be initialized by the following conditions:
 - ♦ Transmitter Empty
 - ♦ Transmitter Idle
 - ♦ Receiver Full
 - ♦ Receiver Overrun
 - ♦ Address Mode Detect

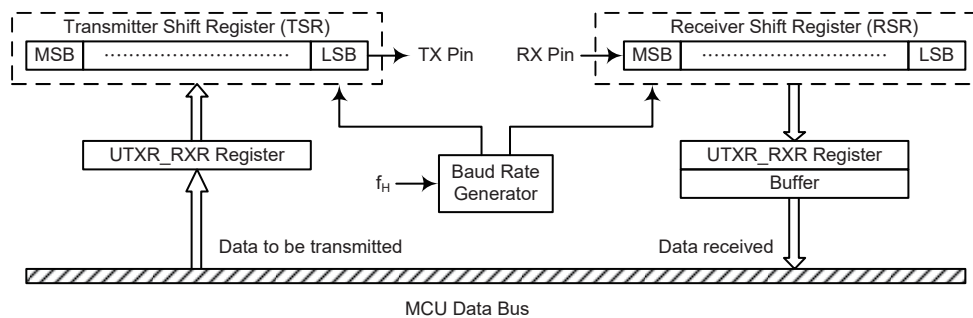

UART Data Transfer Block Diagram

UART External Pins

To communicate with an external serial interface, the internal UART has two external pins known as TX and RX. The TX and RX pins are the UART transmitter and receiver pins respectively. The TX and RX pin function should first be selected by the corresponding pin-shared function selection register before the UART function is used. Along with the UMD bit, the UREN bit, the UTXEN and URXEN bits, if set, will setup these pins to their respective TX output and RX input conditions and disable any pull-high resistor option which may exist on the TX and RX pins. When the TX or RX

pin function is disabled by clearing the UMD, UREN, UTXEN or URXEN bit, the TX or RX pin will be set to a floating state. At this time whether the internal pull-high resistor is connected to the TX or RX pin or not is determined by the corresponding I/O pull-high function control bit.

UART Data Transfer Scheme

The above block diagram shows the overall data transfer structure arrangement for the UART. The actual data to be transmitted from the MCU is first transferred to the UTXR_RXR register by the application program. The data will then be transferred to the Transmit Shift Register from where it will be shifted out, LSB first, onto the TX pin at a rate controlled by the Baud Rate Generator. Only the UTXR_RXR register is mapped onto the MCU Data Memory, the Transmit Shift Register is not mapped and is therefore inaccessible to the application program.

Data to be received by the UART is accepted on the external RX pin, from where it is shifted in, LSB first, to the Receiver Shift Register at a rate controlled by the Baud Rate Generator. When the shift register is full, the data will then be transferred from the shift register to the internal UTXR_RXR register, where it is buffered and can be manipulated by the application program. Only the UTXR_RXR register is mapped onto the MCU Data Memory, the Receiver Shift Register is not mapped and is therefore inaccessible to the application program.

It should be noted that the actual register for data transmission and reception only exists as a single shared register in the Data Memory. This shared register known as the UTXR_RXR register is used for both data transmission and data reception.

UART Status and Control Registers

There are six control registers associated with the UART function. The UMD bit in the SIMC0 register can be used to select the UART mode. The UUSR, UUCR1 and UUCR2 registers control the overall function of the UART, while the UBRG register controls the Baud rate. The actual data to be transmitted and received on the serial interface is managed through the UTXR_RXR data register. Note that UART related registers and their POR values are only available when the UART mode is selected by setting the UMD bit in the SIMC0 register to “1”.

Register Name	Bit							
	7	6	5	4	3	2	1	0
SIMC0	SIM2	SIM1	SIM0	UMD	SIMDEB1	SIMDEB0	SIMEN	SIMICF
UUSR	UPERR	UNF	UFERR	UOERR	URIDLE	URXIF	UTIDLE	UTXIF
UUCR1	UREN	UBNO	UPREN	UPRT	USTOPS	UTXBRK	URX8	UTX8
UUCR2	UTXEN	URXEN	UBRGH	UADDEN	UWAKE	URIE	UTIIE	UTEIE
UTXR_RXR	UTXRX7	UTXRX6	UTXRX5	UTXRX4	UTXRX3	UTXRX2	UTXRX1	UTXRX0
UBRG	UBRG7	UBRG6	UBRG5	UBRG4	UBRG3	UBRG2	UBRG1	UBRG0

UART Register List

• SIMC0 Register

Bit	7	6	5	4	3	2	1	0
Name	SIM2	SIM1	SIM0	UMD	SIMDEB1	SIMDEB0	SIMEN	SIMICF
R/W	R/W	R/W	R/W	R/W	R/W	R/W	R/W	R/W
POR	1	1	1	0	0	0	0	0

Bit 7~5 **SIM2~SIM0**: USIM SPI/I²C Operating Mode Control
 When the UMD bit is cleared to zero, these bits setup the SPI or I²C operating mode of the USIM function. Refer to the SPI or I²C register section for more details.

- Bit 4 **UMD**: UART mode selection bit
 0: SPI or I²C mode
 1: UART mode
 This bit is used to select the UART mode. When this bit is cleared to zero, the actual SPI or I²C mode can be selected using the SIM2~SIM0 bits. Note that the UMD bit must be set low for SPI or I²C mode.
- Bit 3~2 **SIMDEB1~SIMDEB0**: I²C Debounce Time Selection
 Refer to the I²C register section.
- Bit 1 **SIMEN**: USIM SPI/I²C Enable Control
 This bit is only available when the USIM is configured to operate in an SPI or I²C mode with the UMD bit set low. Refer to the SPI or I²C register section for more details.
- Bit 0 **SIMICF**: USIM SPI Incomplete Flag
 Refer to the SPI register section.

• **UUSR Register**

The UUSR register is the status register for the UART, which can be read by the program to determine the present status of the UART. All flags within the UUSR register are read only. Further explanation on each of the flags is given below:

Bit	7	6	5	4	3	2	1	0
Name	UPERR	UNF	UFERR	UOERR	URIDLE	URXIF	UTIDLE	UTXIF
R/W	R	R	R	R	R	R	R	R
POR	0	0	0	0	1	0	1	1

- Bit 7 **UPERR**: Parity error flag
 0: No parity error is detected
 1: Parity error is detected
 The UPERR flag is the parity error flag. When this read only flag is “0”, it indicates a parity error has not been detected. When the flag is “1”, it indicates that the parity of the received word is incorrect. This error flag is applicable only if Parity mode (odd or even) is selected. The flag can also be cleared to zero by a software sequence which involves a read to the status register UUSR followed by an access to the UTXR_RXR data register.
- Bit 6 **UNF**: Noise flag
 0: No noise is detected
 1: Noise is detected
 The UNF flag is the noise flag. When this read only flag is “0”, it indicates no noise condition. When the flag is “1”, it indicates that the UART has detected noise on the receiver input. The UNF flag is set during the same cycle as the URXIF flag but will not be set in the case of an overrun. The UNF flag can be cleared to zero by a software sequence which will involve a read to the status register UUSR followed by an access to the UTXR_RXR data register.
- Bit 5 **UFERR**: Framing error flag
 0: No framing error is detected
 1: Framing error is detected
 The UFERR flag is the framing error flag. When this read only flag is “0”, it indicates that there is no framing error. When the flag is “1”, it indicates that a framing error has been detected for the current character. The flag can also be cleared to zero by a software sequence which will involve a read to the status register UUSR followed by an access to the UTXR_RXR data register.

- Bit 4 **UOERR:** Overrun error flag
 0: No overrun error is detected
 1: Overrun error is detected
- The UOERR flag is the overrun error flag which indicates when the receiver buffer has overflowed. When this read only flag is “0”, it indicates that there is no overrun error. When the flag is “1”, it indicates that an overrun error occurs which will inhibit further transfers to the UTXR_RXR receive data register. The flag is cleared to zero by a software sequence, which is a read to the status register UUSR followed by an access to the UTXR_RXR data register.
- Bit 3 **URIDLE:** Receiver status
 0: Data reception is in progress (Data being received)
 1: No data reception is in progress (Receiver is idle)
- The URIDLE flag is the receiver status flag. When this read only flag is “0”, it indicates that the receiver is between the initial detection of the start bit and the completion of the stop bit. When the flag is “1”, it indicates that the receiver is idle. Between the completion of the stop bit and the detection of the next start bit, the URIDLE bit is “1” indicating that the UART receiver is idle and the RX pin stays in logic high condition.
- Bit 2 **URXIF:** Receive UTXR_RXR data register status
 0: UTXR_RXR data register is empty
 1: UTXR_RXR data register has available data
- The URXIF flag is the receive data register status flag. When this read only flag is “0”, it indicates that the UTXR_RXR read data register is empty. When the flag is “1”, it indicates that the UTXR_RXR read data register contains new data. When the contents of the shift register are transferred to the UTXR_RXR register, an interrupt is generated if URIE=1 in the UUCR2 register. If one or more errors are detected in the received word, the appropriate receive-related flags UNF, UFERR, and/or UPERR are set within the same clock cycle. The URXIF flag will eventually be cleared to zero when the UUSR register is read with URXIF set, followed by a read from the UTXR_RXR register, and if the UTXR_RXR register has no more new data available.
- Bit 1 **UTIDLE:** Transmission idle
 0: Data transmission is in progress (Data being transmitted)
 1: No data transmission is in progress (Transmitter is idle)
- The UTIDLE flag is known as the transmission complete flag. When this read only flag is “0”, it indicates that a transmission is in progress. This flag will be set high when the UTXIF flag is “1” and when there is no transmit data or break character being transmitted. When UTIDLE is equal to “1”, the TX pin becomes idle with the pin state in logic high condition. The UTIDLE flag is cleared to zero by reading the UUSR register with UTIDLE set and then writing to the UTXR_RXR register. The flag is not generated when a data character or a break is queued and ready to be sent.
- Bit 0 **UTXIF:** Transmit UTXR_RXR data register status
 0: Character is not transferred to the transmit shift register
 1: Character has transferred to the transmit shift register (UTXR_RXR data register is empty)
- The UTXIF flag is the transmit data register empty flag. When this read only flag is “0”, it indicates that the character is not transferred to the transmitter shift register. When the flag is “1”, it indicates that the transmitter shift register has received a character from the UTXR_RXR data register. The UTXIF flag is cleared to zero by reading the UART status register (UUSR) with UTXIF set and then writing to the UTXR_RXR data register. Note that when the UTXEN bit is set, the UTXIF flag bit will also be set since the transmit data register is not yet full.

• **UUCR1 Register**

The UUCR1 register together with the UUCR2 register are the two UART control registers that are used to set the various options for the UART function, such as overall on/off control, parity control, data transfer bit length etc. Further explanation on each of the bits is given below:

Bit	7	6	5	4	3	2	1	0
Name	UREN	UBNO	UPREN	UPRT	USTOPS	UTXBRK	URX8	UTX8
R/W	R/W	R/W	R/W	R/W	R/W	R/W	R	W
POR	0	0	0	0	0	0	x	0

“x”: unknown

Bit 7 **UREN**: UART function enable control

- 0: Disable UART. TX and RX pins are in a floating state
- 1: Enable UART. TX and RX pins function as UART pins

The UREN bit is the UART enable bit. When this bit is equal to “0”, the UART will be disabled and the RX pin as well as the TX pin will be set in a floating state. When the bit is equal to “1”, the UART will be enabled if the UMD bit is set and the TX and RX pins will function as defined by the UTXEN and URXEN enable control bits.

When the UART is disabled, it will empty the buffer so any character remaining in the buffer will be discarded. In addition, the value of the baud rate counter will be reset. If the UART is disabled, all error and status flags will be reset. Also the UTXEN, URXEN, UTXBRK, URXIF, UOERR, UFERR, UPERR and UNF bits will be cleared to zero, while the UTIDLE, UTXIF and URIDLE bits will be set high. Other control bits in UUCR1, UUCR2 and UBRG registers will remain unaffected. If the UART is active and the UREN bit is cleared to zero, all pending transmissions and receptions will be terminated and the module will be reset as defined above. When the UART is re-enabled, it will restart in the same configuration.

Bit 6 **UBNO**: Number of data transfer bits selection

- 0: 8-bit data transfer
- 1: 9-bit data transfer

This bit is used to select the data length format, which can have a choice of either 8-bit or 9-bit format. When this bit is equal to “1”, a 9-bit data length format will be selected. If the bit is equal to “0”, then an 8-bit data length format will be selected. If 9-bit data length format is selected, then bits URX8 and UTX8 will be used to store the 9th bit of the received and transmitted data respectively.

Bit 5 **UPREN**: Parity function enable control

- 0: Parity function is disabled
- 1: Parity function is enabled

This is the parity enable bit. When this bit is equal to “1”, the parity function will be enabled. If the bit is equal to “0”, then the parity function will be disabled.

Bit 4 **UPRT**: Parity type selection bit

- 0: Even parity for parity generator
- 1: Odd parity for parity generator

This bit is the parity type selection bit. When this bit is equal to “1”, odd parity type will be selected. If the bit is equal to “0”, then even parity type will be selected.

Bit 3 **USTOPS**: Number of Stop bits selection

- 0: One stop bit format is used
- 1: Two stop bits format is used

This bit determines if one or two stop bits are to be used. When this bit is equal to “1”, two stop bits are used. If this bit is equal to “0”, then only one stop bit is used.

Bit 2 **UTXBRK**: Transmit break character

- 0: No break character is transmitted
- 1: Break characters transmit

The UTXBRK bit is the Transmit Break Character bit. When this bit is “0”, there are no break characters and the TX pin operates normally. When the bit is “1”, there are

transmit break characters and the transmitter will send logic zeros. When this bit is equal to “1”, after the buffered data has been transmitted, the transmitter output is held low for a minimum of a 13-bit length and until the UTXBRK bit is reset.

- Bit 1 **URX8**: Receive data bit 8 for 9-bit data transfer format (read only)
 This bit is only used if 9-bit data transfers are used, in which case this bit location will store the 9th bit of the received data known as URX8. The UBNO bit is used to determine whether data transfers are in 8-bit or 9-bit format.
- Bit 0 **UTX8**: Transmit data bit 8 for 9-bit data transfer format (write only)
 This bit is only used if 9-bit data transfers are used, in which case this bit location will store the 9th bit of the transmitted data known as UTX8. The UBNO bit is used to determine whether data transfers are in 8-bit or 9-bit format.

• **UUCR2 Register**

The UUCR2 register is the second of the two UART control registers and serves several purposes. One of its main functions is to control the basic enable/disable operation of the UART Transmitter and Receiver as well as enabling the various USIM UART mode interrupt sources. The register also serves to control the baud rate speed, receiver wake-up enable and the address detect enable. Further explanation on each of the bits is given below:

Bit	7	6	5	4	3	2	1	0
Name	UTXEN	URXEN	UBRGH	UADDEN	UWAKE	URIE	UTIIE	UTEIE
R/W	R/W	R/W	R/W	R/W	R/W	R/W	R/W	R/W
POR	0	0	0	0	0	0	0	0

- Bit 7 **UTXEN**: UART Transmitter enabled control
 0: UART transmitter is disabled
 1: UART transmitter is enabled
 The bit named UTXEN is the Transmitter Enable Bit. When this bit is equal to “0”, the transmitter will be disabled with any pending data transmissions being aborted. In addition the buffers will be reset. In this situation the TX pin will be set in a floating state.
 If the UTXEN bit is equal to “1” and the UMD and UREN bit are also equal to “1”, the transmitter will be enabled and the TX pin will be controlled by the UART. Clearing the UTXEN bit during a transmission will cause the data transmission to be aborted and will reset the transmitter. If this situation occurs, the TX pin will be set in a floating state.
- Bit 6 **URXEN**: UART Receiver enabled control
 0: UART receiver is disabled
 1: UART receiver is enabled
 The bit named URXEN is the Receiver Enable Bit. When this bit is equal to “0”, the receiver will be disabled with any pending data receptions being aborted. In addition the receive buffers will be reset. In this situation the RX pin will be set in a floating state. If the URXEN bit is equal to “1” and the UMD and UREN bit are also equal to “1”, the receiver will be enabled and the RX pin will be controlled by the UART. Clearing the URXEN bit during a reception will cause the data reception to be aborted and will reset the receiver. If this situation occurs, the RX pin will be set in a floating state.
- Bit 5 **UBRGH**: Baud Rate speed selection
 0: Low speed baud rate
 1: High speed baud rate
 The bit named UBRGH selects the high or low speed mode of the Baud Rate Generator. This bit, together with the value placed in the baud rate register UBRG, controls the Baud Rate of the UART. If this bit is equal to “1”, the high speed mode is selected. If the bit is equal to “0”, the low speed mode is selected.

- Bit 4 **UADDEN:** Address detect function enable control
 0: Address detect function is disabled
 1: Address detect function is enabled
 The bit named UADDEN is the address detect function enable control bit. When this bit is equal to “1”, the address detect function is enabled. When it occurs, if the 8th bit, which corresponds to URX7 if UBNO=0 or the 9th bit, which corresponds to URX8 if UBNO=1, has a value of “1”, then the received word will be identified as an address, rather than data. If the corresponding interrupt is enabled, an interrupt request will be generated each time the received word has the address bit set, which is the 8th or 9th bit depending on the value of UBNO. If the address bit known as the 8th or 9th bit of the received word is “0” with the address detect function being enabled, an interrupt will not be generated and the received data will be discarded.
- Bit 3 **UWAKE:** RX pin wake-up UART function enable control
 0: RX pin wake-up UART function is disabled
 1: RX pin wake-up UART function is enabled
 This bit is used to control the wake-up UART function when a falling edge on the RX pin occurs. Note that this bit is only available when the UART clock (f_{H}) is switched off. There will be no RX pin wake-up UART function if the UART clock (f_{H}) exists. If the UWAKE bit is set high as the UART clock (f_{H}) is switched off, a UART wake-up request will be initiated when a falling edge on the RX pin occurs. When this request happens and the corresponding interrupt is enabled, an RX pin wake-up UART interrupt will be generated to inform the MCU to wake up the UART function by switching on the UART clock (f_{H}) via the application program. Otherwise, the UART function cannot resume even if there is a falling edge on the RX pin when the UWAKE bit is cleared to zero.
- Bit 2 **URIE:** Receiver interrupt enable control
 0: Receiver related interrupt is disabled
 1: Receiver related interrupt is enabled
 This bit enables or disables the receiver interrupt. If this bit is equal to “1” and when the receiver overrun flag UOERR or receive data available flag URXIF is set, the USIM interrupt request flag USIMF will be set. If this bit is equal to “0”, the USIM interrupt request flag USIMF will not be influenced by the condition of the UOERR or URXIF flags.
- Bit 1 **UTIE:** Transmitter Idle interrupt enable control
 0: Transmitter idle interrupt is disabled
 1: Transmitter idle interrupt is enabled
 This bit enables or disables the transmitter idle interrupt. If this bit is equal to “1” and when the transmitter idle flag UTIDLE is set, due to a transmitter idle condition, the USIM interrupt request flag USIMF will be set. If this bit is equal to “0”, the USIM interrupt request flag USIMF will not be influenced by the condition of the UTIDLE flag.
- Bit 0 **UTEIE:** Transmitter Empty interrupt enable control
 0: Transmitter empty interrupt is disabled
 1: Transmitter empty interrupt is enabled
 This bit enables or disables the transmitter empty interrupt. If this bit is equal to “1” and when the transmitter empty flag UTXIF is set, due to a transmitter empty condition, the USIM interrupt request flag USIMF will be set. If this bit is equal to “0”, the USIM interrupt request flag USIMF will not be influenced by the condition of the UTXIF flag.

• **UTXR_RXR Register**

The UTXR_RXR register is the data register which is used to store the data to be transmitted on the TX pin or being received from the RX pin.

Bit	7	6	5	4	3	2	1	0
Name	UTXRX7	UTXRX6	UTXRX5	UTXRX4	UTXRX3	UTXRX2	UTXRX1	UTXRX0
R/W	R/W	R/W	R/W	R/W	R/W	R/W	R/W	R/W
POR	x	x	x	x	x	x	x	x

"x": unknown

Bit 7~0 **UTXRX7~UTXRX0**: UART Transmit/Receive Data bit 7~bit 0

• **UBRG Register**

Bit	7	6	5	4	3	2	1	0
Name	UBRG7	UBRG6	UBRG5	UBRG4	UBRG3	UBRG2	UBRG1	UBRG0
R/W	R/W	R/W	R/W	R/W	R/W	R/W	R/W	R/W
POR	x	x	x	x	x	x	x	x

"x": unknown

Bit 7~0 **UBRG7~UBRG0**: Baud Rate values

By programming the UBRGH bit in UUCR2 register which allows selection of the related formula described above and programming the required value in the UBRG register, the required baud rate can be setup.

Note: Baud rate= $f_{H}/[64 \times (N+1)]$ if UBRGH=0.

Baud rate= $f_{H}/[16 \times (N+1)]$ if UBRGH=1.

Baud Rate Generator

To setup the speed of the serial data communication, the UART function contains its own dedicated baud rate generator. The baud rate is controlled by its own internal free running 8-bit timer, the period of which is determined by two factors. The first of these is the value placed in the baud rate register UBRG and the second is the value of the UBRGH bit in the control register UUCR2. The UBRGH bit decides if the baud rate generator is to be used in a high speed mode or low speed mode, which in turn determines the formula that is used to calculate the baud rate. The value N in the UBRG register which is used in the following baud rate calculation formula determines the division factor. Note that N is the decimal value placed in the UBRG register and has a range of between 0 and 255.

UUCR2 UBRGH Bit	0	1
Baud Rate (BR)	$f_{H}/[64 (N+1)]$	$f_{H}/[16 (N+1)]$

By programming the UBRGH bit which allows selection of the related formula and programming the required value in the UBRG register, the required baud rate can be setup. Note that because the actual baud rate is determined using a discrete value, N, placed in the UBRG register, there will be an error associated between the actual and requested value. The following example shows how the UBRG register value N and the error value can be calculated.

Calculating the Baud Rate and Error Values

For a clock frequency of 4MHz, and with UBRGH cleared to zero determine the UBRG register value N, the actual baud rate and the error value for a desired baud rate of 4800.

From the above table the desired baud rate $BR=f_{H}/[64 (N+1)]$

Re-arranging this equation gives $N=[f_{H}/(BR \times 64)] - 1$

Giving a value for $N=[4000000/(4800 \times 64)] - 1=12.0208$

To obtain the closest value, a decimal value of 12 should be placed into the UBRG register. This gives an actual or calculated baud rate value of $BR=4000000/[64 \times (12+1)]=4808$

Therefore the error is equal to $(4808 - 4800)/4800=0.16\%$

UART Setup and Control

For data transfer, the UART function utilizes a non-return-to-zero, more commonly known as NRZ, format. This is composed of one start bit, eight or nine data bits, and one or two stop bits. Parity is supported by the UART hardware, and can be setup to be even, odd or no parity. For the most common data format, 8 data bits along with no parity and one stop bit, denoted as 8, N, 1, is used as the default setting, which is the setting at power-on. The number of data bits and stop bits, along with the parity, are setup by programming the corresponding UBNO, UPRT, UPREN, and USTOPS bits in the UUCR1 register. The baud rate used to transmit and receive data is setup using the internal 8-bit baud rate generator, while the data is transmitted and received LSB first. Although the UART transmitter and receiver are functionally independent, they both use the same data format and baud rate. In all cases stop bits will be used for data transmission.

Enabling/Disabling the UART Interface

The basic on/off function of the internal UART function is controlled using the UREN bit in the UUCR1 register. When the UART mode is selected by setting the UMD bit in the SIMC0 register to “1”, if the UREN, UTXEN and URXEN bits are set, then these two UART pins will act as normal TX output pin and RX input pin respectively. If no data is being transmitted on the TX pin, then it will default to a logic high value.

Clearing the UREN bit will disable the TX and RX pins and allow these two pins to be used as normal I/O or other pin-shared functional pins by configuring the corresponding pin-shared control bits. When the UART function is disabled the buffer will be reset to an empty condition, at the same time discarding any remaining residual data. Disabling the UART will also reset the error and status flags with bits UTXEN, URXEN, UTXBRK, URXIF, UOERR, UFERR, UPERR and UNF being cleared while bits UTIDLE, UTXIF and URIDLE will be set. The remaining control bits in the UUCR1, UUCR2 and UBRG registers will remain unaffected. If the UREN bit in the UUCR1 register is cleared while the UART is active, then all pending transmissions and receptions will be immediately suspended and the UART will be reset to a condition as defined above. If the UART is then subsequently re-enabled, it will restart again in the same configuration.

Data, Parity and Stop Bit Selection

The format of the data to be transferred is composed of various factors such as data bit length, parity on/off, parity type, address bits and the number of stop bits. These factors are determined by the setup of various bits within the UUCR1 register. The UBNO bit controls the number of data bits which can be set to either 8 or 9, the UPRT bit controls the choice of odd or even parity, the UPREN bit controls the parity on/off function and the USTOPS bit decides whether one or two stop bits are to be used. The following table shows various formats for data transmission. The address bit, which is the MSB of the data byte, identifies the frame as an address character or data if the address detect function is enabled. The number of stop bits, which can be either one or two, is independent of the data length and is only used for the transmitter. There is only one stop bit for the receiver.

Start Bit	Data Bits	Address Bit	Parity Bit	Stop Bit
Example of 8-bit Data Formats				
1	8	0	0	1
1	7	0	1	1
1	7	1	0	1
Example of 9-bit Data Formats				
1	9	0	0	1
1	8	0	1	1
1	8	1	0	1

Transmitter Receiver Data Format

The following diagram shows the transmit and receive waveforms for both 8-bit and 9-bit data formats.

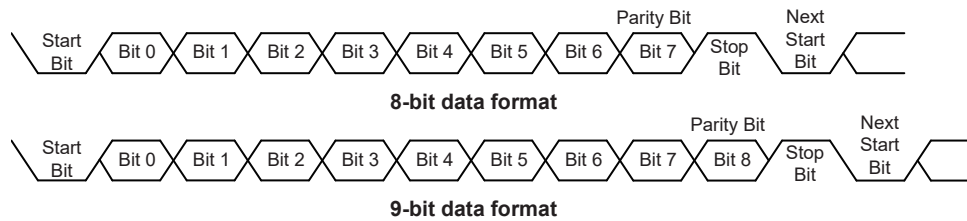

UART Transmitter

Data word lengths of either 8 or 9 bits can be selected by programming the UBNO bit in the UUCR1 register. When UBNO bit is set, the word length will be set to 9 bits. In this case the 9th bit, which is the MSB, needs to be stored in the UTX8 bit in the UUCR1 register. At the transmitter core lies the Transmitter Shift Register, more commonly known as the TSR, whose data is obtained from the transmit data register, which is known as the UTXR_RXR register. The data to be transmitted is loaded into this UTXR_RXR register by the application program. The TSR register is not written to with new data until the stop bit from the previous transmission has been sent out. As soon as this stop bit has been transmitted, the TSR can then be loaded with new data from the UTXR_RXR register, if it is available. It should be noted that the TSR register, unlike many other registers, is not directly mapped into the Data Memory area and as such is not available to the application program for direct read/write operations. An actual transmission of data will normally be enabled when the UTXEN bit is set, but the data will not be transmitted until the UTXR_RXR register has been loaded with data and the baud rate generator has defined a shift clock source. However, the transmission can also be initiated by first loading data into the UTXR_RXR register, after which the UTXEN bit can be set. When a transmission of data begins, the TSR is normally empty, in which case a transfer to the UTXR_RXR register will result in an immediate transfer to the TSR. If during a transmission the UTXEN bit is cleared, the transmission will immediately cease and the transmitter will be reset. The TX output pin can then be configured as the I/O or other pin-shared function by configuring the corresponding pin-shared control bits.

Transmitting Data

When the UART is transmitting data, the data is shifted on the TX pin from the shift register, with the least significant bit first. In the transmit mode, the UTXR_RXR register forms a buffer between the internal bus and the transmitter shift register. It should be noted that if 9-bit data format has been selected, then the MSB will be taken from the UTX8 bit in the UUCR1 register. The steps to initiate a data transfer can be summarized as follows:

- Make the correct selection of the UBNO, UPRT, UPREN and USTOPS bits to define the required word length, parity type and number of stop bits.

- Setup the UBRG register to select the desired baud rate.
- Set the UTXEN bit to ensure that the TX pin is used as a UART transmitter pin.
- Access the UUSR register and write the data that is to be transmitted into the UTXR_RXR register. Note that this step will clear the UTXIF bit.

This sequence of events can now be repeated to send additional data.

It should be noted that when UTXIF=0, data will be inhibited from being written to the UTXR_RXR register. Clearing the UTXIF flag is always achieved using the following software sequence:

1. A UUSR register access
2. A UTXR_RXR register write execution

The read-only UTXIF flag is set by the UART hardware and if set indicates that the UTXR_RXR register is empty and that other data can now be written into the UTXR_RXR register without overwriting the previous data. If the UTEIE bit is set then the UTXIF flag will generate an interrupt.

During a data transmission, a write instruction to the UTXR_RXR register will place the data into the UTXR_RXR register, which will be copied to the shift register at the end of the present transmission. When there is no data transmission in progress, a write instruction to the UTXR_RXR register will place the data directly into the shift register, resulting in the commencement of data transmission, and the UTXIF bit being immediately set. When a frame transmission is complete, which happens after stop bits are sent or after the break frame, the UTIDLE bit will be set. To clear the UTIDLE bit the following software sequence is used:

1. A UUSR register access
2. A UTXR_RXR register write execution

Note that both the UTXIF and UTIDLE bits are cleared by the same software sequence.

Transmit Break

If the UTXBRK bit is set then break characters will be sent on the next transmission. Break character transmission consists of a start bit, followed by $13 \times N$ '0' bits and stop bits, where $N=1, 2,$ etc. If a break character is to be transmitted then the UTXBRK bit must be first set by the application program, and then cleared to generate the stop bits. Transmitting a break character will not generate a transmit interrupt. Note that a break condition length is at least 13 bits long. If the UTXBRK bit is continually kept at a logic high level then the transmitter circuitry will transmit continuous break characters. After the application program has cleared the UTXBRK bit, the transmitter will finish transmitting the last break character and subsequently send out one or two stop bits. The automatic logic highs at the end of the last break character will ensure that the start bit of the next frame is recognized.

UART Receiver

The UART is capable of receiving word lengths of either 8 or 9 bits. If the UBNO bit is set, the word length will be set to 9 bits with the MSB being stored in the URX8 bit of the UUCR1 register. At the receiver core lies the Receive Serial Shift Register, commonly known as the RSR. The data which is received on the RX external input pin is sent to the data recovery block. The data recovery block operating speed is 16 times that of the baud rate, while the main receive serial shifter operates at the baud rate. After the RX pin is sampled for the stop bit, the received data in RSR is transferred to the receive data register, if the register is empty. The data which is received on the external RX input pin is sampled three times by a majority detect circuit to determine the logic level that has been placed onto the RX pin. It should be noted that the RSR register, unlike many other registers, is not directly mapped into the Data Memory area and as such is not available to the application program for direct read/write operations.

Receiving Data

When the UART receiver is receiving data, the data is serially shifted in on the external RX input pin, LSB first. In the read mode, the UTXR_RXR register forms a buffer between the internal bus and the receiver shift register. The UTXR_RXR register is a two byte deep FIFO data buffer, where two bytes can be held in the FIFO while a third byte can continue to be received. Note that the application program must ensure that the data is read from UTXR_RXR before the third byte has been completely shifted in, otherwise this third byte will be discarded and an overrun error UOERR will be subsequently indicated. The steps to initiate a data transfer can be summarized as follows:

- Make the correct selection of UBNO, UPRT and UPREN bits to define the word length, parity type.
- Setup the UBRG register to select the desired baud rate.
- Set the URXEN bit to ensure that the RX pin is used as a UART receiver pin.

At this point the receiver will be enabled which will begin to look for a start bit.

When a character is received the following sequence of events will occur:

- The URXIF bit in the UUSR register will be set when the UTXR_RXR register has data available. There will be at most one more character available before an overrun error occurs.
- When the contents of the shift register have been transferred to the UTXR_RXR register, then if the URIE bit is set, an interrupt will be generated.
- If during reception, a frame error, noise error, parity error, or an overrun error has been detected, then the error flags can be set.

The URXIF bit can be cleared using the following software sequence:

1. A UUSR register access
2. A UTXR_RXR register read execution

Receive Break

Any break character received by the UART will be managed as a framing error. The receiver will count and expect a certain number of bit times as specified by the values programmed into the UBNO bit plus one stop bit. If the break is much longer than 13 bit times, the reception will be considered as complete after the number of bit times specified by UBNO plus one stop bit. The URXIF bit is set, UFERR is set, zeros are loaded into the receive data register, interrupts are generated if appropriate and the URIDLE bit is set. A break is regarded as a character that contains only zeros with the UFERR flag set. If a long break signal has been detected, the receiver will regard it as a data frame including a start bit, data bits and the invalid stop bit and the UFERR flag will be set. The receiver must wait for a valid stop bit before looking for the next start bit. The receiver will not make the assumption that the break condition on the line is the next start bit. The break character will be loaded into the buffer and no further data will be received until stop bits are received. It should be noted that the URIDLE read only flag will go high when the stop bits have not yet been received. The reception of a break character on the UART registers will result in the following:

- The framing error flag, UFERR, will be set.
- The receive data register, UTXR_RXR, will be cleared.
- The UOERR, UNF, UPERR, URIDLE or URXIF flags will possibly be set.

Idle Status

When the receiver is reading data, which means it will be in between the detection of a start bit and the reading of a stop bit, the receiver status flag in the UUSR register, otherwise known as the URIDLE flag, will have a zero value. In between the reception of a stop bit and the detection of the next start bit, the URIDLE flag will have a high value, which indicates the receiver is in an idle condition.

Receiver Interrupt

The read only receive interrupt flag URXIF in the UUSR register is set by an edge generated by the receiver. An interrupt is generated if URIE=1, when a word is transferred from the Receive Shift Register, RSR, to the Receive Data Register, UTXR_RXR. An overrun error can also generate an interrupt if URIE=1.

Managing Receiver Errors

Several types of reception errors can occur within the UART module, the following section describes the various types and how they are managed by the UART.

Overrun Error – UOERR

The UTXR_RXR register is composed of a two byte deep FIFO data buffer, where two bytes can be held in the FIFO register, while a third byte can continue to be received. Before this third byte has been entirely shifted in, the data should be read from the UTXR_RXR register. If this is not done, the overrun error flag UOERR will be consequently indicated.

In the event of an overrun error occurring, the following will happen:

- The UOERR flag in the UUSR register will be set.
- The UTXR_RXR contents will not be lost.
- The shift register will be overwritten.
- An interrupt will be generated if the URIE bit is set.

The UOERR flag can be cleared by an access to the UUSR register followed by a read to the UTXR_RXR register.

Noise Error – UNF

Over-sampling is used for data recovery to identify valid incoming data and noise. If noise is detected within a frame the following will occur:

- The read only noise flag, UNF, in the UUSR register will be set on the rising edge of the URXIF bit.
- Data will be transferred from the Shift register to the UTXR_RXR register.
- No interrupt will be generated. However this bit rises at the same time as the URXIF bit which itself generates an interrupt.

Note that the UNF flag is reset by a UUSR register read operation followed by a UTXR_RXR register read operation.

Framing Error – UFERR

The read only framing error flag, UFERR, in the UUSR register, is set if a zero is detected instead of stop bits. If two stop bits are selected, both stop bits must be high; otherwise the UFERR flag will be set. The UFERR flag and the received data will be recorded in the UUSR and UTXR_RXR registers respectively, and the flag is cleared in any reset.

Parity Error – UPERR

The read only parity error flag, UPERR, in the UUSR register, is set if the parity of the received word is incorrect. This error flag is only applicable if the parity is enabled, UPREN=1, and if the parity type, odd or even is selected. The read only UPERR flag and the received data will be recorded in the UUSR and UTXR_RXR registers respectively. It is cleared on any reset, it should be noted that the flags, UFERR and UPERR, in the UUSR register should first be read by the application program before reading the data word.

UART Interrupt Structure

Several individual UART conditions can trigger an USIM interrupt. When these conditions exist, a low pulse will be generated to get the attention of the microcontroller. These conditions are a transmitter data register empty, transmitter idle, receiver data available, receiver overrun, address detect and an RX pin wake-up. When any of these conditions are created, if the global interrupt enable bit and the USIM interrupt control bit are enabled and the stack is not full, the program will jump to its corresponding interrupt vector where it can be serviced before returning to the main program. Four of these conditions have the corresponding UUSR register flags which will generate an USIM interrupt if its associated interrupt enable control bit in the UUCR2 register is set. The two transmitter interrupt conditions have their own corresponding enable control bits, while the two receiver interrupt conditions have a shared enable control bit. These enable bits can be used to mask out individual USIM UART mode interrupt sources.

The address detect condition, which is also an USIM UART mode interrupt source, does not have an associated flag, but will generate an USIM interrupt when an address detect condition occurs if its function is enabled by setting the UADDEN bit in the UUCR2 register. An RX pin wake-up, which is also an USIM UART mode interrupt source, does not have an associated flag, but will generate an USIM interrupt if the UART clock (f_{IH}) source is switched off and the UWAKE and URIE bits in the UUCR2 register are set when a falling edge on the RX pin occurs. Note that in the event of an RX wake-up interrupt occurring, there will be a certain period of delay, commonly known as the System Start-up Time, for the oscillator to restart and stabilize before the system resumes normal operation.

Note that the UUSR register flags are read only and cannot be cleared or set by the application program, neither will they be cleared when the program jumps to the corresponding interrupt servicing routine, as is the case for some of the other interrupts. The flags will be cleared automatically when certain actions are taken by the UART, the details of which are given in the UART register section. The overall UART interrupt can be disabled or enabled by the USIM interrupt enable control bit in the interrupt control register of the microcontroller to decide whether the interrupt requested by the UART module is masked out or allowed.

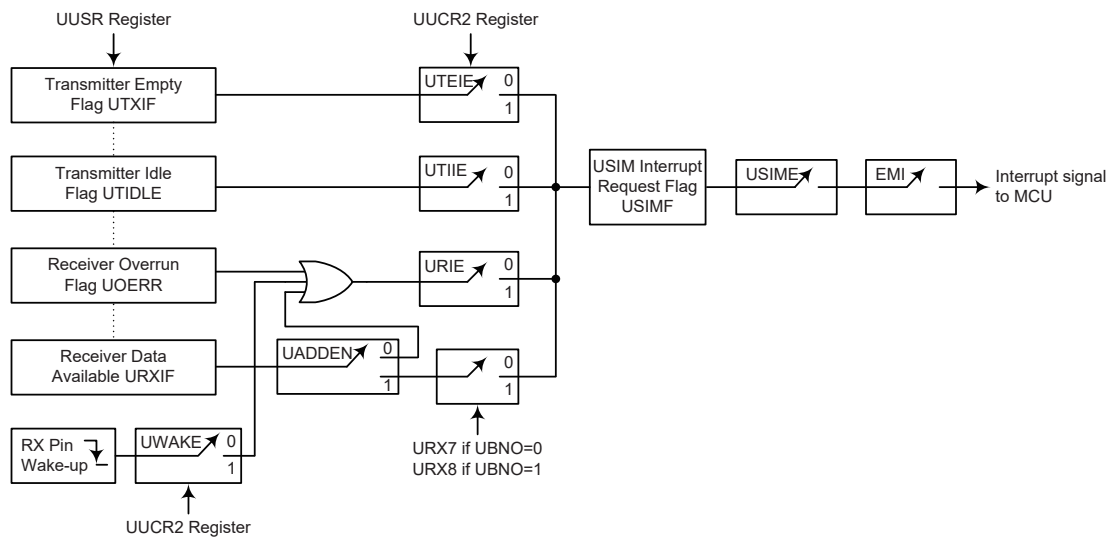

UART Interrupt Structure

Address Detect Mode

Setting the Address Detect Mode bit, UADDEN, in the UUCR2 register, enables this special mode. If this bit is enabled then an additional qualifier will be placed on the generation of a Receiver Data Available interrupt, which is requested by the URXIF flag. If the UADDEN bit is enabled, then when data is available, an interrupt will only be generated, if the highest received bit has a high value. Note that the USIME and EMI interrupt enable bits must also be enabled for correct interrupt generation. This highest address bit is the 9th bit if UBNO=1 or the 8th bit if UBNO=0. If this bit is high, then the received word will be defined as an address rather than data. A Data Available interrupt will be generated every time the last bit of the received word is set. If the UADDEN bit is not enabled, then a Receiver Data Available interrupt will be generated each time the URXIF flag is set, irrespective of the data last bit status. The address detect mode and parity enable are mutually exclusive functions. Therefore if the address detect mode is enabled, then to ensure correct operation, the parity function should be disabled by resetting the parity enable bit UPREN to zero.

UADDEN	Bit 9 if UBNO=1, Bit 8 if UBNO=0	USIM Interrupt Generated
0	0	√
	1	√
1	0	×
	1	√

UADDEN Bit Function

UART Power Down and Wake-up

When the UART clock (f_{H}) is off, the UART will cease to function, all clock sources to the module are shutdown. If the UART clock (f_{H}) is off while a transmission is still in progress, then the transmission will be paused until the UART clock source derived from the microcontroller is activated. In a similar way, if the MCU enters the IDLE or SLEEP mode while receiving data, then the reception of data will likewise be paused. When the MCU enters the IDLE or SLEEP mode, note that the UUSR, UUCR1, UUCR2, transmit and receive registers, as well as the UBRG register will not be affected. It is recommended to make sure first that the UART data transmission or reception has been finished before the microcontroller enters the IDLE or SLEEP mode.

The UART function contains a receiver RX pin wake-up function, which is enabled or disabled by the UWAKE bit in the UUCR2 register. If this bit, along with the UART mode selection bit, UMD, the UART enable bit, UREN, the receiver enable bit, URXEN and the receiver interrupt bit, URIE, are all set when the UART clock (f_{H}) is off, then a falling edge on the RX pin will trigger an RX pin wake-up UART interrupt. Note that as it takes certain system clock cycles after a wake-up, before normal microcontroller operation resumes, any data received during this time on the RX pin will be ignored.

For a UART wake-up interrupt to occur, in addition to the bits for the wake-up being set, the global interrupt enable bit, EMI, and the USIM interrupt enable bit, USIME, must be set. If the EMI and USIME bits are not set then only a wake up event will occur and no interrupt will be generated. Note also that as it takes certain system clock cycles after a wake-up before normal microcontroller resumes, the USIM interrupt will not be generated until after this time has elapsed.

Serial Peripheral Interface – SPIA

The device contains an independent SPI function. It is important not to confuse this independent SPI function with the additional one contained within the combined USIM function, which is described in another section of this datasheet. This independent SPI function will carry the name SPIA to distinguish it from the other one in the USIM.

The SPIA interface is often used to communicate with external peripheral devices such as sensors, Flash or EEPROM memory devices etc. Originally developed by Motorola, the four line SPIA interface is a synchronous serial data interface that has a relatively simple communication protocol simplifying the programming requirements when communicating with external hardware devices.

The communication is full duplex and operates as a slave/master type, where the device can be either master or slave. Although the SPIA interface specification can control multiple slave devices from a single master, however the device is provided with only one \overline{SCSA} pin. If the master needs to control multiple slave devices from a single master, the master can use I/O pins to select the slave devices.

SPIA Interface Operation

The SPIA interface is a full duplex synchronous serial data link. It is a four line interface with pin names SDIA, SDOA, SCKA and \overline{SCSA} . Pins SDIA and SDOA are the Serial Data Input and Serial Data Output lines, the SCKA pin is the Serial Clock line and \overline{SCSA} is the Slave Select line. As the SPIA interface pins are pin-shared with normal I/O pins, the SPIA interface must first be enabled by configuring the corresponding selection bits in the pin-shared function selection registers. The SPIA can be disabled or enabled using the SPIAEN bit in the SPIAC0 register. Communication between devices connected to the SPIA interface is carried out in a slave/master mode with all data transfer initiations being implemented by the master. The Master also controls the clock signal. As the device only contains a single \overline{SCSA} pin only one slave device can be utilized.

The \overline{SCSA} pin is controlled by the application program, set the \overline{SACSEN} bit to “1” to enable the \overline{SCSA} pin function and clear the \overline{SACSEN} bit to “0” to place the \overline{SCSA} pin into a floating condition.

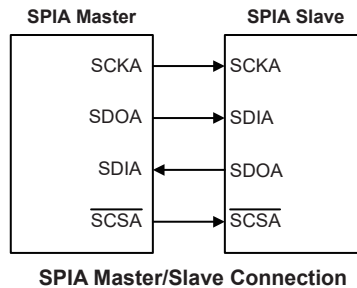

The SPIA function in the device offers the following features:

- Full duplex synchronous data transfer
- Both Master and Slave modes
- LSB first or MSB first data transmission modes
- Transmission complete flag
- Rising or falling active clock edge

The status of the SPIA interface pins is determined by a number of factors such as whether the device is in the master or slave mode and upon the condition of certain control bits such as \overline{SACSEN} and SPIAEN.

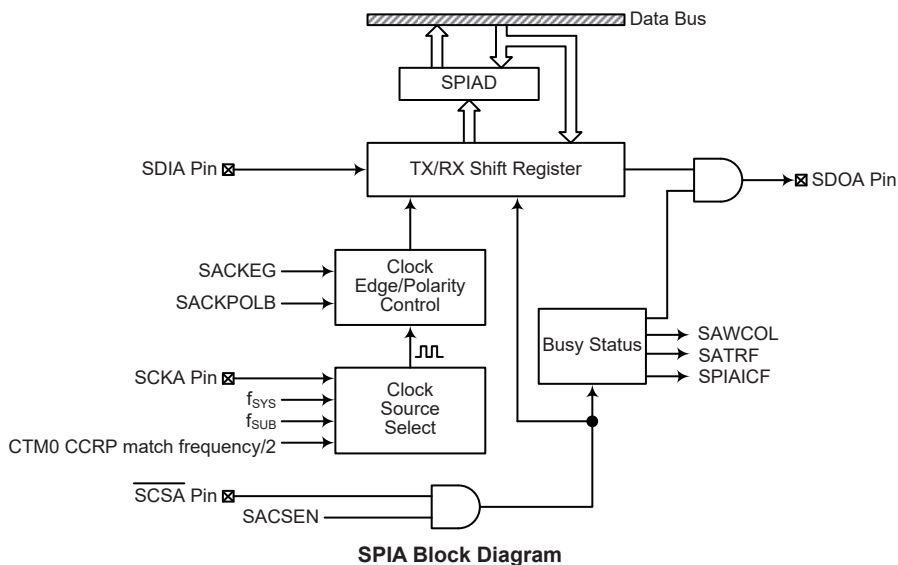

SPIA Registers

There are three internal registers which control the overall operation of the SPIA interface. These are the SPIAD data register and two registers, SPIAC0 and SPIAC1.

Register Name	Bit							
	7	6	5	4	3	2	1	0
SPIAC0	SASPI2	SASPI1	SASPI0	—	—	—	SPIAEN	SPIAICF
SPIAC1	—	—	SACKPOLB	SACKEG	SAMLS	SACSEN	SAWCOL	SATRF
SPIAD	D7	D6	D5	D4	D3	D2	D1	D0

SPIA Register List

SPIA Data Register

The SPIAD register is used to store the data being transmitted and received. Before the device writes data to the SPIA bus, the actual data to be transmitted must be placed in the SPIAD register. After the data is received from the SPIA bus, the device can read it from the SPIAD register. Any transmission or reception of data from the SPIA bus must be made via the SPIAD register.

• SPIAD Register

Bit	7	6	5	4	3	2	1	0
Name	D7	D6	D5	D4	D3	D2	D1	D0
R/W	R/W	R/W	R/W	R/W	R/W	R/W	R/W	R/W
POR	x	x	x	x	x	x	x	x

"x": unknown

Bit 7~0 **D7~D0**: SPIA data register bit 7~bit 0

SPIA Control Registers

There are also two control registers for the SPIA interface, SPIAC0 and SPIAC1. The SPIAC0 register is used to control the enable/disable function and to set the data transmission clock frequency. The SPIAC1 register is used for other control functions such as LSB/MSB selection, write collision flag etc.

• **SPIAC0 Register**

Bit	7	6	5	4	3	2	1	0
Name	SASPI2	SASPI1	SASPI0	—	—	—	SPIAEN	SPIAICF
R/W	R/W	R/W	R/W	—	—	—	R/W	R/W
POR	1	1	1	—	—	—	0	0

- Bit 7~5 **SASPI2~SASPI0**: SPIA Operating Mode Control
 000: SPIA master mode; SPIA clock is $f_{SYS}/4$
 001: SPIA master mode; SPIA clock is $f_{SYS}/16$
 010: SPIA master mode; SPIA clock is $f_{SYS}/64$
 011: SPIA master mode; SPIA clock is f_{SUB}
 100: SPIA master mode; SPIA clock is CTM0 CCRP match frequency/2
 101: SPIA slave mode
 11x: Unimplemented
- These bits are used to control the SPIA Master/Slave selection and the SPIA Master clock frequency. The SPIA clock is a function of the system clock but can also be chosen to be sourced from CTM0 and f_{SUB} . If the SPIA Slave Mode is selected then the clock will be supplied by an external Master device.
- Bit 4~2 Unimplemented, read as “0”
- Bit 1 **SPIAEN**: SPIA Enable Control
 0: Disable
 1: Enable
- The bit is the overall on/off control for the SPIA interface. When the SPIAEN bit is cleared to zero to disable the SPIA interface, the SDIA, SDOA, SCKA and SCSA lines will lose their SPIA function and the SPIA operating current will be reduced to a minimum value. When the bit is high the SPIA interface is enabled.
- Bit 0 **SPIAICF**: SPIA Incomplete Flag
 0: SPIA incomplete condition is not occurred
 1: SPIA incomplete condition is occurred
- This bit is only available when the SPIA is configured to operate in an SPIA slave mode. If the SPIA operates in the slave mode with the SPIAEN and SACSSEN bits both being set high but the SCSA line is pulled high by the external master device before the SPIA data transfer is completely finished, the SPIAICF bit will be set high together with the SATRF bit. When this condition occurs, the corresponding interrupt will occur if the interrupt function is enabled. However, the SATRF bit will not be set high if the SPIAICF bit is set high by software application program.

• **SPIAC1 Register**

Bit	7	6	5	4	3	2	1	0
Name	—	—	SACKPOLB	SACKEG	SAMLS	SACSSEN	SAWCOL	SATRF
R/W	—	—	R/W	R/W	R/W	R/W	R/W	R/W
POR	—	—	0	0	0	0	0	0

- Bit 7~6 Unimplemented, read as “0”
- Bit 5 **SACKPOLB**: SPIA clock line base condition selection
 0: The SCKA line will be high when the clock is inactive
 1: The SCKA line will be low when the clock is inactive
- The SACKPOLB bit determines the base condition of the clock line, if the bit is high, then the SCKA line will be low when the clock is inactive. When the SACKPOLB bit is low, then the SCKA line will be high when the clock is inactive.
- Bit 4 **SACKEG**: SPIA SCKA clock active edge type selection
 SACKPOLB=0
 0: SCKA has high base level with data capture on SCKA rising edge
 1: SCKA has high base level with data capture on SCKA falling edge
 SACKPOLB=1

- 0: SCKA has low base level with data capture on SCKA falling edge
- 1: SCKA has low base level with data capture on SCKA rising edge

The SACKEG and SACKPOLB bits are used to setup the way that the clock signal outputs and inputs data on the SPIA bus. These two bits must be configured before a data transfer is executed otherwise an erroneous clock edge may be generated. The SACKPOLB bit determines the base condition of the clock line, if the bit is high, then the SCKA line will be low when the clock is inactive. When the SACKPOLB bit is low, then the SCKA line will be high when the clock is inactive. The SACKEG bit determines active clock edge type which depends upon the condition of the SACKPOLB bit.

- Bit 3 **SAMLS**: SPIA data shift order
 0: LSB first
 1: MSB first

This is the data shift select bit and is used to select how the data is transferred, either MSB or LSB first. Setting the bit high will select MSB first and low for LSB first.

- Bit 2 **SACSEN**: SPIA \overline{SCSA} pin control
 0: Disable
 1: Enable

The \overline{SACSEN} bit is used as an enable/disable for the \overline{SCSA} pin. If this bit is low, then the \overline{SCSA} pin will be disabled and placed into a floating condition. If the bit is high the \overline{SCSA} pin will be enabled and used as a select pin.

- Bit 1 **SAWCOL**: SPIA write collision flag
 0: No collision
 1: Collision

The SAWCOL flag is used to detect if a data collision has occurred. If this bit is high it means that data has been attempted to be written to the SPIAD register during a data transfer operation. This writing operation will be ignored if data is being transferred. The bit can be cleared to zero by the application program.

- Bit 0 **SATRF**: SPIA Transmit/Receive complete flag
 0: SPIA data is being transferred
 1: SPIA data transmission is completed

The SATRF bit is the Transmit/Receive Complete flag and is set “1” automatically when an SPIA data transmission is completed, but must set to zero by the application program. It can be used to generate an interrupt.

SPIA Communication

After the SPIA interface is enabled by setting the SPIAEN bit high, then in the Master Mode, when data is written to the SPIAD register, transmission/reception will begin simultaneously. When the data transfer is complete, the SATRF flag will be set automatically, but must be cleared using the application program. In the Slave Mode, when the clock signal from the master has been received, any data in the SPIAD register will be transmitted and any data on the SDIA pin will be shifted into the SPIAD register.

The master should output an \overline{SCSA} signal to enable the slave device before a clock signal is provided. The slave data to be transferred should be well prepared at the appropriate moment relative to the SCKA signal depending upon the configurations of the SACKPOLB bit and SACKEG bit. The accompanying timing diagram shows the relationship between the slave data and SACK signal for various configurations of the SACKPOLB and SACKEG bits. The SPIA will continue to function if the clock source used by the SPIA interface is still active.

The SPIA will continue to function in certain IDLE Modes if the clock source used by the SPIA interface is still active.

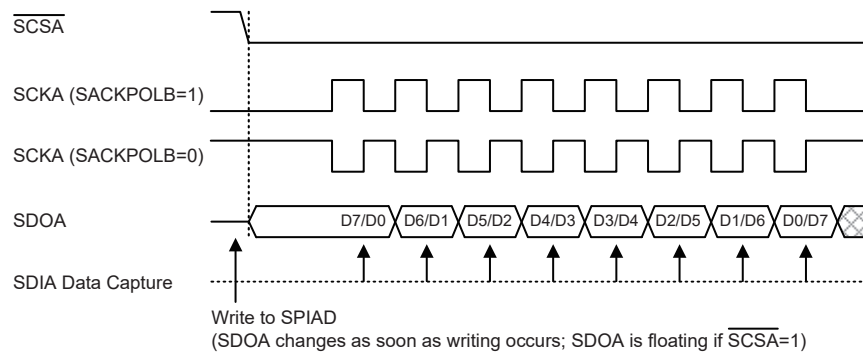
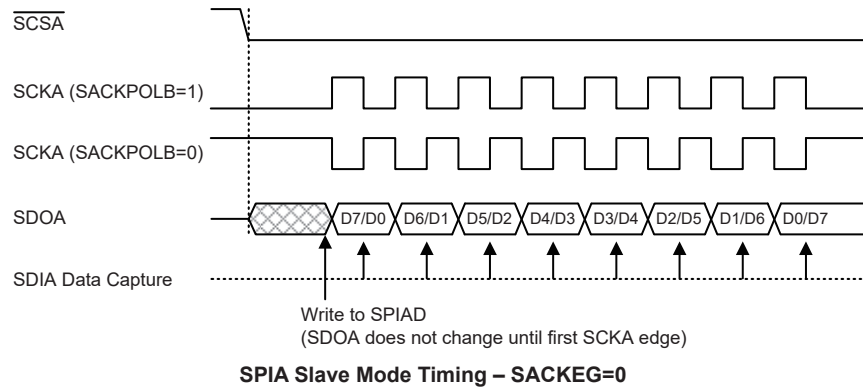
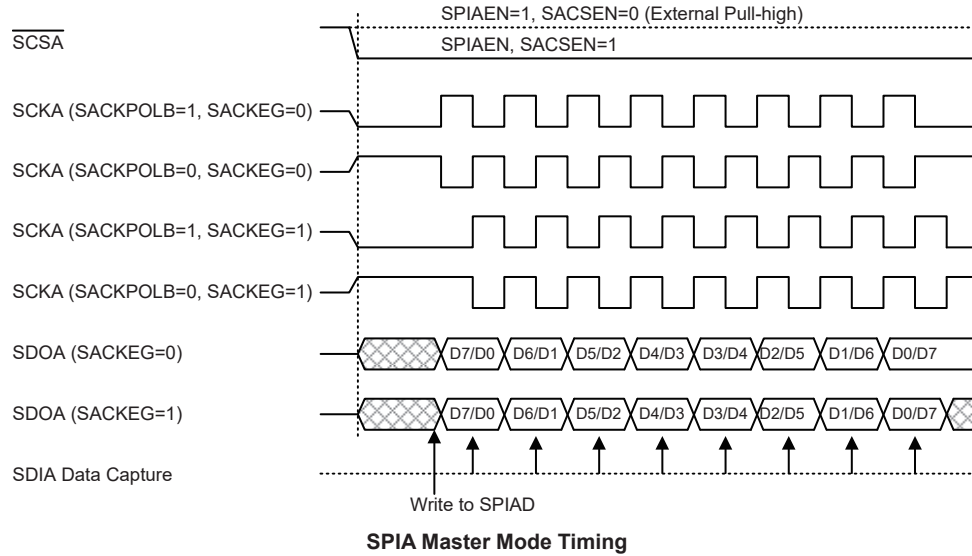

Note: For SPIA slave mode, if SPIAEN=1 and SACSSEN=0, SPIA is always enabled and ignores the SCSA level.

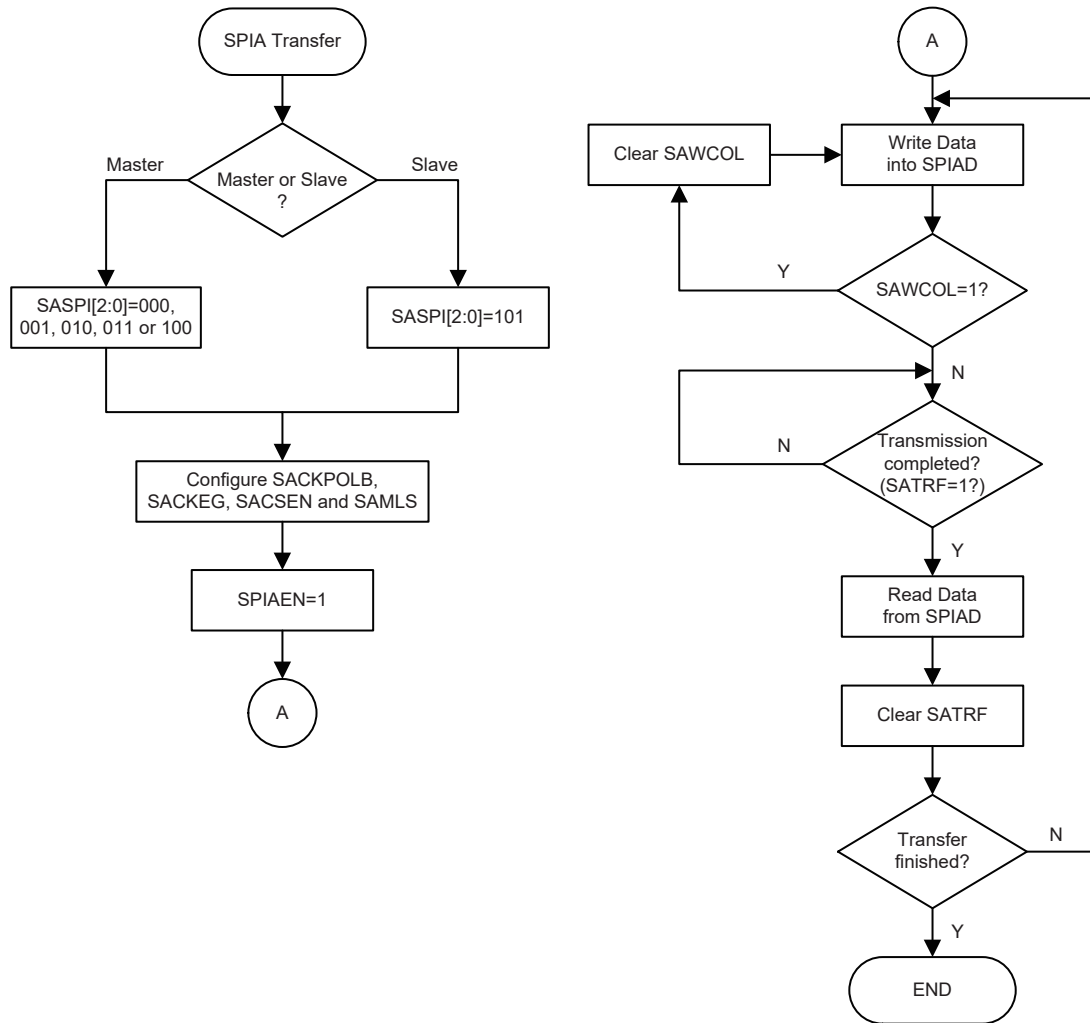

SPIA Transfer Control Flow Chart

SPIA Bus Enable/Disable

To enable the SPIA bus, set $SACSEN=1$ and $\overline{SCSA}=0$, then wait for data to be written into the SPIAD (TXRX buffer) register. For the Master Mode, after data has been written to the SPIAD (TXRX buffer) register, then transmission or reception will start automatically. When all the data has been transferred the SATRF bit should be set. For the Slave Mode, when clock pulses are received on SCKA, data in the TXRX buffer will be shifted out or data on SDIA will be shifted in.

When the SPIA bus is disabled, SCKA, SDIA, SDOA, \overline{SCSA} can become I/O pins or other pin-shared functions using the corresponding pin-shared control bits.

SPIA Operation Steps

All communication is carried out using the 4-line interface for either Master or Slave Mode.

The SACSEN bit in the SPIAC1 register controls the overall function of the SPIA interface. Setting this bit high will enable the SPIA interface by allowing the \overline{SCSA} line to be active, which can then be used to control the SPIA interface. If the SACSEN bit is low, the SPIA interface will be disabled and the \overline{SCSA} line will be in a floating condition and can therefore not be used for control of the SPIA interface. If the SACSEN bit and the SPIAEN bit in the SPIAC0 register are set high, this will place the SDIA line in a floating condition and the SDOA line high. If in Master Mode the SCKA line will be either high or low depending upon the clock polarity selection bit SACKPOLB in the SPIAC1 register. If in Slave Mode the SCKA line will be in a floating condition. If SPIAEN is low then the bus will be disabled and \overline{SCSA} , SDIA, SDOA and SCKA will all become I/O pins or the other functions using the corresponding pin-shared control bits. In the Master Mode the Master will always generate the clock signal. The clock and data transmission will be initiated after data has been written into the SPIAD register. In the Slave Mode, the clock signal will be received from an external master device for both data transmission and reception. The following sequences show the order to be followed for data transfer in both Master and Slave Mode.

Master Mode:

- Step 1
Select the clock source and Master mode using the SASPI2~SASPI0 bits in the SPIAC0 control register.
- Step 2
Setup the SACSEN bit and setup the SAMLS bit to choose if the data is MSB or LSB first, this must be same as the Slave device.
- Step 3
Setup the SPIAEN bit in the SPIAC0 control register to enable the SPIA interface.
- Step 4
For write operations: write the data to the SPIAD register, which will actually place the data into the TXRX buffer. Then use the SCKA and \overline{SCSA} lines to output the data. After this go to step 5.
For read operations: the data transferred in on the SDIA line will be stored in the TXRX buffer until all the data has been received at which point it will be latched into the SPIAD register.
- Step 5
Check the SAWCOL bit if set high then a collision error has occurred so return to step 4. If equal to zero then go to the following step.
- Step 6
Check the SATRF bit or wait for a SPIA serial bus interrupt.

- Step 7
Read data from the SPIAD register.
- Step 8
Clear SATRF.
- Step 9
Go to step 4.

Slave Mode:

- Step 1
Select the SPIA Slave mode using the SASPI2~SASPI0 bits in the SPIAC0 control register.
- Step 2
Setup the SACSEN bit and setup the SAMLS bit to choose if the data is MSB or LSB first, this setting must be the same with the Master device.
- Step 3
Setup the SPIAEN bit in the SPIAC0 control register to enable the SPIA interface.
- Step 4
For write operations: write the data to the SPIAD register, which will actually place the data into the TXRX buffer. Then wait for the master clock SCKA and \overline{SCSA} signal. After this, go to step 5. For read operations: the data transferred in on the SDIA line will be stored in the TXRX buffer until all the data has been received at which point it will be latched into the SPIAD register.
- Step 5
Check the SAWCOL bit if set high then a collision error has occurred so return to step 4. If equal to zero then go to the following step.
- Step 6
Check the SATRF bit or wait for a SPIA serial bus interrupt.
- Step 7
Read data from the SPIAD register.
- Step 8
Clear SATRF.
- Step 9
Go to step 4.

Error Detection

The SAWCOL bit in the SPIAC1 register is provided to indicate errors during data transfer. The bit is set by the SPIA serial Interface but must be cleared by the application program. This bit indicates a data collision has occurred which happens if a write to the SPIAD register takes place during a data transfer operation and will prevent the write operation from continuing.

Interrupts

Interrupts are an important part of any microcontroller system. When an external event or an internal function such as a Timer Module requires microcontroller attention, their corresponding interrupt will enforce a temporary suspension of the main program allowing the microcontroller to direct attention to their respective needs. The device contains several external interrupt and internal interrupt functions. The external interrupts are generated by the action of the external INT0~INT3 pins, while the internal interrupts are generated by various internal functions such as the Timer Modules (TM), Time Bases, Low Voltage Detector (LVD), EEPROM, A/D Converter, Electronic Paper Display (EPD), SPIA and the USIM module.

Interrupt Registers

Overall interrupt control, which basically means the setting of request flags when certain microcontroller conditions occur and the setting of interrupt enable bits by the application program, is controlled by a series of registers, located in the Special Purpose Data Memory. The registers fall into three categories. The first is the INTC0~INTC3 registers which setup the primary interrupts, the second is the MF10~MF12 registers which setup the Multi-function interrupts. Finally there is an INTEG register to setup the external interrupts trigger edge type.

Each register contains a number of enable bits to enable or disable individual registers as well as interrupt flags to indicate the presence of an interrupt request. The naming convention of these follows a specific pattern. First is listed an abbreviated interrupt type, then the (optional) number of that interrupt followed by either an “E” for enable/disable bit or “F” for request flag.

Function	Enable Bit	Request Flag	Note
Global	EMI	—	—
INTn Pin	INTnE	INTnF	n=0~3
Multi-function	MFnE	MFnF	n=0~2
Time Base	TBnE	TBnF	n=0~1
LVD	LVE	LVF	—
EEPROM	DEE	DEF	—
USIM	USIME	USIMF	—
SPIA	SPIAE	SPIAF	—
A/D Converter	ADE	ADF	—
EPD	EPDRFF	EPDRFE	—
	EPDCPF	EPDCPE	—
TM	CTMnPE	CTMnPF	n=0~1
	CTMnAE	CTMnAF	
	STMPE	STMPF	—
	STMAE	STMAF	

Interrupt Register Bit Naming Conventions

Register Name	Bit							
	7	6	5	4	3	2	1	0
INTEG	INT3S1	INT3S0	INT2S1	INT2S0	INT1S1	INT1S0	INT0S1	INT0S0
INTC0	—	USIMF	INT1F	INT0F	USIME	INT1E	INT0E	EMI
INTC1	MF2F	MF1F	MF0F	SPIAF	MF2E	MF1E	MF0E	SPIAE
INTC2	INT3F	INT2F	TB1F	TB0F	INT3E	INT2E	TB1E	TB0E
INTC3	—	EPDRFF	EPDCPF	ADF	—	EPDRFE	EPDCPE	ADE
MF10	CTM1AF	CTM1PF	CTM0AF	CTM0PF	CTM1AE	CTM1PE	CTM0AE	CTM0PE
MF11	—	—	STMAF	STMPF	—	—	STMAE	STMPE
MF12	—	—	DEF	LVF	—	—	DEE	LVE

Interrupt Register List

• **INTEG Register**

Bit	7	6	5	4	3	2	1	0
Name	INT3S1	INT3S0	INT2S1	INT2S0	INT1S1	INT1S0	INT0S1	INT0S0
R/W	R/W	R/W	R/W	R/W	R/W	R/W	R/W	R/W
POR	0	0	0	0	0	0	0	0

- Bit 7~6 **INT3S1~INT3S0**: Interrupt Edge Control for INT3 Pin
00: Disable
01: Rising edge
10: Falling edge
11: Rising and falling edges
- Bit 5~4 **INT2S1~INT2S0**: Interrupt Edge Control for INT2 Pin
00: Disable
01: Rising edge
10: Falling edge
11: Rising and falling edges
- Bit 3~2 **INT1S1~INT1S0**: Interrupt Edge Control for INT1 Pin
00: Disable
01: Rising edge
10: Falling edge
11: Rising and falling edges
- Bit 1~0 **INT0S1~INT0S0**: Interrupt Edge Control for INT0 Pin
00: Disable
01: Rising edge
10: Falling edge
11: Rising and falling edges

• **INTC0 Register**

Bit	7	6	5	4	3	2	1	0
Name	—	USIMF	INT1F	INT0F	USIME	INT1E	INT0E	EMI
R/W	—	R/W	R/W	R/W	R/W	R/W	R/W	R/W
POR	—	0	0	0	0	0	0	0

- Bit 7 Unimplemented, read as “0”
- Bit 6 **USIMF**: USIM Interrupt Request Flag
0: No request
1: Interrupt request
- Bit 5 **INT1F**: External Interrupt 1 Request Flag
0: No request
1: Interrupt request
- Bit 4 **INT0F**: External Interrupt 0 Request Flag
0: No request
1: Interrupt request
- Bit 3 **USIME**: USIM Interrupt Control
0: Disable
1: Enable
- Bit 2 **INT1E**: External Interrupt 1 Control
0: Disable
1: Enable
- Bit 1 **INT0E**: External Interrupt 0 Control
0: Disable
1: Enable
- Bit 0 **EMI**: Global Interrupt Control
0: Disable
1: Enable

• **INTC1 Register**

Bit	7	6	5	4	3	2	1	0
Name	MF2F	MF1F	MF0F	SPIAF	MF2E	MF1E	MF0E	SPIAE
R/W	R/W	R/W	R/W	R/W	R/W	R/W	R/W	R/W
POR	0	0	0	0	0	0	0	0

- Bit 7 **MF2F**: Multi-function Interrupt 2 Request Flag
0: No request
1: Interrupt request
- Bit 6 **MF1F**: Multi-function Interrupt 1 Request Flag
0: No request
1: Interrupt request
- Bit 5 **MF0F**: Multi-function Interrupt 0 Request Flag
0: No request
1: Interrupt request
- Bit 4 **SPIAF**: SPIA Interrupt Request Flag
0: No request
1: Interrupt request
- Bit 3 **MF2E**: Multi-function Interrupt 2 Control
0: Disable
1: Enable
- Bit 2 **MF1E**: Multi-function Interrupt 1 Control
0: Disable
1: Enable
- Bit 1 **MF0E**: Multi-function Interrupt 0 Control
0: Disable
1: Enable
- Bit 0 **SPIAE**: SPIA Interrupt Control
0: Disable
1: Enable

• **INTC2 Register**

Bit	7	6	5	4	3	2	1	0
Name	INT3F	INT2F	TB1F	TB0F	INT3E	INT2E	TB1E	TB0E
R/W	R/W	R/W	R/W	R/W	R/W	R/W	R/W	R/W
POR	0	0	0	0	0	0	0	0

- Bit 7 **INT3F**: External Interrupt 3 Request Flag
0: No request
1: Interrupt request
- Bit 6 **INT2F**: External Interrupt 2 Request Flag
0: No request
1: Interrupt request
- Bit 5 **TB1F**: Time Base 1 Interrupt Request Flag
0: No request
1: Interrupt request
- Bit 4 **TB0F**: Time Base 0 Interrupt Request Flag
0: No request
1: Interrupt request
- Bit 3 **INT3E**: External Interrupt 3 Control
0: Disable
1: Enable

- Bit 2 **INT2E**: External Interrupt 2 Control
0: Disable
1: Enable
- Bit 1 **TB1E**: Time Base 1 Interrupt Control
0: Disable
1: Enable
- Bit 0 **TB0E**: Time Base 0 Interrupt Control
0: Disable
1: Enable

• **INTC3 Register**

Bit	7	6	5	4	3	2	1	0
Name	—	EPDRFF	EPDCPF	ADF	—	EPDRFE	EPDCPE	ADE
R/W	—	R/W	R/W	R/W	—	R/W	R/W	R/W
POR	—	0	0	0	—	0	0	0

- Bit 7 Unimplemented, read as “0”
- Bit 6 **EPDRFF**: EPD refresh finished interrupt request flag
0: No request
1: Interrupt request
- Bit 5 **EPDCPF**: EPD Charge pump voltage stable interrupt request flag
0: No request
1: Interrupt request
- Bit 4 **ADF**: A/D Converter interrupt request flag
0: No request
1: Interrupt request
- Bit 3 Unimplemented, read as “0”
- Bit 2 **EPDRFE**: EPD refresh finished interrupt control
0: Disable
1: Enable
- Bit 1 **EPDCPE**: EPD Charge pump voltage stable interrupt control
0: Disable
1: Enable
- Bit 0 **ADE**: A/D Converter interrupt control
0: Disable
1: Enable

• **MFIO Register**

Bit	7	6	5	4	3	2	1	0
Name	CTM1AF	CTM1PF	CTM0AF	CTM0PF	CTM1AE	CTM1PE	CTM0AE	CTM0PE
R/W	R/W	R/W	R/W	R/W	R/W	R/W	R/W	R/W
POR	0	0	0	0	0	0	0	0

- Bit 7 **CTM1AF**: CTM1 Comparator A match interrupt request flag
0: No request
1: Interrupt request
- Bit 6 **CTM1PF**: CTM1 Comparator P match interrupt request flag
0: No request
1: Interrupt request
- Bit 5 **CTM0AF**: CTM0 Comparator A match interrupt request flag
0: No request
1: Interrupt request

- Bit 4 **CTM0PF**: CTM0 Comparator P match interrupt request flag
 0: No request
 1: Interrupt request
- Bit 3 **CTM1AE**: CTM1 Comparator A match interrupt control
 0: Disable
 1: Enable
- Bit 2 **CTM1PE**: CTM1 Comparator P match interrupt control
 0: Disable
 1: Enable
- Bit 1 **CTM0AE**: CTM0 Comparator A match interrupt control
 0: Disable
 1: Enable
- Bit 0 **CTM0PE**: CTM0 Comparator P match interrupt control
 0: Disable
 1: Enable

• **MFI1 Register**

Bit	7	6	5	4	3	2	1	0
Name	—	—	STMAF	STMPF	—	—	STMAE	STMPE
R/W	—	—	R/W	R/W	—	—	R/W	R/W
POR	—	—	0	0	—	—	0	0

- Bit 7~6 Unimplemented, read as “0”
- Bit 5 **STMAF**: STM Comparator A match interrupt request flag
 0: No request
 1: Interrupt request
- Bit 4 **STMPF**: STM Comparator P match interrupt request flag
 0: No request
 1: Interrupt request
- Bit 3~2 Unimplemented, read as “0”
- Bit 1 **STMAE**: STM Comparator A match interrupt control
 0: Disable
 1: Enable
- Bit 0 **STMPE**: STM Comparator P match interrupt control
 0: Disable
 1: Enable

• **MFI2 Register**

Bit	7	6	5	4	3	2	1	0
Name	—	—	DEF	LVF	—	—	DEE	LVE
R/W	—	—	R/W	R/W	—	—	R/W	R/W
POR	—	—	0	0	—	—	0	0

- Bit 7~6 Unimplemented, read as “0”
- Bit 5 **DEF**: Data EEPROM interrupt request flag
 0: No request
 1: Interrupt request
- Bit 4 **LVF**: LVD interrupt request flag
 0: No request
 1: Interrupt request
- Bit 3~2 Unimplemented, read as “0”

Bit 1	DEE: Data EEPROM interrupt control 0: Disable 1: Enable
Bit 0	LVE: LVD interrupt control 0: Disable 1: Enable

Interrupt Operation

When the conditions for an interrupt event occur, such as a TM Comparator P, Comparator A match or an EEPROM Write cycle ends etc., the relevant interrupt request flag will be set. Whether the request flag actually generates a program jump to the relevant interrupt vector is determined by the condition of the interrupt enable bit. If the enable bit is set high then the program will jump to its relevant vector; if the enable bit is zero then although the interrupt request flag is set an actual interrupt will not be generated and the program will not jump to the relevant interrupt vector. The global interrupt enable bit, if cleared to zero, will disable all interrupts.

When an interrupt is generated, the Program Counter, which stores the address of the next instruction to be executed, will be transferred onto the stack. The Program Counter will then be loaded with a new address which will be the value of the corresponding interrupt vector. The microcontroller will then fetch its next instruction from this interrupt vector. The instruction at this vector will usually be a “JMP” which will jump to another section of program which is known as the interrupt service routine. Here is located the code to control the appropriate interrupt. The interrupt service routine must be terminated with a “RETI”, which retrieves the original Program Counter address from the stack and allows the microcontroller to continue with normal execution at the point where the interrupt occurred.

The various interrupt enable bits, together with their associated request flags, are shown in the accompanying diagrams with their order of priority. Some interrupt sources have their own individual vector while others share the same multi-function interrupt vector. Once an interrupt subroutine is serviced, all the other interrupts will be blocked, as the global interrupt enable bit, EMI bit will be cleared automatically. This will prevent any further interrupt nesting from occurring. However, if other interrupt requests occur during this interval, although the interrupt will not be immediately serviced, the request flag will still be recorded.

If an interrupt requires immediate servicing while the program is already in another interrupt service routine, the EMI bit should be set after entering the routine, to allow interrupt nesting. If the stack is full, the interrupt request will not be acknowledged, even if the related interrupt is enabled, until the Stack Pointer is decremented. If immediate service is desired, the stack must be prevented from becoming full. In case of simultaneous requests, the accompanying diagram shows the priority that is applied. All of the interrupt request flags when set will wake-up the device if it is in SLEEP or IDLE Mode, however to prevent a wake-up from occurring the corresponding flag should be set before the device is in SLEEP or IDLE Mode.

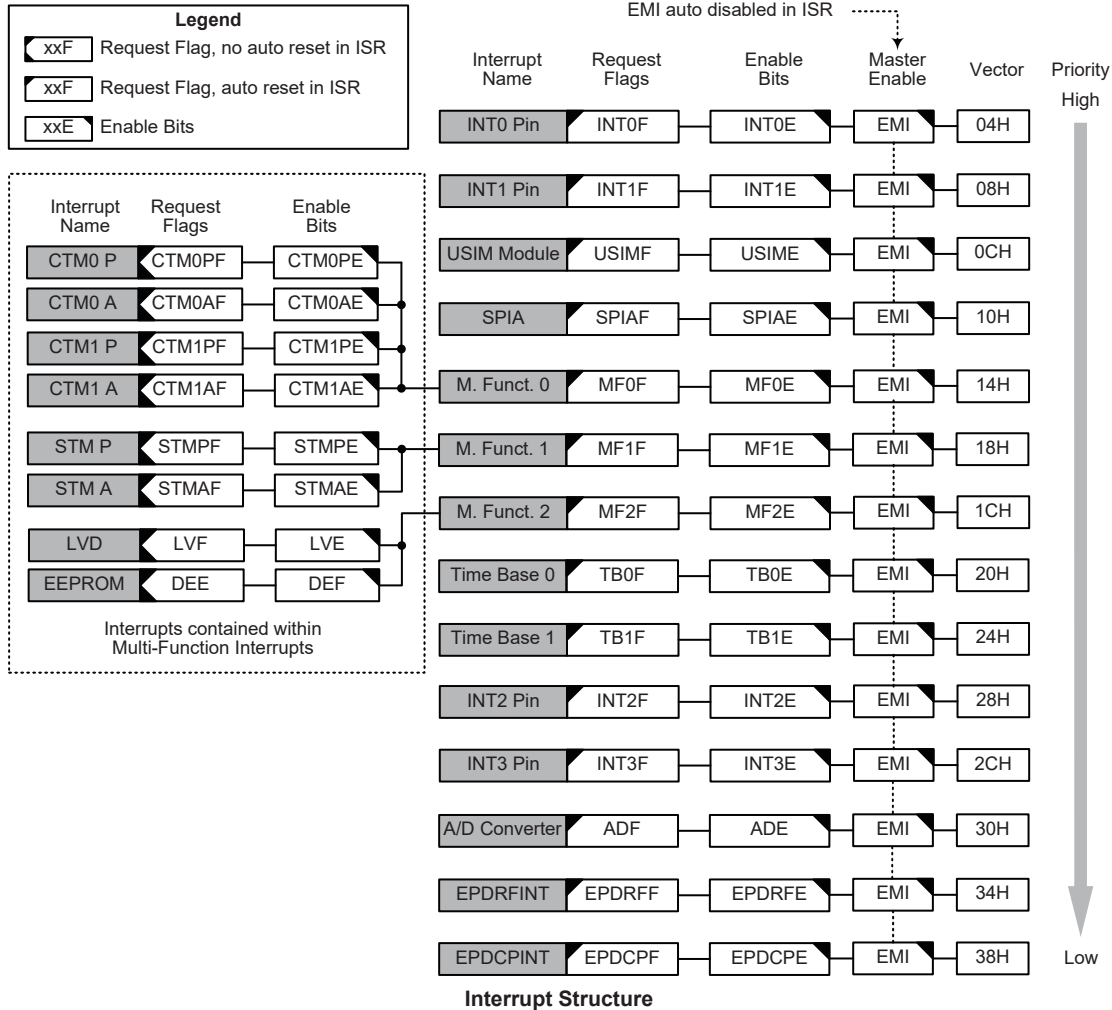

External Interrupt

The external interrupts are controlled by signal transitions on the pins INT0~INT3. An external interrupt request will take place when the external interrupt request flags, INT0F~INT3F, are set, which will occur when a transition, whose type is chosen by the edge select bits, appears on the external interrupt pins. To allow the program to branch to its respective interrupt vector address, the global interrupt enable bit, EMI, and respective external interrupt enable bit, INT0E~INT3E, must first be set. Additionally the correct interrupt edge type must be selected using the INTEG register to enable the external interrupt function and to choose the trigger edge type. As the external interrupt pins are pin-shared with I/O pins, they can only be configured as external interrupt pins if their external interrupt enable bit in the corresponding interrupt register has been set and the external interrupt pin is selected by the corresponding pin-shared function selection bits. The pin must also be setup as an input by setting the corresponding bit in the port control register.

When the interrupt is enabled, the stack is not full and the correct transition type appears on the external interrupt pin, a subroutine call to the external interrupt vector, will take place. When the interrupt is serviced, the external interrupt request flags, INT0F~INT3F, will be automatically reset and the EMI bit will be automatically cleared to disable other interrupts. Note that any pull-high resistor selections on the external interrupt pins will remain valid even if the pin is used as an

external interrupt input. The INTEG register is used to select the type of active edge that will trigger the external interrupt. A choice of either rising or falling or both edge types can be chosen to trigger an external interrupt. Note that the INTEG register can also be used to disable the external interrupt function.

Multi-function Interrupt

Within the device there are seven Multi-function interrupts. Unlike the other independent interrupts, these interrupts have no independent source, but rather are formed from other existing interrupt sources, namely the TM interrupts, LVD interrupt and EEPROM write operation interrupt.

A Multi-function interrupt request will take place when any of the Multi-function interrupt request flags MFnF are set. The Multi-function interrupt flags will be set when any of their included functions generate an interrupt request flag. To allow the program to branch to its respective interrupt vector address, when the Multi-function interrupt is enabled and the stack is not full, and either one of the interrupts contained within each of Multi-function interrupt occurs, a subroutine call to one of the Multi-function interrupt vectors will take place. When the interrupt is serviced, the related Multi-Function request flag will be automatically reset and the EMI bit will be automatically cleared to disable other interrupts.

However, it must be noted that, although the Multi-function Interrupt request flags will be automatically reset when the interrupt is serviced, the request flags from the original source of the Multi-function interrupts will not be automatically reset and must be manually reset by the application program.

Timer Module Interrupts

The Compact and Standard type TMs each has two interrupts, one comes from the comparator A match situation and the other comes from the comparator P match situation. All of the TM interrupts are contained within the Multi-function Interrupts. For all of the TM types there are two interrupt request flags and two enable control bits. A TM interrupt request will take place when any of the TM request flags are set, a situation which occurs when a TM comparator P or A match situation happens.

To allow the program to branch to its respective interrupt vector address, the global interrupt enable bit, EMI, respective TM Interrupt enable bit, and relevant Multi-function Interrupt enable bit, MFnE, must first be set. When the interrupt is enabled, the stack is not full and a TM comparator match situation occurs, a subroutine call to the relevant Multi-function Interrupt vector locations, will take place. When the TM interrupt is serviced, the EMI bit will be automatically cleared to disable other interrupts. However, only the related MFnF flag will be automatically cleared. As the TM interrupt request flags will not be automatically cleared, they have to be cleared by the application program.

LVD Interrupt

The Low Voltage Detector Interrupt is contained within the Multi-function Interrupt. A LVD Interrupt request will take place when the LVD Interrupt request flag, LVF, is set, which occurs when the Low Voltage Detector function detects a low power supply voltage. To allow the program to branch to its respective interrupt vector address, the global interrupt enable bit, EMI, Low Voltage Interrupt enable bit, LVE, and associated Multi-function interrupt enable bit, must first be set. When the interrupt is enabled, the stack is not full and a low voltage condition occurs, a subroutine call to the Multi-function Interrupt vector, will take place. When the Low Voltage Interrupt is serviced, the EMI bit will be automatically cleared to disable other interrupts, however only the Multi-function interrupt request flag will be also automatically cleared. As the LVF flag will not be automatically cleared, it has to be cleared by the application program.

EEPROM Interrupt

The EEPROM Interrupt is contained within the Multi-function Interrupt. An EEPROM Interrupt request will take place when the EEPROM Interrupt request flag, DEF, is set, which occurs when an EEPROM Write cycle ends. To allow the program to branch to its respective interrupt vector address, the global interrupt enable bit, EMI, and EEPROM Interrupt enable bit, DEE, and associated Multi-function interrupt enable bit, must first be set. When the interrupt is enabled, the stack is not full and an EEPROM Write cycle ends, a subroutine call to the respective EEPROM Interrupt vector will take place. When the EEPROM Interrupt is serviced, the EMI bit will be automatically cleared to disable other interrupts, however only the Multi-function interrupt request flag will be also automatically cleared. As the DEF flag will not be automatically cleared, it has to be cleared by the application program.

A/D Converter Interrupt

The A/D Converter Interrupt is controlled by the termination of an A/D conversion process. An A/D Converter Interrupt request will take place when the A/D Converter Interrupt request flag, ADF, is set, which occurs when the A/D conversion process finishes. To allow the program to branch to its respective interrupt vector address, the global interrupt enable bit, EMI, and A/D Converter Interrupt enable bit, ADE, must first be set. When the interrupt is enabled, the stack is not full and the A/D conversion process has ended, a subroutine call to the A/D Converter Interrupt vector, will take place. When the interrupt is serviced, the A/D Converter Interrupt flag, ADF, will be automatically cleared. The EMI bit will also be automatically cleared to disable other interrupts.

Universal Serial Interface Module Interrupt

The Universal Serial Interface Module Interrupt, also known as the USIM interrupt, will take place when the USIM Interrupt request flag, USIMF, is set. As the USIM interface can operate in three modes which are SPI mode, I²C mode and UART mode, the USIMF flag can be set by different conditions depending on the selected interface mode.

If the SPI or I²C mode is selected, the USIM interrupt can be triggered when a byte of data has been received or transmitted by the USIM SPI or I²C interface, or an I²C slave address match occurs, or an I²C bus time-out occurs. If the UART mode is selected, several individual UART conditions including a transmitter data register empty, transmitter idle, receiver data available, receiver overrun, address detect and an RX pin wake-up, can generate a USIM interrupt with the USIMF flag bit set high.

To allow the program to branch to its respective interrupt vector address, the global interrupt enable bit, EMI, and the Serial Interface Interrupt enable bit, USIME, must first be set. When the interrupt is enabled, the stack is not full and any of the above described situations occurs, a subroutine call to the respective Interrupt vector, will take place. When the interrupt is serviced, the Universal Serial Interface Interrupt flag, USIMF, will be automatically cleared. The EMI bit will also be automatically cleared to disable other interrupts.

Note that if the USIM interrupt is triggered by the UART interface, after the interrupt has been serviced, the UUSR register flags will only be cleared when certain actions are taken by the UART, the details of which are given in the UART section.

SPIA Interface Interrupt

An SPIA Interrupt request will take place when the SPIA Interrupt request flag, SPIAF, is set, which occurs when a byte of data has been received or transmitted by the SPIA interface. To allow the program to branch to its respective interrupt vector address, the global interrupt enable bit, EMI, and the Serial Interface Interrupt enable bit, SPIAE, must first be set. When the interrupt is enabled,

the stack is not full and a byte of data has been transmitted or received by the SPIA interface, a subroutine call to the respective Interrupt vector will take place. When the SPIA Interface Interrupt is serviced, the SPIAF flag will be automatically cleared, the EMI bit will also be automatically cleared to disable other interrupts.

EPD Charge Pump Voltage Ready Interrupt

An EPD Charge Pump Voltage Ready Interrupt request will take place when the EPD Charge Pump Voltage Ready Interrupt request flag, EPDCPF, is set. To allow the program to branch to its respective interrupt vector address, the global interrupt enable bit, EMI, and the EPD Charge Pump Voltage Ready Interrupt enable bit, EPDCPE, must first be set. When the interrupt is enabled, the stack is not full and the EPD Charge pump voltage stable, a subroutine call to the respective Interrupt vector will take place. When the EPD Charge Pump Voltage Ready Interrupt is serviced, the EPDCPF flag will be automatically cleared, the EMI bit will also be automatically cleared to disable other interrupts.

EPD Refresh Finished Interrupt

An EPD Refresh Finished Interrupt request will take place when the EPD refresh finished Interrupt request flag, EPDRFF, is set. To allow the program to branch to its respective interrupt vector address, the global interrupt enable bit, EMI, and the EPD Refresh Finished Interrupt enable bit, EPDRFE, must first be set. When the interrupt is enabled, the stack is not full and the EPD refresh finished, a subroutine call to the respective Interrupt vector, will take place. When the Refresh Finished Interrupt is serviced, the EPDRFF flag will be automatically cleared, the EMI bit will also be automatically cleared to disable other interrupts.

Time Base Interrupts

The function of the Time Base Interrupts is to provide regular time signal in the form of an internal interrupt. They are controlled by the overflow signals from their respective timer functions. When these happens their respective interrupt request flags, TB0F or TB1F will be set. To allow the program to branch to their respective interrupt vector addresses, the global interrupt enable bit, EMI, and Time Base enable bits, TB0E or TB1E, must first be set. When the interrupt is enabled, the stack is not full and the Time Base overflows, a subroutine call to their respective vector locations will take place. When the interrupt is serviced, the respective interrupt request flag, TB0F or TB1F, will be automatically cleared, the EMI bit will also be automatically cleared to disable other interrupts.

The purpose of the Time Base Interrupt is to provide an interrupt signal at fixed time periods. Its clock source, f_{PSC0} or f_{PSC1} , originates from the internal clock source $f_{LXT}/8$ and then passes through a divider, the division ratio of which is selected by programming the appropriate bits in the TB0C and TB1C registers to obtain longer interrupt periods whose value ranges.

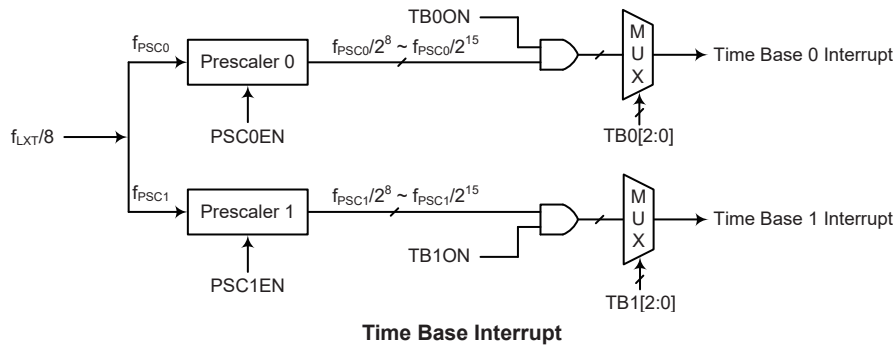

• PSCnR Register (n=0~1)

Bit	7	6	5	4	3	2	1	0
Name	—	—	—	—	—	—	—	PSCnEN
R/W	—	—	—	—	—	—	—	R/W
POR	—	—	—	—	—	—	—	0

Bit 7~1 Unimplemented, read as “0”

Bit 0 **PSCnEN**: Prescaler n clock enable control
0: Disable
1: Enable

This PSCnEN bit is the Prescaler n clock enable/disable control bit. When the Prescaler clock is disabled, it can reduce extra power consumption. Prescaler n clock is sourced from the LXT oscillator output frequency of $f_{LXT}/8$.

• TB0C Register

Bit	7	6	5	4	3	2	1	0
Name	TB0ON	—	—	—	—	TB02	TB01	TB00
R/W	R/W	—	—	—	—	R/W	R/W	R/W
POR	0	—	—	—	—	0	0	0

Bit 7 **TB0ON**: Time Base 0 Control
0: Disable
1: Enable

Bit 6~3 Unimplemented, read as “0”

Bit 2~0 **TB02~TB00**: Select Time Base 0 Time-out Period
000: $2^8/f_{PSC0}$
001: $2^9/f_{PSC0}$
010: $2^{10}/f_{PSC0}$
011: $2^{11}/f_{PSC0}$
100: $2^{12}/f_{PSC0}$
101: $2^{13}/f_{PSC0}$
110: $2^{14}/f_{PSC0}$
111: $2^{15}/f_{PSC0}$

• TB1C Register

Bit	7	6	5	4	3	2	1	0
Name	TB1ON	—	—	—	—	TB12	TB11	TB10
R/W	R/W	—	—	—	—	R/W	R/W	R/W
POR	0	—	—	—	—	0	0	0

Bit 7 **TB1ON**: Time Base 1 Control
0: Disable
1: Enable

Bit 6~3 Unimplemented, read as “0”

Bit 2~0 **TB12~TB10**: Select Time Base 1 Time-out Period
000: $2^8/f_{PSC1}$
001: $2^9/f_{PSC1}$
010: $2^{10}/f_{PSC1}$
011: $2^{11}/f_{PSC1}$
100: $2^{12}/f_{PSC1}$
101: $2^{13}/f_{PSC1}$
110: $2^{14}/f_{PSC1}$
111: $2^{15}/f_{PSC1}$

Interrupt Wake-up Function

Each of the interrupt functions has the capability of waking up the microcontroller when in the SLEEP or IDLE Mode. A wake-up is generated when an interrupt request flag changes from low to high and is independent of whether the interrupt is enabled or not. Therefore, even though the device is in the SLEEP or IDLE Mode and its system oscillator stopped, situations such as external edge transitions on the external interrupt pins or a low power supply voltage may cause their respective interrupt flag to be set high and consequently generate an interrupt. Care must therefore be taken if spurious wake-up situations are to be avoided. If an interrupt wake-up function is to be disabled then the corresponding interrupt request flag should be set high before the device enters the SLEEP or IDLE Mode. The interrupt enable bits have no effect on the interrupt wake-up function.

Programming Considerations

By disabling the relevant interrupt enable bits, a requested interrupt can be prevented from being serviced, however, once an interrupt request flag is set, it will remain in this condition in the interrupt register until the corresponding interrupt is serviced or until the request flag is cleared by the application program.

Where a certain interrupt is contained within a Multi-function interrupt, then when the interrupt service routine is executed, as only the Multi-function interrupt request flags, MF_nF, will be automatically cleared, the individual request flag for the function needs to be cleared by the application program.

It is recommended that programs do not use the “CALL” instruction within the interrupt service subroutine. Interrupts often occur in an unpredictable manner or need to be serviced immediately. If only one stack is left and the interrupt is not well controlled, the original control sequence will be damaged once a CALL subroutine is executed in the interrupt subroutine.

Every interrupt has the capability of waking up the microcontroller when it is in SLEEP or IDLE Mode, the wake up being generated when the interrupt request flag changes from low to high. If it is required to prevent a certain interrupt from waking up the microcontroller then its respective request flag should be first set high before enter SLEEP or IDLE Mode.

As only the Program Counter is pushed onto the stack, then when the interrupt is serviced, if the contents of the accumulator, status register or other registers are altered by the interrupt service program, their contents should be saved to the memory at the beginning of the interrupt service routine. To return from an interrupt subroutine, either a RET or RETI instruction may be executed. The RETI instruction in addition to executing a return to the main program also automatically sets the EMI bit high to allow further interrupts. The RET instruction however only executes a return to the main program leaving the EMI bit in its present zero state and therefore disabling the execution of further interrupts.

Low Voltage Detector – LVD

The device has a Low Voltage Detector function, also known as LVD. This enabled the device to monitor the power supply voltage, V_{DD} , and provide a warning signal should it fall below a certain level. This function may be especially useful in battery applications where the supply voltage will gradually reduce as the battery ages, as it allows an early warning battery low signal to be generated. The Low Voltage Detector also has the capability of generating an interrupt signal.

LVD Register

The Low Voltage Detector function is controlled using a single register with the name LVDC. Four bits in this register, VLVD3~VLVD0, are used to select one of sixteen fixed voltages below which a low voltage condition will be determined. A low voltage condition is indicated when the LVDO bit is set. If the LVDO bit is low, this indicates that the V_{DD} voltage is above the preset low voltage value. The LVDEN bit is used to control the overall on/off function of the low voltage detector. Setting the bit high will enable the low voltage detector. Clearing the bit to zero will switch off the internal low voltage detector circuits. As the low voltage detector will consume a certain amount of power, it may be desirable to switch off the circuit when not in use, an important consideration in power sensitive battery powered applications.

• LVDC Register

Bit	7	6	5	4	3	2	1	0
Name	—	—	LVDO	LVDEN	VLVD3	VLVD2	VLVD1	VLVD0
R/W	—	—	R	R/W	R/W	R/W	R/W	R/W
POR	—	—	0	0	0	0	0	0

Bit 7~6 Unimplemented, read as “0”

Bit 5 **LVDO**: LVD Output Flag
 0: No Low Voltage Detect
 1: Low Voltage Detect

Bit 4 **LVDEN**: Low Voltage Detector Control
 0: Disable
 1: Enable

Bit 3~0 **VLVD3~VLVD0**: Select LVD Voltage
 0000: 1.8V
 0001: 1.9V
 0010: 2.0V
 0011: 2.1V
 0100: 2.2V
 0101: 2.3V
 0110: 2.4V
 0111: 2.5V
 1000: 2.6V
 1001: 2.7V
 1010: 2.8V
 1011: 2.9V
 1100: 3.0V
 1101: 3.3V
 1110: 3.6V
 1111: 4.0V

LVD Operation

The Low Voltage Detector function operates by comparing the power supply voltage, V_{DD} , with a pre-specified voltage level stored in the LVDC register. This has a range of between 1.8V and 4.0V. When the power supply voltage, V_{DD} , falls below this pre-determined value, the LVDO bit will be set high indicating a low power supply voltage condition. When the device is in the SLEEP mode, the low voltage detector will be disabled even if the LVDEN bit is high. After enabling the Low Voltage Detector, a time delay t_{LVDS} should be allowed for the circuitry to stabilise before reading the LVDO bit. Note also that as the V_{DD} voltage may rise and fall rather slowly, at the voltage nears that of V_{LVD} , there may be multiple bit LVDO transitions.

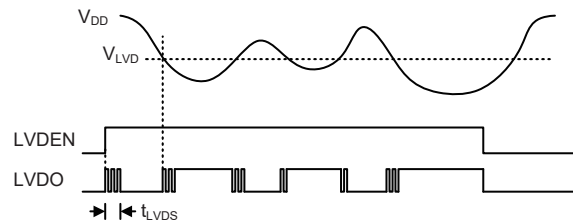

LVD Operation

The Low Voltage Detector has its own interrupt which is contained within one of the Multi-function interrupts, providing an alternative means of low voltage detection, in addition to polling the LVDO bit. The interrupt will only be generated after a delay of t_{LVD} after the LVDO bit has been set high by a low voltage condition. When the device is in the SLEEP mode, the low voltage detector will be disabled even if the LVDEN bit is high. In this case, the LVF interrupt request flag will be set, causing an interrupt to be generated if V_{DD} falls below the preset LVD voltage. This will cause the device to wake-up from the IDLE Mode, however if the Low Voltage Detector wake up function is not required then the LVF flag should be first set high before the device enters the IDLE Mode.

Configuration Options

Configuration options refer to certain options within the MCU that are programmed into the device during the programming process. During the development process, these options are selected using the HT-IDE software development tools. All options must be defined for proper system function, the details of which are shown in the table.

No.	Options
Oscillator Option	
1	HIRC frequency selection: f_{HIRC} – 4MHz, 8MHz or 12MHz

Note: When the HIRC has been configured at a frequency shown in this table, the HIRC1 and HIRC0 bits should also be setup to select the same frequency to achieve the HIRC frequency accuracy specified in the A.C. Characteristics.

Application Circuits

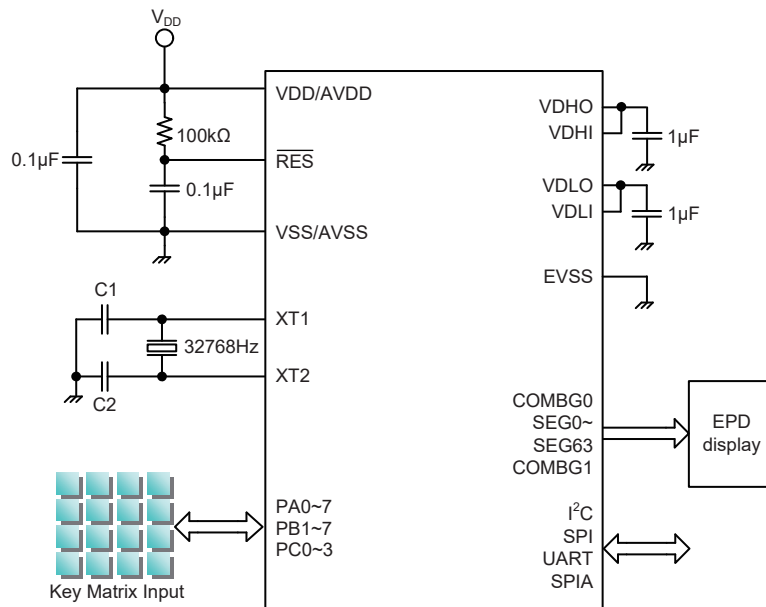

Note: VDHO and VDLO pins boost capacitor can be sized by electronic paper size.

Instruction Set

Introduction

Central to the successful operation of any microcontroller is its instruction set, which is a set of program instruction codes that directs the microcontroller to perform certain operations. In the case of Holtek microcontroller, a comprehensive and flexible set of over 60 instructions is provided to enable programmers to implement their application with the minimum of programming overheads.

For easier understanding of the various instruction codes, they have been subdivided into several functional groupings.

Instruction Timing

Most instructions are implemented within one instruction cycle. The exceptions to this are branch, call, or table read instructions where two instruction cycles are required. One instruction cycle is equal to 4 system clock cycles, therefore in the case of an 8MHz system oscillator, most instructions would be implemented within 0.5 μ s and branch or call instructions would be implemented within 1 μ s. Although instructions which require one more cycle to implement are generally limited to the JMP, CALL, RET, RETI and table read instructions, it is important to realize that any other instructions which involve manipulation of the Program Counter Low register or PCL will also take one more cycle to implement. As instructions which change the contents of the PCL will imply a direct jump to that new address, one more cycle will be required. Examples of such instructions would be “CLR PCL” or “MOV PCL, A”. For the case of skip instructions, it must be noted that if the result of the comparison involves a skip operation then this will also take one more cycle, if no skip is involved then only one cycle is required.

Moving and Transferring Data

The transfer of data within the microcontroller program is one of the most frequently used operations. Making use of several kinds of MOV instructions, data can be transferred from registers to the Accumulator and vice-versa as well as being able to move specific immediate data directly into the Accumulator. One of the most important data transfer applications is to receive data from the input ports and transfer data to the output ports.

Arithmetic Operations

The ability to perform certain arithmetic operations and data manipulation is a necessary feature of most microcontroller applications. Within the Holtek microcontroller instruction set are a range of add and subtract instruction mnemonics to enable the necessary arithmetic to be carried out. Care must be taken to ensure correct handling of carry and borrow data when results exceed 255 for addition and less than 0 for subtraction. The increment and decrement instructions such as INC, INCA, DEC and DECA provide a simple means of increasing or decreasing by a value of one of the values in the destination specified.

Logical and Rotate Operation

The standard logical operations such as AND, OR, XOR and CPL all have their own instruction within the Holtek microcontroller instruction set. As with the case of most instructions involving data manipulation, data must pass through the Accumulator which may involve additional programming steps. In all logical data operations, the zero flag may be set if the result of the operation is zero. Another form of logical data manipulation comes from the rotate instructions such as RR, RL, RRC and RLC which provide a simple means of rotating one bit right or left. Different rotate instructions exist depending on program requirements. Rotate instructions are useful for serial port programming applications where data can be rotated from an internal register into the Carry bit from where it can be examined and the necessary serial bit set high or low. Another application which rotate data operations are used is to implement multiplication and division calculations.

Branches and Control Transfer

Program branching takes the form of either jumps to specified locations using the JMP instruction or to a subroutine using the CALL instruction. They differ in the sense that in the case of a subroutine call, the program must return to the instruction immediately when the subroutine has been carried out. This is done by placing a return instruction “RET” in the subroutine which will cause the program to jump back to the address right after the CALL instruction. In the case of a JMP instruction, the program simply jumps to the desired location. There is no requirement to jump back to the original jumping off point as in the case of the CALL instruction. One special and extremely useful set of branch instructions are the conditional branches. Here a decision is first made regarding the condition of a certain data memory or individual bits. Depending upon the conditions, the program will continue with the next instruction or skip over it and jump to the following instruction. These instructions are the key to decision making and branching within the program perhaps determined by the condition of certain input switches or by the condition of internal data bits.

Bit Operations

The ability to provide single bit operations on Data Memory is an extremely flexible feature of all Holtek microcontrollers. This feature is especially useful for output port bit programming where individual bits or port pins can be directly set high or low using either the “SET [m].i” or “CLR [m].i” instructions respectively. The feature removes the need for programmers to first read the 8-bit output port, manipulate the input data to ensure that other bits are not changed and then output the port with the correct new data. This read-modify-write process is taken care of automatically when these bit operation instructions are used.

Table Read Operations

Data storage is normally implemented by using registers. However, when working with large amounts of fixed data, the volume involved often makes it inconvenient to store the fixed data in the Data Memory. To overcome this problem, Holtek microcontrollers allow an area of Program Memory to be setup as a table where data can be directly stored. A set of easy to use instructions provides the means by which this fixed data can be referenced and retrieved from the Program Memory.

Other Operations

In addition to the above functional instructions, a range of other instructions also exist such as the “HALT” instruction for Power-down operations and instructions to control the operation of the Watchdog Timer for reliable program operations under extreme electric or electromagnetic environments. For their relevant operations, refer to the functional related sections.

Instruction Set Summary

The instructions related to the data memory access in the following table can be used when the desired data memory is located in Data Memory sector 0.

Table Conventions

x: Bits immediate data
 m: Data Memory address
 A: Accumulator
 i: 0~7 number of bits
 addr: Program memory address

Mnemonic	Description	Cycles	Flag Affected
Arithmetic			
ADD A,[m]	Add Data Memory to ACC	1	Z, C, AC, OV, SC
ADDM A,[m]	Add ACC to Data Memory	1 ^{Note}	Z, C, AC, OV, SC
ADD A,x	Add immediate data to ACC	1	Z, C, AC, OV, SC
ADC A,[m]	Add Data Memory to ACC with Carry	1	Z, C, AC, OV, SC
ADCM A,[m]	Add ACC to Data memory with Carry	1 ^{Note}	Z, C, AC, OV, SC
SUB A,x	Subtract immediate data from the ACC	1	Z, C, AC, OV, SC, CZ
SUB A,[m]	Subtract Data Memory from ACC	1	Z, C, AC, OV, SC, CZ
SUBM A,[m]	Subtract Data Memory from ACC with result in Data Memory	1 ^{Note}	Z, C, AC, OV, SC, CZ
SBC A,x	Subtract immediate data from ACC with Carry	1	Z, C, AC, OV, SC, CZ
SBC A,[m]	Subtract Data Memory from ACC with Carry	1	Z, C, AC, OV, SC, CZ
SBCM A,[m]	Subtract Data Memory from ACC with Carry, result in Data Memory	1 ^{Note}	Z, C, AC, OV, SC, CZ
DAA [m]	Decimal adjust ACC for Addition with result in Data Memory	1 ^{Note}	C
Logic Operation			
AND A,[m]	Logical AND Data Memory to ACC	1	Z
OR A,[m]	Logical OR Data Memory to ACC	1	Z
XOR A,[m]	Logical XOR Data Memory to ACC	1	Z
ANDM A,[m]	Logical AND ACC to Data Memory	1 ^{Note}	Z
ORM A,[m]	Logical OR ACC to Data Memory	1 ^{Note}	Z
XORM A,[m]	Logical XOR ACC to Data Memory	1 ^{Note}	Z
AND A,x	Logical AND immediate Data to ACC	1	Z
OR A,x	Logical OR immediate Data to ACC	1	Z
XOR A,x	Logical XOR immediate Data to ACC	1	Z
CPL [m]	Complement Data Memory	1 ^{Note}	Z
CPLA [m]	Complement Data Memory with result in ACC	1	Z
Increment & Decrement			
INCA [m]	Increment Data Memory with result in ACC	1	Z
INC [m]	Increment Data Memory	1 ^{Note}	Z
DECA [m]	Decrement Data Memory with result in ACC	1	Z
DEC [m]	Decrement Data Memory	1 ^{Note}	Z
Rotate			
RRA [m]	Rotate Data Memory right with result in ACC	1	None
RR [m]	Rotate Data Memory right	1 ^{Note}	None
RRCA [m]	Rotate Data Memory right through Carry with result in ACC	1	C
RRC [m]	Rotate Data Memory right through Carry	1 ^{Note}	C
RLA [m]	Rotate Data Memory left with result in ACC	1	None
RL [m]	Rotate Data Memory left	1 ^{Note}	None
RLCA [m]	Rotate Data Memory left through Carry with result in ACC	1	C
RLC [m]	Rotate Data Memory left through Carry	1 ^{Note}	C

Mnemonic	Description	Cycles	Flag Affected
Data Move			
MOV A,[m]	Move Data Memory to ACC	1	None
MOV [m],A	Move ACC to Data Memory	1 ^{Note}	None
MOV A,x	Move immediate data to ACC	1	None
Bit Operation			
CLR [m].i	Clear bit of Data Memory	1 ^{Note}	None
SET [m].i	Set bit of Data Memory	1 ^{Note}	None
Branch Operation			
JMP addr	Jump unconditionally	2	None
SZ [m]	Skip if Data Memory is zero	1 ^{Note}	None
SZA [m]	Skip if Data Memory is zero with data movement to ACC	1 ^{Note}	None
SZ [m].i	Skip if bit i of Data Memory is zero	1 ^{Note}	None
SNZ [m]	Skip if Data Memory is not zero	1 ^{Note}	None
SNZ [m].i	Skip if bit i of Data Memory is not zero	1 ^{Note}	None
SIZ [m]	Skip if increment Data Memory is zero	1 ^{Note}	None
SDZ [m]	Skip if decrement Data Memory is zero	1 ^{Note}	None
SIZA [m]	Skip if increment Data Memory is zero with result in ACC	1 ^{Note}	None
SDZA [m]	Skip if decrement Data Memory is zero with result in ACC	1 ^{Note}	None
CALL addr	Subroutine call	2	None
RET	Return from subroutine	2	None
RET A,x	Return from subroutine and load immediate data to ACC	2	None
RETI	Return from interrupt	2	None
Table Read Operation			
TABRD [m]	Read table (specific page) to TBLH and Data Memory	2 ^{Note}	None
TABRDL [m]	Read table (last page) to TBLH and Data Memory	2 ^{Note}	None
ITABRD [m]	Increment table pointer TBLP first and Read table to TBLH and Data Memory	2 ^{Note}	None
ITABRDL [m]	Increment table pointer TBLP first and Read table (last page) to TBLH and Data Memory	2 ^{Note}	None
Miscellaneous			
NOP	No operation	1	None
CLR [m]	Clear Data Memory	1 ^{Note}	None
SET [m]	Set Data Memory	1 ^{Note}	None
CLR WDT	Clear Watchdog Timer	1	TO, PDF
SWAP [m]	Swap nibbles of Data Memory	1 ^{Note}	None
SWAPA [m]	Swap nibbles of Data Memory with result in ACC	1	None
HALT	Enter power down mode	1	TO, PDF

Note: 1. For skip instructions, if the result of the comparison involves a skip then up to three cycles are required, if no skip takes place only one cycle is required.

- Any instruction which changes the contents of the PCL will also require 2 cycles for execution.
- For the “CLR WDT” instruction the TO and PDF flags may be affected by the execution status. The TO and PDF flags are cleared after the “CLR WDT” instructions is executed. Otherwise the TO and PDF flags remain unchanged.

Extended Instruction Set

The extended instructions are used to support the full range address access for the data memory. When the accessed data memory is located in any data memory sections except sector 0, the extended instruction can be used to access the data memory instead of using the indirect addressing access to improve the CPU firmware performance.

Mnemonic	Description	Cycles	Flag Affected
Arithmetic			
LADD A,[m]	Add Data Memory to ACC	2	Z, C, AC, OV, SC
LADDM A,[m]	Add ACC to Data Memory	2 ^{Note}	Z, C, AC, OV, SC
LADC A,[m]	Add Data Memory to ACC with Carry	2	Z, C, AC, OV, SC
LADCM A,[m]	Add ACC to Data memory with Carry	2 ^{Note}	Z, C, AC, OV, SC
LSUB A,[m]	Subtract Data Memory from ACC	2	Z, C, AC, OV, SC, CZ
LSUBM A,[m]	Subtract Data Memory from ACC with result in Data Memory	2 ^{Note}	Z, C, AC, OV, SC, CZ
LSBC A,[m]	Subtract Data Memory from ACC with Carry	2	Z, C, AC, OV, SC, CZ
LSBCM A,[m]	Subtract Data Memory from ACC with Carry, result in Data Memory	2 ^{Note}	Z, C, AC, OV, SC, CZ
LDAA [m]	Decimal adjust ACC for Addition with result in Data Memory	2 ^{Note}	C
Logic Operation			
LAND A,[m]	Logical AND Data Memory to ACC	2	Z
LOR A,[m]	Logical OR Data Memory to ACC	2	Z
LXOR A,[m]	Logical XOR Data Memory to ACC	2	Z
LANDM A,[m]	Logical AND ACC to Data Memory	2 ^{Note}	Z
LORM A,[m]	Logical OR ACC to Data Memory	2 ^{Note}	Z
LXORM A,[m]	Logical XOR ACC to Data Memory	2 ^{Note}	Z
LCPL [m]	Complement Data Memory	2 ^{Note}	Z
LCPLA [m]	Complement Data Memory with result in ACC	2	Z
Increment & Decrement			
LINCA [m]	Increment Data Memory with result in ACC	2	Z
LINC [m]	Increment Data Memory	2 ^{Note}	Z
LDECA [m]	Decrement Data Memory with result in ACC	2	Z
LDEC [m]	Decrement Data Memory	2 ^{Note}	Z
Rotate			
LRR A,[m]	Rotate Data Memory right with result in ACC	2	None
LRR [m]	Rotate Data Memory right	2 ^{Note}	None
LRRCA [m]	Rotate Data Memory right through Carry with result in ACC	2	C
LRRC [m]	Rotate Data Memory right through Carry	2 ^{Note}	C
LRL A,[m]	Rotate Data Memory left with result in ACC	2	None
LRL [m]	Rotate Data Memory left	2 ^{Note}	None
LRLCA [m]	Rotate Data Memory left through Carry with result in ACC	2	C
LRLC [m]	Rotate Data Memory left through Carry	2 ^{Note}	C
Data Move			
LMOV A,[m]	Move Data Memory to ACC	2	None
LMOV [m],A	Move ACC to Data Memory	2 ^{Note}	None
Bit Operation			
LCLR [m].i	Clear bit of Data Memory	2 ^{Note}	None
LSET [m].i	Set bit of Data Memory	2 ^{Note}	None

Mnemonic	Description	Cycles	Flag Affected
Branch			
LSZ [m]	Skip if Data Memory is zero	2 ^{Note}	None
LSZA [m]	Skip if Data Memory is zero with data movement to ACC	2 ^{Note}	None
LSNZ [m]	Skip if Data Memory is not zero	2 ^{Note}	None
LSZ [m].i	Skip if bit i of Data Memory is zero	2 ^{Note}	None
LSNZ [m].i	Skip if bit i of Data Memory is not zero	2 ^{Note}	None
LSIZ [m]	Skip if increment Data Memory is zero	2 ^{Note}	None
LSDZ [m]	Skip if decrement Data Memory is zero	2 ^{Note}	None
LSIZA [m]	Skip if increment Data Memory is zero with result in ACC	2 ^{Note}	None
LSDZA [m]	Skip if decrement Data Memory is zero with result in ACC	2 ^{Note}	None
Table Read			
LTABRD [m]	Read table to TBLH and Data Memory	3 ^{Note}	None
LTABRDL [m]	Read table (last page) to TBLH and Data Memory	3 ^{Note}	None
LITABRD [m]	Increment table pointer TBLP first and Read table to TBLH and Data Memory	3 ^{Note}	None
LITABRDL [m]	Increment table pointer TBLP first and Read table (last page) to TBLH and Data Memory	3 ^{Note}	None
Miscellaneous			
LCLR [m]	Clear Data Memory	2 ^{Note}	None
LSET [m]	Set Data Memory	2 ^{Note}	None
LSWAP [m]	Swap nibbles of Data Memory	2 ^{Note}	None
LSWAPA [m]	Swap nibbles of Data Memory with result in ACC	2	None

Note: 1. For these extended skip instructions, if the result of the comparison involves a skip then up to four cycles are required, if no skip takes place two cycles is required.

- Any extended instruction which changes the contents of the PCL register will also require three cycles for execution.

Instruction Definition

ADC A,[m]	Add Data Memory to ACC with Carry
Description	The contents of the specified Data Memory, Accumulator and the carry flag are added. The result is stored in the Accumulator.
Operation	$ACC \leftarrow ACC + [m] + C$
Affected flag(s)	OV, Z, AC, C, SC
ADCM A,[m]	Add ACC to Data Memory with Carry
Description	The contents of the specified Data Memory, Accumulator and the carry flag are added. The result is stored in the specified Data Memory.
Operation	$[m] \leftarrow ACC + [m] + C$
Affected flag(s)	OV, Z, AC, C, SC
ADD A,[m]	Add Data Memory to ACC
Description	The contents of the specified Data Memory and the Accumulator are added. The result is stored in the Accumulator.
Operation	$ACC \leftarrow ACC + [m]$
Affected flag(s)	OV, Z, AC, C, SC
ADD A,x	Add immediate data to ACC
Description	The contents of the Accumulator and the specified immediate data are added. The result is stored in the Accumulator.
Operation	$ACC \leftarrow ACC + x$
Affected flag(s)	OV, Z, AC, C, SC
ADDM A,[m]	Add ACC to Data Memory
Description	The contents of the specified Data Memory and the Accumulator are added. The result is stored in the specified Data Memory.
Operation	$[m] \leftarrow ACC + [m]$
Affected flag(s)	OV, Z, AC, C, SC
AND A,[m]	Logical AND Data Memory to ACC
Description	Data in the Accumulator and the specified Data Memory perform a bitwise logical AND operation. The result is stored in the Accumulator.
Operation	$ACC \leftarrow ACC \text{ "AND" } [m]$
Affected flag(s)	Z
AND A,x	Logical AND immediate data to ACC
Description	Data in the Accumulator and the specified immediate data perform a bit wise logical AND operation. The result is stored in the Accumulator.
Operation	$ACC \leftarrow ACC \text{ "AND" } x$
Affected flag(s)	Z
ANDM A,[m]	Logical AND ACC to Data Memory
Description	Data in the specified Data Memory and the Accumulator perform a bitwise logical AND operation. The result is stored in the Data Memory.
Operation	$[m] \leftarrow ACC \text{ "AND" } [m]$
Affected flag(s)	Z

CALL addr	Subroutine call
Description	Unconditionally calls a subroutine at the specified address. The Program Counter then increments by 1 to obtain the address of the next instruction which is then pushed onto the stack. The specified address is then loaded and the program continues execution from this new address. As this instruction requires an additional operation, it is a two cycle instruction.
Operation	Stack \leftarrow Program Counter + 1 Program Counter \leftarrow addr
Affected flag(s)	None
CLR [m]	Clear Data Memory
Description	Each bit of the specified Data Memory is cleared to 0.
Operation	[m] \leftarrow 00H
Affected flag(s)	None
CLR [m].i	Clear bit of Data Memory
Description	Bit i of the specified Data Memory is cleared to 0.
Operation	[m].i \leftarrow 0
Affected flag(s)	None
CLR WDT	Clear Watchdog Timer
Description	The TO, PDF flags and the WDT are all cleared.
Operation	WDT cleared TO \leftarrow 0 PDF \leftarrow 0
Affected flag(s)	TO, PDF
CPL [m]	Complement Data Memory
Description	Each bit of the specified Data Memory is logically complemented (1's complement). Bits which previously contained a 1 are changed to 0 and vice versa.
Operation	[m] \leftarrow $\overline{[m]}$
Affected flag(s)	Z
CPLA [m]	Complement Data Memory with result in ACC
Description	Each bit of the specified Data Memory is logically complemented (1's complement). Bits which previously contained a 1 are changed to 0 and vice versa. The complemented result is stored in the Accumulator and the contents of the Data Memory remain unchanged.
Operation	ACC \leftarrow $\overline{[m]}$
Affected flag(s)	Z
DAA [m]	Decimal-Adjust ACC for addition with result in Data Memory
Description	Convert the contents of the Accumulator value to a BCD (Binary Coded Decimal) value resulting from the previous addition of two BCD variables. If the low nibble is greater than 9 or if AC flag is set, then a value of 6 will be added to the low nibble. Otherwise the low nibble remains unchanged. If the high nibble is greater than 9 or if the C flag is set, then a value of 6 will be added to the high nibble. Essentially, the decimal conversion is performed by adding 00H, 06H, 60H or 66H depending on the Accumulator and flag conditions. Only the C flag may be affected by this instruction which indicates that if the original BCD sum is greater than 100, it allows multiple precision decimal addition.
Operation	[m] \leftarrow ACC + 00H or [m] \leftarrow ACC + 06H or [m] \leftarrow ACC + 60H or [m] \leftarrow ACC + 66H
Affected flag(s)	C

DEC [m]	Decrement Data Memory
Description	Data in the specified Data Memory is decremented by 1.
Operation	$[m] \leftarrow [m] - 1$
Affected flag(s)	Z
DECA [m]	Decrement Data Memory with result in ACC
Description	Data in the specified Data Memory is decremented by 1. The result is stored in the Accumulator. The contents of the Data Memory remain unchanged.
Operation	$ACC \leftarrow [m] - 1$
Affected flag(s)	Z
HALT	Enter power down mode
Description	This instruction stops the program execution and turns off the system clock. The contents of the Data Memory and registers are retained. The WDT and prescaler are cleared. The power down flag PDF is set and the WDT time-out flag TO is cleared.
Operation	$TO \leftarrow 0$ $PDF \leftarrow 1$
Affected flag(s)	TO, PDF
INC [m]	Increment Data Memory
Description	Data in the specified Data Memory is incremented by 1.
Operation	$[m] \leftarrow [m] + 1$
Affected flag(s)	Z
INCA [m]	Increment Data Memory with result in ACC
Description	Data in the specified Data Memory is incremented by 1. The result is stored in the Accumulator. The contents of the Data Memory remain unchanged.
Operation	$ACC \leftarrow [m] + 1$
Affected flag(s)	Z
JMP addr	Jump unconditionally
Description	The contents of the Program Counter are replaced with the specified address. Program execution then continues from this new address. As this requires the insertion of a dummy instruction while the new address is loaded, it is a two cycle instruction.
Operation	Program Counter \leftarrow addr
Affected flag(s)	None
MOV A,[m]	Move Data Memory to ACC
Description	The contents of the specified Data Memory are copied to the Accumulator.
Operation	$ACC \leftarrow [m]$
Affected flag(s)	None
MOV A,x	Move immediate data to ACC
Description	The immediate data specified is loaded into the Accumulator.
Operation	$ACC \leftarrow x$
Affected flag(s)	None
MOV [m],A	Move ACC to Data Memory
Description	The contents of the Accumulator are copied to the specified Data Memory.
Operation	$[m] \leftarrow ACC$
Affected flag(s)	None

NOP	No operation
Description	No operation is performed. Execution continues with the next instruction.
Operation	No operation
Affected flag(s)	None
OR A,[m]	Logical OR Data Memory to ACC
Description	Data in the Accumulator and the specified Data Memory perform a bitwise logical OR operation. The result is stored in the Accumulator.
Operation	ACC ← ACC "OR" [m]
Affected flag(s)	Z
OR A,x	Logical OR immediate data to ACC
Description	Data in the Accumulator and the specified immediate data perform a bitwise logical OR operation. The result is stored in the Accumulator.
Operation	ACC ← ACC "OR" x
Affected flag(s)	Z
ORM A,[m]	Logical OR ACC to Data Memory
Description	Data in the specified Data Memory and the Accumulator perform a bitwise logical OR operation. The result is stored in the Data Memory.
Operation	[m] ← ACC "OR" [m]
Affected flag(s)	Z
RET	Return from subroutine
Description	The Program Counter is restored from the stack. Program execution continues at the restored address.
Operation	Program Counter ← Stack
Affected flag(s)	None
RET A,x	Return from subroutine and load immediate data to ACC
Description	The Program Counter is restored from the stack and the Accumulator loaded with the specified immediate data. Program execution continues at the restored address.
Operation	Program Counter ← Stack ACC ← x
Affected flag(s)	None
RETI	Return from interrupt
Description	The Program Counter is restored from the stack and the interrupts are re-enabled by setting the EMI bit. EMI is the master interrupt global enable bit. If an interrupt was pending when the RETI instruction is executed, the pending Interrupt routine will be processed before returning to the main program.
Operation	Program Counter ← Stack EMI ← 1
Affected flag(s)	None
RL [m]	Rotate Data Memory left
Description	The contents of the specified Data Memory are rotated left by 1 bit with bit 7 rotated into bit 0.
Operation	[m].(i+1) ← [m].i; (i=0~6) [m].0 ← [m].7
Affected flag(s)	None

RLA [m]	Rotate Data Memory left with result in ACC
Description	The contents of the specified Data Memory are rotated left by 1 bit with bit 7 rotated into bit 0. The rotated result is stored in the Accumulator and the contents of the Data Memory remain unchanged.
Operation	ACC.(i+1) ← [m].i; (i=0~6) ACC.0 ← [m].7
Affected flag(s)	None
RLC [m]	Rotate Data Memory left through Carry
Description	The contents of the specified Data Memory and the carry flag are rotated left by 1 bit. Bit 7 replaces the Carry bit and the original carry flag is rotated into bit 0.
Operation	[m].(i+1) ← [m].i; (i=0~6) [m].0 ← C C ← [m].7
Affected flag(s)	C
RLCA [m]	Rotate Data Memory left through Carry with result in ACC
Description	Data in the specified Data Memory and the carry flag are rotated left by 1 bit. Bit 7 replaces the Carry bit and the original carry flag is rotated into the bit 0. The rotated result is stored in the Accumulator and the contents of the Data Memory remain unchanged.
Operation	ACC.(i+1) ← [m].i; (i=0~6) ACC.0 ← C C ← [m].7
Affected flag(s)	C
RR [m]	Rotate Data Memory right
Description	The contents of the specified Data Memory are rotated right by 1 bit with bit 0 rotated into bit 7.
Operation	[m].i ← [m].(i+1); (i=0~6) [m].7 ← [m].0
Affected flag(s)	None
RRA [m]	Rotate Data Memory right with result in ACC
Description	Data in the specified Data Memory is rotated right by 1 bit with bit 0 rotated into bit 7. The rotated result is stored in the Accumulator and the contents of the Data Memory remain unchanged.
Operation	ACC.i ← [m].(i+1); (i=0~6) ACC.7 ← [m].0
Affected flag(s)	None
RRC [m]	Rotate Data Memory right through Carry
Description	The contents of the specified Data Memory and the carry flag are rotated right by 1 bit. Bit 0 replaces the Carry bit and the original carry flag is rotated into bit 7.
Operation	[m].i ← [m].(i+1); (i=0~6) [m].7 ← C C ← [m].0
Affected flag(s)	C

RRCA [m]	Rotate Data Memory right through Carry with result in ACC
Description	Data in the specified Data Memory and the carry flag are rotated right by 1 bit. Bit 0 replaces the Carry bit and the original carry flag is rotated into bit 7. The rotated result is stored in the Accumulator and the contents of the Data Memory remain unchanged.
Operation	ACC.i ← [m].(i+1); (i=0~6) ACC.7 ← C C ← [m].0
Affected flag(s)	C
SBC A,[m]	Subtract Data Memory from ACC with Carry
Description	The contents of the specified Data Memory and the complement of the carry flag are subtracted from the Accumulator. The result is stored in the Accumulator. Note that if the result of subtraction is negative, the C flag will be cleared to 0, otherwise if the result is positive or zero, the C flag will be set to 1.
Operation	ACC ← ACC – [m] – \bar{C}
Affected flag(s)	OV, Z, AC, C, SC, CZ
SBC A, x	Subtract immediate data from ACC with Carry
Description	The immediate data and the complement of the carry flag are subtracted from the Accumulator. The result is stored in the Accumulator. Note that if the result of subtraction is negative, the C flag will be cleared to 0, otherwise if the result is positive or zero, the C flag will be set to 1.
Operation	ACC ← ACC – [m] – \bar{C}
Affected flag(s)	OV, Z, AC, C, SC, CZ
SBCM A,[m]	Subtract Data Memory from ACC with Carry and result in Data Memory
Description	The contents of the specified Data Memory and the complement of the carry flag are subtracted from the Accumulator. The result is stored in the Data Memory. Note that if the result of subtraction is negative, the C flag will be cleared to 0, otherwise if the result is positive or zero, the C flag will be set to 1.
Operation	[m] ← ACC – [m] – \bar{C}
Affected flag(s)	OV, Z, AC, C, SC, CZ
SDZ [m]	Skip if decrement Data Memory is 0
Description	The contents of the specified Data Memory are first decremented by 1. If the result is 0 the following instruction is skipped. As this requires the insertion of a dummy instruction while the next instruction is fetched, it is a two cycle instruction. If the result is not 0 the program proceeds with the following instruction.
Operation	[m] ← [m] – 1 Skip if [m]=0
Affected flag(s)	None
SDZA [m]	Skip if decrement Data Memory is zero with result in ACC
Description	The contents of the specified Data Memory are first decremented by 1. If the result is 0, the following instruction is skipped. The result is stored in the Accumulator but the specified Data Memory contents remain unchanged. As this requires the insertion of a dummy instruction while the next instruction is fetched, it is a two cycle instruction. If the result is not 0, the program proceeds with the following instruction.
Operation	ACC ← [m] – 1 Skip if ACC=0
Affected flag(s)	None

SET [m]	Set Data Memory
Description	Each bit of the specified Data Memory is set to 1.
Operation	$[m] \leftarrow FFH$
Affected flag(s)	None
SET [m].i	Set bit of Data Memory
Description	Bit i of the specified Data Memory is set to 1.
Operation	$[m].i \leftarrow 1$
Affected flag(s)	None
SIZ [m]	Skip if increment Data Memory is 0
Description	The contents of the specified Data Memory are first incremented by 1. If the result is 0, the following instruction is skipped. As this requires the insertion of a dummy instruction while the next instruction is fetched, it is a two cycle instruction. If the result is not 0 the program proceeds with the following instruction.
Operation	$[m] \leftarrow [m] + 1$ Skip if $[m]=0$
Affected flag(s)	None
SIZA [m]	Skip if increment Data Memory is zero with result in ACC
Description	The contents of the specified Data Memory are first incremented by 1. If the result is 0, the following instruction is skipped. The result is stored in the Accumulator but the specified Data Memory contents remain unchanged. As this requires the insertion of a dummy instruction while the next instruction is fetched, it is a two cycle instruction. If the result is not 0 the program proceeds with the following instruction.
Operation	$ACC \leftarrow [m] + 1$ Skip if $ACC=0$
Affected flag(s)	None
SNZ [m].i	Skip if Data Memory is not 0
Description	If the specified Data Memory is not 0, the following instruction is skipped. As this requires the insertion of a dummy instruction while the next instruction is fetched, it is a two cycle instruction. If the result is 0 the program proceeds with the following instruction.
Operation	Skip if $[m].i \neq 0$
Affected flag(s)	None
SNZ [m]	Skip if Data Memory is not 0
Description	If the specified Data Memory is not 0, the following instruction is skipped. As this requires the insertion of a dummy instruction while the next instruction is fetched, it is a two cycle instruction. If the result is 0 the program proceeds with the following instruction.
Operation	Skip if $[m] \neq 0$
Affected flag(s)	None
SUB A,[m]	Subtract Data Memory from ACC
Description	The specified Data Memory is subtracted from the contents of the Accumulator. The result is stored in the Accumulator. Note that if the result of subtraction is negative, the C flag will be cleared to 0, otherwise if the result is positive or zero, the C flag will be set to 1.
Operation	$ACC \leftarrow ACC - [m]$
Affected flag(s)	OV, Z, AC, C, SC, CZ

SUBM A,[m]	Subtract Data Memory from ACC with result in Data Memory
Description	The specified Data Memory is subtracted from the contents of the Accumulator. The result is stored in the Data Memory. Note that if the result of subtraction is negative, the C flag will be cleared to 0, otherwise if the result is positive or zero, the C flag will be set to 1.
Operation	$[m] \leftarrow ACC - [m]$
Affected flag(s)	OV, Z, AC, C, SC, CZ
SUB A,x	Subtract immediate data from ACC
Description	The immediate data specified by the code is subtracted from the contents of the Accumulator. The result is stored in the Accumulator. Note that if the result of subtraction is negative, the C flag will be cleared to 0, otherwise if the result is positive or zero, the C flag will be set to 1.
Operation	$ACC \leftarrow ACC - x$
Affected flag(s)	OV, Z, AC, C, SC, CZ
SWAP [m]	Swap nibbles of Data Memory
Description	The low-order and high-order nibbles of the specified Data Memory are interchanged.
Operation	$[m].3 \sim [m].0 \leftrightarrow [m].7 \sim [m].4$
Affected flag(s)	None
SWAPA [m]	Swap nibbles of Data Memory with result in ACC
Description	The low-order and high-order nibbles of the specified Data Memory are interchanged. The result is stored in the Accumulator. The contents of the Data Memory remain unchanged.
Operation	$ACC.3 \sim ACC.0 \leftarrow [m].7 \sim [m].4$ $ACC.7 \sim ACC.4 \leftarrow [m].3 \sim [m].0$
Affected flag(s)	None
SZ [m]	Skip if Data Memory is 0
Description	If the contents of the specified Data Memory is 0, the following instruction is skipped. As this requires the insertion of a dummy instruction while the next instruction is fetched, it is a two cycle instruction. If the result is not 0 the program proceeds with the following instruction.
Operation	Skip if $[m]=0$
Affected flag(s)	None
SZA [m]	Skip if Data Memory is 0 with data movement to ACC
Description	The contents of the specified Data Memory are copied to the Accumulator. If the value is zero, the following instruction is skipped. As this requires the insertion of a dummy instruction while the next instruction is fetched, it is a two cycle instruction. If the result is not 0 the program proceeds with the following instruction.
Operation	$ACC \leftarrow [m]$ Skip if $[m]=0$
Affected flag(s)	None
SZ [m].i	Skip if bit i of Data Memory is 0
Description	If bit i of the specified Data Memory is 0, the following instruction is skipped. As this requires the insertion of a dummy instruction while the next instruction is fetched, it is a two cycle instruction. If the result is not 0, the program proceeds with the following instruction.
Operation	Skip if $[m].i=0$
Affected flag(s)	None

TABRD [m]	Read table (specific page) to TBLH and Data Memory
Description	The low byte of the program code (specific page) addressed by the table pointer pair (TBLP and TBHP) is moved to the specified Data Memory and the high byte moved to TBLH.
Operation	[m] ← program code (low byte) TBLH ← program code (high byte)
Affected flag(s)	None
TABRDL [m]	Read table (last page) to TBLH and Data Memory
Description	The low byte of the program code (last page) addressed by the table pointer (TBLP) is moved to the specified Data Memory and the high byte moved to TBLH.
Operation	[m] ← program code (low byte) TBLH ← program code (high byte)
Affected flag(s)	None
ITABRD [m]	Increment table pointer low byte first and read table to TBLH and Data Memory
Description	Increment table pointer low byte, TBLP, first and then the program code addressed by the table pointer (TBHP and TBLP) is moved to the specified Data Memory and the high byte moved to TBLH.
Operation	[m] ← program code (low byte) TBLH ← program code (high byte)
Affected flag(s)	None
ITABRDL [m]	Increment table pointer low byte first and read table (last page) to TBLH and Data Memory
Description	Increment table pointer low byte, TBLP, first and then the low byte of the program code (last page) addressed by the table pointer (TBLP) is moved to the specified Data Memory and the high byte moved to TBLH.
Operation	[m] ← program code (low byte) TBLH ← program code (high byte)
Affected flag(s)	None
XOR A,[m]	Logical XOR Data Memory to ACC
Description	Data in the Accumulator and the specified Data Memory perform a bitwise logical XOR operation. The result is stored in the Accumulator.
Operation	ACC ← ACC "XOR" [m]
Affected flag(s)	Z
XORM A,[m]	Logical XOR ACC to Data Memory
Description	Data in the specified Data Memory and the Accumulator perform a bitwise logical XOR operation. The result is stored in the Data Memory.
Operation	[m] ← ACC "XOR" [m]
Affected flag(s)	Z
XOR A,x	Logical XOR immediate data to ACC
Description	Data in the Accumulator and the specified immediate data perform a bitwise logical XOR operation. The result is stored in the Accumulator.
Operation	ACC ← ACC "XOR" x
Affected flag(s)	Z

Extended Instruction Definition

The extended instructions are used to directly access the data stored in any data memory sections.

LADC A,[m]	Add Data Memory to ACC with Carry
Description	The contents of the specified Data Memory, Accumulator and the carry flag are added. The result is stored in the Accumulator.
Operation	$ACC \leftarrow ACC + [m] + C$
Affected flag(s)	OV, Z, AC, C, SC
LADCM A,[m]	Add ACC to Data Memory with Carry
Description	The contents of the specified Data Memory, Accumulator and the carry flag are added. The result is stored in the specified Data Memory.
Operation	$[m] \leftarrow ACC + [m] + C$
Affected flag(s)	OV, Z, AC, C, SC
LADD A,[m]	Add Data Memory to ACC
Description	The contents of the specified Data Memory and the Accumulator are added. The result is stored in the Accumulator.
Operation	$ACC \leftarrow ACC + [m]$
Affected flag(s)	OV, Z, AC, C, SC
LADDM A,[m]	Add ACC to Data Memory
Description	The contents of the specified Data Memory and the Accumulator are added. The result is stored in the specified Data Memory.
Operation	$[m] \leftarrow ACC + [m]$
Affected flag(s)	OV, Z, AC, C, SC
LAND A,[m]	Logical AND Data Memory to ACC
Description	Data in the Accumulator and the specified Data Memory perform a bitwise logical AND operation. The result is stored in the Accumulator.
Operation	$ACC \leftarrow ACC \text{ "AND" } [m]$
Affected flag(s)	Z
LANDM A,[m]	Logical AND ACC to Data Memory
Description	Data in the specified Data Memory and the Accumulator perform a bitwise logical AND operation. The result is stored in the Data Memory.
Operation	$[m] \leftarrow ACC \text{ "AND" } [m]$
Affected flag(s)	Z
LCLR [m]	Clear Data Memory
Description	Each bit of the specified Data Memory is cleared to 0.
Operation	$[m] \leftarrow 00H$
Affected flag(s)	None
LCLR [m].i	Clear bit of Data Memory
Description	Bit i of the specified Data Memory is cleared to 0.
Operation	$[m].i \leftarrow 0$
Affected flag(s)	None

LCPL [m]	Complement Data Memory
Description	Each bit of the specified Data Memory is logically complemented (1's complement). Bits which previously contained a 1 are changed to 0 and vice versa.
Operation	$[m] \leftarrow \overline{[m]}$
Affected flag(s)	Z
LCPLA [m]	Complement Data Memory with result in ACC
Description	Each bit of the specified Data Memory is logically complemented (1's complement). Bits which previously contained a 1 are changed to 0 and vice versa. The complemented result is stored in the Accumulator and the contents of the Data Memory remain unchanged.
Operation	$ACC \leftarrow \overline{[m]}$
Affected flag(s)	Z
LDAA [m]	Decimal-Adjust ACC for addition with result in Data Memory
Description	Convert the contents of the Accumulator value to a BCD (Binary Coded Decimal) value resulting from the previous addition of two BCD variables. If the low nibble is greater than 9 or if AC flag is set, then a value of 6 will be added to the low nibble. Otherwise the low nibble remains unchanged. If the high nibble is greater than 9 or if the C flag is set, then a value of 6 will be added to the high nibble. Essentially, the decimal conversion is performed by adding 00H, 06H, 60H or 66H depending on the Accumulator and flag conditions. Only the C flag may be affected by this instruction which indicates that if the original BCD sum is greater than 100, it allows multiple precision decimal addition.
Operation	$[m] \leftarrow ACC + 00H$ or $[m] \leftarrow ACC + 06H$ or $[m] \leftarrow ACC + 60H$ or $[m] \leftarrow ACC + 66H$
Affected flag(s)	C
LDEC [m]	Decrement Data Memory
Description	Data in the specified Data Memory is decremented by 1.
Operation	$[m] \leftarrow [m] - 1$
Affected flag(s)	Z
LDECA [m]	Decrement Data Memory with result in ACC
Description	Data in the specified Data Memory is decremented by 1. The result is stored in the Accumulator. The contents of the Data Memory remain unchanged.
Operation	$ACC \leftarrow [m] - 1$
Affected flag(s)	Z
LINC [m]	Increment Data Memory
Description	Data in the specified Data Memory is incremented by 1.
Operation	$[m] \leftarrow [m] + 1$
Affected flag(s)	Z
LINCA [m]	Increment Data Memory with result in ACC
Description	Data in the specified Data Memory is incremented by 1. The result is stored in the Accumulator. The contents of the Data Memory remain unchanged.
Operation	$ACC \leftarrow [m] + 1$
Affected flag(s)	Z

LMOV A,[m]	Move Data Memory to ACC
Description	The contents of the specified Data Memory are copied to the Accumulator.
Operation	$ACC \leftarrow [m]$
Affected flag(s)	None
LMOV [m],A	Move ACC to Data Memory
Description	The contents of the Accumulator are copied to the specified Data Memory.
Operation	$[m] \leftarrow ACC$
Affected flag(s)	None
LOR A,[m]	Logical OR Data Memory to ACC
Description	Data in the Accumulator and the specified Data Memory perform a bitwise logical OR operation. The result is stored in the Accumulator.
Operation	$ACC \leftarrow ACC \text{ "OR" } [m]$
Affected flag(s)	Z
LORM A,[m]	Logical OR ACC to Data Memory
Description	Data in the specified Data Memory and the Accumulator perform a bitwise logical OR operation. The result is stored in the Data Memory.
Operation	$[m] \leftarrow ACC \text{ "OR" } [m]$
Affected flag(s)	Z
LRL [m]	Rotate Data Memory left
Description	The contents of the specified Data Memory are rotated left by 1 bit with bit 7 rotated into bit 0.
Operation	$[m].(i+1) \leftarrow [m].i; (i=0\sim 6)$ $[m].0 \leftarrow [m].7$
Affected flag(s)	None
LRLA [m]	Rotate Data Memory left with result in ACC
Description	The contents of the specified Data Memory are rotated left by 1 bit with bit 7 rotated into bit 0. The rotated result is stored in the Accumulator and the contents of the Data Memory remain unchanged.
Operation	$ACC.(i+1) \leftarrow [m].i; (i=0\sim 6)$ $ACC.0 \leftarrow [m].7$
Affected flag(s)	None
LRLC [m]	Rotate Data Memory left through Carry
Description	The contents of the specified Data Memory and the carry flag are rotated left by 1 bit. Bit 7 replaces the Carry bit and the original carry flag is rotated into bit 0.
Operation	$[m].(i+1) \leftarrow [m].i; (i=0\sim 6)$ $[m].0 \leftarrow C$ $C \leftarrow [m].7$
Affected flag(s)	C
LRLCA [m]	Rotate Data Memory left through Carry with result in ACC
Description	Data in the specified Data Memory and the carry flag are rotated left by 1 bit. Bit 7 replaces the Carry bit and the original carry flag is rotated into the bit 0. The rotated result is stored in the Accumulator and the contents of the Data Memory remain unchanged.
Operation	$ACC.(i+1) \leftarrow [m].i; (i=0\sim 6)$ $ACC.0 \leftarrow C$ $C \leftarrow [m].7$
Affected flag(s)	C

LRR [m]	Rotate Data Memory right
Description	The contents of the specified Data Memory are rotated right by 1 bit with bit 0 rotated into bit 7.
Operation	$[m].i \leftarrow [m].(i+1); (i=0\sim 6)$ $[m].7 \leftarrow [m].0$
Affected flag(s)	None
LRRRA [m]	Rotate Data Memory right with result in ACC
Description	Data in the specified Data Memory is rotated right by 1 bit with bit 0 rotated into bit 7. The rotated result is stored in the Accumulator and the contents of the Data Memory remain unchanged.
Operation	$ACC.i \leftarrow [m].(i+1); (i=0\sim 6)$ $ACC.7 \leftarrow [m].0$
Affected flag(s)	None
LRRRC [m]	Rotate Data Memory right through Carry
Description	The contents of the specified Data Memory and the carry flag are rotated right by 1 bit. Bit 0 replaces the Carry bit and the original carry flag is rotated into bit 7.
Operation	$[m].i \leftarrow [m].(i+1); (i=0\sim 6)$ $[m].7 \leftarrow C$ $C \leftarrow [m].0$
Affected flag(s)	C
LRRCA [m]	Rotate Data Memory right through Carry with result in ACC
Description	Data in the specified Data Memory and the carry flag are rotated right by 1 bit. Bit 0 replaces the Carry bit and the original carry flag is rotated into bit 7. The rotated result is stored in the Accumulator and the contents of the Data Memory remain unchanged.
Operation	$ACC.i \leftarrow [m].(i+1); (i=0\sim 6)$ $ACC.7 \leftarrow C$ $C \leftarrow [m].0$
Affected flag(s)	C
LSBC A,[m]	Subtract Data Memory from ACC with Carry
Description	The contents of the specified Data Memory and the complement of the carry flag are subtracted from the Accumulator. The result is stored in the Accumulator. Note that if the result of subtraction is negative, the C flag will be cleared to 0, otherwise if the result is positive or zero, the C flag will be set to 1.
Operation	$ACC \leftarrow ACC - [m] - \bar{C}$
Affected flag(s)	OV, Z, AC, C, SC, CZ
LSBCM A,[m]	Subtract Data Memory from ACC with Carry and result in Data Memory
Description	The contents of the specified Data Memory and the complement of the carry flag are subtracted from the Accumulator. The result is stored in the Data Memory. Note that if the result of subtraction is negative, the C flag will be cleared to 0, otherwise if the result is positive or zero, the C flag will be set to 1.
Operation	$[m] \leftarrow ACC - [m] - \bar{C}$
Affected flag(s)	OV, Z, AC, C, SC, CZ

LSDZ [m]	Skip if decrement Data Memory is 0
Description	The contents of the specified Data Memory are first decremented by 1. If the result is 0 the following instruction is skipped. As this requires the insertion of a dummy instruction while the next instruction is fetched, it is a two cycle instruction. If the result is not 0 the program proceeds with the following instruction.
Operation	$[m] \leftarrow [m] - 1$ Skip if $[m]=0$
Affected flag(s)	None
LSDZA [m]	Skip if decrement Data Memory is zero with result in ACC
Description	The contents of the specified Data Memory are first decremented by 1. If the result is 0, the following instruction is skipped. The result is stored in the Accumulator but the specified Data Memory contents remain unchanged. As this requires the insertion of a dummy instruction while the next instruction is fetched, it is a two cycle instruction. If the result is not 0, the program proceeds with the following instruction.
Operation	$ACC \leftarrow [m] - 1$ Skip if $ACC=0$
Affected flag(s)	None
LSET [m]	Set Data Memory
Description	Each bit of the specified Data Memory is set to 1.
Operation	$[m] \leftarrow FFH$
Affected flag(s)	None
LSET [m].i	Set bit of Data Memory
Description	Bit i of the specified Data Memory is set to 1.
Operation	$[m].i \leftarrow 1$
Affected flag(s)	None
LSIZ [m]	Skip if increment Data Memory is 0
Description	The contents of the specified Data Memory are first incremented by 1. If the result is 0, the following instruction is skipped. As this requires the insertion of a dummy instruction while the next instruction is fetched, it is a two cycle instruction. If the result is not 0 the program proceeds with the following instruction.
Operation	$[m] \leftarrow [m] + 1$ Skip if $[m]=0$
Affected flag(s)	None
LSIZA [m]	Skip if increment Data Memory is zero with result in ACC
Description	The contents of the specified Data Memory are first incremented by 1. If the result is 0, the following instruction is skipped. The result is stored in the Accumulator but the specified Data Memory contents remain unchanged. As this requires the insertion of a dummy instruction while the next instruction is fetched, it is a two cycle instruction. If the result is not 0 the program proceeds with the following instruction.
Operation	$ACC \leftarrow [m] + 1$ Skip if $ACC=0$
Affected flag(s)	None
LSNZ [m].i	Skip if Data Memory is not 0
Description	If the specified Data Memory is not 0, the following instruction is skipped. As this requires the insertion of a dummy instruction while the next instruction is fetched, it is a two cycle instruction. If the result is 0 the program proceeds with the following instruction.
Operation	Skip if $[m].i \neq 0$
Affected flag(s)	None

LSNZ [m]	Skip if Data Memory is not 0
Description	If the content of the specified Data Memory is not 0, the following instruction is skipped. As this requires the insertion of a dummy instruction while the next instruction is fetched, it is a two cycle instruction. If the result is 0 the program proceeds with the following instruction.
Operation	Skip if [m] ≠ 0
Affected flag(s)	None
LSUB A,[m]	Subtract Data Memory from ACC
Description	The specified Data Memory is subtracted from the contents of the Accumulator. The result is stored in the Accumulator. Note that if the result of subtraction is negative, the C flag will be cleared to 0, otherwise if the result is positive or zero, the C flag will be set to 1.
Operation	ACC ← ACC – [m]
Affected flag(s)	OV, Z, AC, C, SC, CZ
LSUBM A,[m]	Subtract Data Memory from ACC with result in Data Memory
Description	The specified Data Memory is subtracted from the contents of the Accumulator. The result is stored in the Data Memory. Note that if the result of subtraction is negative, the C flag will be cleared to 0, otherwise if the result is positive or zero, the C flag will be set to 1.
Operation	[m] ← ACC – [m]
Affected flag(s)	OV, Z, AC, C, SC, CZ
LSWAP [m]	Swap nibbles of Data Memory
Description	The low-order and high-order nibbles of the specified Data Memory are interchanged.
Operation	[m].3~[m].0 ↔ [m].7~[m].4
Affected flag(s)	None
LSWAPA [m]	Swap nibbles of Data Memory with result in ACC
Description	The low-order and high-order nibbles of the specified Data Memory are interchanged. The result is stored in the Accumulator. The contents of the Data Memory remain unchanged.
Operation	ACC.3~ACC.0 ← [m].7~[m].4 ACC.7~ACC.4 ← [m].3~[m].0
Affected flag(s)	None
LSZ [m]	Skip if Data Memory is 0
Description	If the contents of the specified Data Memory is 0, the following instruction is skipped. As this requires the insertion of a dummy instruction while the next instruction is fetched, it is a two cycle instruction. If the result is not 0 the program proceeds with the following instruction.
Operation	Skip if [m]=0
Affected flag(s)	None
LSZA [m]	Skip if Data Memory is 0 with data movement to ACC
Description	The contents of the specified Data Memory are copied to the Accumulator. If the value is zero, the following instruction is skipped. As this requires the insertion of a dummy instruction while the next instruction is fetched, it is a two cycle instruction. If the result is not 0 the program proceeds with the following instruction.
Operation	ACC ← [m] Skip if [m]=0
Affected flag(s)	None

LSZ [m].i	Skip if bit i of Data Memory is 0
Description	If bit i of the specified Data Memory is 0, the following instruction is skipped. As this requires the insertion of a dummy instruction while the next instruction is fetched, it is a two cycle instruction. If the result is not 0, the program proceeds with the following instruction.
Operation	Skip if [m].i=0
Affected flag(s)	None
LTABRD [m]	Read table (current page) to TBLH and Data Memory
Description	The low byte of the program code (current page) addressed by the table pointer (TBLP) is moved to the specified Data Memory and the high byte moved to TBLH.
Operation	[m] ← program code (low byte) TBLH ← program code (high byte)
Affected flag(s)	None
LTABRDL [m]	Read table (last page) to TBLH and Data Memory
Description	The low byte of the program code (last page) addressed by the table pointer (TBLP) is moved to the specified Data Memory and the high byte moved to TBLH.
Operation	[m] ← program code (low byte) TBLH ← program code (high byte)
Affected flag(s)	None
LITABRD [m]	Increment table pointer low byte first and read table to TBLH and Data Memory
Description	Increment table pointer low byte, TBLP, first and then the program code addressed by the table pointer (TBLP and TBLP) is moved to the specified Data Memory and the high byte moved to TBLH.
Operation	[m] ← program code (low byte) TBLH ← program code (high byte)
Affected flag(s)	None
LITABRDL [m]	Increment table pointer low byte first and read table (last page) to TBLH and Data Memory
Description	Increment table pointer low byte, TBLP, first and then the low byte of the program code (last page) addressed by the table pointer (TBLP) is moved to the specified Data Memory and the high byte moved to TBLH.
Operation	[m] ← program code (low byte) TBLH ← program code (high byte)
Affected flag(s)	None
LXOR A,[m]	Logical XOR Data Memory to ACC
Description	Data in the Accumulator and the specified Data Memory perform a bitwise logical XOR operation. The result is stored in the Accumulator.
Operation	ACC ← ACC "XOR" [m]
Affected flag(s)	Z
LXORM A,[m]	Logical XOR ACC to Data Memory
Description	Data in the specified Data Memory and the Accumulator perform a bitwise logical XOR operation. The result is stored in the Data Memory.
Operation	[m] ← ACC "XOR" [m]
Affected flag(s)	Z

Package Information

Note that the package information provided here is for consultation purposes only. As this information may be updated at regular intervals users are reminded to consult the [Holtek website](#) for the latest version of the [Package/Carton Information](#).

Additional supplementary information with regard to packaging is listed below. Click on the relevant section to be transferred to the relevant website page.

- Package Information (include Outline Dimensions, Product Tape and Reel Specifications)
- The Operation Instruction of Packing Materials
- Carton information

100-pin LQFP (14mm×14mm) Outline Dimensions

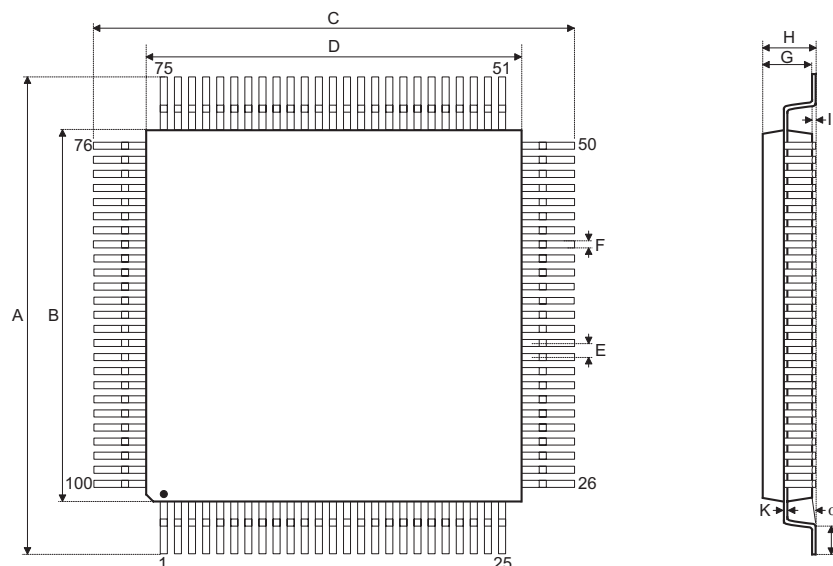

Symbol	Dimensions in inch		
	Min.	Nom.	Max.
A	—	0.630 BSC	—
B	—	0.551 BSC	—
C	—	0.630 BSC	—
D	—	0.551 BSC	—
E	—	0.020 BSC	—
F	0.007	0.009	0.011
G	0.053	0.055	0.057
H	—	—	0.063
I	0.002	—	0.006
J	0.018	0.024	0.030
K	0.004	—	0.008
α	0°	—	7°

Symbol	Dimensions in mm		
	Min.	Nom.	Max.
A	—	16.00 BSC	—
B	—	14.00 BSC	—
C	—	16.00 BSC	—
D	—	14.00 BSC	—
E	—	0.50 BSC	—
F	0.17	0.22	0.27
G	1.35	1.40	1.45
H	—	—	1.60
I	0.05	—	0.15
J	0.45	0.60	0.75
K	0.09	—	0.20
α	0°	—	7°

Copyright© 2019 by HOLTEK SEMICONDUCTOR INC.

The information appearing in this Data Sheet is believed to be accurate at the time of publication. However, Holtek assumes no responsibility arising from the use of the specifications described. The applications mentioned herein are used solely for the purpose of illustration and Holtek makes no warranty or representation that such applications will be suitable without further modification, nor recommends the use of its products for application that may present a risk to human life due to malfunction or otherwise. Holtek's products are not authorized for use as critical components in life support devices or systems. Holtek reserves the right to alter its products without prior notification. For the most up-to-date information, please visit our web site at <http://www.holtek.com>.