



Brushless DC Motor Flash MCU

HT66FM5230

Revision: V1.10 Date: December 21, 2016

www.holtek.com

Table of Contents

Features	7
CPU Features	7
Peripheral Features.....	7
General Description	8
Block Diagram	8
Pin Assignment	9
Pin Descriptions	10
Absolute Maximum Ratings	12
D.C. Characteristics	12
A.C. Characteristics	13
HIRC Frequency Accuracy over Device V_{DD} and Temperature	13
A/D Converter Characteristics	14
D/A Converter Characteristics	14
8-bit R-2R D/A Converter (Analog Condition $V_{DD}=5V$, $C_L=10pF$)	15
Operational Amplifier Characteristics	15
Comparator Electrical Characteristics	16
Power on Reset Electrical Characteristics	16
System Architecture	17
Clocking and Pipelining.....	17
Program Counter.....	18
Stack	19
Arithmetic and Logic Unit – ALU	19
Flash Program Memory	20
Structure.....	20
Special Vectors	20
Look-up Table.....	20
Table Program Example.....	21
In Circuit Programming	22
On-Chip Debug Support – OCDS	23
RAM Data Memory	23
Structure.....	23
Special Function Register Description	25
Indirect Addressing Registers – IAR0, IAR1	25
Memory Pointers – MP0, MP1	25
Bank Pointer – BP.....	26
Accumulator – ACC.....	26
Program Counter Low Register – PCL.....	26
Look-up Table Registers – TBLP, TBHP, TBLH.....	26
Status Register – STATUS.....	27

EEPROM Data Memory	29
EEPROM Data Memory Structure	29
EEPROM Registers	29
Reading Data from the EEPROM	31
Writing Data to the EEPROM.....	31
Write Protection.....	31
EEPROM Interrupt	31
Programming Considerations.....	31
Oscillator	33
Oscillator Overview	33
System Clock Configurations.....	33
Internal 20MHz RC Oscillator – HIRC.....	34
Internal 32kHz Oscillator – LIRC.....	34
Supplementary Clocks	34
Operating Modes and System Clocks	35
System Clocks	35
System Operation Modes.....	36
Control Register	37
Operating Mode Switching	39
NORMAL Mode to SLOW Mode Switching.....	39
SLOW Mode to NORMAL Mode Switching	39
Entering the SLEEP Mode	41
Entering the IDLE0 Mode.....	41
Entering the IDLE1 Mode.....	41
Standby Current Considerations	42
Wake-up	42
Watchdog Timer	43
Watchdog Timer Clock Source.....	43
Watchdog Timer Control Register	43
Watchdog Timer Operation	44
Reset and Initialisation	45
Reset Functions	45
Reset Initial Conditions	47
Input/Output Ports	51
I/O Register List	51
Pull-high Resistors	51
Port A Wake-up	52
I/O Port Control Registers	53
Pin-sharing Functions	54
Pin-remapping Functions	56
Pin-remapping Registers.....	56
I/O Pin Structures.....	57
Programming Considerations.....	58

Timer Modules – TM	58
Introduction	58
TM Operation	59
TM Clock Source.....	59
TM Interrupts.....	59
TM External Pins.....	59
Programming Considerations.....	60
Compact Type TM – CTM	61
Compact TM Operation.....	61
Compact Type TM Register Description.....	62
Compact Type TM Operating Modes	70
Compare Match Output Mode.....	70
Timer/Counter Mode	73
PWM Output Mode.....	73
Buzzer Control	75
Standard Type TM – STM	76
Standard TM Operation.....	76
Standard Type TM Register Description	77
Standard Type TM Operating Modes	81
Compare Output Mode.....	81
Timer/Counter Mode	84
PWM Output Mode.....	84
Single Pulse Mode	87
Capture Input Mode	87
Capture Timer Module – CAPTM	90
Capture Timer Overview	90
Capture Timer Register Description	90
Capture Timer Operation.....	94
Capture Mode Operation.....	94
Compare Mode Operation.....	94
Noise Filter	95
Noise Filter Registers Description.....	95
Comparators	96
Comparators Block Diagram	96
Comparator Operation	97
Analog to Digital Converter	98
A/D Overview	98
A/D Converter Register Description	99
A/D Converter Data Registers – ADRL, ADRH	100
A/D Converter Control Registers – ADCR0, ADCR1, ADCR2, ADDL	100
A/D Converter Boundary Registers – ADLVDL, ADLVDH, ADHVDL, ADHVDH	102
A/D Operation	103
Summary of A/D Conversion Steps.....	104

Programming Considerations.....	105
A/D Transfer Function	105
A/D Programming Examples.....	106
Over-current Detection.....	108
Over-current Functional Description	108
Over-current Register Description.....	108
BLDC Motor Control Circuit.....	110
Functional Description.....	110
PWM Counter Control Circuit	111
Mask Function.....	115
Other Functions.....	120
Hall Sensor Decoder	122
Motor Protection Function	130
I²C Interface	135
I ² C Interface Operation	135
I ² C Registers	136
I ² C Bus Communication	139
I ² C Bus Start Signal	140
Slave Address	140
I ² C Bus Read/Write Signal	140
I ² C Bus Slave Address Acknowledge Signal	141
I ² C Bus Data and Acknowledge Signal	141
I ² C Time-out Control.....	142
Interrupts	143
Interrupt Registers.....	143
Interrupt Operation.....	149
External Interrupt 0.....	151
External Interrupt 1.....	151
Comparator Interrupt.....	151
Time Base Interrupt.....	151
Multi-function Interrupt	152
A/D Converter Interrupt.....	153
PWM Module Interrupts	153
CAPTM Module Interrupt	153
TM Interrupt.....	153
EEPROM Interrupt.....	154
LVD Interrupt.....	154
I ² C Interrupt.....	154
Interrupt Wake-up Function.....	154
Programming Considerations.....	155
Low Voltage Detector – LVD	156
LVD Register	156
LVD Operation.....	157

Application Circuits	158
Three Phase BLDC Hall Sensor Solution ($V_B=24V$).....	158
Three Phase BLDC Hall Sensorless Solution ($V_B=24V$)	158
Single Phase BLDC Hall Sensor Solution ($V_B=12V$)	159
Single Phase BLDC Hall Sensorless Solution ($V_B=12V$).....	159
Instruction Set	160
Introduction	160
Instruction Timing	160
Moving and Transferring Data	160
Arithmetic Operations.....	160
Logical and Rotate Operation	161
Branches and Control Transfer	161
Bit Operations	161
Table Read Operations	161
Other Operations.....	161
Instruction Set Summary.....	162
Instruction Definition	164
Package Information	173
16-pin NSOP (150mil) Outline Dimensions	174
20-pin SSOP (150mil) Outline Dimensions	175

Features

CPU Features

- Operating Voltage:
 $f_{SYS} = 32\text{kHz} \sim 20\text{MHz}$: 4.5V~5.5V
- Up to 0.2 μs instruction cycle with 20MHz system clock at $V_{DD}=5\text{V}$
- Power down and wake-up functions to reduce power consumption
- Oscillators:
Internal 20MHz – HIRC
Internal 32kHz – LIRC
- Multi-mode operation: NORMAL, SLOW, IDLE and SLEEP
- All instructions executed in one or two instruction cycles
- Table read instructions
- 63 powerful instructions
- 6-level subroutine nesting
- Bit manipulation instruction

Peripheral Features

- Flash Program Memory: 2K \times 16
- RAM Data Memory: 256 \times 8
- True EEPROM Memory: 32 \times 8
- Watchdog Timer function
- Up to 18 bidirectional I/O lines
- Four pin-shared external interrupts
- Single 10-bit CTM
- Single 16-bit CTM
- Single 10-bit STM
- Single 16-bit CAPTM for motor protect
- 3-channel 10-bit PWM with complementary outputs for BLDC application
- 6-channel 10-bit resolution A/D converter
- Time-Base function for generation of fixed time interrupt signal
- Single operational Amplifier for current detection
- Four comparators with interrupt functions
- Single 8-bit D/A Converter
- I²C interface
- Low voltage reset function
- Low voltage detect function
- Package types: 16-pin NSOP-A, 20-pin SSOP-A

General Description

This device is Flash Memory with 8-bit high performance RISC architecture microcontroller device which includes a host of fully integrated special features specifically designed for the brushless DC motor applications.

The advantages of low power consumption, I/O flexibility, Multiple and extremely flexible Timer Modules, oscillator options, multi-channel A/D and D/A Converter, Pulse Width Modulation function, 16-bit Capture Timer Module function, comparator functions, Motor Protect Module, Time Base function, LVD, True EEPROM, power-down and wake-up functions, Communication with the outside world is catered for by including fully integrated I2C interface functions, although especially designed for brushless DC motor applications, the enhanced versatility of this device also makes it applicable for using in a wide range of A/D application possibilities such as sensor signal processing, motor driving, industrial control, consumer products, subsystem controllers, etc.

Block Diagram

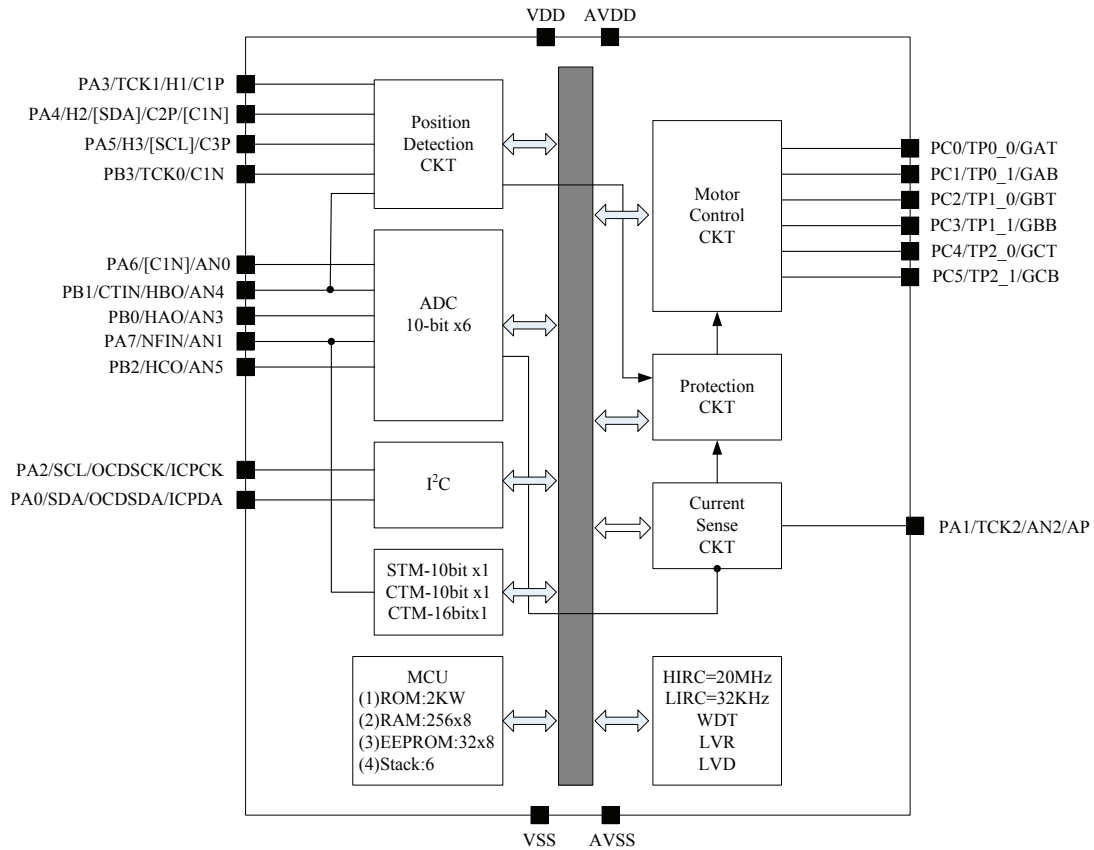

Pin Assignment

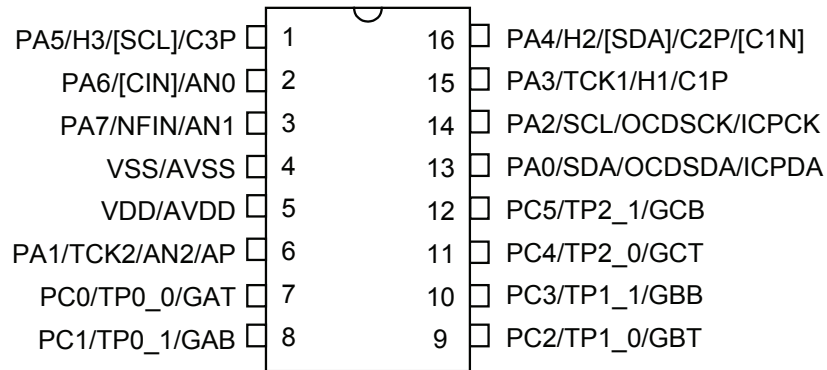

HT66FM5230
16NSOP-A

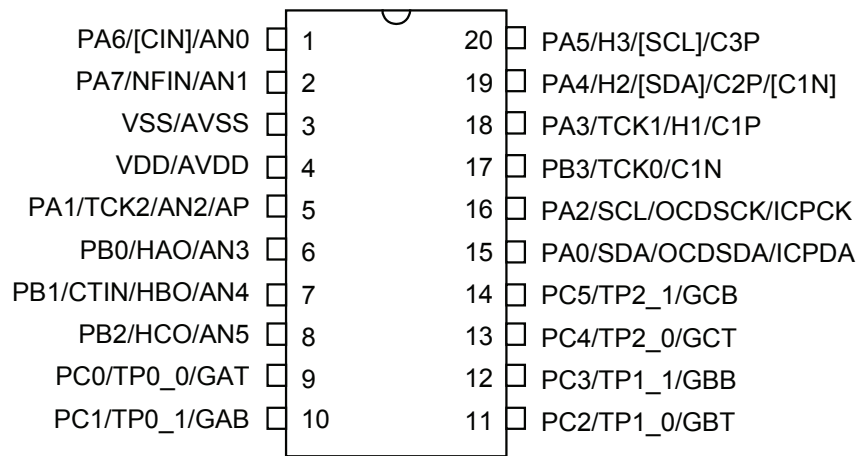

HT66FM5230
20SSOP-A

- Note: 1. If the pin-shared pin functions have multiple outputs simultaneously, its pin names at the right side of the "/" sign can be used for higher priority
2. VDD&AVDD means the VDD and AVDD are the double bonding.
3. VSS&AVSS means the VSS and AVSS are the double bonding.

Pin Descriptions

Pin Name	Function	OP	I/T	O/T	Description
PA0/SDA/ OCDSDA/ICPDA	PA0	PAPU PAWU	ST	CMOS	Bidirectional 8-bit I/O port. Register enabled pull-up and wake-up.
	SDA	PAPS0	ST	NMOS	I ² C data
	OCDSDA	—	ST	CMOS	On-chip debug support data/address pin
	ICPDA	—	ST	CMOS	In-circuit programming support data/address pin
PA1/TCK2/AN2/ AP	PA1	PAPU PAWU	ST	CMOS	Bidirectional 8-bit I/O port. Register enabled pull-up and wake-up.
	TCK2	PAPS0	ST	—	TM2 input
	AN2	PAPS0	AN	—	A/D channel 2
	AP	PAPS0	ST	—	Operational amplifier input
PA2/SCL/ OCDSCK/ICPCK	PA2	PAPU PAWU	ST	CMOS	Bidirectional 8-bit I/O port. Register enabled pull-up and wake-up.
	SCL	PAPS0	ST	NMOS	I ² C clock
	OCDSCK	—	ST	—	On-chip debug programming clock pin
	ICPCK	—	ST	—	In-circuit programming clock pin
PA3/TCK1/H1/ C1P	PA3	PAPU PAWU	ST	CMOS	Bidirectional 8-bit I/O port. Register enabled pull-up and wake-up.
	TCK1	PAPS0	ST	—	TM1 input
	H1	PAPS0	ST	—	HALL Sensor input
	C1P	PAPS0	AN	—	Comparator 1 input
PA4/H2/[SDA]/ C2P/[C1N]	PA4	PAPU PAWU	ST	CMOS	Bidirectional 8-bit I/O port. Register enabled pull-up and wake-up.
	H2	PAPS1	ST	—	HALL Sensor input
	SDA	PAPS1	ST	NMOS	I ² C data
	C2P	PAPS1	AN	—	Comparator 2 input
	C1N	PAPS1	AN	—	Comparator 1 input
PA5/H3/[SCL]/ C3P	PA5	PAPU PAWU	ST	CMOS	Bidirectional 8-bit I/O port. Register enabled pull-up and wake-up.
	H3	PAPS1	ST	—	HALL Sensor input
	SCL	PAPS1	ST	NMOS	I ² C clock
	C3P	PAPS1	—	CMOS	Comparator 3 input
PA6/[C1N]/AN0	PA6	PAPU PAWU	ST	CMOS	Bidirectional 8-bit I/O port. Register enabled pull-up and wake-up.
	C1N	PAPS1	AN	—	Comparator 1 input
	AN0	PAPS1	AN	—	A/D channel 0
PA7/NFIN/AN1	PA7	PAPU PAWU	ST	CMOS	Bidirectional 8-bit I/O port. Register enabled pull-up and wake-up.
	NFIN	PAPS1	ST	—	External interrupt 1 input
	AN1	PAPS1	AN	—	A/D channel 1
PB0/HAO/AN3	PB0	PBPU	ST	CMOS	Bidirectional 8-bit I/O port. Register enabled pull-up.
	HAO	PBPS0	—	CMOS	Test pin for SA
	AN3	PBPS0	AN	—	A/D channel 3
PB1/CTIN/HBO/ AN4	PB1	PBPU	ST	CMOS	Bidirectional 8-bit I/O port. Register enabled pull-up.
	CTIN	PBPS0	—	—	CAPTM input
	HBO	PBPS0	—	CMOS	Test pin for SB
	AN4	PBPS0	AN	—	A/D channel 4

Pin Name	Function	OP	I/T	O/T	Description
PB2/HCO/AN5	PB2	PBPU	ST	CMOS	Bidirectional 8-bit I/O port. Register enabled pull-up.
	HCO	PBPS0	—	CMOS	Test pin for SC
	AN5	PBPS0	AN	—	A/D channel 5
PB3/TCK0/C1N	PB3	PBPU	ST	CMOS	Bidirectional 8-bit I/O port. Register enabled pull-up.
	TCK0	PBPS0	ST	—	TM1 input
	C1N	PBPS0	ST	—	Comparator 1 input
PC0/TP0_0/GAT	PC0	PCPU	ST	CMOS	Bidirectional 8-bit I/O port. Register enabled pull-up.
	TP0_0	PCPS0	ST	CMOS	TM0 I/O
	GAT	PCPS0	—	CMOS	Pulse Width Modulation complimentary output
PC1/TP0_1/GAB	PC1	PCPU	ST	CMOS	Bidirectional 8-bit I/O port. Register enabled pull-up.
	TP0_1	PCPS0	ST	CMOS	TM0 I/O
	GAB	PCPS0	—	CMOS	Pulse Width Modulation complimentary output
PC2/TP1_0/GBT	PC2	PCPU	ST	CMOS	Bidirectional 8-bit I/O port. Register enabled pull-up.
	TP1_0	PCPS0	ST	CMOS	TM1 I/O
	GBT	PCPS0	—	CMOS	Pulse Width Modulation complimentary output
PC3/TP1_1/GBB	PC3	PCPU	ST	CMOS	Bidirectional 8-bit I/O port. Register enabled pull-up.
	TP1_1	PCPS0	ST	CMOS	TM1 I/O
	GBB	PCPS0	—	CMOS	Pulse Width Modulation complimentary output
PC4/TP2_0/GCT	PC4	PCPU	ST	CMOS	Bidirectional 8-bit I/O port. Register enabled pull-up.
	TP2_0	PCPS1	ST	CMOS	TM2 I/O
	GCT	PCPS1	—	CMOS	Pulse Width Modulation complimentary output
PC5/TP2_1/GCB	PC5	PCPU	ST	CMOS	Bidirectional 8-bit I/O port. Register enabled pull-up.
	TP2_1	PCPS1	ST	CMOS	TM2 I/O
	GCB	PCPS1	—	CMOS	Pulse Width Modulation complimentary output
VSS	VSS	—	PWR	—	Negative power supply, ground
AVSS	AVSS	—	PWR	—	Ground connection for A/D converter. The VSS and AVSS are the same pin at package
VDD	VDD	—	PWR	—	Positive power supply
AVDD	AVDD	—	PWR	—	Power supply connection for A/D converter. The VDD and AVDD are the same pin at package

Note: I/T: Input type O/T: Output type
 OP: Optional by configuration option (CO) or register option
 PWR: Power ST: Schmitt Trigger input
 CMOS: CMOS output; AN: Analog input pin
 VDD is the device power supply while AVDD is the ADC power supply.
 VSS is the device ground pin while AVSS is the ADC ground pin.
 As the Pin Description Summary table applies to the package type with the most pins, not all of the above listed pins may be present on package types with smaller numbers of pins.

Absolute Maximum Ratings

Supply Voltage	$V_{SS}-0.3V$ to $V_{SS}+6.0V$
Input Voltage	$V_{SS}-0.3V$ to $V_{DD}+0.3V$
Storage Temperature.....	$-50^{\circ}C$ to $125^{\circ}C$
Operating Temperature.....	$-40^{\circ}C$ to $85^{\circ}C$
I_{OH} Total	$-80mA$
I_{OL} Total	$80mA$
Total Power Dissipation	$500mW$

Note: These are stress ratings only. Stresses exceeding the range specified under "Absolute Maximum Ratings" may cause substantial damage to these devices. Functional operation of these devices at other conditions beyond those listed in the specification is not implied and prolonged exposure to extreme conditions may affect devices reliability.

D.C. Characteristics

$T_a=25^{\circ}C$

Symbol	Parameter	Test Conditions		Min.	Typ.	Max.	Unit
		V_{DD}	Conditions				
V_{DD}	Operating Voltage	—	$f_{SYS}=32 \sim 20000kHz$	4.5	—	5.5	V
I_{DD}	Operating Current (HIRC OSC)	5V	No load, $f_H=20MHz$, ADC off, WDT enable, Motor_CTL off	—	9	12	mA
I_{STB}	Standby Current	—	LIRC and LVR on, LVD off, WDT enable	—	60	100	μA
V_{IL}	Input Low Voltage for I/O Ports, TCKn, H1, H2, H3 and NFIN	—	—	0	—	$0.3V_{DD}$	V
V_{IH}	Input High Voltage for I/O Ports, TCKn, H1, H2, H3 and NFIN	—	—	$0.7V_{DD}$	—	V_{DD}	V
V_{LVR}	LVR Voltage Level	—	LVR Enable, 3.15V option	-5%	3.15	+5%	V
V_{LVD}	LVD Voltage Level	—	LV DEN=1, $V_{LVD}=3.6V$	-5%	3.6	+5%	V
V_{OL}	Output Low Voltage for I/O Ports	5V	$I_{OL}=20mA$	—	—	0.5	V
V_{OH}	Output High Voltage for I/O Ports	5V	$I_{OH}=-7.4mA$	4.5	—	—	V
R_{PH}	Pull-high Resistance for I/O Ports	5V	—	10	30	50	k Ω

A.C. Characteristics

Ta=25°C

Symbol	Parameter	Test Conditions		Min.	Typ.	Max.	Unit
		V _{DD}	Conditions				
f _{SYS}	System Clock	—	4.5V~5.5V	32	—	20000	kHz
f _{HIRC}	System Clock (HIRC)	4.5V~5.5V	Ta=-40°C~85°C	-12%	20	+4%	MHz
			Ta=-20°C~85°C	-9%	20	+4%	MHz
			Ta=25°C	-2%	20	+2%	MHz
f _{TIMER}	Timer Input Pin Frequency	—	—	—	—	4	f _{SYS}
t _{INT}	Interrupt Pulse Width	—	—	1	—	—	t _{SYS}
t _{LVR}	Low Voltage Width to Reset	—	—	120	240	480	μs
t _{LVD}	Low Voltage Width to Interrupt	—	—	20	45	90	μs
t _{LVDS}	LVDO stable time	—	—	15	—	—	μs
t _{EEERD}	EEPROM Read Time	—	—	—	45	90	μs
t _{EEEWR}	EEPROM Write Time	—	—	—	2	4	ms
t _{SST}	System Start-up Timer Period (Wake-up from HALT)	—	f _{SYS} =HIRC	—	15~16	—	t _{SYS}
t _{RSTD}	System Reset Delay Time (Power On Reset)	—	—	25	50	100	ms
	System Reset Delay Time (Any Reset except Power On Reset)	—	—	8.3	16.7	33.3	ms

Note: 1. t_{SYS}=1/f_{SYS}

- To maintain the accuracy of the internal HIRC oscillator frequency, a 0.1μF decoupling capacitor should be connected between V_{DD} and V_{SS} and located as close to the device as possible.

HIRC Frequency Accuracy over Device V_{DD} and Temperature

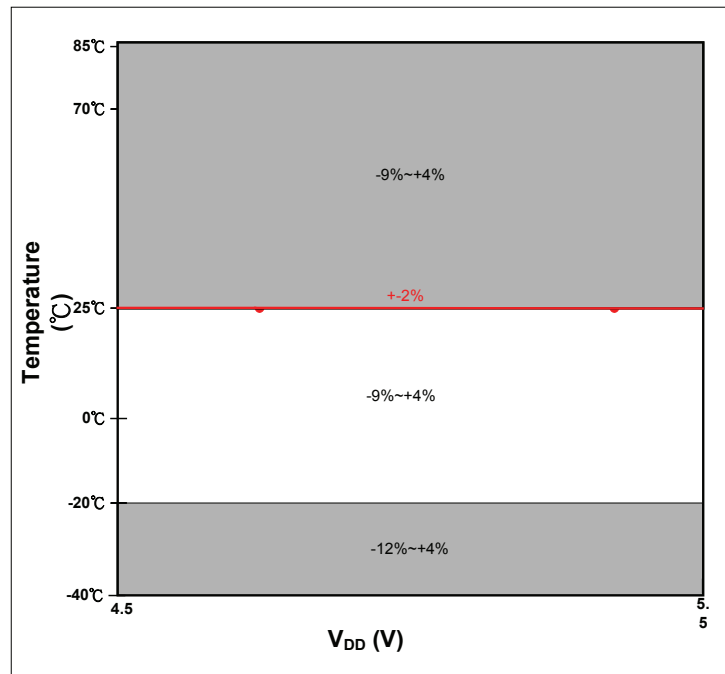

A/D Converter Characteristics

Ta=25°C

Symbol	Parameter	Test Conditions		Min.	Typ.	Max.	Unit
		V _{DD}	Condition				
AV _{DD}	A/D Converter Operating Voltage	—	—	V _{LVR}	5.0	5.5	V
I _{OP}	A/D Converter Operating Current	3V	—	—	0.8	—	mA
		5V	—	—	1	—	mA
I _{STBY}	ADC Standby Current	—	digital input no change	—	—	1	μA
V _{REF}	A/D Converter Reference Voltage	—	—	2	AV _{DD}	AV _{DD} +0.1	V
T _{conv}	A/D Conversion Time	—	—	14			T _{adck}
DNL	A/D Differential Non-linearity	4.5V	V _{REF} =AV _{DD} =V _{DD} , t _{AD} =0.2μs	-3	—	3	LSB
		5.5V	V _{REF} =AV _{DD} =V _{DD} , t _{AD} =0.2μs				
		4.5V	V _{REF} =AV _{DD} =V _{DD} , t _{AD} =6.4μs				
		5.5V	V _{REF} =AV _{DD} =V _{DD} , t _{AD} =6.4μs				
		4.5V	V _{REF} =AV _{DD} =V _{DD} , t _{AD} =12.8μs				
		5.5V	V _{REF} =AV _{DD} =V _{DD} , t _{AD} =12.8μs				
INL	A/D Integral Non-linearity	4.5V	V _{REF} =AV _{DD} =V _{DD} , t _{AD} =0.2μs	-4	—	4	LSB
		5.5V	V _{REF} =AV _{DD} =V _{DD} , t _{AD} =0.2μs				
		4.5V	V _{REF} =AV _{DD} =V _{DD} , t _{AD} =6.4μs				
		5.5V	V _{REF} =AV _{DD} =V _{DD} , t _{AD} =6.4μs				
		4.5V	V _{REF} =AV _{DD} =V _{DD} , t _{AD} =12.8μs				
		5.5V	V _{REF} =AV _{DD} =V _{DD} , t _{AD} =12.8μs				
G _{err}	Gain Error	—	—	—	—	±2	LSB
T _{adck}	ADCLK Period	—	—	—	0.2	—	μs
T _{ckh}	ADCLK High Width	—	—	—	83	—	ns
T _{ckl}	ADCLK Low Width	—	—	—	83	—	ns
T _{st1}	Setup Time for ADON	—	—	2	—	—	ns
T _{st2}	Setup Time for START latch	—	—	2	—	—	ns
T _{sth}	START High Width	—	—	25	—	—	ns
T _{deoc}	EOCB Output Delay	—	AV _{DD} =5V	—	3	—	ns
T _{dout}	Output Delay	—	AV _{DD} =5V	—	3	—	ns
T _{on}	ADC Wake Up Time	—	—	2	—	—	μs
T _{off}	ADC Sleep Time	—	—	—	—	5	ns

D/A Converter Characteristics

Ta=25°C

Symbol	Parameter	Test Conditions		Min.	Typ.	Max.	Unit
		V _{DD}	Conditions				
V _{DD}	D/A Operating Current	—	—	V _{LVR}	—	5.5	V
V _{DA}	D/A Output Voltage	—	00h ~ FFh, no load	0.01	—	0.99	V _{DD}
t _{DAC}	D/A Conversion Time	—	V _{DD} =5V, C _L =10pF	—	—	2	μs
R _o	D/A Output Resistance	—	—	—	10	—	kΩ

8-bit R-2R D/A Converter (Analog Conditon $V_{DD}=5V$, $C_L=10pF$)

Model Corner	TT	SF	FS	SS	FF
Temperature	25°C	25°C	25°C	90°C	-40°C
Operating Average Current ($V_{DD}=5V$, $C_L=10pF$)	352μA	330μA	374μA	297μA	413μA
Analog Output 00000000 (B) ~11111111 (B)	0~4.98V	0~4.981V	0~4.98V	0~4.98V	0~4.981V
Conversion Time	≤2μs	≤2μs	≤2μs	≤2μs	≤2μs

Operational Amplifier Characteristics

Ta=25°C

Symbol	Parameter	Test Conditions		Min.	Typ.	Max.	Unit
		V _{DD}	Conditions				
V _{OPR1}	Operating Voltage	3.3V	—	2.7	3.3	5.5	V
I _{OFF1}	Power Down Current	3.3V	—	—	—	0.1	μA
V _{OPOS1}	Input Offset Voltage	3.3V	Without calibration, AOF[4:0]=10000B	-15	—	+15	mV
V _{OPOS2}	Input Offset Voltage	3.3V	By calibration	-2	—	+2	mV
V _{CM}	Common Mode Voltage Range	3.3V	—	V _{SS}	—	V _{DD} -1.4V	V
PSRR	Power Supply Rejection Ratio	3.3V	—	90	—	96	dB
CMRR	Common Mode Rejection Ratio	3.3V	V _{CM} =0~V _{DD} -1.4V	—	106	—	dB
SR	Slew Rate+, Slew Rate-	3.3V	R _L =600Ω, C _L =100pF	1.29	2.18	2.5	V/μs
GBW	Gain Band Width	3.3V	R _L =600Ω, C _L =100pF	2.05	3.70	7.16	MHz
A _{OL}	Open Loop Gain	3.3V	R _L =600Ω, C _L =100pF	—	96	—	dB
PM	Phase Margin	3.3V	R _L =600Ω, C _L =100pF	—	90	—	—

Symbol	Parameter	Test Conditions		Min.	Typ.	Max.	Unit
		V _{DD}	Conditions				
V _{OPR1}	Operating Voltage	5V	—	2.7	3.3	5.5	V
I _{OFF1}	Power Down Current	5V	—	—	—	0.1	μA
V _{OPOS1}	Input Offset Voltage	5V	Without calibration, AOF[4:0]=10000B	-15	—	+15	mV
V _{OPOS2}	Input Offset Voltage	5V	By calibration	-2	—	+2	mV
V _{CM}	Common Mode Voltage Range	5V	—	V _{SS}	—	V _{DD} -1.4V	V
PSRR	Power Supply Rejection Ratio	5V	—	TBD	TBD	TBD	dB
CMRR	Common Mode Rejection Ratio	5V	V _{CM} =0 ~ V _{DD} -1.4V	TBD	TBD	TBD	dB
SR	Slew Rate+, Slew Rate-	5V	R _L =600Ω, C _L =100pF	TBD	TBD	TBD	V/μs
GBW	Gain Band Width	5V	R _L =600Ω, C _L =100pF	TBD	TBD	TBD	MHz
A _{OL}	Open Loop Gain	5V	R _L =600Ω, C _L =100pF	TBD	TBD	TBD	dB
PM	Phase Margin	5V	R _L =600Ω, C _L =100pF	TBD	TBD	TBD	—

Comparator Electrical Characteristics

Ta=25°C

Symbol	Parameter	Test Conditions		Min.	Typ.	Max.	Unit
		V _{DD}	Condition				
V _{CMP}	Comparator Operating Voltage	5V	—	2.2	5.0	5.5	V
I _{CMP}	Comparator Operating Current	5V	—	—	300	450	μA
I _{OFF}	Comparator Power Down Current	5V	Comparator disable	—	—	0.1	μA
V _{CMPOS}	Comparator Input Offset Voltage	5V	—	-10	—	+10	mV
V _{HYS0}	Hysteresis Width	5V	Comparator 0	TBC	100	TBC	mV
V _{HYS1}	Hysteresis Width	5V	Comparator 1,2,3	20	40	60	mV
V _{CM}	Input Common Mode Voltage Range	—	—	V _{SS}	—	V _{DD} -1.4	V
A _{OL}	Comparator Open Loop Gain	—	—	100	120	—	dB
t _{PD1}	Comparator Response Time	5V	V _M = 0~(V _{DD} -1.4)V With 10mV overdrive	—	—	1	μs
t _{PD2}	Comparator Response Time	5V	*With 100mV overdrive (note)	—	—	200	ns

*Note: Measured with comparator one input pin at V_M = (V_{DD}-1.4)/2 while the other pin input transition from V_{SS} to (V_M +100mV) or from V_{DD} to (V_M -100mV).

Power on Reset Electrical Characteristics

Ta=25°C

Symbol	Parameter	Test Conditions		Min.	Typ.	Max.	Unit
		V _{DD}	Condition				
V _{POR}	V _{DD} Start Voltage to Ensure Power-on Reset	—	—	—	—	100	mV
RR _{VDD}	V _{DD} Rise Rate to Ensure Power-on Reset	—	—	0.035	—	—	V/ms
t _{POR}	Minimum Time for V _{DD} to remain at V _{POR} to Ensure Power-on Reset	—	—	1	—	—	ms

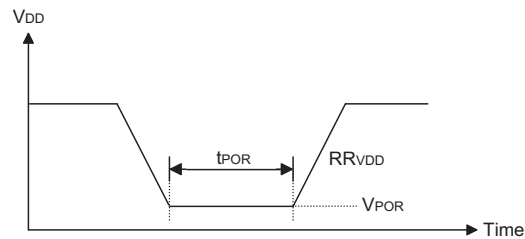

System Architecture

A key factor in the high-performance features of the Holtek range of microcontrollers is attributed to their internal system architecture. The device takes advantage of the usual features found within RISC microcontrollers providing increased speed of operation and Periodic performance. The pipelining scheme is implemented in such a way that instruction fetching and instruction execution are overlapped, hence instructions are effectively executed in one cycle, with the exception of branch or call instructions. An 8-bit wide ALU is used in practically all instruction set operations, which carries out arithmetic operations, logic operations, rotation, increment, decrement, branch decisions, etc. The internal data path is simplified by moving data through the Accumulator and the ALU. Certain internal registers are implemented in the Data Memory and can be directly or indirectly addressed. The simple addressing methods of these registers along with additional architectural features ensure that a minimum of external components is required to provide a functional I/O and A/D control system with maximum reliability and flexibility. This makes the device suitable for low-cost, high-volume production for controller applications.

Clocking and Pipelining

The main system clock, derived from either an HIRC or LIRC oscillator is subdivided into four internally generated non-overlapping clocks, T1~T4. The Program Counter is incremented at the beginning of the T1 clock during which time a new instruction is fetched. The remaining T2~T4 clocks carry out the decoding and execution functions. In this way, one T1~T4 clock cycle forms one instruction cycle. Although the fetching and execution of instructions takes place in consecutive instruction cycles, the pipelining structure of the microcontroller ensures that instructions are effectively executed in one instruction cycle. The exception to this are instructions where the contents of the Program Counter are changed, such as subroutine calls or jumps, in which case the instruction will take one more instruction cycle to execute.

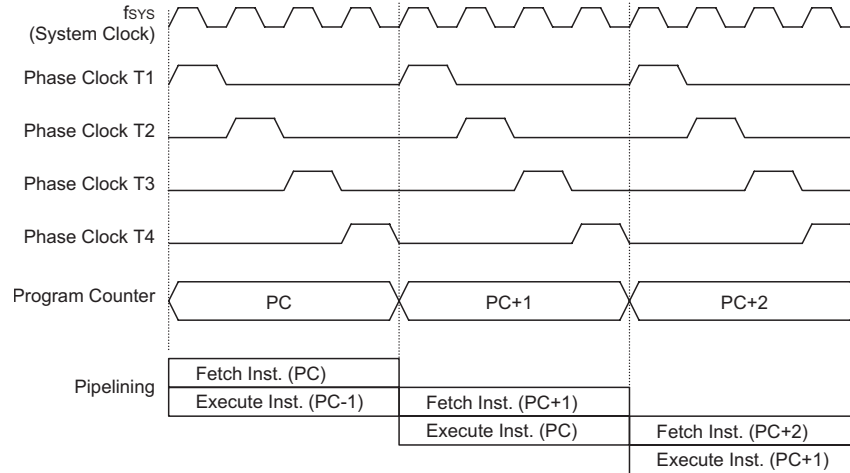

System Clock and Pipelining

For instructions involving branches, such as jump or call instructions, two machine cycles are required to complete instruction execution. An extra cycle is required as the program takes one cycle to first obtain the actual jump or call address and then another cycle to actually execute the branch. The requirement for this extra cycle should be taken into account by programmers in timing sensitive applications.

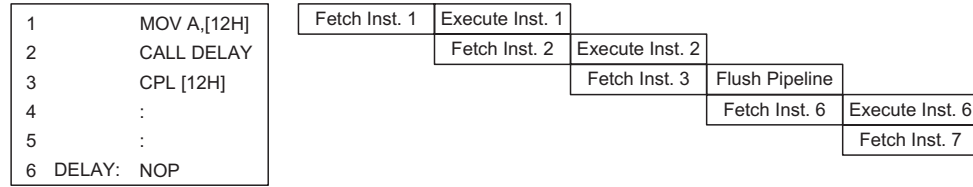

Instruction Fetching

Program Counter

During program execution, the Program Counter is used to keep track of the address of the next instruction to be executed. It is automatically incremented by one each time an instruction is executed except for instructions, such as "JMP" or "CALL" that demand a jump to a non-consecutive Program Memory address. Only the lower 8 bits, known as the Program Counter Low Register, are directly addressable by the application program.

When executing instructions requiring jumps to non-consecutive addresses such as a jump instruction, a subroutine call, interrupt or reset, etc., the microcontroller manages program control by loading the required address into the Program Counter. For conditional skip instructions, once the condition has been met, the next instruction, which has already been fetched during the present instruction execution, is discarded and a dummy cycle takes its place while the correct instruction is obtained.

Program Counter	
Program Counter High byte	PCL Register
PC10~PC8	PCL7~PCL0

The lower byte of the Program Counter, known as the Program Counter Low register or PCL, is available for program control and is a readable and writeable register. By transferring data directly into this register, a short program jump can be executed directly, however, as only this low byte is available for manipulation, the jumps are limited to the present page of memory, that is 256 locations. When such program jumps are executed it should also be noted that a dummy cycle will be inserted. Manipulating the PCL register may cause program branching, so an extra cycle is needed to pre-fetch.

Stack

This is a special part of the memory which is used to save the contents of the Program Counter only. The stack is neither part of the data nor part of the program space, and is neither readable nor writeable. The activated level is indexed by the Stack Pointer, and is neither readable nor writeable. At a subroutine call or interrupt acknowledge signal, the contents of the Program Counter are pushed onto the stack. At the end of a subroutine or an interrupt routine, signaled by a return instruction, RET or RETI, the Program Counter is restored to its previous value from the stack. After a device reset, the Stack Pointer will point to the top of the stack.

If the stack is full and an enabled interrupt takes place, the interrupt request flag will be recorded but the acknowledge signal will be inhibited. When the Stack Pointer is decremented, by RET or RETI, the interrupt will be serviced. This feature prevents stack overflow allowing the programmer to use the structure more easily. However, when the stack is full, a CALL subroutine instruction can still be executed which will result in a stack overflow. Precautions should be taken to avoid such cases which might cause unpredictable program branching. If the stack is overflow, the first Program Counter save in the stack will be lost.

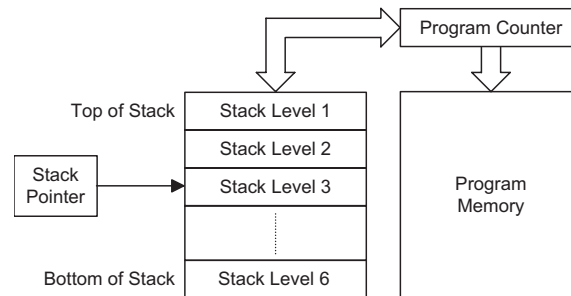

Arithmetic and Logic Unit – ALU

The arithmetic-logic unit or ALU is a critical area of the microcontroller that carries out arithmetic and logic operations of the instruction set. Connected to the main microcontroller data bus, the ALU receives related instruction codes and performs the required arithmetic or logical operations after which the result will be placed in the specified register. As these ALU calculation or operations may result in carry, borrow or other status changes, the status register will be correspondingly updated to reflect these changes. The ALU supports the following functions:

- Arithmetic operations: ADD, ADDM, ADC, ADCM, SUB, SUBM, SBC, SBCM, DAA
- Logic operations: AND, OR, XOR, ANDM, ORM, XORM, CPL, CPLA
- Rotation RRA, RR, RRCA, RRC, RLA, RL, RLCA, RLC
- Increment and Decrement INCA, INC, DECA, DEC
- Branch decision, JMP, SZ, SZA, SNZ, SIZ, SDZ, SIZA, SDZA, CALL, RET, RETI

Flash Program Memory

The Program Memory is the location where the user code or program is stored. For this device the Program Memory is Flash type, which means it can be programmed and re-programmed a large number of times, allowing the user the convenience of code modification on the same device. By using the appropriate programming tools, this Flash device offers users the flexibility to conveniently debug and develop their applications while also offering a means of field programming and updating.

Structure

The Program Memory has a capacity of $2K \times 16$ bits. The Program Memory is addressed by the Program Counter and also contains data, table information and interrupt entries. Table data, which can be setup in any location within the Program Memory, is addressed by a separate table pointer register.

Special Vectors

Within the Program Memory, certain locations are reserved for the reset and interrupts. The location 000H is reserved for use by the device reset for program initialisation. After a device reset is initiated, the program will jump to this location and begin execution.

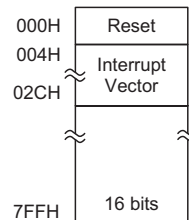

Program Memory Structure

Look-up Table

Any location within the Program Memory can be defined as a look-up table where programmers can store fixed data. To use the look-up table, the table pointer must first be setup by placing the address of the look up data to be retrieved in the table pointer register, TBLP and TBHP. These registers define the total address of the look-up table.

After setting up the table pointer, the table data can be retrieved from the Program Memory using the "TABRDC[m]" or "TABRDL[m]" instructions, respectively. When the instruction is executed, the lower order table byte from the Program Memory will be transferred to the user defined Data Memory register [m] as specified in the instruction. The higher order table data byte from the Program Memory will be transferred to the TBLH special register. Any unused bits in this transferred higher order byte will be read as "0".

The accompanying diagram illustrates the addressing data flow of the look-up table.

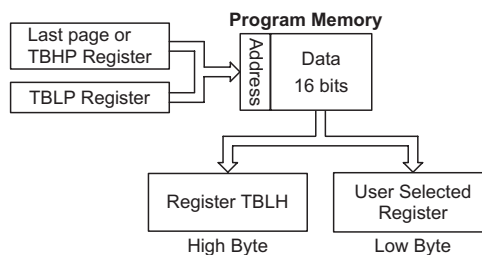

Instruction	Table Location Bits										
	b10	b9	b8	b7	b6	b5	b4	b3	b2	b1	b0
TABRDC [m]	@10	@9	@8	@7	@6	@5	@4	@3	@2	@1	@0
TABRDL [m]	1	1	1	@7	@6	@5	@4	@3	@2	@1	@0

Table Location

Note: b10~b0: Table location bits
 @7~@0: Table pointer (TBLP) bits
 @10~@8: Table pointer (TBHP) bits

Table Program Example

The following example shows how the table pointer and table data is defined and retrieved from the microcontroller. This example uses raw table data located in the Program Memory which is stored there using the ORG statement. The value at this ORG statement is "700H" which refers to the start address of the last page within the 2K words Program Memory of the device. The table pointer is setup here to have an initial value of "06H". This will ensure that the first data read from the data table will be at the Program Memory address "706H" or 6 locations after the start of the last page. Note that the value for the table pointer is referenced to the first address of the present page if the "TABRDC [m]" instruction is being used. The high byte of the table data which in this case is equal to zero will be transferred to the TBLH register automatically when the "TABRDC [m]" instruction is executed.

Because the TBLH register is a read-only register and cannot be restored, care should be taken to ensure its protection if both the main routine and Interrupt Service Routine use table read instructions. If using the table read instructions, the Interrupt Service Routines may change the value of the TBLH and subsequently cause errors if used again by the main routine. As a rule it is recommended that simultaneous use of the table read instructions should be avoided. However, in situations where simultaneous use cannot be avoided, the interrupts should be disabled prior to the execution of any main routine table-read instructions. Note that all table related instructions require two instruction cycles to complete their operation.

Table Read Program Example

```

tempreg1 db ?      ; temporary register #1
tempreg2 db ?      ; temporary register #2
:
:
mov a,06h          ; initialise low table pointer - note that this address is referenced
mov tblp,a
mov a,07h          ; initialise high table pointer
mov tbhp,a
:
:
tabrdc tempreg1    ; transfers value in table referenced by table pointer data at program
                  ; memory address "706H" transferred to tempreg1 and TBLH
dec tblp           ; reduce value of table pointer by one
tabrdc tempreg2    ; transfers value in table referenced by table pointer data at program
                  ; memory address "705H" transferred to tempreg2 and TBLH in this
                  ; example the data "1AH" is transferred to tempreg1 and data "0FH" to
                  ; register tempreg2
:
:
org 700h           ; sets initial address of program memory
dc 00Ah, 00Bh, 00Ch, 00Dh, 00Eh, 00Fh, 01Ah, 01Bh
:
:

```

In Circuit Programming

The provision of Flash type Program Memory provides the user with a means of convenient and easy upgrades and modifications to their programs on the same device. As an additional convenience, Holtek has provided a means of programming the microcontroller in-circuit using a 4-pin interface. This provides manufacturers with the possibility of manufacturing their circuit boards complete with a programmed or un-programmed microcontroller, and then programming or upgrading the program at a later stage. This enables product manufacturers to easily keep their manufactured products supplied with the latest program releases without removal and re-insertion of the device.

The Holtek Flash MCU to Writer Programming Pin correspondence table is as follows:

Holtek Write Pins	MCU Programming Pins	Function
ICPDA	PA0	Programming Serial Data/Address
ICPCK	PA2	Programming Serial Clock
VDD	VDD	Power Supply
VSS	VSS	Ground

During the programming process, the user must there take care to ensure that no other outputs are connected to these two pins. The Program Memory and EEPROM data memory can both be programmed serially in-circuit using this 4-wire interface. Data is downloaded and uploaded serially on a single pin with an additional line for the clock. Two additional lines are required for the power supply. The technical details regarding the in-circuit programming of the device are beyond the scope of this document and will be supplied in supplementary literature.

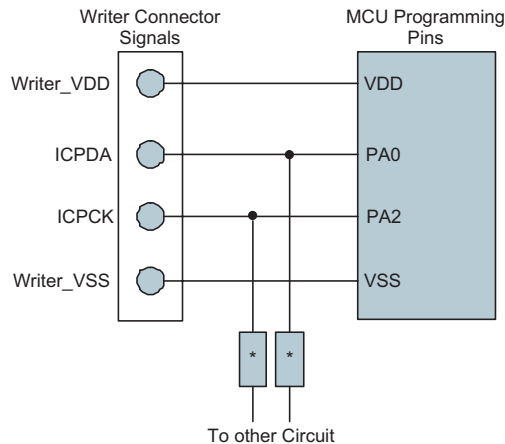

Note: * may be resistor or capacitor. The resistance of * must be greater than 1k or the capacitance of * must be less than 1nF.

On-Chip Debug Support – OCDS

An EV chip exists for the purposes of device emulation. This EV chip device also provides an "On-Chip Debug" function to debug the device during the development process. The EV chip and the actual MCU devices are almost functionally compatible except for the "On-Chip Debug" function. Users can use the EV chip device to emulate the real chip device behavior by connecting the OCSDSA and OCDSCK pins to the Holtek HT-IDE development tools. The OCSDSA pin is the OCDS Data/Address input/output pin while the OCDSCK pin is the OCDS clock input pin. When users use the EV chip for debugging, other functions which are shared with the OCSDSA and OCDSCK pins in the actual MCU device will have no effect in the EV chip. However, the two OCDS pins which are pin-shared with the ICP programming pins are still used as the Flash Memory programming pins for ICP. For a more detailed OCDS description, refer to the corresponding document named "Holtek e-Link for 8-bit MCU OCDS User's Guide".

Holtek e-Link Pins	EV Chip Pins	Pin Description
OCSDSA	OCSDSA	On-chip Debug Support Data/Address input/output
OCDSCK	OCDSCK	On-chip Debug Support Clock input
VDD	VDD	Power Supply
GND	VSS	Ground

RAM Data Memory

The Data Memory is a volatile area of 8-bit wide RAM internal memory and is the location where temporary information is stored. The RAM Data Memory capacity is up to 256×8 bits.

Structure

Divided into two sections, the first of these is an area of RAM, known as the Special Function Data Memory. Here are located registers which are necessary for correct operation of the device. Many of these registers can be read from and written to directly under program control, however, some remain protected from user manipulation. The second area of Data Memory is known as the General Purpose Data Memory, which is reserved for general purpose use. All locations within this area are read and write accessible under program control.

The overall Data Memory is subdivided into two banks. The Special Purpose Data Memory registers are accessible in all banks, with the exception of the EEC register at address 40H, which is only accessible in Bank 1. Switching between the different Data Memory banks is achieved by setting the Bank Pointer to the correct value. The start address of the Data Memory for the device is the address 00H.

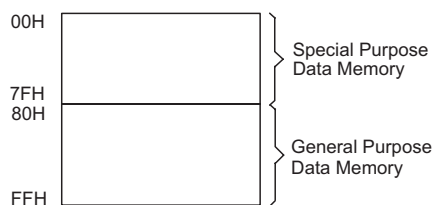

HT66FM5230
Data Memory Structure

Bank 0, 1		Bank 0	Bank 1
00H	IAR0	40H	Unused EEC
01H	MP0	41H	EEA
02H	IAR1	42H	EED
03H	MP1	43H	ADRL
04H	BP	44H	ADRH
05H	ACC	45H	ADCR0
06H	PCL	46H	ADCR1
07H	TBLP	47H	ADCR2
08H	TBLH	48H	Unused
09H	TBHP	49H	ADDL
0AH	STATUS	4AH	ADLVDL
0BH	SMOD	4BH	ADLVDH
0CH	LVDC	4CH	ADHVDL
0DH	LVRC	4DH	ADHVDH
0EH	WDTC	4EH	PWMC
0FH	TBC	4FH	DUTR0L
10H	INTC0	50H	DUTR0H
11H	INTC1	51H	PRDRL
12H	INTC2	52H	PRDRH
13H	MFI4	53H	PWMRL
14H	MFI0	54H	PWMRH
15H	MFI1	55H	MCF
16H	MFI2	56H	MCD
17H	MFI3	57H	DTS
18H	PAWU	58H	PLC
19H	PAPU	59H	HDCR
1AH	PA	5AH	HDCD
1BH	PAC	5BH	HDCT0
1CH	PBPU	5CH	HDCT1
1DH	PB	5DH	HDCT2
1EH	PBC	5EH	HDCT3
1FH	PCPU	5FH	HDCT4
20H	PC	60H	HDCT5
21H	PCC	61H	HDCT6
22H	DUTR2L	62H	HDCT7
23H	DUTR2H	63H	HDCT8
24H	INTEG	64H	HDCT9
25H	IICC0	65H	HDCT10
26H	IICC1	66H	HDCT11
27H	IICD	67H	MPTC1
28H	IICA	68H	MPTC2
29H	I2CTOC	69H	TM1C0
2AH	NF_VIH	6AH	TM1C1
2BH	NF_VIL	6BH	TM1DL
2CH	DUTR1L	6CH	TM1DH
2DH	DUTR1H	6DH	TM1AL
2EH	Unused	6EH	TM1AH
2FH	HCHK_NUM	6FH	TM1RP
30H	HNF_MSEL	70H	OPACAL
31H	CAPTC0	71H	PWMME
32H	CAPTC1	72H	PWMMD
33H	CAPTMDL	73H	TM0C0
34H	CAPTMDH	74H	TM0C1
35H	CAPTMAL	75H	TM0DL
36H	CAPTMAH	76H	TM0DH
37H	CAPTACL	77H	TM0AL
38H	CAPTACH	78H	TM0AH
39H	OPOMS	79H	Unused
3AH	OPCM	7AH	TM2C0 PAPS0
3BH	CPC	7BH	TM2C1 PAPS1
3CH	Unused	7CH	TM2DL PBPS0
3DH	Unused	7DH	TM2DH PCPS0
3EH	Unused	7EH	TM2AL PCPS1
3FH	CTRL	7FH	TM2AH PRM

Special Purpose Data Memory Structure

Special Function Register Description

Most of the Special Function Register details will be described in the relevant functional section, however several registers require a separate description in this section.

Indirect Addressing Registers – IAR0, IAR1

The Indirect Addressing Registers, IAR0 and IAR1, although having their locations in normal RAM register space, do not actually physically exist as normal registers. The method of indirect addressing for RAM data manipulation uses these Indirect Addressing Registers and Memory Pointers, in contrast to direct memory addressing, where the actual memory address is specified. Actions on the IAR0 and IAR1 registers will result in no actual read or write operation to these registers but rather to the memory location specified by their corresponding Memory Pointers, MP0 or MP1. Acting as a pair, IAR0 and MP0 can together access data from Bank 0 while the IAR1 and MP1 register pair can access data from any bank. As the Indirect Addressing Registers are not physically implemented, reading the Indirect Addressing Registers indirectly will return a result of "00H" and writing to the registers indirectly will result in no operation.

Memory Pointers – MP0, MP1

Two Memory Pointers, known as MP0 and MP1 are provided. These Memory Pointers are physically implemented in the Data Memory and can be manipulated in the same way as normal registers providing a convenient way with which to address and track data. When any operation to the relevant Indirect Addressing Registers is carried out, the actual address that the microcontroller is directed to is the address specified by the related Memory Pointer. MP0, together with Indirect Addressing Register, IAR0, are used to access data from Bank 0, while MP1 and IAR1 are used to access data from all banks according to BP register. Direct Addressing can only be used with Bank 0, all other Banks must be addressed indirectly using MP1 and IAR1.

The following example shows how to clear a section of four Data Memory locations already defined as locations `adres1` to `adres4`.

Indirect Addressing Program Example

```
data .section 'data'
adres1 db ?
adres2 db ?
adres3 db ?
adres4 db ?
block db ?
code .section at 0 'code'
org00h
start:
    mov a,04h          ; setup size of block
    mov block,a
    mov a,offset adres1 ; Accumulator loaded with first RAM address
    mov mp0,a         ; setup memory pointer with first RAM address
loop:
    clr IAR0          ; clear the data at address defined by mp0
    inc mp0           ; increment memory pointer
    sdz block         ; check if last memory location has been cleared
    jmp loop
continue:
```

The important point to note here is that in the example shown above, no reference is made to specific Data Memory addresses.

Bank Pointer – BP

For this device, the Data Memory is divided into two banks, Bank0 and Bank1. Selecting the required Data Memory area is achieved using the Bank Pointer. Bit 0 of the Bank Pointer is used to select Data Memory Banks 0~1.

The Data Memory is initialised to Bank 0 after a reset, except for a WDT time-out reset in the Power Down Mode, in which case, the Data Memory bank remains unaffected. It should be noted that the Special Function Data Memory is not affected by the bank selection, which means that the Special Function Registers can be accessed from within any bank. Directly addressing the Data Memory will always result in Bank 0 being accessed irrespective of the value of the Bank Pointer. Accessing data from Bank1 must be implemented using Indirect Addressing.

BP Register

Bit	7	6	5	4	3	2	1	0
Name	—	—	—	—	—	—	—	DMBP0
R/W	—	—	—	—	—	—	—	R/W
POR	—	—	—	—	—	—	—	0

Bit 7 ~ 1 Unimplemented, read as "0"

Bit 0 **DMBP0:** Select Data Memory Banks
 0: Bank 0
 1: Bank 1

Accumulator – ACC

The Accumulator is central to the operation of any microcontroller and is closely related with operations carried out by the ALU. The Accumulator is the place where all intermediate results from the ALU are stored. Without the Accumulator it would be necessary to write the result of each calculation or logical operation such as addition, subtraction, shift, etc., to the Data Memory resulting in higher programming and timing overheads. Data transfer operations usually involve the temporary storage function of the Accumulator; for example, when transferring data between one user-defined register and another, it is necessary to do this by passing the data through the Accumulator as no direct transfer between two registers is permitted.

Program Counter Low Register – PCL

To provide additional program control functions, the low byte of the Program Counter is made accessible to programmers by locating it within the Special Purpose area of the Data Memory. By manipulating this register, direct jumps to other program locations are easily implemented. Loading a value directly into this PCL register will cause a jump to the specified Program Memory location, however, as the register is only 8-bit wide, only jumps within the current Program Memory page are permitted. When such operations are used, note that a dummy cycle will be inserted.

Look-up Table Registers – TBLP, TBHP, TBLH

These three special function registers are used to control operation of the look-up table which is stored in the Program Memory. TBLP and TBHP are the table pointers and indicate the location where the table data is located. Their value must be setup before any table read commands are executed. Their value can be changed, for example using the "INC" or "DEC" instructions, allowing for easy table data pointing and reading. TBLH is the location where the high order byte of the table data is stored after a table read data instruction has been executed. Note that the lower order table data byte is transferred to a user defined location.

Status Register – STATUS

This 8-bit register contains the zero flag (Z), carry flag (C), auxiliary carry flag (AC), overflow flag (OV), power down flag (PDF), and watchdog time-out flag (TO). These arithmetic/logical operation and system management flags are used to record the status and operation of the microcontroller.

With the exception of the TO and PDF flags, bits in the status register can be altered by instructions like most other registers. Any data written into the status register will not change the TO or PDF flag. In addition, operations related to the status register may give different results due to the different instruction operations. The TO flag can be affected only by a system power-up, a WDT time-out or by executing the "CLR WDT" or "HALT" instruction. The PDF flag is affected only by executing the "HALT" or "CLR WDT" instruction or during a system power-up.

The Z, OV, AC and C flags generally reflect the status of the latest operations.

- C is set if an operation results in a carry during an addition operation or if a borrow does not take place during a subtraction operation; otherwise C is cleared. C is also affected by a rotate through carry instruction.
- AC is set if an operation results in a carry out of the low nibbles in addition, or no borrow from the high nibble into the low nibble in subtraction; otherwise AC is cleared.
- Z is set if the result of an arithmetic or logical operation is zero; otherwise Z is cleared.
- OV is set if an operation results in a carry into the highest-order bit but not a carry out of the highest-order bit, or vice versa; otherwise OV is cleared.
- PDF is cleared by a system power-up or executing the "CLR WDT" instruction. PDF is set by executing the "HALT" instruction.
- TO is cleared by a system power-up or executing the "CLR WDT" or "HALT" instruction. TO is set by a WDT time-out.

In addition, on entering an interrupt sequence or executing a subroutine call, the status register will not be pushed onto the stack automatically. If the contents of the status registers are important and if the subroutine can corrupt the status register, precautions must be taken to correctly save it.

STATUS Register

Bit	7	6	5	4	3	2	1	0
Name	—	—	TO	PDF	OV	Z	AC	C
R/W	—	—	R	R	R/W	R/W	R/W	R/W
POR	—	—	0	0	x	x	x	x

"x" unknown

- Bit 7 ~ 6 **Unimplemented**, read as "0"
- Bit 5 **TO**: Watchdog Time-Out flag
 0: After power up or executing the "CLR WDT" or "HALT" instruction
 1: A watchdog time-out occurred.
- Bit 4 **PDF**: Power down flag
 0: After power up or executing the "CLR WDT" instruction
 1: By executing the "HALT" instruction
- Bit 3 **OV**: Overflow flag
 0: no overflow
 1: an operation results in a carry into the highest-order bit but not a carry out of the highest-order bit or vice versa.
- Bit 2 **Z**: Zero flag
 0: The result of an arithmetic or logical operation is not zero
 1: The result of an arithmetic or logical operation is zero
- Bit 1 **AC**: Auxiliary flag
 0: no auxiliary carry
 1: an operation results in a carry out of the low nibbles in addition, or no borrow from the high nibble into the low nibble in subtraction
- Bit 0 **C**: Carry flag
 0: no carry-out
 1: an operation results in a carry during an addition operation or if a borrow does not take place during a subtraction operation
 C is also affected by a rotate through carry instruction.

EEPROM Data Memory

One of the special features in the device is its internal EEPROM Data Memory. EEPROM, which stands for Electrically Erasable Programmable Read Only Memory, is by its nature a non-volatile form of memory, with data retention even when its power supply is removed. By incorporating this kind of data memory, a whole new host of application possibilities are made available to the designer. The availability of EEPROM storage allows information such as product identification numbers, calibration values, specific user data, system setup data or other product information to be stored directly within the product microcontroller. The process of reading and writing data to the EEPROM memory has been reduced to a very trivial affair.

EEPROM Data Memory Structure

The EEPROM Data Memory capacity is up to 32×8 bits. Unlike the Program Memory and RAM Data Memory, the EEPROM Data Memory is not directly mapped and is therefore not directly accessible in the same way as the other types of memory. Read and Write operations to the EEPROM are carried out in single byte operations using an address and data register in Bank 0 and a single control register in Bank 1.

EEPROM Registers

Three registers control the overall operation of the internal EEPROM Data Memory. These are the address register, EEA, the data register, EED and a single control register, EEC. As both the EEA and EED registers are located in Bank 0, they can be directly accessed in the same way as any other Special Function Register. The EEC register however, being located in Bank1, cannot be directly addressed directly and can only be read from or written to indirectly using the MP1 Memory Pointer and Indirect Addressing Register, IAR1. Because the EEC control register is located at address 40H in Bank 1, the MP1 Memory Pointer must first be set to the value 40H and the Bank Pointer register, BP, set to the value, 01H, before any operations on the EEC register are executed.

EEPROM Control Registers List

Name	Bit							
	7	6	5	4	3	2	1	0
EEA	—	—	—	D4	D3	D2	D1	D0
EED	D7	D6	D5	D4	D3	D2	D1	D0
EEC	—	—	—	—	WREN	WR	RDEN	RD

EEA Register

Bit	7	6	5	4	3	2	1	0
Name	—	—	—	D4	D3	D2	D1	D0
R/W	—	—	—	R/W	R/W	R/W	R/W	R/W
POR	—	—	—	0	0	0	0	0

- Bit 7 ~ 5 Unimplemented, read as "0"
- Bit 4 ~ 0 Data EEPROM address
Data EEPROM address bit 4 ~ bit 0

EED Register

Bit	7	6	5	4	3	2	1	0
Name	D7	D6	D5	D4	D3	D2	D1	D0
R/W	R/W	R/W	R/W	R/W	R/W	R/W	R/W	R/W
POR	0	0	0	0	0	0	0	0

Bit 7 ~ 0 Data EEPROM data
Data EEPROM data bit 7 ~ bit 0

EEC Register

Bit	7	6	5	4	3	2	1	0
Name	—	—	—	—	WREN	WR	RDEN	RD
R/W	—	—	—	—	R/W	R/W	R/W	R/W
POR	—	—	—	—	0	0	0	0

Bit 7 ~ 4 Unimplemented, read as "0"

Bit 3 **WREN:** Data EEPROM Write Enable
0: Disable
1: Enable

This is the Data EEPROM Write Enable Bit which must be set high before Data EEPROM write operations are carried out. Clearing this bit to zero will inhibit Data EEPROM write operations.

Bit 2 **WR:** EEPROM Write Control
0: Write cycle has finished
1: Activate a write cycle

This is the Data EEPROM Write Control Bit and when set high by the application program will activate a write cycle. This bit will be automatically reset to zero by the hardware after the write cycle has finished. Setting this bit high will have no effect if the WREN has not first been set high.

Bit 1 **RDEN:** Data EEPROM Read Enable
0: Disable
1: Enable

This is the Data EEPROM Read Enable Bit which must be set high before Data EEPROM read operations are carried out. Clearing this bit to zero will inhibit Data EEPROM read operations.

Bit 0 **RD:** EEPROM Read Control
0: Read cycle has finished
1: Activate a read cycle

This is the Data EEPROM Read Control Bit and when set high by the application program will activate a read cycle. This bit will be automatically reset to zero by the hardware after the read cycle has finished. Setting this bit high will have no effect if the RDEN has not first been set high.

Note: The WREN, WR, RDEN and RD can not be set to "1" at the same time in one instruction.
The WR and RD can not be set to "1" at the same time.

Reading Data from the EEPROM

To read data from the EEPROM, the read enable bit, RDEN, in the EEC register must first be set high to enable the read function. The EEPROM address of the data to be read must then be placed in the EEA register. If the RD bit in the EEC register is now set high, a read cycle will be initiated. Setting the RD bit high will not initiate a read operation if the RDEN bit has not been set. When the read cycle terminates, the RD bit will be automatically cleared to zero, after which the data can be read from the EED register. The data will remain in the EED register until another read or write operation is executed. The application program can poll the RD bit to determine when the data is valid for reading.

Writing Data to the EEPROM

To write data to the EEPROM, the write enable bit, WREN, in the EEC register must first be set high to enable the write function. The EEPROM address of the data to be written must then be placed in the EEA register and the data placed in the EED register. If the WR bit in the EEC register is now set high, an internal write cycle will then be initiated. Setting the WR bit high will not initiate a write cycle if the WREN bit has not been set. As the EEPROM write cycle is controlled using an internal timer whose operation is asynchronous to microcontroller system clock, a certain time will elapse before the data will have been written into the EEPROM. Detecting when the write cycle has finished can be implemented either by polling the WR bit in the EEC register or by using the EEPROM interrupt. When the write cycle terminates, the WR bit will be automatically cleared to zero by the microcontroller, informing the user that the data has been written to the EEPROM. The application program can therefore poll the WR bit to determine when the write cycle has ended.

Write Protection

Protection against inadvertent write operation is provided in several ways. After the device is powered-on the Write Enable bit in the control register will be cleared preventing any write operations. Also at power-on the Bank Pointer, BP, will be reset to zero, which means that Data Memory Bank 0 will be selected. As the EEPROM control register is located in Bank 1, this adds a further measure of protection against spurious write operations. During normal program operation, ensuring that the Write Enable bit in the control register is cleared will safeguard against incorrect write operations.

EEPROM Interrupt

The EEPROM write interrupt is generated when an EEPROM write cycle has ended. The EEPROM interrupt must first be enabled by setting the EPWE bit in the relevant interrupt register. When an EEPROM write cycle ends, the EPWF request flag will be set. If the global and EEPROM interrupts are enabled and the stack is not full, a jump to the associated Interrupt vector will take place. When the interrupt is serviced, the EEPROM interrupt flag will be automatically reset. More details can be obtained in the Interrupt section.

Programming Considerations

Care must be taken that data is not inadvertently written to the EEPROM. Protection can be Periodic by ensuring that the Write Enable bit is normally cleared to zero when not writing. Also the Bank Pointer could be normally cleared to zero as this would inhibit access to Bank 1 where the EEPROM control register exist. Although certainly not necessary, consideration might be given in the application program to the checking of the validity of new write data by a simple read back process. When writing data the WR bit must be set high immediately after the WREN bit has been set high, to ensure the write cycle executes correctly. The global interrupt bit EMI should also be cleared before a write cycle is executed and then re-enabled after the write cycle starts.

Programming Examples**Reading data from the EEPROM - polling method**

```
MOV A, EEPROM_ADRES      ; user defined address
MOV EEA, A
MOV A, 040H              ; setup memory pointer MP1
MOV MP1, A               ; MP1 points to EEC register
MOV A, 01H               ; setup Bank Pointer
MOV BP, A
SET IAR1.1               ; set RDEN bit, enable read operations
SET IAR1.0               ; start Read Cycle - set RD bit
BACK:
SZ IAR1.0                ; check for read cycle end
JMP BACK
CLR IAR1                 ; disable EEPROM write
CLR BP
MOV A, EED               ; move read data to register
MOV READ_DATA, A
```

Writing Data to the EEPROM - polling method

```
CLR EMI
MOV A, EEPROM_ADRES      ; user defined address
MOV EEA, A
MOV A, EEPROM_DATA       ; user defined data
MOV EED, A
MOV A, 040H              ; setup memory pointer MP1
MOV MP1, A               ; MP1 points to EEC register
MOV A, 01H               ; setup Bank Pointer
MOV BP, A
SET IAR1.3               ; set WREN bit, enable write operations
SET IAR1.2               ; start Write Cycle - set WR bit
SET EMI
BACK:
SZ IAR1.2                ; check for write cycle end
JMP BACK
CLR IAR1                 ; disable EEPROM write
CLR BP
```

Oscillator

Various oscillator options offer the user a wide range of functions according to their various application requirements. The flexible features of the oscillator functions ensure that the best optimisation can be achieved in terms of speed and power saving. Oscillator selections and operation are selected through registers.

Oscillator Overview

In addition to being the source of the main system clock the oscillators also provide clock sources for the Watchdog Timer and Time Base Interrupts. Fully integrated internal oscillators, requiring no external components, are provided to form a wide range of both fast and slow system oscillators. The higher frequency oscillators provide higher performance but carry with it the disadvantage of higher power requirements, while the opposite is of course true for the lower frequency oscillators. With the capability of dynamically switching between fast and slow system clock, the device has the flexibility to optimize the performance/power ratio, a feature especially important in power sensitive portable applications.

Type	Name	Freq.
Internal High Speed RC	HIRC	20MHz
Internal Low Speed RC	LIRC	32kHz

Oscillator Types

System Clock Configurations

There are two methods of generating the system clock, a high speed oscillator and a low speed oscillator. The high speed oscillator is the internal 20MHz RC oscillator. The low speed oscillator is the internal 32kHz (LIRC) oscillator. Selecting whether the low or high speed oscillator is used as the system oscillator is implemented using the HLCLK bit and CKS2 ~ CKS0 bits in the SMOD register and as the system clock can be dynamically selected.

The actual source clock used for the high speed and the low speed oscillators is chosen via registers. The frequency of the slow speed or high speed system clock is also determined using the HLCLK bit and CKS2 ~ CKS0 bits in the SMOD register. Note that two oscillator selections must be made namely one high speed and one low speed system oscillators. It is not possible to choose a no-oscillator selection for either the high or low speed oscillator.

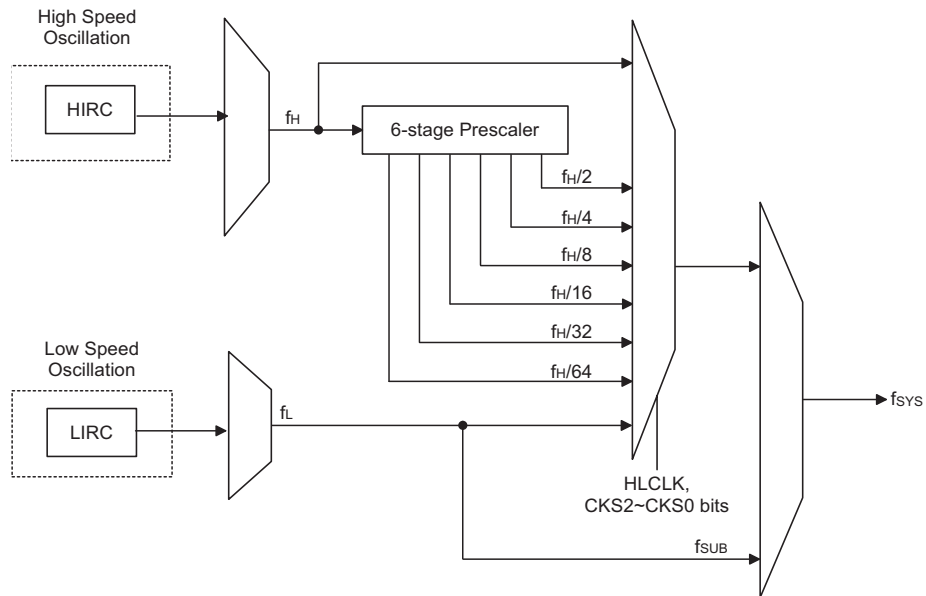

System Clock Configurations

Internal 20MHz RC Oscillator – HIRC

The internal RC oscillator is a fully integrated system oscillator requiring no external components. The internal RC oscillator has a fixed frequency of 20MHz. Device trimming during the manufacturing process and the inclusion of internal frequency compensation circuits are used to ensure that the influence of the power supply voltage, temperature and process variations on the oscillation frequency are minimised. As a result, at a power supply of 5V and at a temperature of 25°C degrees, the fixed oscillation frequency of 20MHz will have a tolerance within 2%.

Internal 32kHz Oscillator – LIRC

The Internal 32kHz System Oscillator is a low frequency oscillator choice. It is a fully integrated RC oscillator with a typical frequency of 32kHz at 5V, requiring no external components for its implementation. Device trimming during the manufacturing process and the inclusion of internal frequency compensation circuits are used to ensure that the influence of the power supply voltage, temperature and process variations on the oscillation frequency are minimised. As a result, at a power supply of 5V and at a temperature of 25°C degrees, the fixed oscillation frequency of 32kHz will have a tolerance within 10%.

Supplementary Clocks

The low speed oscillator, in addition to providing a system clock source are also used to provide a clock source to other device functions. These are the Watchdog Timer and the Time Base Interrupt.

Operating Modes and System Clocks

Present day applications require that their microcontrollers have high performance but often still demand that they consume as little power as possible, conflicting requirements that are especially true in battery powered portable applications. The fast clocks required for high performance will by their nature increase current consumption and of course vice-versa, lower speed clocks reduce current consumption. As Holtek has provided this device with both high and low speed clock sources and the means to switch between them dynamically, the user can optimise the operation of their microcontroller to achieve the best performance/power ratio.

System Clocks

The device has many different clock sources for both the CPU and peripheral function operation. By providing the user with a wide range of clock options using configuration options and register programming, a clock system can be configured to obtain maximum application performance.

The main system clock, can come from either a high frequency, f_H , or low frequency, f_L , source, and is selected using the HLCLK bit and CKS2~CKS0 bits in the SMOD register. The high speed system clock can be sourced from the HIRC oscillator. The low speed system clock source can be sourced from the LIRC oscillator. The other choice, which is a divided version of the high speed system oscillator has a range of $f_H/2 \sim f_H/64$.

There are two additional internal clocks for the peripheral circuits, the substitute clock, f_{SUB} , and the Time Base clock, f_{TBC} . Each of these internal clocks is sourced by the LIRC oscillator.

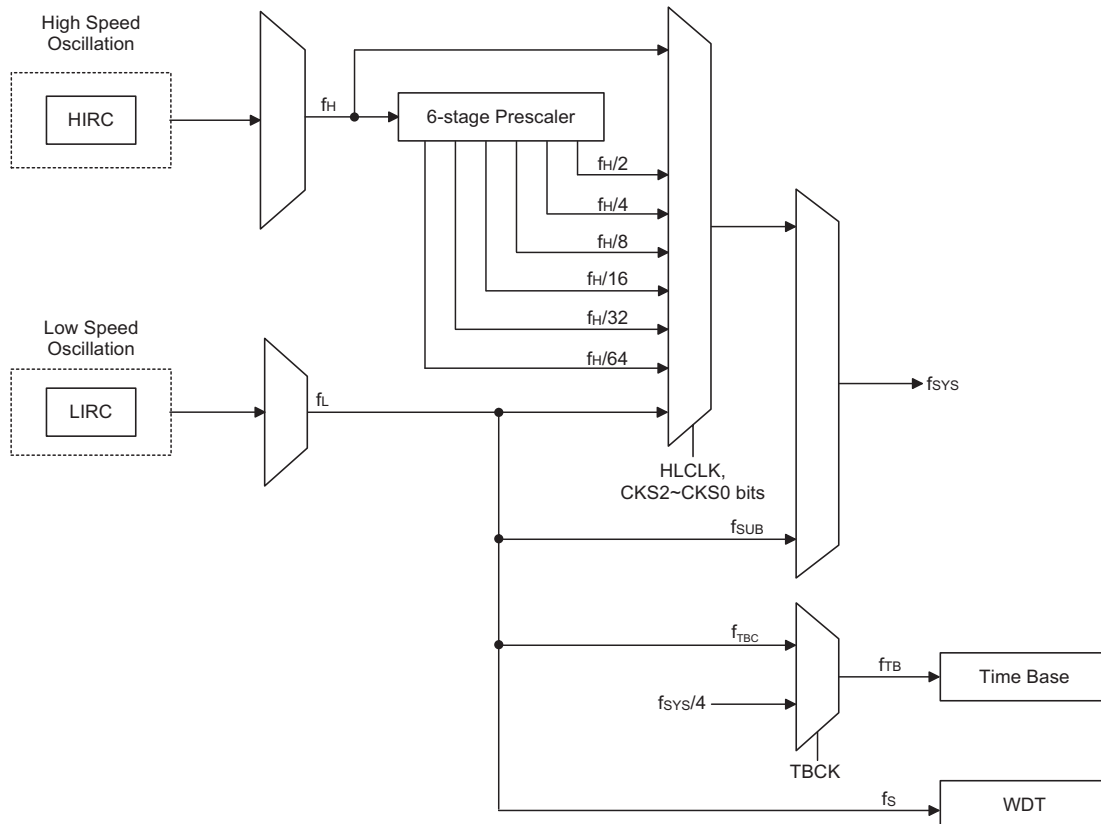

System Clock Configurations

Note: When the system clock source f_{SYS} is switched to f_L from f_H , the high speed oscillation will stop to conserve the power. Thus there is no $f_H \sim f_H/64$ for peripheral circuit to use.

System Operation Modes

There are five different modes of operation for the microcontroller, each one with its own special characteristics and which can be chosen according to the specific performance and power requirements of the application. There are two modes allowing normal operation of the microcontroller, the NORMAL Mode and SLOW Mode. The remaining three modes, the SLEEP, IDLE0 and IDLE1 Mode are used when the microcontroller CPU is switched off to conserve power.

Operating Mode	Description				
	CPU	f _{sys}	f _{sub}	f _s	f _{TBC}
NORMAL mode	On	f _H ~f _H /64	On	On	On
SLOW mode	On	f _L	On	On	On
IDLE0 mode	Off	Off	On	On	On
IDLE1 mode	Off	On	On	On	On
SLEEP mode	Off	Off	On	On	Off

NORMAL Mode

As the name suggests this is one of the main operating modes where the microcontroller has all of its functions operational and where the system clock is provided by the high speed oscillator. This mode operates allowing the microcontroller to operate normally with a clock source will come from the high speed oscillator, HIRC. The high speed oscillator will however first be divided by a ratio ranging from 1 to 64, the actual ratio being selected by the CKS2~CKS0 and HLCLK bits in the SMOD register. Although a high speed oscillator is used, running the microcontroller at a divided clock ratio reduces the operating current.

SLOW Mode

This is also a mode where the microcontroller operates normally although now with a slower speed clock source. The clock source used will be from f_L. Running the microcontroller in this mode allows it to run with much lower operating currents. In the SLOW Mode, the f_H is off.

SLEEP Mode

The SLEEP Mode is entered when an HALT instruction is executed and when the IDLEN bit in the SMOD register is low. In the SLEEP mode the CPU will be stopped. However the f_L clocks will continue to operate.

IDLE0 Mode

The IDLE0 Mode is entered when a HALT instruction is executed and when the IDLEN bit in the SMOD register is high and the FSYSOEN bit in the CTRL register is low. In the IDLE0 Mode the system oscillator will be inhibited from driving the CPU but some peripheral functions will remain operational such as the Watchdog Timer, TMs and IIC. In the IDLE0 Mode the system oscillator will be stopped, the Watchdog Timer clock, f_s, will be on.

IDLE1 Mode

The IDLE1 Mode is entered when a HALT instruction is executed and when the IDLEN bit in the SMOD register is high and the FSYSOEN bit in the CTRL register is high. In the IDLE1 Mode the system oscillator will be inhibited from driving the CPU but may continue to provide a clock source to keep some peripheral functions operational such as the Watchdog Timer and TMs. In the IDLE1 Mode the system oscillator will continue to run, and this system oscillator may be high speed or low speed system oscillator. In the IDLE1 Mode the low frequency clock f_s will be on.

Control Register

The SMOD register is used to control the internal clocks within the device.

SMOD Register

Bit	7	6	5	4	3	2	1	0
Name	CKS2	CKS1	CKS0	—	LTO	HTO	IDLEN	HLCLK
R/W	R/W	R/W	R/W	—	R	R	R/W	R/W
POR	0	0	0	—	0	0	1	1

Bit 7 ~ 5 **CKS2 ~ CKS0**: The system clock selection when HLCLK is "0"

000: f_L (f_{LIRC})
 001: f_L (f_{LIRC})
 010: $f_H/64$
 011: $f_H/32$
 100: $f_H/16$
 101: $f_H/8$
 110: $f_H/4$
 111: $f_H/2$

These three bits are used to select which clock is used as the system clock source. In addition to the system clock source, which can be LIRC, a divided version of the high speed system oscillator can also be chosen as the system clock source.

Bit 4 Unimplemented, read as "0".

Bit 3 **LTO**: LIRC System OSC SST ready flag

0: Not ready
 1: Ready

This is the low speed system oscillator SST ready flag which indicates when the low speed system oscillator is stable after power on reset or a wake-up has occurred. The flag will change to a high level after 1~2 cycles if the LIRC oscillator is used.

Bit 2 **HTO**: HIRC System OSC SST ready flag

0: Not ready
 1: Ready

This is the high speed system oscillator SST ready flag which indicates when the high speed system oscillator is stable after a wake-up has occurred. This flag is cleared to "0" by hardware when the device is powered on and then changes to a high level after the high speed system oscillator is stable. Therefore this flag will always be read as "1" by the application program after device power-on. The flag will be low when in the SLEEP or IDLE0 Mode but after power on reset or a wake-up has occurred, the flag will change to a high level after 15~16 clock cycles if the HIRC oscillator is used.

Bit 1 **IDLEN**: IDLE Mode Control

0: Disable
 1: Enable

This is the IDLE Mode Control bit and determines what happens when the HALT instruction is executed. If this bit is high, when a HALT instruction is executed the device will enter the IDLE Mode. In the IDLE1 Mode the CPU will stop running but the system clock will continue to keep the peripheral functions operational, if FSYSON bit is high. If FSYSON bit is low, the CPU and the system clock will all stop in IDLE0 mode. If the bit is low the device will enter the SLEEP Mode when a HALT instruction is executed.

Bit 0 **HLCLK**: System Clock Selection

0: $f_H/2 \sim f_H/64$ or f_L
 1: f_H

This bit is used to select if the f_H clock or the $f_H/2 \sim f_H/64$ or f_L clock is used as the system clock. When the bit is high the f_H clock will be selected and if low the $f_H/2 \sim f_H/64$ or f_L clock will be selected. When system clock switches from the f_H clock to the f_L clock and the f_H clock will be automatically switched off to conserve power.

CTRL Register

Bit	7	6	5	4	3	2	1	0
Name	FSYSON	—	—	—	—	LVRF	LRF	WRF
R/W	R/W	—	—	—	—	R/W	R/W	R/W
POR	0	—	—	—	—	×	0	0

- Bit 7 **FSYSON:** f_{SYS} Control in IDLE Mode
 0: Disable
 1: Enable
- Bit 6~3 Unimplemented, read as 0.
- Bit 2 **LVRF:** LVR function reset flag
 0: Not occur
 1: Occurred
 This bit is set to 1 when a specific Low Voltage Reset situation condition occurs. This bit can only be cleared to 0 by the application program.
- Bit 1 **LRF:** LVRC Control register software reset flag
 0: Not occur
 1: Occurred
 This bit is set to 1 if the LVRC register contains any non defined LVR voltage register values. This in effect acts like a software reset function. This bit can only be cleared to 0 by the application program.
- Bit 0 **WRF:** WDT Control register software reset flag
 0: Not occur
 1: Occurred
 This bit is set to 1 by the WDT Control register software reset and cleared by the application program. Note that this bit can only be cleared to 0 by the application program.

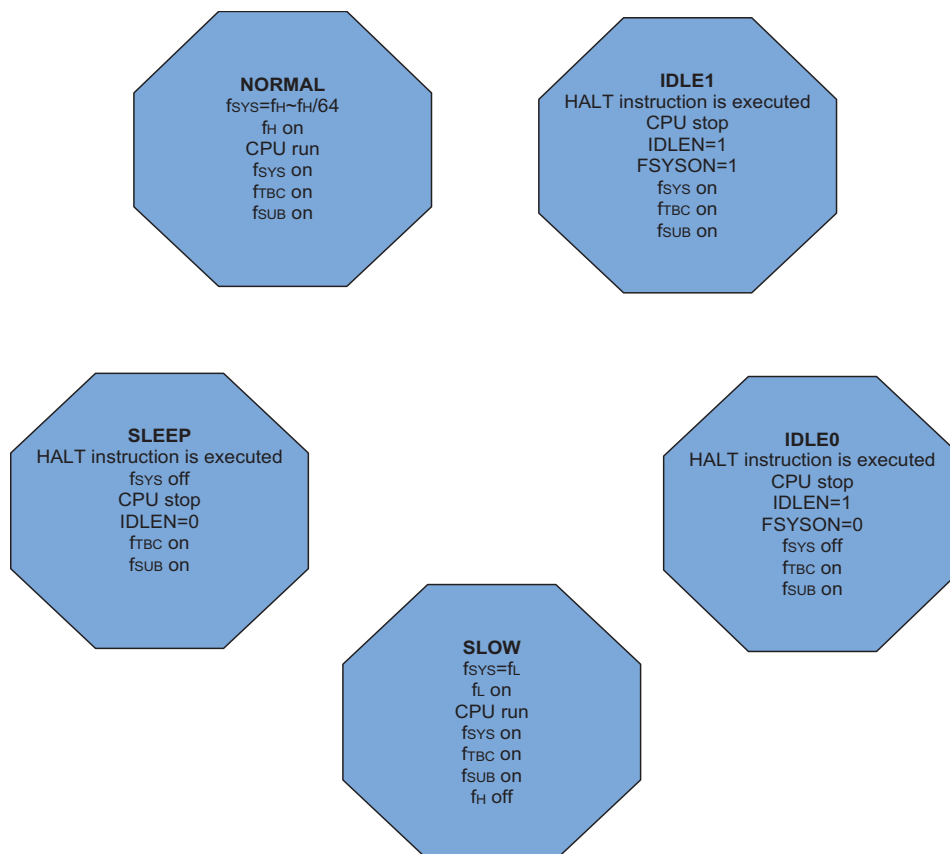

Operating Mode Switching

The device can switch between operating modes dynamically allowing the user to select the best performance/power ratio for the present task in hand. In this way microcontroller operations that do not require high performance can be executed using slower clocks thus requiring less operating current and prolonging battery life in portable applications.

In simple terms, Mode Switching between the NORMAL Mode and SLOW Mode is executed using the HLCLK bit and CKS2~CKS0 bits in the SMOD register while Mode Switching from the NORMAL/SLOW Modes to the SLEEP/IDLE Modes is executed via the HALT instruction. When a HALT instruction is executed, whether the device enters the IDLE Mode or the SLEEP Mode is determined by the condition of the IDLEN bit in the SMOD register and FSYSON in the CTRL register.

When the HLCLK bit switches to a low level, which implies that clock source is switched from the high speed clock source, fH, to the clock source, fH/2~fH/64 or fL. If the clock is from the fL, the high speed clock source will stop running to conserve power. When this happens it must be noted that the fH/16 and fH/64 internal clock sources will also stop running, which may affect the operation of other internal functions such as the TMs. The accompanying flowchart shows what happens when the device moves between the various operating modes.

NORMAL Mode to SLOW Mode Switching

When running in the NORMAL Mode, which uses the high speed system oscillator, and therefore consumes more power, the system clock can switch to run in the SLOW Mode by setting the HLCLK bit to "0" and setting the CKS2~CKS0 bits to "000" or "001" in the SMOD register. This will then use the low speed system oscillator which will consume less power. Users may decide to do this for certain operations which do not require high performance and can subsequently reduce power consumption.

The SLOW Mode is sourced from the LIRC oscillator and therefore requires this oscillator to be stable before full mode switching occurs. This is monitored using the LTO bit in the SMOD register.

SLOW Mode to NORMAL Mode Switching

In SLOW Mode the system uses LIRC low speed system oscillator. To switch back to the NORMAL Mode, where the high speed system oscillator is used, the HLCLK bit should be set to "1" or HLCLK bit is "0", but CKS2~CKS0 is set to "010", "011", "100", "101", "110" or "111". As a certain amount of time will be required for the high frequency clock to stabilise, the status of the HTO bit is checked. The amount of time required for high speed system oscillator stabilization depends upon which high speed system oscillator type is used.

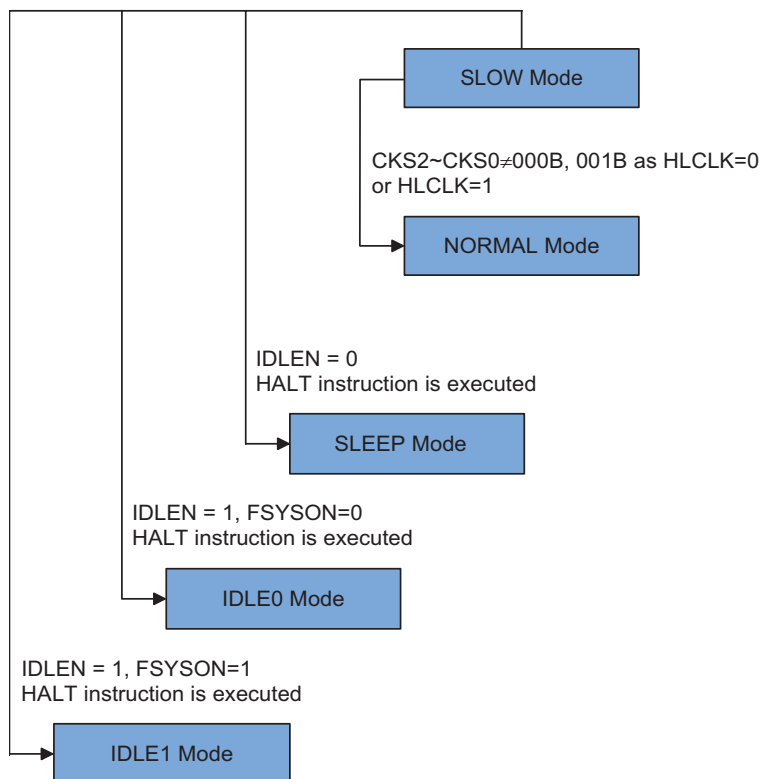
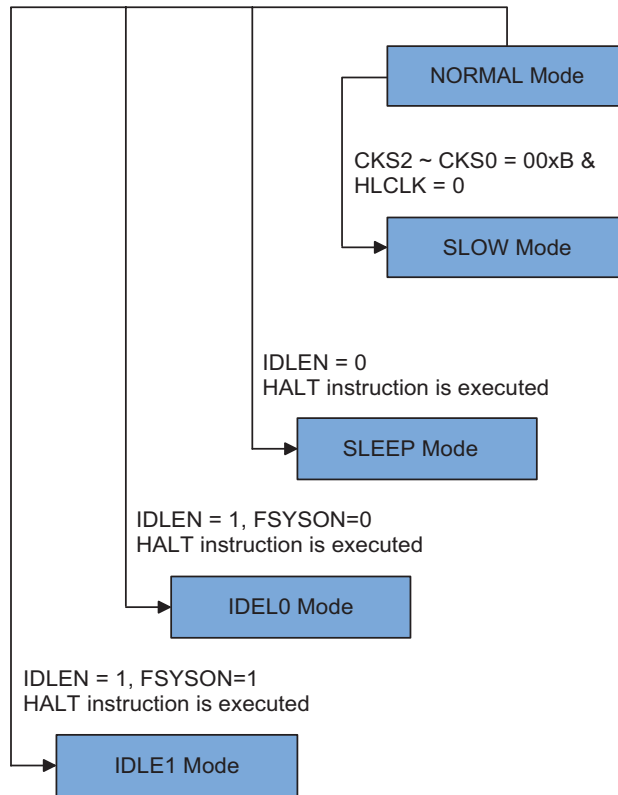

Entering the SLEEP Mode

There is only one way for the device to enter the SLEEP Mode and that is to execute the "HALT" instruction in the application program with the IDLEN bit in SMOD register equal to "0". When this instruction is executed under the conditions described above, the following will occur:

- The system clock and Time Base clock will be stopped and the application program will stop at the "HALT" instruction. but the WDT or LVD will remain with the clock source coming from the f_L clock.
- The Data Memory contents and registers will maintain their present condition.
- The WDT will be cleared and resume counting.
- The I/O ports will maintain their present conditions.
- In the status register, the Power Down flag, PDF, will be set and the Watchdog time-out flag, TO, will be cleared.

Entering the IDLE0 Mode

There is only one way for the device to enter the IDLE0 Mode and that is to execute the "HALT" instruction in the application program with the IDLEN bit in SMOD register equal to "1" and the FSYSON bit in CTRL register equal to "0". When this instruction is executed under the conditions described above, the following will occur:

- The system clock will be stopped and the application program will stop at the "HALT" instruction, but the Time Base clock f_{TBC} and the low frequency f_L clock will be on.
- The Data Memory contents and registers will maintain their present condition.
- The WDT will be cleared and resume counting.
- The I/O ports will maintain their present conditions.
- In the status register, the Power Down flag, PDF, will be set and the Watchdog time-out flag, TO, will be cleared.

Entering the IDLE1 Mode

There is only one way for the device to enter the IDLE1 Mode and that is to execute the "HALT" instruction in the application program with the IDLEN bit in SMOD register equal to "1" and the FSYSON bit in CTRL register equal to "1". When this instruction is executed under the conditions described above, the following will occur:

- The system clock and Time Base clock and f_{TBC} and the low frequency f_L will be on and the application program will stop at the "HALT" instruction.
- The Data Memory contents and registers will maintain their present condition.
- The WDT will be cleared and resume counting.
- The I/O ports will maintain their present conditions.
- In the status register, the Power Down flag, PDF, will be set and the Watchdog time-out flag, TO, will be cleared.

Standby Current Considerations

As the main reason for entering the SLEEP or IDLE Mode is to keep the current consumption of the device to as low a value as possible, perhaps only in the order of several micro-amps except in the IDLE1 Mode, there are other considerations which must also be taken into account by the circuit designer if the power consumption is to be minimised. Special attention must be made to the I/O pins on the device. All high-impedance input pins must be connected to either a fixed high or low level as any floating input pins could create internal oscillations and result in increased current consumption. This also applies to devices which have different package types, as there may be unbonded pins. These must either be setup as outputs or if setup as inputs must have pull-high resistors connected.

Care must also be taken with the loads, which are connected to I/O pins, which are setup as outputs. These should be placed in a condition in which minimum current is drawn or connected only to external circuits that do not draw current, such as other CMOS inputs. In the IDLE1 Mode the system oscillator is on, if the system oscillator is from the high speed system oscillator, the additional standby current will also be perhaps in the order of several hundred micro-amps.

Wake-up

After the system enters the SLEEP or IDLE Mode, it can be woken up from one of various sources listed as follows:

- An external falling edge on Port A
- A system interrupt
- A WDT overflow

If the device is woken up by a WDT overflow, a Watchdog Timer reset will be initiated. The actual source of the wake-up can be determined by examining the TO and PDF flags. The PDF flag is cleared by a system power-up or executing the clear Watchdog Timer instructions and is set when executing the "HALT" instruction. The TO flag is set if a WDT time-out occurs, and causes a wake-up that only resets the Program Counter and Stack Pointer, the other flags remain in their original status.

Each pin on Port A can be setup using the PAWU register to permit a negative transition on the pin to wake-up the system. When a Port A pin wake-up occurs, the program will resume execution at the instruction following the "HALT" instruction. If the system is woken up by an interrupt, then two possible situations may occur. The first is where the related interrupt is disabled or the interrupt is enabled but the stack is full, in which case the program will resume execution at the instruction following the "HALT" instruction. In this situation, the interrupt which woke-up the device will not be immediately serviced, but will rather be serviced later when the related interrupt is finally enabled or when a stack level becomes free. The other situation is where the related interrupt is enabled and the stack is not full, in which case the regular interrupt response takes place. If an interrupt request flag is set high before entering the SLEEP or IDLE Mode, the wake-up function of the related interrupt will be disabled.

Watchdog Timer

The Watchdog Timer is provided to prevent program malfunctions or sequences from jumping to unknown locations, due to certain uncontrollable external events such as electrical noise.

Watchdog Timer Clock Source

The Watchdog Timer clock source is provided by the internal f_s clock which is in turn supplied by the LIRC oscillator. The Watchdog Timer source clock is then subdivided by a ratio of 2^8 to 2^{18} to give longer timeouts, the actual value being chosen using the WS2~WS0 bits in the WDTC register. The LIRC internal oscillator has an approximate period of 32kHz at a supply voltage of 5V. However, it should be noted that this specified internal clock period can vary with V_{DD} , temperature and process variations.

Note that the Watchdog Timer function is always enabled, it can be controlled by WDTC register.

Watchdog Timer Control Register

A single register, WDTC, controls the required timeout period as well as the enable operation. The WDTC register is initiated to 01010011B at any reset but keeps unchanged at the WDT time-out occurrence in a power down state.

WDTC Register

Bit	7	6	5	4	3	2	1	0
Name	WE4	WE3	WE2	WE1	WE0	WS2	WS1	WS0
R/W	R/W	R/W	R/W	R/W	R/W	R/W	R/W	R/W
POR	0	1	0	1	0	0	1	1

Bit 7~3 **WE4 ~ WE0**: WDT function software control
 10101 or 01010: Enabled
 Other values: Reset MCU (Reset will be active after 1~2 LIRC clock for debounce time.)
 When these bits are changed by the environmental noise to reset the microcontroller, the WRF bit in the CTRL register will be set to 1.

Bit 2~0 **WS2 ~ WS0**: WDT Time-out period selection
 000: $2^8/f_s$
 001: $2^{10}/f_s$
 010: $2^{12}/f_s$
 011: $2^{14}/f_s$
 100: $2^{15}/f_s$
 101: $2^{16}/f_s$
 110: $2^{17}/f_s$
 111: $2^{18}/f_s$

These three bits determine the division ratio of the Watchdog Timer source clock, which in turn determines the timeout period.

CTRL Register

Bit	7	6	5	4	3	2	1	0
Name	FSYSON	—	—	—	—	LVRF	LRF	WRF
R/W	R/W	—	—	—	—	R/W	R/W	R/W
POR	0	—	—	—	—	×	0	0

- Bit 7 **FSYSON:** f_{SYS} Control IDLE Mode
Describe elsewhere
- Bit 6~3 Unimplemented, read as "0"
- Bit 2 **LVRF:** LVR function reset flag
Describe elsewhere
- Bit 1 **LRF:** LVR Control register software reset flag
Describe elsewhere
- Bit 0 **WRF:** WDT Control register software reset flag
0: Not occur
1: Occurred

This bit is set to 1 by the WDT Control register software reset and cleared by the application program. Note that this bit can only be cleared to 0 by the application program.

Watchdog Timer Operation

The Watchdog Timer operates by providing a device reset when its timer overflows. This means that in the application program and during normal operation the user has to strategically clear the Watchdog Timer before it overflows to prevent the Watchdog Timer from executing a reset. This is done using the clear watchdog instructions. If the program malfunctions for whatever reason, jumps to an unknown location, or enters an endless loop, the clear WDT instruction will not be executed in the correct manner, in which case the Watchdog Timer will overflow and reset the device. There are five bits, WE4~WE0, in the WDTC register to enable the WDT function. When the WE4~WE0 bits value is equal to 01010B or 10101B, the WDT function is enabled. However, if the WE4~WE0 bits are changed to any other values except 01010B and 10101B, which is caused by the environmental noise, it will reset the microcontroller after 2~3 LIRC clock cycles.

WE4 ~ WE0 Bits	WDT Function
01010B or 10101B	Enable
Any other values	Reset MCU

Watchdog Timer Enable/Disable Control

Under normal program operation, a Watchdog Timer time-out will initialise a device reset and set the status bit TO. However, if the system is in the SLEEP or IDLE Mode, when a Watchdog Timer time-out occurs, the TO bit in the status register will be set and only the Program Counter and Stack Pointer will be reset. Three methods can be adopted to clear the contents of the Watchdog Timer. The first is a WDT reset, which means a certain value is written into the WE4~WE0 bit field except 01010B and 10101B, the second is using the Watchdog Timer software clear instruction and the third is via a HALT instruction.

There is only one method of using software instruction to clear the Watchdog Timer. That is to use the single "CLR WDT" instruction to clear the WDT.

The maximum time-out period is when the 2^{18} division ratio is selected. As an example, with a 32 kHz LIRC oscillator as its source clock, this will give a maximum watchdog period of around 8 seconds for the 2^{18} division ratio, and a minimum timeout of 7.8ms for the 2^8 division ration.

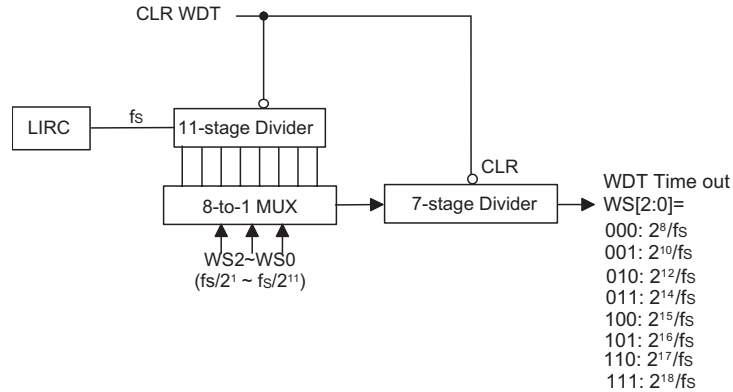

Watchdog Timer

Reset and Initialisation

A reset function is a fundamental part of any microcontroller ensuring that the device can be set to some predetermined condition irrespective of outside parameters. The most important reset condition is after power is first applied to the microcontroller. In this case, internal circuitry will ensure that the microcontroller, after a short delay, will be in a well defined state and ready to execute the first program instruction. After this power-on reset, certain important internal registers will be set to defined states before the program commences. One of these registers is the Program Counter, which will be reset to zero forcing the microcontroller to begin program execution from the lowest Program Memory address.

Another type of reset is when the Watchdog Timer overflows and resets the microcontroller. All types of reset operations result in different register conditions being setup. Another reset exists in the form of a Low Voltage Reset, LVR, where a full reset is implemented in situations where the power supply voltage falls below a certain threshold.

Reset Functions

There are four ways in which a microcontroller reset can occur, through events occurring internally:

Power-on Reset

The most fundamental and unavoidable reset is the one that occurs after power is first applied to the microcontroller. As well as ensuring that the Program Memory begins execution from the first memory address, a power-on reset also ensures that certain other registers are preset to known conditions. All the I/O port and port control registers will power up in a high condition ensuring that all pins will be first set to inputs.

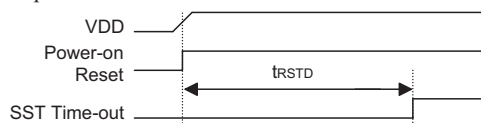

Note: t_{RSTD} is power-on delay, typical time=50ms

Power-On Reset Timing Chart

Low Voltage Reset – LVR

The microcontroller contains a low voltage reset circuit in order to monitor the supply voltage of the device. The LVR function is always enabled with a specific LVR voltage, V_{LVR} . If the supply voltage of the device drops to within a range of $0.9V \sim V_{LVR}$ such as might occur when changing the battery, the LVR will automatically reset the device internally and the LVRF bit in the CTRL register will also be set to 1. For a valid LVR signal, a low voltage, i.e., a voltage in the range between $0.9V \sim V_{LVR}$ must exist for greater than the value t_{LVR} specified in the A.C. characteristics. If the low voltage state does not exceed this value, the LVR will ignore the low supply voltage and will not perform a reset function. The actual V_{LVR} is fixed at a voltage value of 3.15V by the LVS bits in the LVRC register. If the LVS7~LVS0 bits are changed to some certain values by the environmental noise, the LVR will reset the device after 2~3 LIRC clock cycles. When this happens, the LRF bit in the CTRL register will be set to 1. After power on the register will have the value of 01010101B.

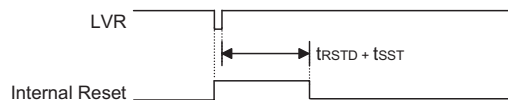

Note: t_{RSTD} is power-on delay, typical time=16.7ms

Low Voltage Reset Timing Chart

• LVRC Register

Bit	7	6	5	4	3	2	1	0
Name	LVS7	LVS6	LVS5	LVS4	LVS3	LVS2	LVS1	LVS0
R/W	R/W	R/W	R/W	R/W	R/W	R/W	R/W	R/W
POR	0	1	0	1	0	1	0	1

Bit 7 ~ 0 **LVS7 ~ LVS0**: LVR Voltage Select control

01010101: 3.15V
00110011: 3.15V
10011001: 3.15V
10101010: 3.15V

Other values: MCU reset – (reset will be active after 2~3 LIRC clock for debounce time)

Note: S/W can write 00H~FFH to control LVR voltage, even to S/W reset MCU. If the MCU reset caused LVRC software reset, the LRF flag of CTRL register will be set.

• CTRL Register

Bit	7	6	5	4	3	2	1	0
Name	FSYSON	—	—	—	—	LVRF	LRF	WRF
R/W	R/W	—	—	—	—	R/W	R/W	R/W
POR	0	—	—	—	—	×	0	0

Bit 7 **FSYSON**: f_{SYS} Control IDLE Mode
Describe elsewhere

Bit 6~3 Unimplemented, read as "0"

Bit 2 **LVRF**: LVR function reset flag
0: Not occur
1: Occurred

This bit is set to 1 when a specific Low Voltage Reset situation condition occurs. This bit can only be cleared to 0 by the application program.

Bit 1 **LRF**: LVR Control register software reset flag
0: Not occur
1: Occurred

This bit is set to 1 if the LVRC register contains any non defined LVR voltage register values. This in effect acts like a software reset function. This bit can only be cleared to 0 by the application program.

Bit 0 **WRF**: WDT Control register software reset flag
Describe elsewhere

Watchdog Time-out Reset during Normal Operation

the Watchdog time-out flag TO will be set to "1" when Watchdog time-out Reset during normal operation.

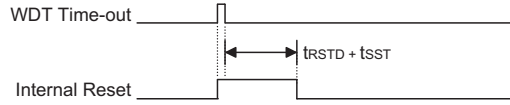

Note: t_{rSTD} is power-on delay, typical time=16.7ms

WDT Time-out Reset during Normal Operation Timing Chart

Watchdog Time-out Reset during SLEEP or IDLE Mode

The Watchdog time-out Reset during SLEEP or IDLE Mode is a little different from other kinds of reset. Most of the conditions remain unchanged except that the Program Counter and the Stack Pointer will be cleared to "0" and the TO flag will be set to "1". Refer to the A.C. Characteristics for t_{sST} details.

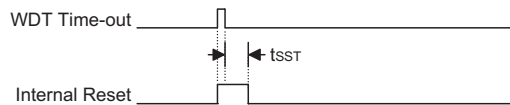

Note: The t_{sST} is 15~16 clock cycles if the system clock source is provided by the HIRC.
 The t_{sST} is 1~2 clock for the LIRC.

WDT Time-out Reset during SLEEP or IDLE Timing Chart

Reset Initial Conditions

The different types of reset described affect the reset flags in different ways. These flags, known as PDF and TO are located in the status register and are controlled by various microcontroller operations, such as the SLEEP or IDLE Mode function or Watchdog Timer. The reset flags are shown in the table:

TO	PDF	RESET Conditions
0	0	Power-on reset
u	u	LVR reset during NORMAL or SLOW Mode operation
1	u	WDT time-out reset during NORMAL or SLOW Mode operation
1	1	WDT time-out reset during IDLE or SLEEP Mode operation

Note: "u" stands for unchanged

The following table indicates the way in which the various components of the microcontroller are affected after a power-on reset occurs.

Item	Condition After RESET
Program Counter	Reset to zero
Interrupts	All interrupts will be disabled
WDT	Clear after reset, WDT begins counting
Timer Modules	Timer Modules will be turned off
Input/Output Ports	I/O ports will be setup as inputs and AN0~AN5 as A/D input pins
Stack Pointer	Stack Pointer will point to the top of the stack

The different kinds of resets all affect the internal registers of the microcontroller in different ways. To ensure reliable continuation of normal program execution after a reset occurs, it is important to know what condition the microcontroller is in after a particular reset occurs. The following table describes how each type of reset affects each of the microcontroller internal registers.

Register	Reset (Power On)	WDT Time-out (Normal Operation)	LVR Reset	WDT Time-out (SLEEP/IDLE)
MP0	x xxx x xxx	x xxx x xxx	x xxx x xxx	u uuu u uuu
MP1	x xxx x xxx	x xxx x xxx	x xxx x xxx	u uuu u uuu
BP	- - - - - 0	- - - - - 0	- - - - - 0	- - - - - u
ACC	x xxx x xxx	u uuu u uuu	x xxx x xxx	u uuu u uuu
PCL	0 0 0 0 0 0 0 0	0 0 0 0 0 0 0 0	0 0 0 0 0 0 0 0	0 0 0 0 0 0 0 0
TBLP	x xxx x xxx	u uuu u uuu	x xxx x xxx	u uuu u uuu
TBLH	x xxx x xxx	u uuu u uuu	x xxx x xxx	u uuu u uuu
TBHP	- - - - - x x x	- - - - - u u u	- - - - - x x x	- - - - - u u u
STATUS	- - 0 0 x xxx	- - 1 u u u u u	- - u u x xxx	- - 1 1 u u u u
SMOD	0 0 0 0 0 0 1 1	0 0 0 0 0 0 1 1	0 0 0 0 0 0 1 1	u u u u u u u u
LVDC	- - 0 0 - 0 0 0	- - 0 0 - 0 0 0	- - 0 0 - 0 0 0	- - u u - u u u
LVRC	0 1 0 1 0 1 0 1	0 1 0 1 0 1 0 1	0 1 0 1 0 1 0 1	u u u u u u u u
WDTC	0 1 0 1 0 0 1 1	0 1 0 1 0 0 1 1	0 1 0 1 0 0 1 1	u u u u u u u u
TBC	0 0 1 1 - - - -	0 0 1 1 - - - -	0 0 1 1 - - - -	u u u u - - - -
INTC0	- 0 0 0 0 0 0 0 0	- 0 0 0 0 0 0 0 0	- 0 0 0 0 0 0 0 0	- u u u u u u u
INTC1	0 0 0 0 0 0 0 0	0 0 0 0 0 0 0 0	0 0 0 0 0 0 0 0	u u u u u u u u
INTC2	- 0 0 0 - 0 0 0	- 0 0 0 - 0 0 0	- 0 0 0 - 0 0 0	- u u u - u u u
MFI0	0 0 0 0 0 0 0 0	0 0 0 0 0 0 0 0	0 0 0 0 0 0 0 0	u u u u u u u u
MFI1	0 0 0 0 0 0 0 0	0 0 0 0 0 0 0 0	0 0 0 0 0 0 0 0	u u u u u u u u
MFI2	0 0 0 0 0 0 0 0	0 0 0 0 0 0 0 0	0 0 0 0 0 0 0 0	u u u u u u u u
MFI3	0 0 0 0 0 0 0 0	0 0 0 0 0 0 0 0	0 0 0 0 0 0 0 0	u u u u u u u u
MFI4	- - 0 0 - - 0 0	- - 0 0 - - 0 0	- - 0 0 - - 0 0	- - u u - - u u
PAWU	0 0 0 0 0 0 0 0	0 0 0 0 0 0 0 0	0 0 0 0 0 0 0 0	u u u u u u u u
PAPU	0 0 0 0 0 0 0 0	0 0 0 0 0 0 0 0	0 0 0 0 0 0 0 0	u u u u u u u u
PA	1 1 1 1 1 1 1 1	1 1 1 1 1 1 1 1	1 1 1 1 1 1 1 1	u u u u u u u u
PAC	1 1 1 1 1 1 1 1	1 1 1 1 1 1 1 1	1 1 1 1 1 1 1 1	u u u u u u u u
PBPU	- - - - 0 0 0 0	- - - - 0 0 0 0	- - - - 0 0 0 0	- - - - u u u u
PB	- - - - 1 1 1 1	- - - - 1 1 1 1	- - - - 1 1 1 1	- - - - u u u u
PBC	- - - - 1 1 1 1	- - - - 1 1 1 1	- - - - 1 1 1 1	- - - - u u u u
PCPU	- - 0 0 0 0 0 0	- - 0 0 0 0 0 0	- - 0 0 0 0 0 0	- - u u u u u u
PC	- - 1 1 1 1 1 1	- - 1 1 1 1 1 1	- - 1 1 1 1 1 1	- - u u u u u u
PCC	- - 1 1 1 1 1 1	- - 1 1 1 1 1 1	- - 1 1 1 1 1 1	- - u u u u u u
INTEG	- 0 0 0 0 0 0 0 0	- 0 0 0 0 0 0 0 0	- 0 0 0 0 0 0 0 0	- u u u u u u u
IICC0	- - - - 0 0 0 -	- - - - 0 0 0 -	- - - - 0 0 0 -	- - - - u u u -
IICC1	1 0 0 0 0 0 0 1	1 0 0 0 0 0 0 1	1 0 0 0 0 0 0 1	u u u u u u u u
IICD	x xxx x xxx	x xxx x xxx	x xxx x xxx	u u u u u u u u
IICA	x xxx x x x -	x xxx x x x -	x xxx x x x -	u u u u u u u -
I2CTOC	0 0 0 0 0 0 0 0	0 0 0 0 0 0 0 0	0 0 0 0 0 0 0 0	u u u u u u u u
NF_VIH	0 0 - 1 1 0 0 1	0 0 - 1 1 0 0 1	0 0 - 1 1 0 0 1	u - - u u u u u
NF_VIL	0 0 - 0 1 0 1 0	0 0 - 0 1 0 1 0	0 0 - 0 1 0 1 0	0 0 - u u u u u
HCHK_NUM	- - - 0 0 0 0 0	- - - 0 0 0 0 0	- - - 0 0 0 0 0	- - - u u u u u
HNF_MSEL	- - - - 0 0 0 0	- - - - 0 0 0 0	- - - - 0 0 0 0	- - - - u u u u
CAPTC0	0 0 0 0 0 0 0 0	0 0 0 0 0 0 0 0	0 0 0 0 0 0 0 0	u u u u u u u u

Register	Reset (Power On)	WDT Time-out (Normal Operation)	LVR Reset	WDT Time-out (SLEEP/IDLE)
CAPTC1	0000 0000	0000 0000	0000 0000	uuuu uuuu
CAPTMDL	0000 0000	0000 0000	0000 0000	uuuu uuuu
CAPTMDH	0000 0000	0000 0000	0000 0000	uuuu uuuu
CAPTMAL	0000 0000	0000 0000	0000 0000	uuuu uuuu
CAPTMAH	0000 0000	0000 0000	0000 0000	uuuu uuuu
CAPTMCL	xxxx xxxx	xxxx xxxx	xxxx xxxx	uuuu uuuu
CAPTMCH	xxxx xxxx	xxxx xxxx	xxxx xxxx	uuuu uuuu
OPOMS	00-- -010	00-- -010	00-- -010	uu-- -uuu
OPCM	0000 0000	0000 0000	0000 0000	uuuu uuuu
CPC	1111 0000	1111 0000	1111 0000	uuuu uuuu
CTRL	0--- -x00	0--- -x00	0--- -x00	u--- -uuu
EEC	---- 0000	---- 0000	---- 0000	---- uuuu
EEA	---x xxxx	---x xxxx	---x xxxx	---u uuuu
EED	xxxx xxxx	xxxx xxxx	xxxx xxxx	uuuu uuuu
ADRL	xxxx xxxx	xxxx xxxx	xxxx xxxx	uuuu uuuu
ADRH	---- -x x	---- -x x	---- -x x	---- -u u
ADCR0	011- 0000	011- 0000	011- 0000	uuu- uuuu
ADCR1	0000 0000	0000 0000	0000 0000	uuuu uuuu
ADCR2	---- --00	---- --00	---- --00	---- --u u
ADDL	0000 0000	0000 0000	0000 0000	uuuu uuuu
ADLVDL	0000 0000	0000 0000	0000 0000	uuuu uuuu
ADLVDH	xxxx xx00	xxxx xx00	xxxx xx00	uuuu uuuu
ADHVDL	0000 0000	0000 0000	0000 0000	uuuu uuuu
ADHVDH	---- --00	---- --00	---- --00	---- --u u
PWMC	0000 0000	0000 0000	0000 0000	uuuu uuuu
DUTR0L	0000 0000	0000 0000	0000 0000	uuuu uuuu
DUTR0H	---- --00	---- --00	---- --00	---- --u u
DUTR1L	0000 0000	0000 0000	0000 0000	uuuu uuuu
DUTR1H	---- --00	---- --00	---- --00	---- --u u
DUTR2L	0000 0000	0000 0000	0000 0000	uuuu uuuu
DUTR2H	---- --00	---- --00	---- --00	---- --u u
PRDRL	0000 0000	0000 0000	0000 0000	uuuu uuuu
PRDRH	---- --00	---- --00	---- --00	---- --u u
PWMRL	0000 0000	0000 0000	0000 0000	uuuu uuuu
PWMRH	---- --00	---- --00	---- --00	---- --u u
MCF	0--- 0100	0--- 0100	0--- 0100	0--- uuuu
MCD	--00 0111	--00 0111	--00 0111	--uu uuuu
DTS	0000 0000	0000 0000	0000 0000	uuuu uuuu
PLC	--00 0000	--00 0000	--00 0000	--uu uuuu
HDCR	0001 0000	0001 0000	0001 0000	uuuu uuuu
HDCD	---- -000	---- -000	---- -000	---- -uuu
HDCT0	--00 0000	--00 0000	--00 0000	--uu uuuu
HDCT1	--00 0000	--00 0000	--00 0000	--uu uuuu
HDCT2	--00 0000	--00 0000	--00 0000	--uu uuuu
HDCT3	--00 0000	--00 0000	--00 0000	--uu uuuu
HDCT4	--00 0000	--00 0000	--00 0000	--uu uuuu
HDCT5	--00 0000	--00 0000	--00 0000	--uu uuuu

Register	Reset (Power On)	WDT Time-out (Normal Operation)	LVR Reset	WDT Time-out (SLEEP/IDLE)
HDCT6	--00 0000	--00 0000	--00 0000	--uu uuuu
HDCT7	--00 0000	--00 0000	--00 0000	--uu uuuu
HDCT8	--00 0000	--00 0000	--00 0000	--uu uuuu
HDCT9	--00 0000	--00 0000	--00 0000	--uu uuuu
HDCT10	--00 0000	--00 0000	--00 0000	--uu uuuu
HDCT11	--00 0000	--00 0000	--00 0000	--uu uuuu
MPTC1	0000 00--	0000 00--	0000 00--	uuuu uu--
MPTC2	---1 0011	---1 0011	---1 0011	---u uuuu
TM1C0	0000 0---	0000 0---	0000 0---	uuuu u---
TM1C1	0000 0000	0000 0000	0000 0000	uuuu uuuu
TM1DL	0000 0000	0000 0000	0000 0000	uuuu uuuu
TM1DH	0000 0000	0000 0000	0000 0000	uuuu uuuu
TM1AL	0000 0000	0000 0000	0000 0000	uuuu uuuu
TM1AH	0000 0000	0000 0000	0000 0000	uuuu uuuu
TM1RP	0000 0000	0000 0000	0000 0000	uuuu uuuu
OPACAL	-001 0000	-001 0000	-001 0000	-uuu uuuu
PWMME	--00 0000	--00 0000	--00 0000	--uu uuuu
PWMMD	--00 0000	--00 0000	--00 0000	--uu uuuu
TM0C0	0000 0000	0000 0000	0000 0000	uuuu uuuu
TM0C1	0000 0000	0000 0000	0000 0000	uuuu uuuu
TM0DL	0000 0000	0000 0000	0000 0000	uuuu uuuu
TM0DH	---- --00	---- --00	---- --00	---- --uu
TM0AL	0000 0000	0000 0000	0000 0000	uuuu uuuu
TM0AH	---- --00	---- --00	---- --00	---- --uu
TM2C0	0000 0000	0000 0000	0000 0000	uuuu uuuu
TM2C1	0000 0000	0000 0000	0000 0000	uuuu uuuu
TM2DL	0000 0000	0000 0000	0000 0000	uuuu uuuu
TM2DH	---- --00	---- --00	---- --00	---- --uu
TM2AL	0000 0000	0000 0000	0000 0000	uuuu uuuu
TM2AH	---- --00	---- --00	---- --00	---- --uu
PAPS0	0000 0000	0000 0000	0000 0000	uuuu uuuu
PAPS1	0000 0000	0000 0000	0000 0000	uuuu uuuu
PBPS0	0000 0000	0000 0000	0000 0000	uuuu uuuu
PCPS0	0000 0000	0000 0000	0000 0000	uuuu uuuu
PCPS1	---- 0000	---- 0000	---- 0000	---- uuuu
PRM	---- 0000	---- 0000	---- 0000	---- uuuu

Note: "-" not implement

"u" stands for "unchanged"

"x" stands for "unknown"

Input/Output Ports

Holtek microcontrollers offer considerable flexibility on their I/O ports. With the input or output designation of every pin fully under user program control, pull-high selections for all ports and wake-up selections on certain pins, the user is provided with an I/O structure to meet the needs of a wide range of application possibilities.

The device provides bidirectional input/output lines labeled with port names PA, PB and PC. These I/O ports are mapped to the RAM Data Memory with specific addresses as shown in the Special Purpose Data Memory table. All of these I/O ports can be used for input and output operations. For input operation, these ports are non-latching, which means the inputs must be ready at the T2 rising edge of instruction "MOV A, [m]", where m denotes the port address. For output operation, all the data is latched and remains unchanged until the output latch is rewritten.

I/O Register List

Register Name	Bit							
	7	6	5	4	3	2	1	0
PA	D7	D6	D5	D4	D3	D2	D1	D0
PAC	D7	D6	D5	D4	D3	D2	D1	D0
PAPU	D7	D6	D5	D4	D3	D2	D1	D0
PAWU	D7	D6	D5	D4	D3	D2	D1	D0
PB	—	—	—	—	D3	D2	D1	D0
PBC	—	—	—	—	D3	D2	D1	D0
PBPU	—	—	—	—	D3	D2	D1	D0
PC	—	—	D5	D4	D3	D2	D1	D0
PCC	—	—	D5	D4	D3	D2	D1	D0
PCPU	—	—	D5	D4	D3	D2	D1	D0

Pull-high Resistors

Many product applications require pull-high resistors for their switch inputs usually requiring the use of an external resistor. To eliminate the need for these external resistors, all I/O pins, when configured as an input have the capability of being connected to an internal pull-high resistor. These pull-high resistors are selected using registers PAPU~PCPU, and are implemented using weak PMOS transistors.

PAPU Register

Bit	7	6	5	4	3	2	1	0
Name	D7	D6	D5	D4	D3	D2	D1	D0
R/W	R/W	R/W	R/W	R/W	R/W	R/W	R/W	R/W
POR	0	0	0	0	0	0	0	0

Bit 7 ~ 0 I/O Port A bit7~ bit 0 Pull-High Control
 0: Disable
 1: Enable

PBPU Register

Bit	7	6	5	4	3	2	1	0
Name	—	—	—	—	D3	D2	D1	D0
R/W	—	—	—	—	R/W	R/W	R/W	R/W
POR	—	—	—	—	0	0	0	0

Bit 7 ~ 4 Unimplemented, read as "0"
 Bit 3 ~ 0 I/O Port B bit3~ bit 0 Pull-High Control
 0: Disable
 1: Enable

PCPU Register

Bit	7	6	5	4	3	2	1	0
Name	—	—	D5	D4	D3	D2	D1	D0
R/W	—	—	R/W	R/W	R/W	R/W	R/W	R/W
POR	—	—	0	0	0	0	0	0

Bit 7 ~ 6 Unimplemented, read as "0"
 Bit 5 ~ 0 I/O Port C bit5~ bit 0 Pull-High Control
 0: Disable
 1: Enable

Port A Wake-up

The HALT instruction forces the microcontroller into the SLEEP or IDLE Mode which preserves power, a feature that is important for battery and other low-power applications. Various methods exist to wake-up the microcontroller, one of which is to change the logic condition on one of the Port A pins from high to low. This function is especially suitable for applications that can be woken up via external switches. Each pin on Port A can be selected individually to have this wake-up feature using the PAWU register.

PAWU Register

Bit	7	6	5	4	3	2	1	0
Name	D7	D6	D5	D4	D3	D2	D1	D0
R/W	R/W	R/W	R/W	R/W	R/W	R/W	R/W	R/W
POR	0	0	0	0	0	0	0	0

Bit 7 ~ 0 I/O Port A bit 7 ~ bit 0 Wake Up Control
 0: Disable
 1: Enable

I/O Port Control Registers

Each I/O port has its own control register known as PAC~PCC, to control the input/output configuration. With this control register, each CMOS output or input can be reconfigured dynamically under software control. Each pin of the I/O ports is directly mapped to a bit in its associated port control register. For the I/O pin to function as an input, the corresponding bit of the control register must be written as a "1". This will then allow the logic state of the input pin to be directly read by instructions. When the corresponding bit of the control register is written as a "0", the I/O pin will be setup as a CMOS output. If the pin is currently setup as an output, instructions can still be used to read the output register. However, it should be noted that the program will in fact only read the status of the output data latch and not the actual logic status of the output pin.

PAC Register

Bit	7	6	5	4	3	2	1	0
Name	D7	D6	D5	D4	D3	D2	D1	D0
R/W	R/W	R/W	R/W	R/W	R/W	R/W	R/W	R/W
POR	1	1	1	1	1	1	1	1

Bit 7 ~ 0 I/O Port A bit 7~bit 0 Input/Output Control
 0: Output
 1: Input

PBC Register

Bit	7	6	5	4	3	2	1	0
Name	—	—	—	—	D3	D2	D1	D0
R/W	—	—	—	—	R/W	R/W	R/W	R/W
POR	—	—	—	—	1	1	1	1

Bit 7 ~ 4 Unimplemented, read as "0"
 Bit 3 ~ 0 I/O Port B bit3~bit 0 Input/Output Control
 0: Output
 1: Input

PCC Register

Bit	7	6	5	4	3	2	1	0
Name	—	—	D5	D4	D3	D2	D1	D0
R/W	—	—	R/W	R/W	R/W	R/W	R/W	R/W
POR	—	—	1	1	1	1	1	1

Bit 7 ~ 6 Unimplemented, read as "0"
 Bit 5 ~ 0 I/O Port C bit 5~bit 0 Input/Output Control
 0: Output
 1: Input

Pin-sharing Functions

PAPS0 Register

Bit	7	6	5	4	3	2	1	0
Name	PA3S1	PA3S0	PA2S1	PA2S0	PA1S1	PA1S0	PA0S1	PA0S0
R/W	R/W	R/W	R/W	R/W	R/W	R/W	R/W	R/W
POR	0	0	0	0	0	0	0	0

Bit 7 ~ 6 **PA3S1~PA3S0:** PA3 Pin Share Setting
 00: PA3/TCK2/H1
 01: C1P
 10: PA3/TCK2/H1
 11: PA3/TCK2/H1

Bit 5 ~ 4 **PA2S1~PA2S0:** PA2 Pin Share Setting
 00: PA2
 01: SCL
 10: PA2
 11: PA2

Bit 3 ~ 2 **PA1S1~PA1S0:** PA1 Pin Share Setting
 00: PA1/TCK3
 01: AN2/AP
 10: PA1/TCK3
 11: PA1/TCK3

Bit 1 ~ 0 **PA0S1~PA0S0:** PA0 Pin Share Setting
 00: PA0
 01: SDA
 10: PA0
 11: PA0

PAPS1 Register

Bit	7	6	5	4	3	2	1	0
Name	PA7S1	PA7S0	PA6S1	PA6S0	PA5S1	PA5S0	PA4S1	PA4S0
R/W	R/W	R/W	R/W	R/W	R/W	R/W	R/W	R/W
POR	0	0	0	0	0	0	0	0

Bit 7 ~ 6 **PA7S1~PA7S0:** PA7 Pin Share Setting
 00: PA7/NFIN
 01: AN1
 10: PA7/NFIN
 11: PA7/NFIN

Bit 5 ~ 4 **PA6S1~PA6S0:** PA6 Pin Share Setting
 00: PA6
 01: [C1N] if pin-remap enabled
 10: AN0
 11: PA6

Bit 3 ~ 2 **PA5S1~PA5S0:** PA5 Pin Share Setting
 00: PA5/H3
 01: [SCL] if pin-remap enabled
 10: C3P
 11: PA5/H3

Bit 1 ~ 0 **PA4S1~PA4S0:** PA4 Pin Share Setting
 00: PA4/H2
 01: [SDA] if pin-remap enabled
 10: C2P
 11: [C1N] if pin-remap enabled

PBPS0 Register

Bit	7	6	5	4	3	2	1	0
Name	PB3S1	PB3S0	PB2S1	PB2S0	PB1S1	PB1S0	PB0S1	PB0S0
R/W	R/W	R/W	R/W	R/W	R/W	R/W	R/W	R/W
POR	0	0	0	0	0	0	0	0

- Bit 7 ~ 6 **PB3S1~PB3S0:** PB3 Pin Share Setting
 00: PB3/TCK1
 01: C1N if pin-remap disabled
 10: PB3/TCK1
 11: PB3/TCK1
- Bit 5 ~ 4 **PB2S1~PB2S0:** PB2 Pin Share Setting
 00: PB2
 01: HCO
 10: AN5
 11: PB2
- Bit 3 ~ 2 **PB1S1~PB1S0:** PB1 Pin Share Setting
 00: PB1/CTIN
 01: HBO
 10: AN4
 11: PB1/CTIN
- Bit 1 ~ 0 **PB0S1~PB0S0:** PB0 Pin Share Setting
 00: PB0
 01: HAO
 10: AN3
 11: PB0

PCPS0 Register

Bit	7	6	5	4	3	2	1	0
Name	PC3S1	PC3S0	PC2S1	PC2S0	PC1S1	PC1S0	PC0S1	PC0S0
R/W	R/W	R/W	R/W	R/W	R/W	R/W	R/W	R/W
POR	0	0	0	0	0	0	0	0

- Bit 7 ~ 6 **PC3S1~PC3S0:** PC3 Pin Share Setting
 00: PC3
 01: TP1_1
 10: GBB
 11: PC3
- Bit 5 ~ 4 **PC2S1~PC2S0:** PC2 Pin Share Setting
 00: PC2
 01: TP1_0
 10: GBT
 11: PC2
- Bit 3 ~ 2 **PC1S1~PC1S0:** PC1 Pin Share Setting
 00: PC1
 01: TP0_1
 10: GAB
 11: PC1
- Bit 1 ~ 0 **PC0S1~PC0S0:** PC0 Pin Share Setting
 00: PC0
 01: TP0_0
 10: GAT
 11: PC0

PCPS1 Register

Bit	7	6	5	4	3	2	1	0
Name	—	—	—	—	PC5S1	PC5S0	PC4S1	PC4S0
R/W	—	—	—	—	R/W	R/W	R/W	R/W
POR	—	—	—	—	0	0	0	0

- Bit 7 ~ 4 Unimplemented, read as "0"
- Bit 3 ~ 2 **PC5S1~PC5S0:** PC5 Pin Share Setting
 00: PC5
 01: TP2_1
 10: GCB
 11: PC5
- Bit 1 ~ 0 **PC4S1~PC4S0:** PC4 Pin Share Setting
 00: PC4
 01: TP2_0
 10: GCT
 11: PC4

Pin-remapping Functions

The flexibility of the microcontroller range is greatly enhanced by the use of pins that have more than one function.

Limited numbers of pins can force serious design constraints on designers but by supplying pins with multi-functions, many of these difficulties can be overcome. The way in which the pin function of each pin is selected is different for each function and a priority order is established where more than one pin function is selected simultaneously. Additionally there are a series of PRM register to establish certain pin functions.

Pin-remapping Registers

The limited number of supplied pins in a package can impose restrictions on the amount of functions a certain device can contain. However by allowing the same pins to share several different functions and providing a means of function selection, a wide range of different functions can be incorporated into even relatively small package sizes. Some devices include PRM register which can select the functions of certain pins.

PRM Register

Bit	7	6	5	4	3	2	1	0
Name	—	—	—	—	C1NPS1	C1NPS0	SDAPS	SCLPS
R/W	—	—	—	—	R/W	R/W	R/W	R/W
POR	—	—	—	—	0	0	0	0

- Bit 7 ~ 4 Unimplemented, read as "0"
- Bit 3 ~ 2 **C1NPS1~C1NPS0:**
 00: C1N on PB3
 01: C1N on PA6
 10: C1N on PA4
 11: C1N Reserved
- Bit 1 **SDAPS:**
 0: SDA on PA0
 1: SDA on PA4
- Bit 0 **SCLPS:**
 0: SCL on PA2
 1: SCL on PA5

I/O Pin Structures

The accompanying diagrams illustrate the internal structures of some generic I/O pin types. As the exact logical construction of the I/O pin will differ from these drawings, they are supplied as a guide only to assist with the functional understanding of the I/O pins. The wide range of pin-shared structures does not permit all types to be shown.

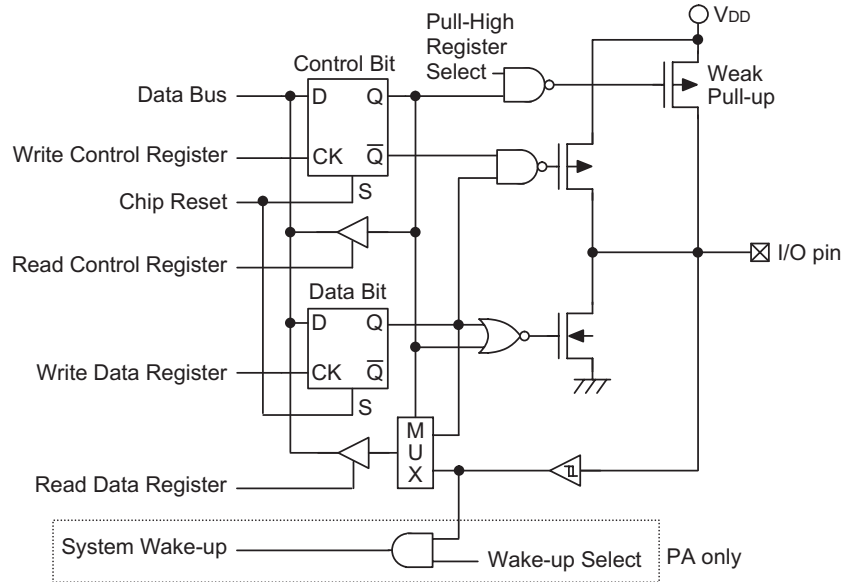

Generic Input/Output Structure

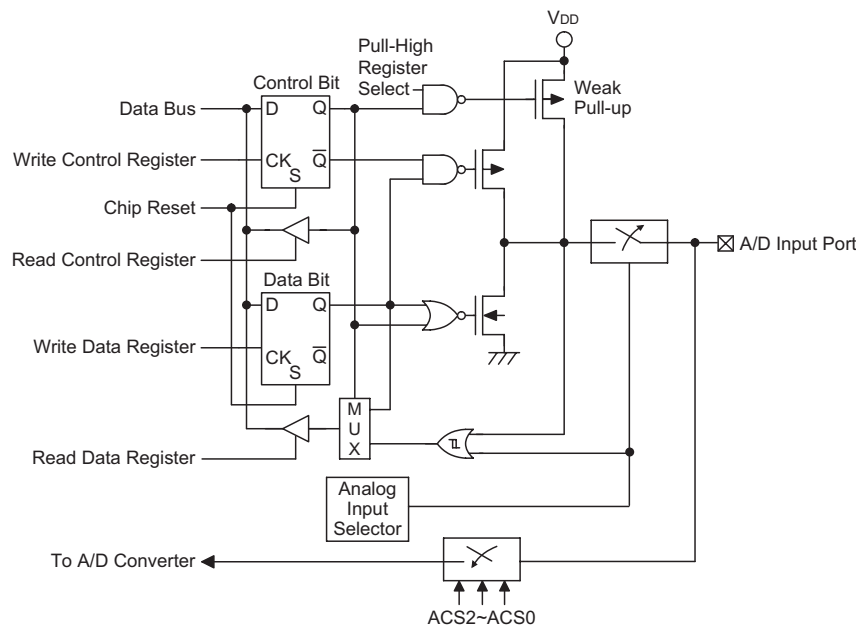

A/D Input/Output Structure

Programming Considerations

Within the user program, one of the first things to consider is port initialisation. After a reset, all of the I/O data and port control registers will be set high. This means that all I/O pins will default to an input state, the level of which depends on the other connected circuitry and whether pull-high selections have been chosen. If the port control registers, PAC~PCC, are then programmed to setup some pins as outputs, these output pins will have an initial high output value unless the associated port data registers, PA~PC, are first programmed. Selecting which pins are inputs and which are outputs can be achieved byte-wide by loading the correct values into the appropriate port control register or by programming individual bits in the port control register using the "SET [m].i" and "CLR [m].i" instructions. Note that when using these bit control instructions, a read-modify-write operation takes place. The microcontroller must first read in the data on the entire port, modify it to the required new bit values and then rewrite this data back to the output ports.

Port A has the additional capability of providing wake-up functions. When the device is in the SLEEP or IDLE Mode, various methods are available to wake the device up. One of these is a high to low transition of any of the Port A pins. Single or multiple pins on Port A can be setup to have this function.

Timer Modules – TM

One of the most fundamental functions in any microcontroller device is the ability to control and measure time. To implement time related functions the device includes several Timer Modules, abbreviated to the name TM. The TMs are multi-purpose timing units and serve to provide operations such as Timer/Counter, Input Capture, Compare Match Output and Single Pulse Output as well as being the functional unit for the generation of PWM signals. Each of the TMs has two individual interrupts. The addition of input and output pins for each TM ensures that users are provided with timing units with a wide and flexible range of features.

The common features of the different TM types are described here with more detailed information provided in the individual Compact and Standard TM section.

Introduction

The device contains three TMs, a 10-bit Compact TM, a 16-bit Compact TM and a 10-bit Standard TM, each TM having a reference name of TM0, TM1 and TM2. Although similar in nature, the different TM types vary in their feature complexity. The common features to the Compact and Standard TMs will be described in this section and the detailed operation will be described in corresponding sections. The main features and differences between the two types of TMs are summarised in the accompanying table.

Function	CTM	STM
Timer/Counter	√	√
I/P Capture	—	√
Compare Match Output	√	√
PWM Channels	1	1
Single Pulse Output	—	√
PWM Alignment	Edge	Edge
PWM Adjustment Period & Duty	Duty or Period	Duty or Period

TM Function Summary

TM0	TM1	TM2
10-bit CTM	16-bit CTM	10-bit STM

TM Name/Type Reference

TM Operation

The two different types of TMs offer a diverse range of functions, from simple timing operations to PWM signal generation. The key to understanding how the TM operates is to see it in terms of a free running counter whose value is then compared with the value of pre-programmed internal comparators. When the free running counter has the same value as the pre-programmed comparator, known as a compare match situation, a TM interrupt signal will be generated which can clear the counter and perhaps also change the condition of the TM output pin. The internal TM counter is driven by a user selectable clock source, which can be an internal clock or an external pin.

TM Clock Source

The clock source which drives the main counter in each TM can originate from various sources. The selection of the required clock source is implemented using the TnCK2~TnCK0 bits in the TM control registers. The clock source can be a ratio of either the system clock f_{SYS} or the internal high clock f_{IH} , the f_{TBC} clock source or the external TCKn pin. The TCKn pin clock source is used to allow an external signal to drive the TM as an external clock source or for event counting.

TM Interrupts

The two different types of TMs have two internal interrupts, the internal comparator A or comparator P, which generate a TM interrupt when a compare match condition occurs. When a TM interrupt is generated, it can be used to clear the counter and also to change the state of the TM output pin.

TM External Pins

Each of the TMs, irrespective of what type, has one TM input pin, with the label TCKn. The TM input pin, is essentially a clock source for the TM and is selected using the TnCK2~TnCK0 bits in the TMnC0 register. This external TM input pin allows an external clock source to drive the internal TM. This external TM input pin is shared with other functions but will be connected to the internal TM if selected using the TnCK2~TnCK0 bits. The TM input pin can be chosen to have either a rising or falling active edge.

The TMs each have two output pins. When the TM is in the Compare Match Output Mode, these pins can be controlled by the TM to switch to a high or low level or to toggle when a compare match situation occurs. The external TPn output pin is also the pin where the TM generates the PWM output waveform. As the TM output pins are pin-shared with other function, the TM output function must first be setup using registers. A single bit in one of the registers determines if its associated pin is to be used as an external TM output pin or if it is to have another function. The number of output pins for each TM type is different, the details are provided in the accompanying table.

All TM output pin names have an "_n" suffix. Pin names that include a "_0" or "_1" suffix indicate that they are from a TM with multiple output pins. This allows the TM to generate a complimentary output pair, selected using the I/O register data bits.

TM0	TM1	TM2
TP0_0, TP0_1	TP1_0, TP1_1	TP2_0, TP2_1

TM Output Pins

Programming Considerations

The TM Counter Registers, the Capture/Compare CCRA register, being either 16-bit or 10-bit, all have a low and high byte structure. The high bytes can be directly accessed, but as the low bytes can only be accessed via an internal 8-bit buffer, reading or writing to these register pairs must be carried out in a specific way. The important point to note is that data transfer to and from the 8-bit buffer and its related low byte only takes place when a write or read operation to its corresponding high byte is executed.

As the CCRA register is implemented in the way shown in the following diagram and accessing these register pairs is carried out in a specific way described above, it is recommended to use the "MOV" instruction to access the CCRA low byte registers, named TMxAL, using the following access procedures. Accessing the CCRA low byte register without following these access procedures will result in unpredictable values.

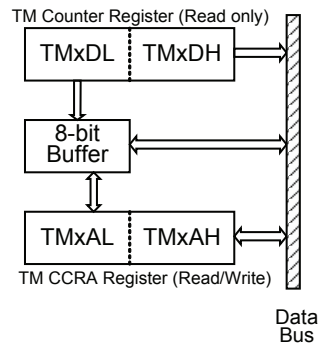

The following steps show the read and write procedures:

- Writing Data to CCRA
 - ♦ Step 1. Write data to Low Byte TMxAL
 - note that here data is only written to the 8-bit buffer.
 - ♦ Step 2. Write data to High Byte TMxAH
 - here data is written directly to the high byte registers and simultaneously data is latched from the 8-bit buffer to the Low Byte registers.
- Reading Data from the Counter Registers and CCRA
 - ♦ Step 1. Read data from the High Byte TMxDH or TMxAH
 - here data is read directly from the High Byte registers and simultaneously data is latched from the Low Byte register into the 8-bit buffer.
 - ♦ Step 2. Read data from the Low Byte TMxDL or TMxAL
 - this step reads data from the 8-bit buffer.

Compact Type TM – CTM

Although the simplest form of the TM types, the Compact TM type still contains three operating modes, which are Compare Match Output, Timer/Event Counter and PWM Output modes. The Compact TM can also be controlled with an external input pin and can drive two external output pins. These two external output pins can be the same signal or the inverse signal.

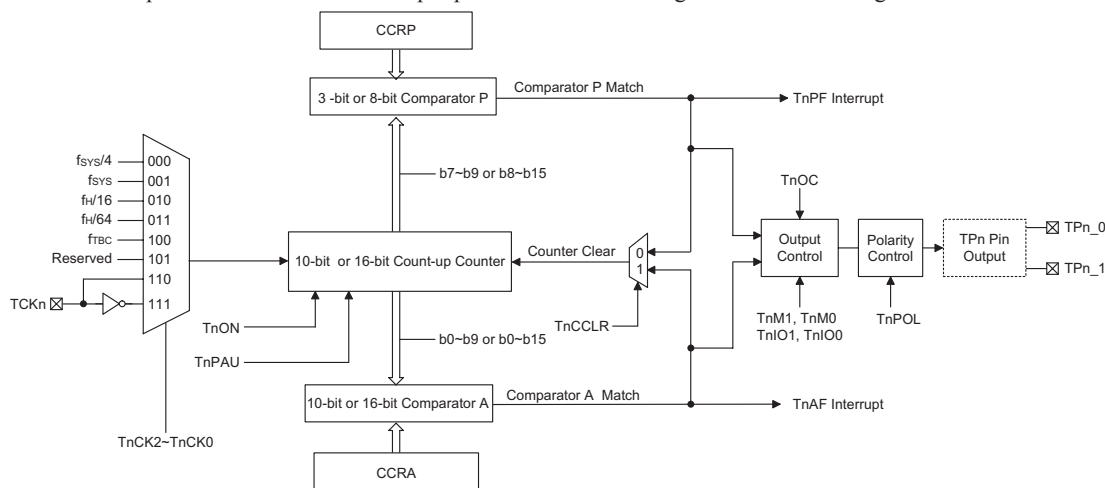

Compact Type TM Block Diagram (n=0, 1)

Compact TM Operation

At its core is a 10-bit or 16-bit count-up counter which is driven by a user selectable internal or external clock source. There are also two internal comparators with the names, Comparator A and Comparator P. These comparators will compare the value in the counter with CCRP and CCRA registers. The CCRP is three bits wide whose value is compared with the highest three bits or eight bits in the counter while the CCRA is the ten bits or sixteen bits and therefore compares with all counter bits.

The only way of changing the value of the 10-bit or 16-bit counter using the application program, is to clear the counter by changing the TnON bit from low to high. The counter will also be cleared automatically by a counter overflow or a compare match with one of its associated comparators. When these conditions occur, a TM interrupt signal will also usually be generated. The Compact Type TM can operate in a number of different operational modes, can be driven by different clock sources including an input pin and can also control an output pin. All operating setup conditions are selected using relevant internal registers.

Compact Type TM Register Description

Overall operation of the Compact TM is controlled using a series of registers. A read only register pair exists to store the internal counter 10-bit or 16-bit value, while a read/write register pair exists to store the internal 10-bit or 16-bit CCRA value. The remaining two registers are control registers which setup the different operating and control modes as well as the three or eight CCRP bits.

Name	Bit 7	Bit 6	Bit 5	Bit 4	Bit 3	Bit 2	Bit 1	Bit 0
TM0C0	T0PAU	T0CK2	T0CK1	T0CK0	T0ON	T0RP2	T0RP1	T0RP0
TM0C1	T0M1	T0M0	T0IO1	T0IO0	T0OC	T0POL	T0DPX	T0CCLR
TM0DL	D7	D6	D5	D4	D3	D2	D1	D0
TM0DH	—	—	—	—	—	—	D9	D8
TM0AL	D7	D6	D5	D4	D3	D2	D1	D0
TM0AH	—	—	—	—	—	—	D9	D8

10-bit Compact TM Register List

Name	Bit 7	Bit 6	Bit 5	Bit 4	Bit 3	Bit 2	Bit 1	Bit 0
TM1C0	T1PAU	T1CK2	T1CK1	T1CK0	T1ON	—	—	—
TM1C1	T1M1	T1M0	T1IO1	T1IO0	T1OC	T1POL	T1DPX	T1CCLR
TM1DL	D7	D6	D5	D4	D3	D2	D1	D0
TM1DH	D15	D14	D13	D12	D11	D10	D9	D8
TM1AL	D7	D6	D5	D4	D3	D2	D1	D0
TM1AH	D15	D14	D13	D12	D11	D10	D9	D8
TM1RP	D7	D6	D5	D4	D3	D2	D1	D0

16-bit Compact TM Register List

TM0DL Register – 10-bit CTM

Bit	7	6	5	4	3	2	1	0
Name	D7	D6	D5	D4	D3	D2	D1	D0
R/W	R	R	R	R	R	R	R	R
POR	0	0	0	0	0	0	0	0

Bit 7~0 **TM0DL**: TM0 Counter Low Byte Register bit 7~bit 0
TM0 10-bit Counter bit 7~bit 0

TM0DH Register – 10-bit CTM

Bit	7	6	5	4	3	2	1	0
Name	—	—	—	—	—	—	D9	D8
R/W	—	—	—	—	—	—	R	R
POR	—	—	—	—	—	—	0	0

Bit 7~2 Unimplemented, read as "0"
Bit 1~0 **TM0DH**: TM0 Counter High Byte Register bit 1~bit 0
TM0 10-bit Counter bit 9~bit 8

TM0AL Register(n=0) – 10-bit CTM

Bit	7	6	5	4	3	2	1	0
Name	D7	D6	D5	D4	D3	D2	D1	D0
R/W	R/W	R/W	R/W	R/W	R/W	R/W	R/W	R/W
POR	0	0	0	0	0	0	0	0

Bit 7~0 **TM0AL**: TM0 CCRA Low Byte Register bit 7~bit 0
TM0 10-bit CCRA bit 7~bit 0

TM0AH Register – 10-bit CTM

Bit	7	6	5	4	3	2	1	0
Name	—	—	—	—	—	—	D9	D8
R/W	—	—	—	—	—	—	R/W	R/W
POR	—	—	—	—	—	—	0	0

Bit 7~2 Unimplemented, read as "0"

Bit 1~0 **TM0AH:** TM0 CCRA High Byte Register bit 1~bit 0
 TM0 10-bit CCRA bit 9~bit 8

TM1DL Register – 16-bit CTM

Bit	7	6	5	4	3	2	1	0
Name	D7	D6	D5	D4	D3	D2	D1	D0
R/W	R	R	R	R	R	R	R	R
POR	0	0	0	0	0	0	0	0

Bit 7~0 **TM1DL:** TM1 Counter Low Byte Register bit 7~bit 0
 TM1 16-bit Counter bit 7~bit 0

TM1DH Register – 16-bit CTM

Bit	7	6	5	4	3	2	1	0
Name	D7	D6	D5	D4	D3	D2	D1	D0
R/W	R	R	R	R	R	R	R	R
POR	0	0	0	0	0	0	0	0

Bit 7~0 **TM1DH:** TM1 Counter High Byte Register bit 7~bit 0
 TM1 16-bit Counter bit 15~bit 8

TM1AL Register – 16-bit CTM

Bit	7	6	5	4	3	2	1	0
Name	D7	D6	D5	D4	D3	D2	D1	D0
R/W	R/W	R/W	R/W	R/W	R/W	R/W	R/W	R/W
POR	0	0	0	0	0	0	0	0

Bit 7~0 **TM1AL:** TM1 CCRA Low Byte Register bit 7~bit 0
 TM1 16-bit CCRA bit 7~bit 0

TM1AH Register – 16-bit CTM

Bit	7	6	5	4	3	2	1	0
Name	D7	D6	D5	D4	D3	D2	D1	D0
R/W	R/W	R/W	R/W	R/W	R/W	R/W	R/W	R/W
POR	0	0	0	0	0	0	0	0

Bit 7~0 **TM1AH:** TM1 CCRA High Byte Register bit 7~bit 0
 TM1 16-bit CCRA bit 15~bit 8

TM0C0 Register – 10-bit CTM

Bit	7	6	5	4	3	2	1	0
Name	T0PAU	T0CK2	T0CK1	T0CK0	T0ON	T0RP2	T0RP1	T0RP0
R/W	R/W	R/W	R/W	R/W	R/W	R/W	R/W	R/W
POR	0	0	0	0	0	0	0	0

- Bit 7 T0PAU:** TM0 Counter Pause Control
 0: Run
 1: Pause
 The counter can be paused by setting this bit high. Clearing the bit to zero restores normal counter operation. When in a Pause condition the TM will remain powered up and continue to consume power. The counter will retain its residual value when this bit changes from low to high and resume counting from this value when the bit changes to a low value again.
- Bit 6~4 T0CK2~T0CK0:** Select TM0 Counter clock
 000: $f_{SYS}/4$
 001: f_{SYS}
 010: $f_H/16$
 011: $f_H/64$
 100: f_{TBC}
 101: Reserved
 110: TCK0 rising edge clock
 111: TCK0 falling edge clock
 These three bits are used to select the clock source for the TM0. Selecting the Reserved clock input will effectively disable the internal counter. The external pin clock source can be chosen to be active on the rising or falling edge. The clock source f_{SYS} is the system clock, while f_H and f_{TBC} are other internal clocks, the details of which can be found in the oscillator section.
- Bit 3 T0ON:** TM0 Counter On/Off Control
 0: Off
 1: On
 This bit controls the overall on/off function of the TM0. Setting the bit high enables the counter to run, clearing the bit disables the TM0. Clearing this bit to zero will stop the counter from counting and turn off the TM0 which will reduce its power consumption. When the bit changes state from low to high the internal counter value will be reset to zero, however when the bit changes from high to low, the internal counter will retain its residual value. If the TM0 is in the Compare Match Output Mode then the TM0 output pin will be reset to its initial condition, as specified by the T0OC bit, when the T0ON bit changes from low to high.
- Bit 2~0 T0RP2~T0RP0:** TM0 CCRP 3-bit register, compared with the TM0 Counter bit 9~bit 7 Comparator P Match Period
 000: 1024 TM0 clocks
 001: 128 TM0 clocks
 010: 256 TM0 clocks
 011: 384 TM0 clocks
 100: 512 TM0 clocks
 101: 640 TM0 clocks
 110: 768 TM0 clocks
 111: 896 TM0 clocks
 These three bits are used to setup the value on the internal CCRP 3-bit register, which are then compared with the internal counter's highest three bits. The result of this comparison can be selected to clear the internal counter if the T0CCLR bit is set to zero. Setting the T0CCLR bit to zero ensures that a compare match with the CCRP values will reset the internal counter. As the CCRP bits are only compared with the highest three counter bits, the compare values exist in 128 clock cycle multiples. Clearing all three bits to zero is in effect allowing the counter to overflow at its maximum value.

TM0C1 Register – 10-bit CTM

Bit	7	6	5	4	3	2	1	0
Name	T0M1	T0M0	T0IO1	T0IO0	T0OC	T0POL	T0DPX	T0CCLR
R/W	R/W	R/W	R/W	R/W	R/W	R/W	R/W	R/W
POR	0	0	0	0	0	0	0	0

Bit 7~6 **T0M1~T0M0:** Select TM0 Operating Mode

- 00: Compare Match Output Mode
- 01: Undefined
- 10: PWM Mode
- 11: Timer/Counter Mode

These bits setup the required operating mode for the TM. To ensure reliable operation the TM should be switched off before any changes are made to the T0M1 and T0M0 bits. In the Timer/Counter Mode, the TM output pin control must be disabled.

Bit 5~4 **T0IO1~T0IO0:** Select TP0_0, TP0_1 output function

Compare Match Output Mode

- 00: No change
- 01: Output low
- 10: Output high
- 11: Toggle output

PWM Mode

- 00: PWM Output inactive state
- 01: PWM Output active state
- 10: PWM output
- 11: Undefined

Timer/counter Mode

unused

These two bits are used to determine how the TM0 output pin changes state when a certain condition is reached. The function that these bits select depends upon in which mode the TM0 is running.

In the Compare Match Output Mode, the T0IO1 and T0IO0 bits determine how the TM0 output pin changes state when a compare match occurs from the Comparator A. The TM0 output pin can be setup to switch high, switch low or to toggle its present state when a compare match occurs from the Comparator A. When the bits are both zero, then no change will take place on the output. The initial value of the TM0 output pin should be setup using the T0OC bit in the TM0C1 register. Note that the output level requested by the T0IO1 and T0IO0 bits must be different from the initial value setup using the T0OC bit otherwise no change will occur on the TM0 output pin when a compare match occurs. After the TM0 output pin changes state it can be reset to its initial level by changing the level of the T0ON bit from low to high.

In the PWM Mode, the T0IO1 and T0IO0 bits determine how the TM output pin changes state when a certain compare match condition occurs. The PWM output function is modified by changing these two bits. It is necessary to only change the values of the T0IO1 and T0IO0 bits only after the TM0 has been switched off. Unpredictable PWM outputs will occur if the T0IO1 and T0IO0 bits are changed when the TM is running.

- Bit 3 **T0OC:** TP0_0, TP0_1 Output control bit
Compare Match Output Mode
 0: Initial low
 1: Initial high
PWM Mode
 0: Active low
 1: Active high
This is the output control bit for the TM0 output pin. Its operation depends upon whether TM0 is being used in the Compare Match Output Mode or in the PWM Mode. It has no effect if the TM0 is in the Timer/Counter Mode. In the Compare Match Output Mode it determines the logic level of the TM0 output pin before a compare match occurs. In the PWM Mode it determines if the PWM signal is active high or active low.
- Bit 2 **T0POL:** TP0_0, TP0_1 Output polarity Control
 0: Non-invert
 1: Invert
This bit controls the polarity of the TP0_0 or TP0_1 output pin. When the bit is set high the TM0 output pin will be inverted and not inverted when the bit is zero. It has no effect if the TM0 is in the Timer/Counter Mode.
- Bit 1 **T0DPX:** TM0 PWM period/duty Control
 0: CCRP - period; CCRA - duty
 1: CCRP - duty; CCRA - period
This bit, determines which of the CCRA and CCRP registers are used for period and duty control of the PWM waveform.
- Bit 0 **T0CCLR:** Select TM0 Counter clear condition
 0: TM0 Comparator P match
 1: TM0 Comparator A match
This bit is used to select the method which clears the counter. Remember that the Compact TM0 contains two comparators, Comparator A and Comparator P, either of which can be selected to clear the internal counter. With the T0CCLR bit set high, the counter will be cleared when a compare match occurs from the Comparator A. When the bit is low, the counter will be cleared when a compare match occurs from the Comparator P or with a counter overflow. A counter overflow clearing method can only be implemented if the CCRP bits are all cleared to zero. The T0CCLR bit is not used in the PWM Mode.

TM1C0 Register – 16-bit CTM

Bit	7	6	5	4	3	2	1	0
Name	T1PAU	T1CK2	T1CK1	T1CK0	T1ON	—	—	—
R/W	R/W	R/W	R/W	R/W	R/W	—	—	—
POR	0	0	0	0	0	—	—	—

- Bit 7** **T1PAU:** TM1 Counter Pause Control
0: Run
1: Pause
The counter can be paused by setting this bit high. Clearing the bit to zero restores normal counter operation. When in a Pause condition the TM will remain powered up and continue to consume power. The counter will retain its residual value when this bit changes from low to high and resume counting from this value when the bit changes to a low value again.
- Bit 6~4** **T1CK2~T1CK0:** Select TM1 Counter clock
000: $f_{SYS}/4$
001: f_{SYS}
010: $f_H/16$
011: $f_H/64$
100: f_{TBC}
101: Reserved
110: TCK1 rising edge clock
111: TCK1 falling edge clock
These three bits are used to select the clock source for the TM1. Selecting the Reserved clock input will effectively disable the internal counter. The external pin clock source can be chosen to be active on the rising or falling edge. The clock source f_{SYS} is the system clock, while f_H and f_{TBC} are other internal clocks, the details of which can be found in the oscillator section.
- Bit 3** **T1ON:** TM1 Counter On/Off Control
0: Off
1: On
This bit controls the overall on/off function of the TM1. Setting the bit high enables the counter to run, clearing the bit disables the TM1. Clearing this bit to zero will stop the counter from counting and turn off the TM1 which will reduce its power consumption. When the bit changes state from low to high the internal counter value will be reset to zero, however when the bit changes from high to low, the internal counter will retain its residual value. If the TM1 is in the Compare Match Output Mode then the TM1 output pin will be reset to its initial condition, as specified by the T1OC bit, when the T1ON bit changes from low to high.
- Bit 2~0** Unimplemented, read as "0"

TM1C1 Register – 16-bit CTM

Bit	7	6	5	4	3	2	1	0
Name	T1M1	T1M0	T1IO1	T1IO0	T1OC	T1POL	T1DPX	T1CCLR
R/W	R/W	R/W	R/W	R/W	R/W	R/W	R/W	R/W
POR	0	0	0	0	0	0	0	0

Bit 7~6 **T1M1~T1M0:** Select TM1 Operating Mode

- 00: Compare Match Output Mode
- 01: Undefined
- 10: PWM Mode
- 11: Timer/Counter Mode

These bits setup the required operating mode for the TM. To ensure reliable operation the TM should be switched off before any changes are made to the T1M1 and T1M0 bits. In the Timer/Counter Mode, the TM output pin control must be disabled.

Bit 5~4 **T1IO1~T1IO0:** Select TP1_0, TP1_1 output function

Compare Match Output Mode

- 00: No change
- 01: Output low
- 10: Output high
- 11: Toggle output

PWM Mode

- 00: PWM output inactive state
- 01: PWM output active state
- 10: PWM output
- 11: Undefined

Timer/counter Mode

unused

These two bits are used to determine how the TM1 output pin changes state when a certain condition is reached. The function that these bits select depends upon in which mode the TM1 is running.

In the Compare Match Output Mode, the T1IO1 and T1IO0 bits determine how the TM1 output pin changes state when a compare match occurs from the Comparator A. The TM1 output pin can be setup to switch high, switch low or to toggle its present state when a compare match occurs from the Comparator A. When the bits are both zero, then no change will take place on the output. The initial value of the TM1 output pin should be setup using the T1OC bit in the TM1C1 register. Note that the output level requested by the T1IO1 and T1IO0 bits must be different from the initial value setup using the T1OC bit otherwise no change will occur on the TM1 output pin when a compare match occurs. After the TM1 output pin changes state it can be reset to its initial level by changing the level of the T1ON bit from low to high.

In the PWM Mode, the T1IO1 and T1IO0 bits determine how the TM output pin changes state when a certain compare match condition occurs. The PWM output function is modified by changing these two bits. It is necessary to only change the values of the T1IO1 and T1IO0 bits only after the TM1 has been switched off. Unpredictable PWM outputs will occur if the T1IO1 and T1IO0 bits are changed when the TM is running.

- Bit 3 **TIOC:** TP1_0, TP1_1 Output control bit
 Compare Match output Mode
 0: Initial low
 1: Initial high
 PWM Mode
 0: Active low
 1: Active high
- This is the output control bit for the TM1 output pin. Its operation depends upon whether TM1 is being used in the Compare Match Output Mode or in the PWM Mode. It has no effect if the TM1 is in the Timer/Counter Mode. In the Compare Match Output Mode it determines the logic level of the TM1 output pin before a compare match occurs. In the PWM Mode it determines if the PWM signal is active high or active low.
- Bit 2 **TIPOL:** TP1_0, TP1_1 output polarity Control
 0: Non-invert
 1: Invert
- This bit controls the polarity of the TP1_0 or TP1_1 output pin. When the bit is set high the TM1 output pin will be inverted and not inverted when the bit is zero. It has no effect if the TMn is in the Timer/Counter Mode.
- Bit 1 **TIDPX:** TM1 PWM period/duty Control
 0: CCRP - period; CCRA - duty
 1: CCRP - duty; CCRA - period
- This bit, determines which of the CCRA and CCRP registers are used for period and duty control of the PWM waveform.
- Bit 0 **TICCLR:** Select TM1 Counter clear condition
 0: TM1 Comparator P match
 1: TM1 Comparator A match
- This bit is used to select the method which clears the counter. Remember that the Compact TM1 contains two comparators, Comparator A and Comparator P, either of which can be selected to clear the internal counter. With the TICCLR bit set high, the counter will be cleared when a compare match occurs from the Comparator A. When the bit is low, the counter will be cleared when a compare match occurs from the Comparator P or with a counter overflow. A counter overflow clearing method can only be implemented if the CCRP bits are all cleared to zero. The TICCLR bit is not used in the PWM Mode.

TM1RP Register – 16-bit CTM

Bit	7	6	5	4	3	2	1	0
Name	D7	D6	D5	D4	D3	D2	D1	D0
R/W	R/W	R/W	R/W	R/W	R/W	R/W	R/W	R/W
POR	0	0	0	0	0	0	0	0

- Bit 7~0 **TM1RP:** TM1 CCRP Register bit 7~bit 0
 0: 65536 TM1 clocks
 1~255: 256×(1~255)TM1 clocks
- TM1 CCRP 8-bit register, compared with the TM1 Counter bit 15~bit 8 Comparator P Match Period
- These three bits are used to setup the value on the internal CCRP 8-bit register, which are then compared with the internal counter's highest eight bits. The result of this comparison can be selected to clear the internal counter if the TICCLR bit is set to zero. Setting the TICCLR bit to zero ensures that a compare match with the CCRP values will reset the internal counter. As the CCRP bits are only compared with the highest eight counter bits, the compare values exist in 256 clock cycle multiples. Clearing all three bits to zero is in effect allowing the counter to overflow at its maximum value.

Compact Type TM Operating Modes

The Compact Type TM can operate in one of three operating modes, Compare Match Output Mode, PWM Mode or Timer/Counter Mode. The operating mode is selected using the TnM1 and TnM0 bits in the TMnC1 register.

Compare Match Output Mode

To select this mode, bits TnM1 and TnM0 in the TMnC1 register, should be set to "00" respectively. In this mode once the counter is enabled and running it can be cleared by three methods. These are a counter overflow, a compare match from Comparator A and a compare match from Comparator P. When the TnCCLR bit is low, there are two ways in which the counter can be cleared. One is when a compare match occurs from Comparator P, the other is when the CCRP bits are all zero which allows the counter to overflow. Here both TnAF and TnPF interrupt request flags for the Comparator A and Comparator P respectively, will both be generated.

If the TnCCLR bit in the TMnC1 register is high then the counter will be cleared when a compare match occurs from Comparator A. However, here only the TnAF interrupt request flag will be generated even if the value of the CCRP bits is less than that of the CCRA registers. Therefore when TnCCLR is high no TnPF interrupt request flag will be generated. If the CCRA bits are all zero, the counter will overflow when it reaches its maximum 10-bit, 3FF Hex, or 16-bit, FFFF Hex, value, however here the TnAF interrupt request flag will not be generated.

As the name of the mode suggests, after a comparison is made, the TM output pin will change state. The TM output pin condition however only changes state when a TnAF interrupt request flag is generated after a compare match occurs from Comparator A. The TnPF interrupt request flag, generated from a compare match occurs from Comparator P, will have no effect on the TM output pin. The way in which the TM output pin changes state are determined by the condition of the TnIO1 and TnIO0 bits in the TMnC1 register. The TM output pin can be selected using the TnIO1 and TnIO0 bits to go high, to go low or to toggle from its present condition when a compare match occurs from Comparator A. The initial condition of the TM output pin, which is setup after the TnON bit changes from low to high, is setup using the TnOC bit. Note that if the TnIO1 and TnIO0 bits are zero then no pin change will take place.

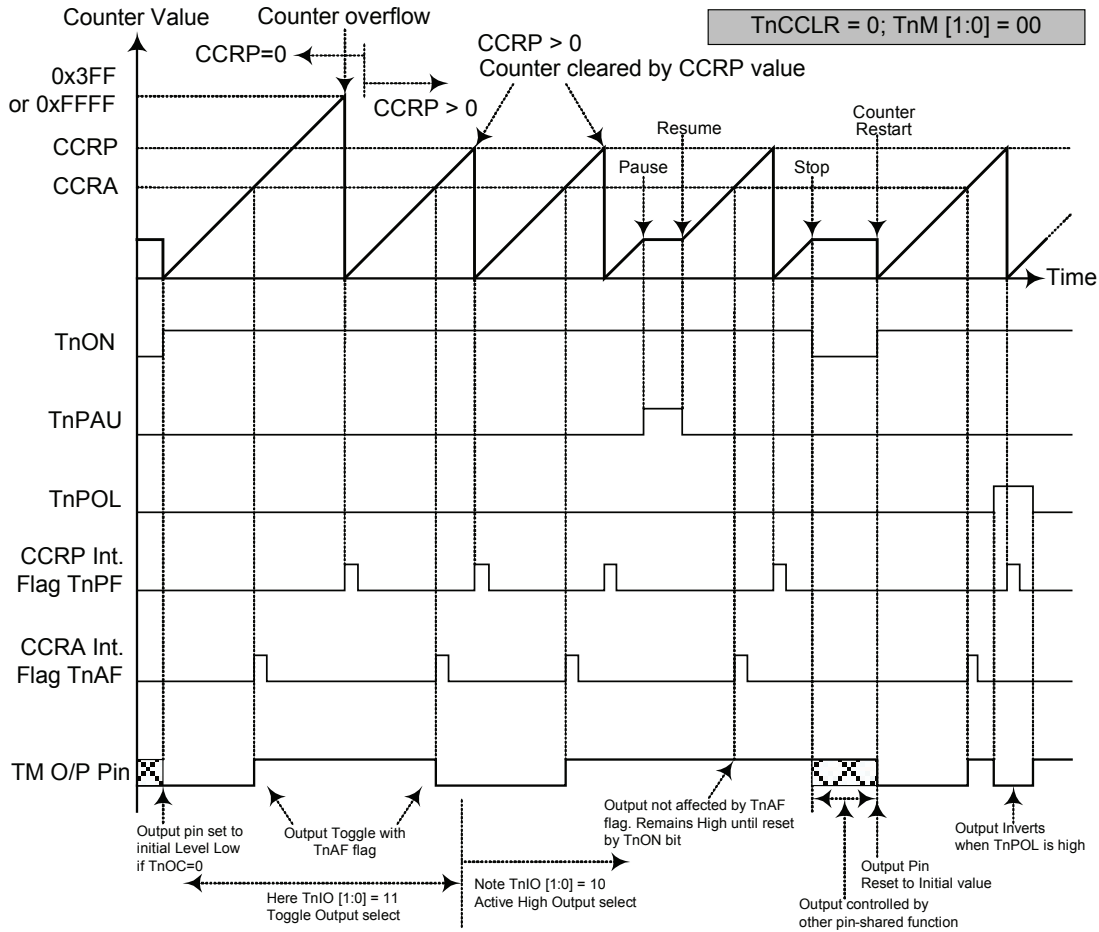

Compare Match Output Mode – TnCCLR=0

- Note: 1. With TnCCLR=0, a Comparator P match will clear the counter
 2. The TM output pin is controlled only by the TnAf flag
 3. The output pin is reset to its initial state by a TnON bit rising edge
 4. n=0, 1

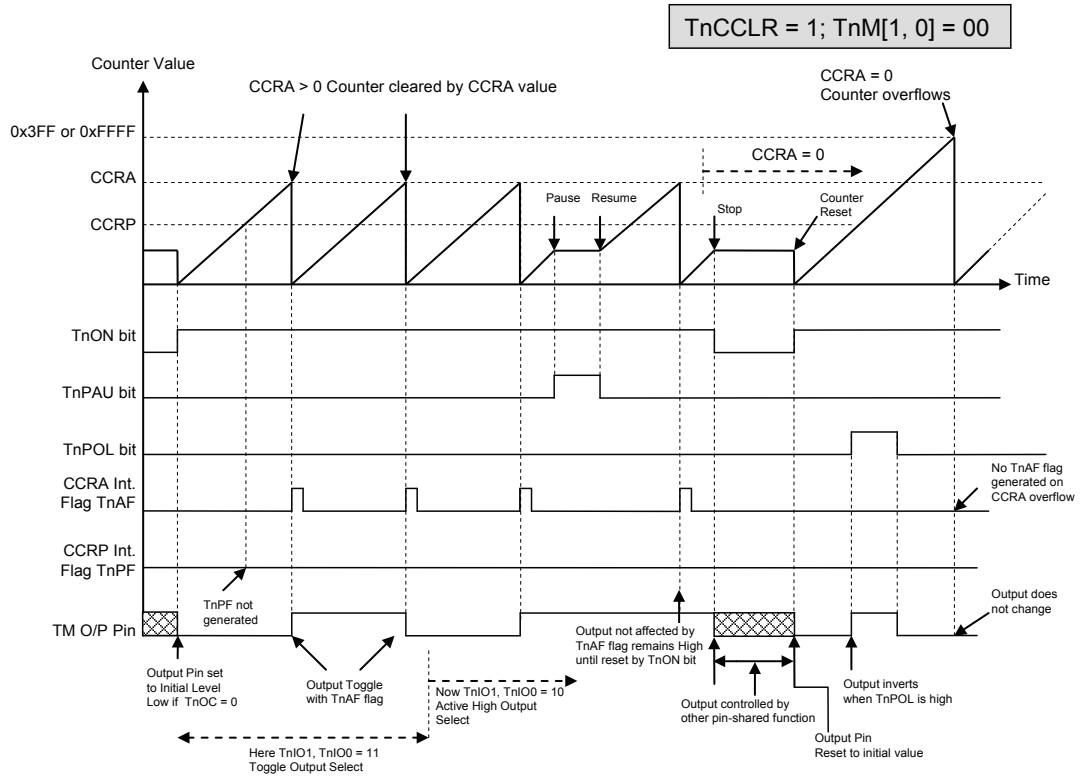

Compare Match Output Mode – TnCCLR=1

- Note:
1. With $TnCCLR=1$, a Comparator A match will clear the counter
 2. The TM output pin is controlled only by the TnAF flag
 3. The output pin is reset to its initial state by a TnON bit rising edge
 4. The TnPF flag is not generated when $TnCCLR=1$
 5. $n=0, 1$

Timer/Counter Mode

To select this mode, bits TnM1 and TnM0 in the TMnC1 register should be set to 11 respectively. The Timer/Counter Mode operates in an identical way to the Compare Match Output Mode generating the same interrupt flags. The exception is that in the Timer/Counter Mode the TM output pin is not used. Therefore the above description and Timing Diagrams for the Compare Match Output Mode can be used to understand its function. As the TM output pin is not used in this mode, the pin can be used as a normal I/O pin or other pin-shared function.

PWM Output Mode

To select this mode, bits TnM1 and TnM0 in the TMnC1 register should be set to 10 respectively. The PWM function within the TM is useful for applications which require functions such as motor control, heating control, illumination control etc. By providing a signal of fixed frequency but of varying duty cycle on the TM output pin, a square wave AC waveform can be generated with varying equivalent DC RMS values.

As both the period and duty cycle of the PWM waveform can be controlled, the choice of generated waveform is extremely flexible. In the PWM mode, the TnCCLR bit has no effect on the PWM operation. Both of the CCRA and CCRP registers are used to generate the PWM waveform, one register is used to clear the internal counter and thus control the PWM waveform frequency, while the other one is used to control the duty cycle. Which register is used to control either frequency or duty cycle is determined using the TnDPX bit in the TMnC1 register. The PWM waveform frequency and duty cycle can therefore be controlled by the values in the CCRA and CCRP registers.

An interrupt flag, one for each of the CCRA and CCRP, will be generated when a compare match occurs from either Comparator A or Comparator P. The TnOC bit in the TMnC1 register is used to select the required polarity of the PWM waveform while the two TnIO1 and TnIO0 bits are used to enable the PWM output or to force the TM output pin to a fixed high or low level. The TnPOL bit is used to reverse the polarity of the PWM output waveform.

10-bit CTM, PWM Mode, Edge-aligned Mode, T0DPX=0

CCRP	001b	010b	011b	100b	101b	110b	111b	000b
Period	128	256	384	512	640	768	896	1024
Duty	CCRA							

If $f_{SYS}=16\text{MHz}$, TM clock source is $f_{SYS}/4$, CCRP=100b and CCRA=128,

The CTM PWM output frequency= $(f_{SYS}/4)/512=f_{SYS}/2048=7.8125\text{ kHz}$, duty= $128/512=25\%$.

If the Duty value defined by the CCRA register is equal to or greater than the Period value, then the PWM output duty is 100%.

10-bit CTM, PWM Mode, Edge-aligned Mode, T0DPX=1

CCRP	001b	010b	011b	100b	101b	110b	111b	000b
Period	CCRA							
Duty	128	256	384	512	640	768	896	1024

The PWM output period is determined by the CCRA register value together with the TM clock while the PWM duty cycle is defined by the CCRP register value.

16-bit CTM, PWM Mode, Edge-aligned Mode, T1DPX=0

CCRP	1~255	0
Period	CCRP×256	65536
Duty	CCRA	

If $f_{SYS}=16\text{MHz}$, TM clock source is $f_{SYS}/4$, CCRP=2 and CCRA=128,

The CTM PWM output frequency= $(f_{SYS}/4)/(2\times 256)=f_{SYS}/2048=7.8125\text{ kHz}$, duty= $128/(2\times 256)=25\%$.

If the Duty value defined by the CCRA register is equal to or greater than the Period value, then the PWM output duty is 100%.

16-bit CTM, PWM Mode, Edge-aligned Mode, T1DPX=1

CCRP	1~255	0
Period	CCRA	
Duty	CCRP×256	65536

The PWM output period is determined by the CCRA register value together with the TM clock while the PWM duty cycle is defined by the (CCRP×256) except when the CCRP value is equal to 0.

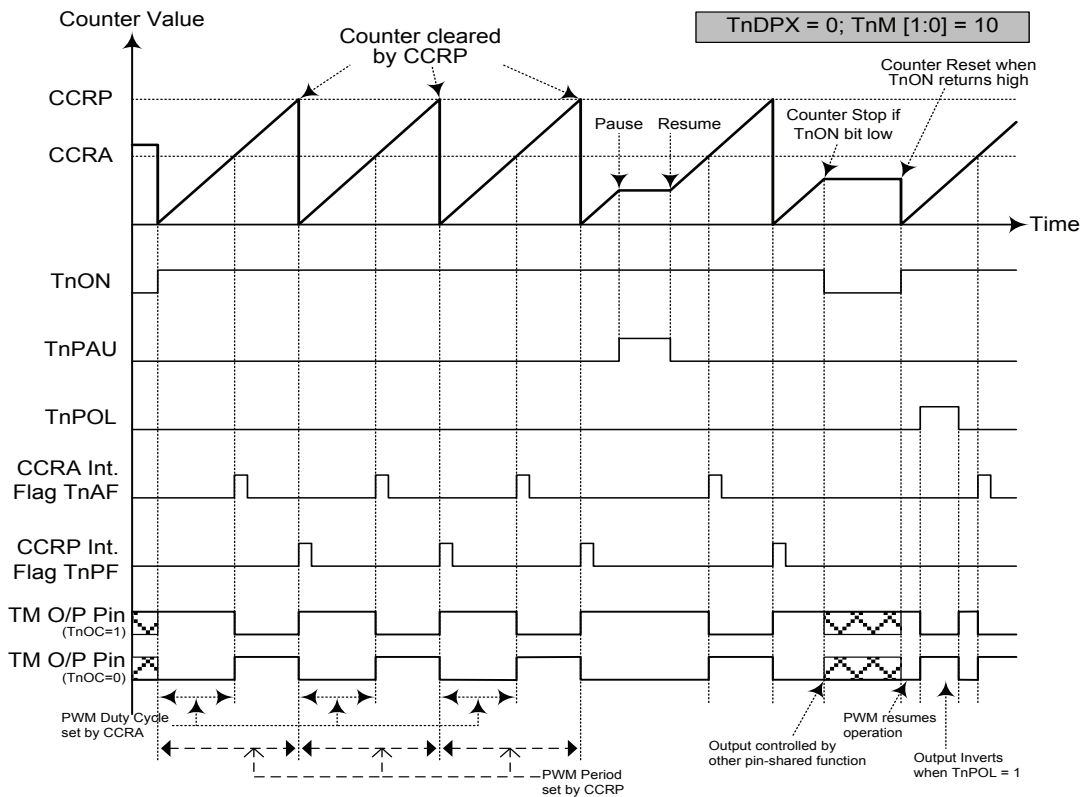

PWM Mode – TnDPX=0

- Note: 1. Here TnDPX=0 – Counter cleared by CCRP
 2. A counter clear sets the PWM Period
 3. The internal PWM function continues even when TnIO [1:0]=00 or 01
 4. The TnCCLR bit has no influence on PWM operation
 5. n=0, 1

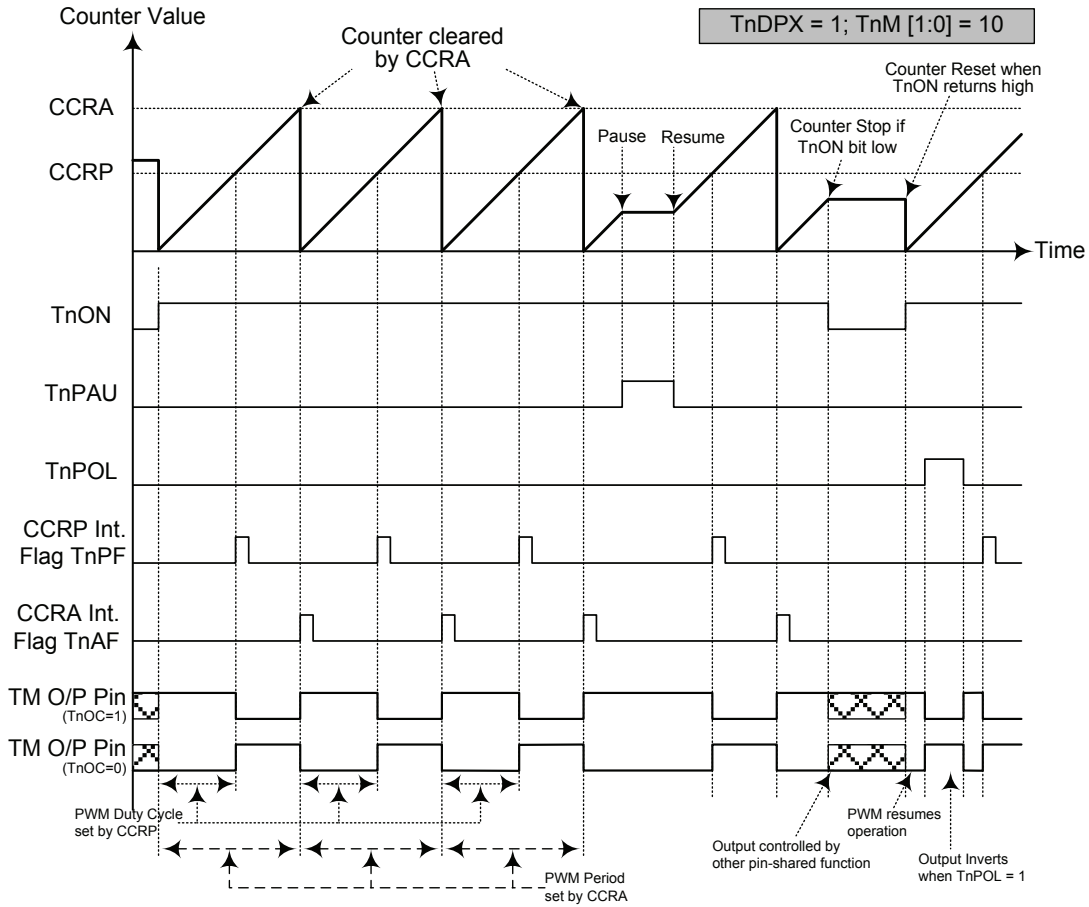

PWM Mode – TnDPX=1

- Note: 1. Here TnDPX=1 – Counter cleared by CCRA
 2. A counter clear sets the PWM Period
 3. The internal PWM function continues even when TnIO [1:0]=00 or 01
 4. The TnCCLR bit has no influence on PWM operation
 5. n=0, 1

Buzzer Control

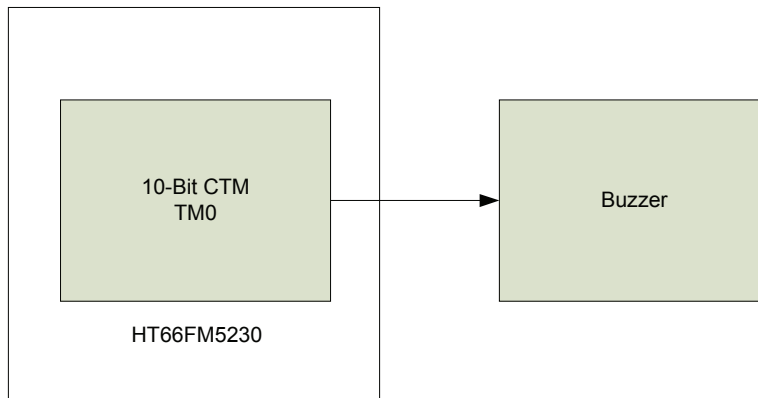

The 10-bit CTM can drive an external buzzer using its PWM mode to provide volume control.

Standard Type TM – STM

The Standard Type TM contains five operating modes, which are Compare Match Output, Timer/Event Counter, Capture Input, Single Pulse Output and PWM Output modes. The Standard TM can also be controlled with an external input pin and can drive two external output pins.

Name	TM No.	TM Input Pin	TM Output Pin
10-bit STM	2	TCK2	TP2_0, TP2_1

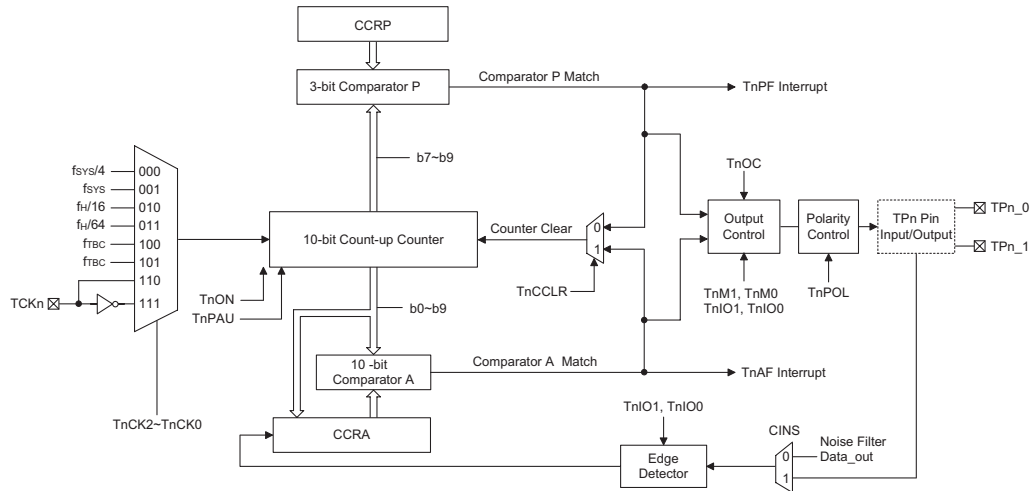

Standard Type TM Block Diagram (n=2)

The 10-bit STM can capture the Noise Fliter Dat_Out signal time between the raising edge and falling edge.

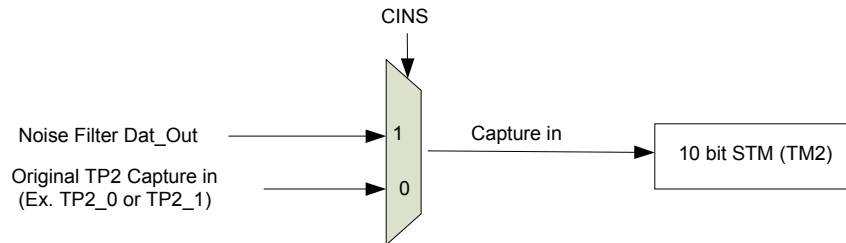

TM2 in Capture Mode Signal Select

Standard TM Operation

At its core is a 10-bit count-up counter which is driven by a user selectable internal or external clock source. There are also two internal comparators with the names, Comparator A and Comparator P. These comparators will compare the value in the counter with CCRP and CCRA registers. The CCRP is 3-bits wide whose value is compared with the highest 3 bits in the counter while the CCRA is the 10 bits and therefore compares with all counter bits.

The only way of changing the value of the 10-bit counter using the application program, is to clear the counter by changing the T2ON bit from low to high. The counter will also be cleared automatically by a counter overflow or a compare match with one of its associated comparators. When these conditions occur, a TM interrupt signal will also usually be generated. The Standard Type TM can operate in a number of different operational modes, can be driven by different clock sources including an input pin and can also control an output pin. All operating setup conditions are selected using relevant internal registers.

Standard Type TM Register Description

Overall operation of the Standard TM is controlled using a series of registers. A read only register pair exists to store the internal counter 10-bit value, while a read/write register pair exists to store the internal 10-bit CCRA value. The remaining two registers are control registers which setup the different operating and control modes as well as the three CCRP bits.

Name	Bit 7	Bit 6	Bit 5	Bit 4	Bit 3	Bit 2	Bit 1	Bit 0
TM2C0	T2PAU	T2CK2	T2CK1	T2CK0	T2ON	T2RP2	T2PR1	T2PR0
TM2C1	T2M1	T2M0	T2IO1	T2IO0	T2OC	T2POL	T2DPX	T2CCLR
TM2DL	D7	D6	D5	D4	D3	D2	D1	D0
TM2DH	—	—	—	—	—	—	D9	D8
TM2AL	D7	D6	D5	D4	D3	D2	D1	D0
TM2AH	—	—	—	—	—	—	D9	D8

10-bit Standard TM Register List

TM2C0 Register – 10-bit STM

Bit	7	6	5	4	3	2	1	0
Name	T2PAU	T2CK2	T2CK1	T2CK0	T2ON	T2RP2	T2PR1	T2PR0
R/W	R/W	R/W	R/W	R/W	R/W	R/W	R/W	R/W
POR	0	0	0	0	0	0	0	0

Bit 7 **T2PAU:** TM2 Counter Pause Control

0: Run
1: Pause

The counter can be paused by setting this bit high. Clearing the bit to zero restores normal counter operation. When in a Pause condition the TM will remain powered up and continue to consume power. The counter will retain its residual value when this bit changes from low to high and resume counting from this value when the bit changes to a low value again.

Bit 6~4 **T2CK2~T2CK0:** Select TM2 Counter clock

000: $f_{SYS}/4$
001: f_{SYS}
010: $f_H/16$
011: $f_H/64$
100: f_{TBC}
101: f_{TBC}
110: TCK2 rising edge clock
111: TCK2 falling edge clock

These three bits are used to select the clock source for the TM2. The external pin clock source can be chosen to be active on the rising or falling edge. The clock source f_{SYS} is the system clock, while f_H and f_{SUB} are other internal clocks, the details of which can be found in the oscillator section.

Bit 3 **T2ON:** TM2 Counter On/Off Control

0: Off
1: On

This bit controls the overall on/off function of the TM2. Setting the bit high enables the counter to run, clearing the bit disables the TM2. Clearing this bit to zero will stop the counter from counting and turn off the TM2 which will reduce its power consumption. When the bit changes state from low to high the internal counter value will be reset to zero, however when the bit changes from high to low, the internal counter will retain its residual value until the bit returns high again. If the TM2 is in the Compare Match Output Mode then the TM2 output pin will be reset to its initial condition, as specified by the T2OC bit, when the T2ON bit changes from low to high.

Bit 2~0 **T2RP2~T2RP0:** TM2 CCRP 3-bit register, compared with the TM2 Counter bit 9~bit 7
 Comparator P Match Period
 000: 1024 TM2 clocks
 001: 128 TM2 clocks
 010: 256 TM2 clocks
 011: 384 TM2 clocks
 100: 512 TM2 clocks
 101: 640 TM2 clocks
 110: 768 TM2 clocks
 111: 896 TM2 clocks

These three bits are used to setup the value on the internal CCRP 3-bit register, which are then compared with the internal counter's highest three bits. The result of this comparison can be selected to clear the internal counter if the T2CCLR bit is set to zero. Setting the T2CCLR bit to zero ensures that a compare match with the CCRP values will reset the internal counter. As the CCRP bits are only compared with the highest three counter bits, the compare values exist in 128 clock cycle multiples. Clearing all three bits to zero is in effect allowing the counter to overflow at its maximum value

TM2C1 Register – 10-bit STM

Bit	7	6	5	4	3	2	1	0
Name	T2M1	T2M0	T2IO1	T2IO0	T2OC	T2POL	T2DPX	T2CCLR
R/W	R/W	R/W	R/W	R/W	R/W	R/W	R/W	R/W
POR	0	0	0	0	0	0	0	0

Bit 7~6 **T2M1~T2M0:** Select TM2 Operating Mode
 00: Compare Match Output Mode
 01: Capture Input Mode
 10: PWM Mode or Single Pulse Output Mode
 11: Timer/Counter Mode

These bits setup the required operating mode for the TM. To ensure reliable operation the TM should be switched off before any changes are made to the T2M1 and T2M0 bits. In the Timer/Counter Mode, the TM output pin control must be disabled.

Bit 5~4 **T2IO1~T2IO0:** Select TP2_0, TP2_1 output function

Compare Match Output Mode
 00: No change
 01: Output low
 10: Output high
 11: Toggle output

PWM Mode /Single Pulse Output Mode
 00: PWM Output inactive state
 01: PWM Output active state
 10: PWM output
 11: Single pulse output

Capture Input Mode
 00: Input capture at rising edge of TP2_0, TP2_1
 01: Input capture at falling edge of TP2_0, TP2_1
 10: Input capture at falling/rising edge of TP2_0, TP2_1
 11: Input capture disabled

Timer/counter Mode
 unused

These two bits are used to determine how the TM2 output pin changes state when a certain condition is reached. The function that these bits select depends upon in which mode the TM2 is running.

In the Compare Match Output Mode, the T2IO1 and T2IO0 bits determine how the TM2 output pin changes state when a compare match occurs from the Comparator A. The TM2 output pin can be setup to switch high, switch low or to toggle its present state when a compare match occurs from the Comparator A. When the bits are both zero, then no change will take place on the output. The initial value of the TM2 output pin should be setup using the T2OC bit in the TM2C1 register. Note that the output level requested by the T2IO1 and T2IO0 bits must be different from the initial value setup using the T2OC bit otherwise no change will occur on the TM2 output pin when a compare match occurs. After the TM2 output pin changes state it can be reset to its initial level by changing the level of the T2ON bit from low to high.

In the PWM Mode, the T2IO1 and T2IO0 bits determine how the TM output pin changes state when a certain compare match condition occurs. The PWM output function is modified by changing these two bits. It is necessary to only change the values of the T2IO1 and T2IO0 bits only after the TM2 has been switched off. Unpredictable PWM outputs will occur if the T2IO1 and T2IO0 bits are changed when the TM is running.

- Bit 3 **T2OC:** TP2_0, TP2_1 Output control bit
Compare Match Output Mode
 0: Initial low
 1: Initial high
PWM Mode/ /Single Pulse Output Mode
 0: Active low
 1: Active high

This is the output control bit for the TM2 output pin. Its operation depends upon whether TM2 is being used in the Compare Match Output Mode or in the PWM Mode / Single Pulse Output Mode. It has no effect if the TM2 is in the Timer/Counter Mode. In the Compare Match Output Mode it determines the logic level of the TM2 output pin before a compare match occurs. In the PWM Mode it determines if the PWM signal is active high or active low.

- Bit 2 **T2POL:** TP2_0, TP2_1 Output polarity Control
 0: Non-invert
 1: Invert

This bit controls the polarity of the TP2_0 or TP2_1 output pin. When the bit is set high the TM2 output pin will be inverted and not inverted when the bit is zero. It has no effect if the TM2 is in the Timer/Counter Mode.

- Bit 1 **T2DPX:** TM2 PWM period/duty Control
 0: CCRP - period; CCRA - duty
 1: CCRP - duty; CCRA - period

This bit, determines which of the CCRA and CCRP registers are used for period and duty control of the PWM waveform.

- Bit 0 **T2CCLR:** Select TM2 Counter clear condition
 0: TM2 Comparator P match
 1: TM2 Comparator A match

This bit is used to select the method which clears the counter. Remember that the Compact TM2 contains two comparators, Comparator A and Comparator P, either of which can be selected to clear the internal counter. With the T2CCLR bit set high, the counter will be cleared when a compare match occurs from the Comparator A. When the bit is low, the counter will be cleared when a compare match occurs from the Comparator P or with a counter overflow. A counter overflow clearing method can only be implemented if the CCRP bits are all cleared to zero. The T2CCLR bit is not used in the PWM Mode.

TM2DL Register – 10-bit STM

Bit	7	6	5	4	3	2	1	0
Name	D7	D6	D5	D4	D3	D2	D1	D0
R/W	R	R	R	R	R	R	R	R
POR	0	0	0	0	0	0	0	0

Bit 7~0 **TM2DL:** TM2 Counter Low Byte Register bit 7~bit 0
TM2 10-bit Counter bit 7~bit 0

TM2DH Register – 10-bit STM

Bit	7	6	5	4	3	2	1	0
Name	—	—	—	—	—	—	D9	D8
R/W	—	—	—	—	—	—	R	R
POR	—	—	—	—	—	—	0	0

Bit 7~2 Unimplemented, read as "0"
Bit 1~0 **TM2DH:** TM2 Counter High Byte Register bit 1~bit 0
TM2 10-bit Counter bit 9~bit 8

TM2AL Register – 10-bit STM

Bit	7	6	5	4	3	2	1	0
Name	D7	D6	D5	D4	D3	D2	D1	D0
R/W	R/W	R/W	R/W	R/W	R/W	R/W	R/W	R/W
POR	0	0	0	0	0	0	0	0

Bit 7~0 **TM2AL:** TM2 CCRA Low Byte Register bit 7~bit 0
TM2 10-bit CCRA bit 7~bit 0

TM2AH Register – 10-bit STM

Bit	7	6	5	4	3	2	1	0
Name	—	—	—	—	—	—	D9	D8
R/W	—	—	—	—	—	—	R/W	R/W
POR	—	—	—	—	—	—	0	0

Bit 7~2 Unimplemented, read as "0"
Bit 1~0 **TM2AH:** TM2 CCRA High Byte Register bit 1~bit 0
TM2 10-bit CCRA bit 9~bit 8

Standard Type TM Operating Modes

The Standard Type TM can operate in one of five operating modes, Compare Match Output Mode, PWM Output Mode, Single Pulse Output Mode, Capture Input Mode or Timer/Counter Mode. The operating mode is selected using the T2M1 and T2M0 bits in the TM2C1 register.

Compare Output Mode

To select this mode, bits T2M1 and T2M0 in the TM2C1 register, should be set to 00 respectively. In this mode once the counter is enabled and running it can be cleared by three methods. These are a counter overflow, a compare match from Comparator A and a compare match from Comparator P. When the T2CCLR bit is low, there are two ways in which the counter can be cleared. One is when a compare match from Comparator P, the other is when the CCRP bits are all zero which allows the counter to overflow. Here both T2AF and T2PF interrupt request flags for Comparator A and Comparator P respectively, will both be generated.

If the T2CCLR bit in the TM2C1 register is high then the counter will be cleared when a compare match occurs from Comparator A. However, here only the T2AF interrupt request flag will be generated even if the value of the CCRP bits is less than that of the CCRA registers. Therefore when T2CCLR is high no T2PF interrupt request flag will be generated. In the Compare Match Output Mode, the CCRA can not be set to "0".

As the name of the mode suggests, after a comparison is made, the TM output pin, will change state. The TM output pin condition however only changes state when a T2AF interrupt request flag is generated after a compare match occurs from Comparator A. The T2PF interrupt request flag, generated from a compare match occurs from Comparator P, will have no effect on the TM output pin. The way in which the TM output pin changes state are determined by the condition of the T2IO1 and T2IO0 bits in the TM2C1 register. The TM output pin can be selected using the T2IO1 and T2IO0 bits to go high, to go low or to toggle from its present condition when a compare match occurs from Comparator A. The initial condition of the TM output pin, which is setup after the T2ON bit changes from low to high, is setup using the T2OC bit. Note that if the T2IO1 and T2IO0 bits are zero then no pin change will take place.

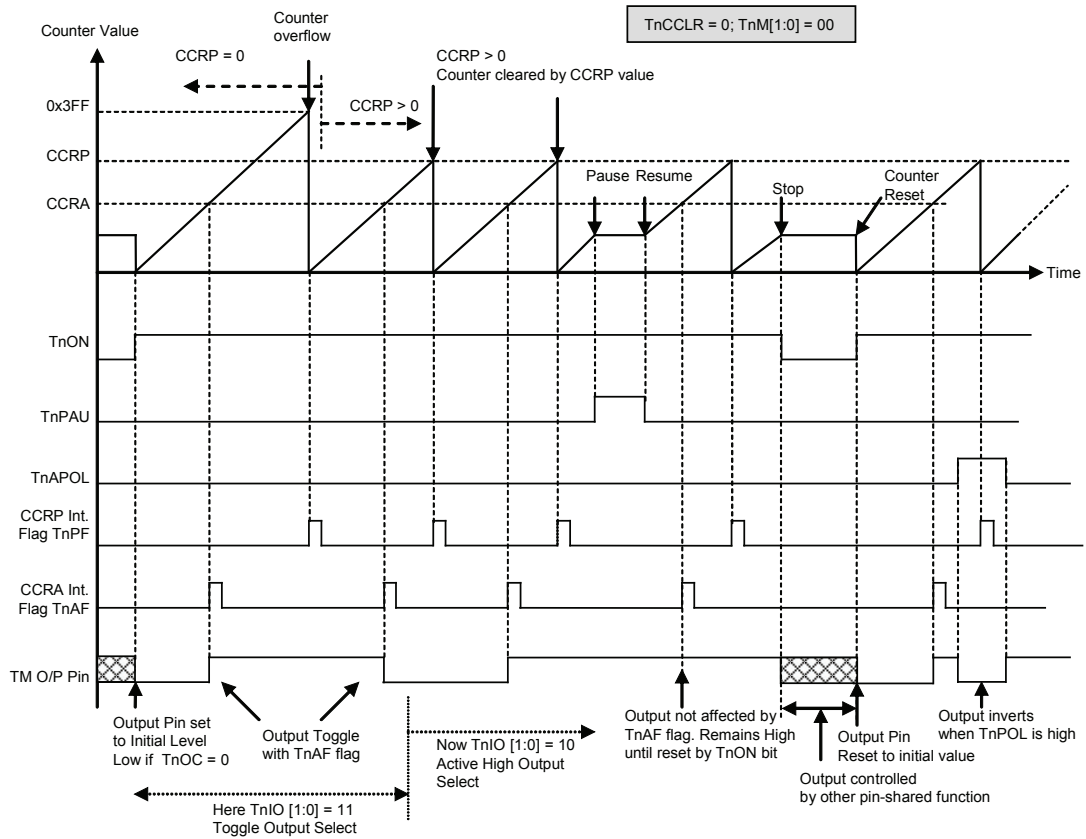

Compare Match Output Mode – TnCCLR=0

- Note: 1. With $TnCCLR = 0$ a Comparator P match will clear the counter
 2. The TM output pin controlled only by the TnAF flag
 3. The output pin reset to initial state by a TnON bit rising edge
 4. $n = 2$

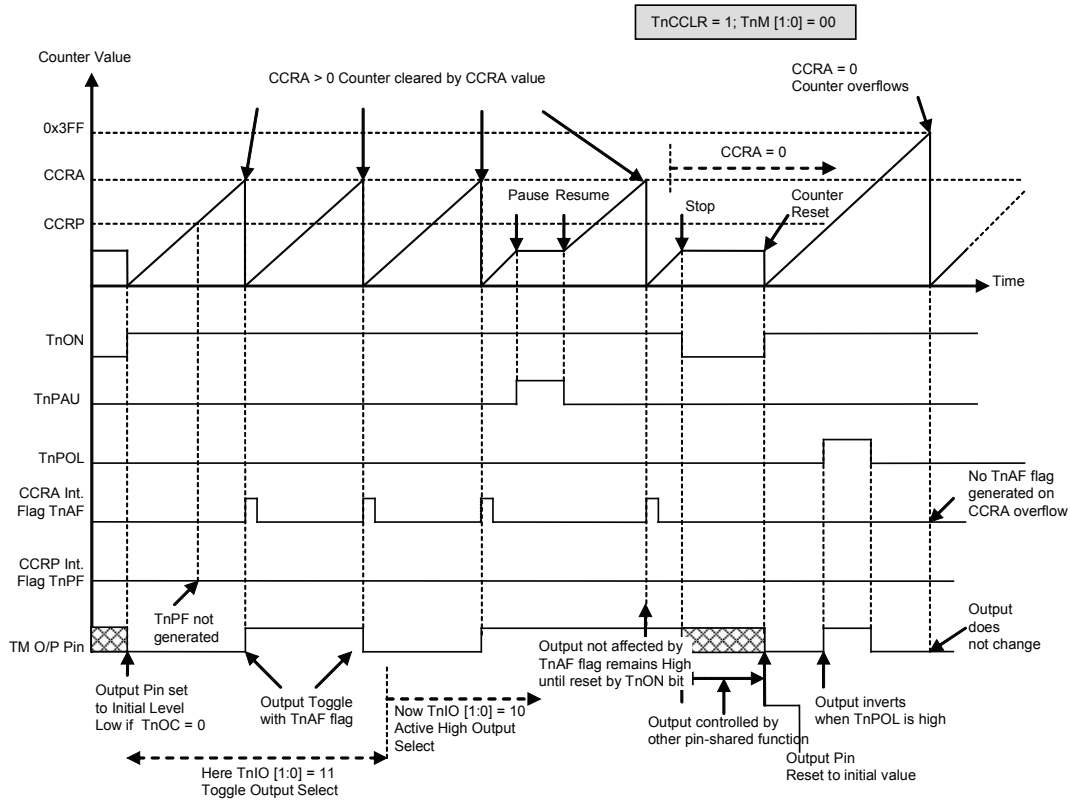

Compare Match Output Mode – TnCCLR=1

- Note:
1. With $TnCCLR = 1$ a Comparator A match will clear the counter
 2. The TM output pin controlled only by the TnAF flag
 3. The output pin reset to initial state by a TnON rising edge
 4. The TnPF flags is not generated when $TnCCLR = 1$
 5. $n = 2$

Timer/Counter Mode

To select this mode, bits T2M1 and T2M0 in the TM2C1 register should be set to 11 respectively. The Timer/Counter Mode operates in an identical way to the Compare Match Output Mode generating the same interrupt flags. The exception is that in the Timer/Counter Mode the TM output pin is not used. Therefore the above description and Timing Diagrams for the Compare Match Output Mode can be used to understand its function. As the TM output pin is not used in this mode, the pin can be used as a normal I/O pin or other pin-shared function.

PWM Output Mode

To select this mode, bits T2M1 and T2M0 in the TM2C1 register should be set to 10 respectively and also the T2IO1 and T2IO0 bits should be set to 10 respectively. The PWM function within the TM is useful for applications which require functions such as motor control, heating control, illumination control etc. By providing a signal of fixed frequency but of varying duty cycle on the TM output pin, a square wave AC waveform can be generated with varying equivalent DC RMS values.

As both the period and duty cycle of the PWM waveform can be controlled, the choice of generated waveform is extremely flexible. In the PWM mode, the T2CCLR bit has no effect as the PWM period. Both of the CCRA and CCRP registers are used to generate the PWM waveform, one register is used to clear the internal counter and thus control the PWM waveform frequency, while the other one is used to control the duty cycle. Which register is used to control either frequency or duty cycle is determined using the T2DPX bit in the TM2C1 register.

The PWM waveform frequency and duty cycle can therefore be controlled by the values in the CCRA and CCRP registers. An interrupt flag, one for each of the CCRA and CCRP, will be generated when a compare match occurs from either Comparator A or Comparator P. The T2OC bit in the TM2C1 register is used to select the required polarity of the PWM waveform while the two T2IO1 and T2IO0 bits are used to enable the PWM output or to force the TM output pin to a fixed high or low level. The T2POL bit is used to reverse the polarity of the PWM output waveform.

10-bit STM, PWM Mode, Edge-aligned Mode, T2DPX=0

CCRP	001	010	011	100	101	110	111	000
Period	128	256	384	512	640	768	896	1024
Duty	CCRA							

If $f_{SYS} = 4\text{MHz}$, TM clock source is f_{SYS} , CCRP = 2 and CCRA = 128,

The STM PWM output frequency = $f_{SYS} / (2 \times 256) = f_{SYS} / 512 = 7.8125\text{ kHz}$, duty = $128 / (2 \times 256) = 25\%$.

If the Duty value defined by the CCRA register is equal to or greater than the Period value, then the PWM output duty is 100%.

10-bit STM, PWM Mode, Edge-aligned Mode, T2DPX=1

CCRP	001	010	011	100	101	110	111	000
Period	CCRA							
Duty	128	256	384	512	640	768	896	1024

The PWM output period is determined by the CCRA register value together with the TM clock while the PWM duty cycle is defined by the CCRP register value.

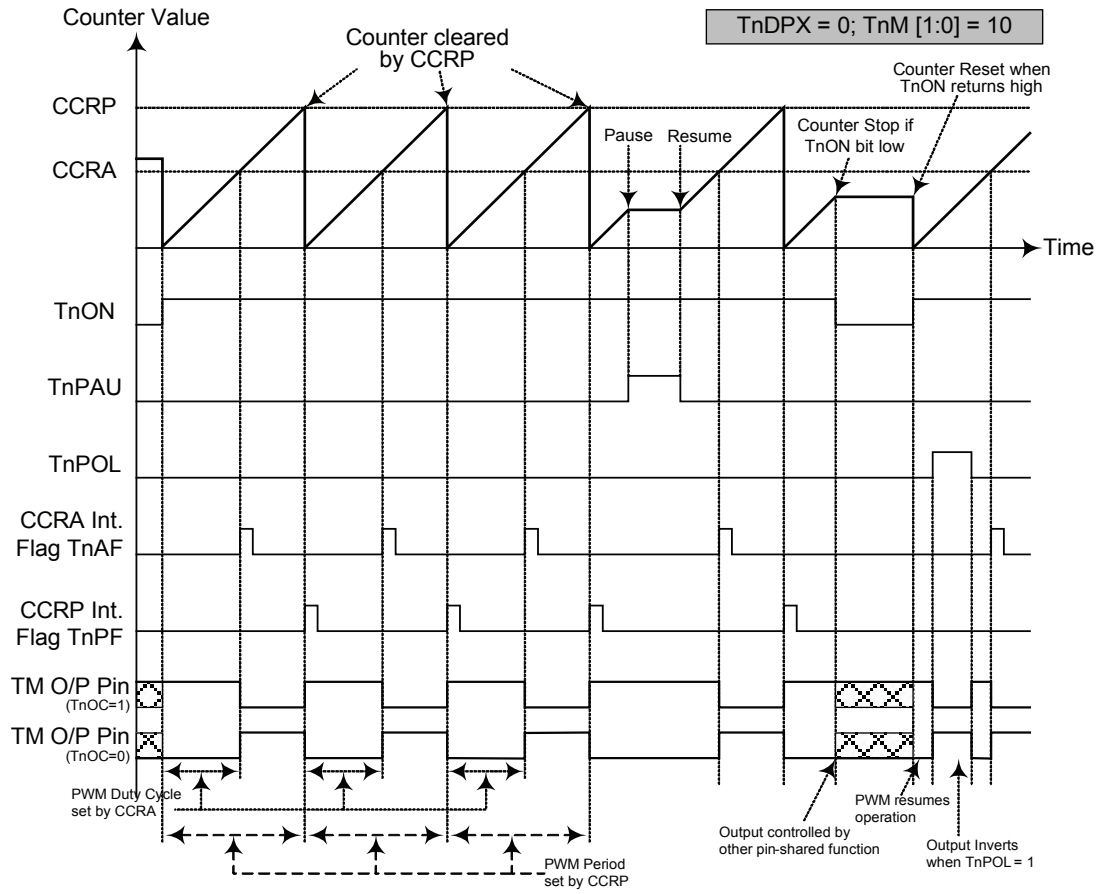

PWM Mode – TnDPX=0

Note: 1. Here TnDPX = 0 - Counter cleared by CCRP

2. A counter clear sets PWM Period
3. The internal PWM function continues running even when TnIO[1:0] = 00 or 01
4. The TnCCLR bit has no influence on PWM operation
5. n = 2

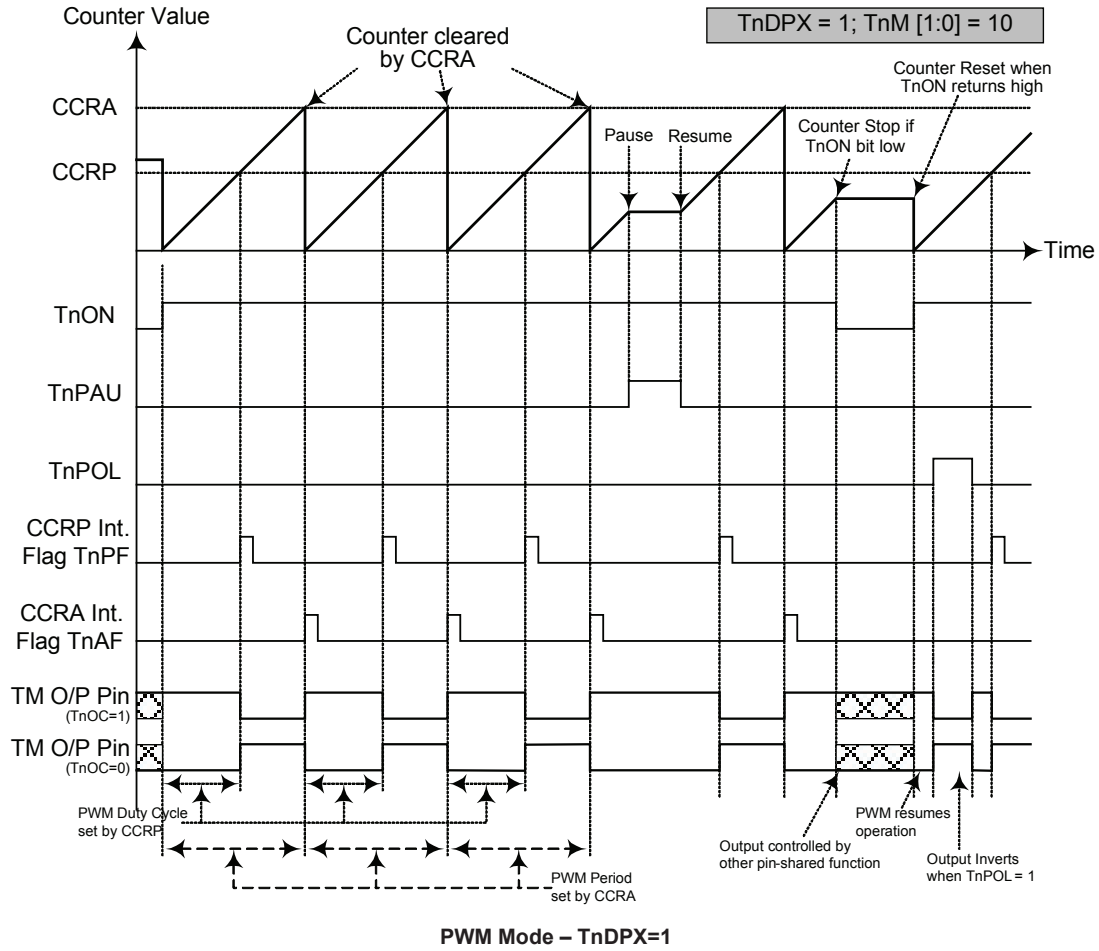

- Note: 1. Here TnDPX = 1 - Counter cleared by CCRA
2. A counter clear sets PWM Period
 3. The internal PWM function continues even when TnIO[1:0] = 00 or 01
 4. The TnCCLR bit has no influence on PWM operation
 5. n = 2

Single Pulse Mode

To select this mode, bits T2M1 and T2M0 in the TM2C1 register should be set to 10 respectively and also the T2IO1 and T2IO0 bits should be set to 11 respectively. The Single Pulse Output Mode, as the name suggests, will generate a single shot pulse on the TM output pin.

The trigger for the pulse output leading edge is a low to high transition of the T2ON bit, which can be implemented using the application program. However in the Single Pulse Mode, the T2ON bit can also be made to automatically change from low to high using the external TCK2 pin, which will in turn initiate the Single Pulse output. When the T2ON bit transitions to a high level, the counter will start running and the pulse leading edge will be generated. The T2ON bit should remain high when the pulse is in its active state. The generated pulse trailing edge will be generated when the T2ON bit is cleared to zero, which can be implemented using the application program or when a compare match occurs from Comparator A.

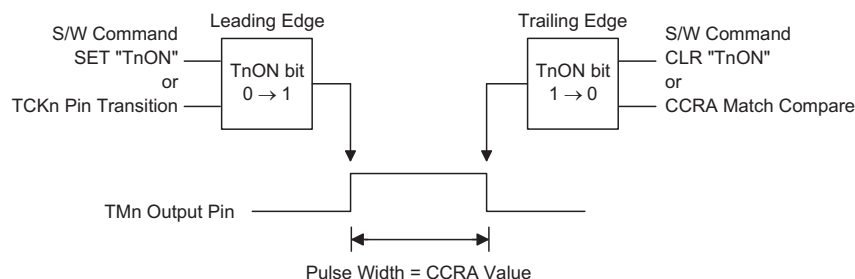

Single Pulse Generation (n=2)

However a compare match from Comparator A will also automatically clear the T2ON bit and thus generate the Single Pulse output trailing edge. In this way the CCRA value can be used to control the pulse width. A compare match from Comparator A will also generate a TM interrupt. The counter can only be reset back to zero when the T2ON bit changes from low to high when the counter restarts. In the Single Pulse Mode CCRP is not used. The T2CCLR and T2DPX bits are not used in this Mode.

Capture Input Mode

To select this mode bits T2M1 and T2M0 in the TM2C1 register should be set to 01 respectively. This mode enables external signals to capture and store the present value of the internal counter and can therefore be used for applications such as pulse width measurements. The external signal is supplied on the TP2_0 or TP2_1 pin, whose active edge can be either a rising edge, a falling edge or both rising and falling edges; the active edge transition type is selected using the T2IO1 and T2IO0 bits in the TM2C1 register. The counter is started when the T2ON bit changes from low to high which is initiated using the application program.

When the required edge transition appears on the TP2_0 or TP2_1 pin the present value in the counter will be latched into the CCRA registers and a TM interrupt generated. Irrespective of what events occur on the TP2_0 or TP2_1 pin the counter will continue to free run until the T2ON bit changes from high to low. When a CCRP compare match occurs the counter will reset back to zero; in this way the CCRP value can be used to control the maximum counter value. When a CCRP compare match occurs from Comparator P, a TM interrupt will also be generated. Counting the number of overflow interrupt signals from the CCRP can be a useful method in measuring long pulse widths. The T2IO1 and T2IO0 bits can select the active trigger edge on the TP2_0 or TP2_1 pin to be a rising edge, falling edge or both edge types. If the TnIO1 and T2IO0 bits are both set high, then no capture operation will take place irrespective of what happens on the TP2_0 or TP2_1 pin, however it must be noted that the counter will continue to run.

As the TP2_0 or TP2_1 pin is pin shared with other functions, care must be taken if the TM is in the Input Capture Mode. This is because if the pin is setup as an output, then any transitions on this pin may cause an input capture operation to be executed. The T2CCLR and T2DPX bits are not used in this Mode.

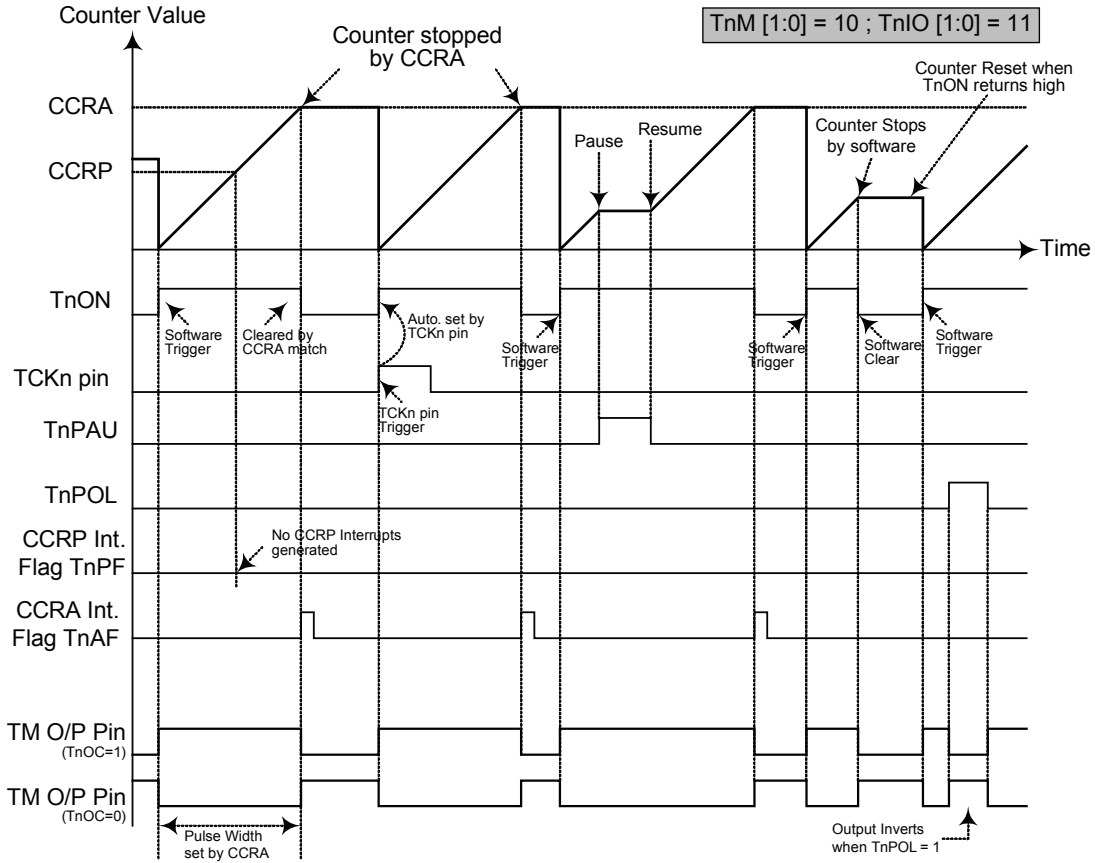

TnM [1:0] = 10 ; TnIO [1:0] = 11

Single Pulse Mode

- Note: 1. Counter stopped by CCRA match
 2. CCRP is not used
 3. The pulse is triggered by the TCKn pin or setting the TnON bit high
 4. A TCKn pin active edge will automatically set the TnON bit high
 5. In the Single Pulse Mode, TnIO [1:0] must be set to "11" and can not be changed.
 6. n = 2

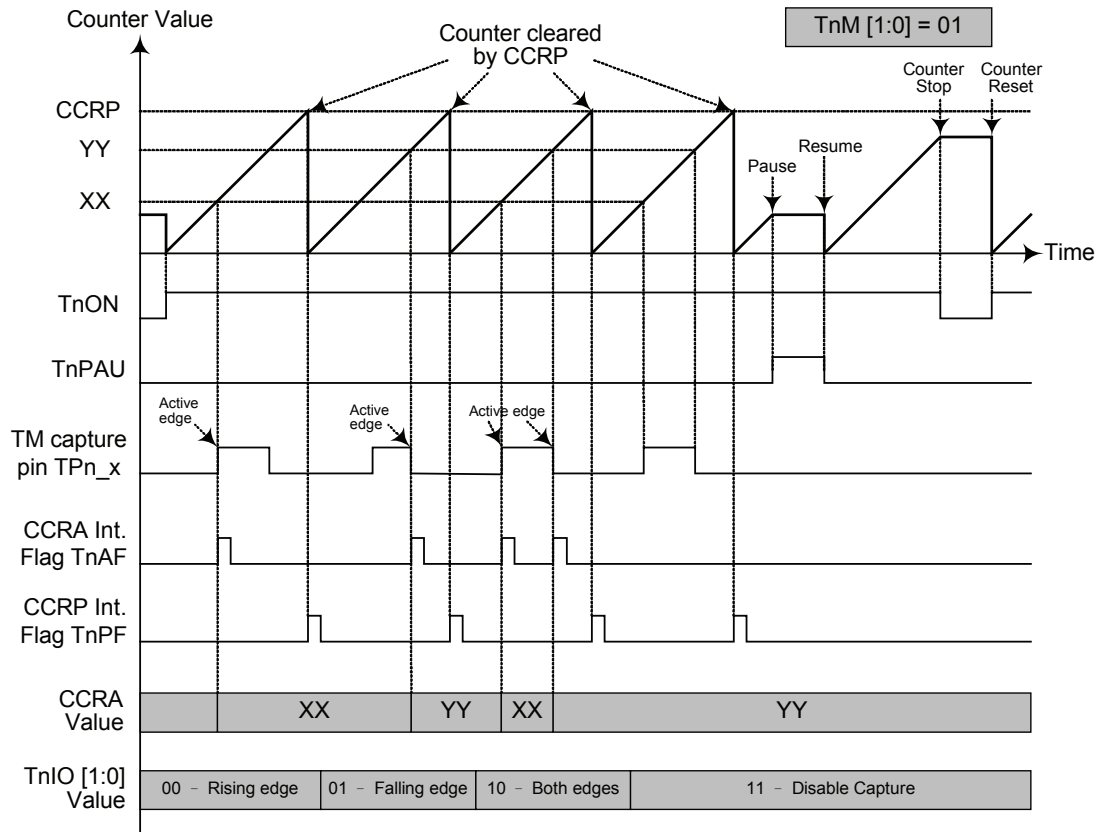

Capture Input Mode

- Note: 1. TnM[1:0] = 01 and active edge set by the TnIO[1:0] bits
2. A TM Capture input pin active edge transfers the counter value to CCRA
 3. The TnCCLR bit is not used
 4. No output function - TnOC and TnPOL bits are not used
 5. CCRP determines the counter value and the counter has a maximum count value when CCRP is equal to zero.
 6. n = 2

Capture Timer Module – CAPTM

The Capture Timer Module is a timing unit specifically used for Motor Control purposes. The CAPTM is controlled by a program selectable clock source and by three interrupt sources from the motor positioning hall sensors.

Capture Timer Overview

At the core of the Capture Timer is a 16-bit count-up counter which is driven by a user selectable internal clock source which is some multiple of the system clock or by the PWM. There is also an internal comparator which compares the value of this 16-bit counter with a pre-programmed 16-bit value stored in two registers. There are two basic modes of operation, a Compare Mode and a Capture Mode, each of which can be used to reset the internal counter. When a compare match situation is reached a signal will be generated to reset the internal counter. The counter can also be cleared when a capture trigger is generated by the three external sources, H1, H2 and H3.

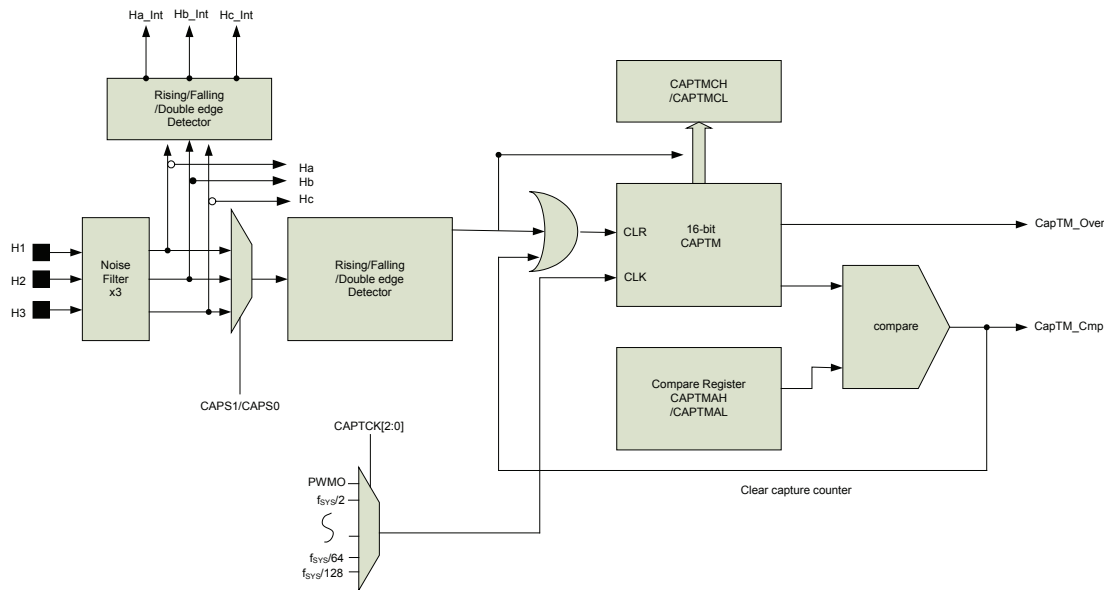

Capture Timer Block Diagram

Capture Timer Register Description

Overall operation of the Capture Timer is controlled using eight registers. A read only register pair exists to store the internal counter 16-bit value, while a read/write register pair exists to store the internal 16-bit compare value. An additional read only register pair is used to store the capture value. The remaining two registers are control registers which setup the different operating and control modes.

Name	Bit 7	Bit 6	Bit 5	Bit 4	Bit 3	Bit 2	Bit 1	Bit 0
CAPTC0	CAPTPAU	CAPTCK2	CAPTCK1	CAPTCK0	CAPTON	—	CAPS1	CAPS0
CAPTC1	CAPEG1	CAPEG0	CAPEN	CAPNFT	CAPNFS	CAPFIL	CAPCLR	CAMCLR
CAPTMDL	D7	D6	D5	D4	D3	D2	D1	D0
CAPTM DH	D15	D14	D13	D12	D11	D10	D9	D8
CAPTMAL	D7	D6	D5	D4	D3	D2	D1	D0
CAPTM AH	D15	D14	D13	D12	D11	D10	D9	D8
CAPTMCL	D7	D6	D5	D4	D3	D2	D1	D0
CAPTMCH	D15	D14	D13	D12	D11	D10	D9	D8

Capture Timer Register List

CAPTC0 Register

Bit	7	6	5	4	3	2	1	0
Name	CAPTPAU	CAPTCK2	CAPTCK1	CAPTCK0	CAPTON	—	CAPS1	CAPS0
R/W	R/W	R/W	R/W	R/W	R/W	—	R/W	R/W
POR	0	0	0	0	0	—	0	0

- Bit 7 CAPTPAU:** CAPTM Counter Pause Control
 0: Run
 1: Pause
 The counter can be paused by setting this bit high. Clearing the bit to zero restores normal counter operation. When in a Pause condition the CAPTM will remain power up and continue to consume power. The counter will retain its residual value when this bit changes from low to high and resume counting from this value when the bit changes to a low value again.
- Bit 6~4 CAPTCK2~CAPTCK0:** Select CAPTM Counter clock
 000: PWMO
 001: $f_H/2$
 010: $f_H/4$
 011: $f_H/8$
 100: $f_H/16$
 101: $f_H/32$
 110: $f_H/64$
 111: $f_H/128$
 These three bits are used to select the clock source for the CAPTM. The clock source f_H is the high speed system oscillator.
- Bit 3 CAPTON:** CAPTM Counter On/Off Control
 0: Off
 1: On
 This bit controls the overall on/off function of the CAPTM. Setting the bit high enables the counter to run, clearing the bit disables the CAPTM. Clearing this bit to zero will stop the counter from counting and turn off the CAPTM which will reduce its power consumption. When the bit changes state from low to high the internal counter value will be reset to zero, however when the bit changes from high to low, the internal counter will retain its residual value.
- Bit 2** Unimplemented, read as "0"
- Bit 1~0 CAPS1~CAPS0:** capture source select
 00: H1
 01: H2
 10: H3
 11: CTIN

CAPTC1 Register

Bit	7	6	5	4	3	2	1	0
Name	CAPEG1	CAPEG0	CAPEN	CAPNFT	CAPNFS	CAPFIL	CAPCLR	CAMCLR
R/W	R/W	R/W	R/W	R/W	R/W	R/W	R/W	R/W
POR	0	0	0	0	0	0	0	0

- Bit 7~6 **CAPEG1~CAPEG0:** Defines CAPTM capture active edge
00: Disabled CAPTM capture
01: Rising edge capture
10: Falling edge capture
11: Dual edge capture
- Bit 5 **CAPEN:** CAPTM Capture input control
0: Disable
1: Enable
This bit enables/disables the CAPTM capture input source.
- Bit 4 **CAPNFT:** Defines CAPTM Noise Filter sample times
0: Twice
1: 4 times
The CAPTM Noise Filter circuit requires sampling twice or 4 times continuously, when they are all the same, the signal will be acknowledged. The sample time is decided by CAPNFS.
- Bit 3 **CAPNFS:** CAPTM Noise Filter clock source Select
0: t_{sys}
1: $4t_{sys}$
The clock source for Capture Timer Module Counter is provided by f_{sys} or $f_{sys}/4$.
- Bit 2 **CAPFIL:** CAPTM capture input filter Control
0: Disable
1: Enable
This bit enables/disables the CAPTM capture input filter.
- Bit 1 **CAPCLR:** CAPTM Counter capture auto-reset Control
0: Disable
1: Enable
This bit enables/disables the automatic reset of the counter when the value in CAPTMDL and CAPTMDH have been transferred into the capture registers CAPTMCL and CAPTMCH.
- Bit 0 **CAMCLR:** CAPTM Counter compare match auto-reset Control
0: Disable
1: Enable
This bit enables/disables the automatic reset of the counter when a compare match has occurred.

CAPTMDL Register

Bit	7	6	5	4	3	2	1	0
Name	D7	D6	D5	D4	D3	D2	D1	D0
R/W	R/W	R/W	R/W	R/W	R/W	R/W	R/W	R/W
POR	0	0	0	0	0	0	0	0

- Bit 7~0 **CAPTMDL:** CAPTM Counter Low Byte Register bit 7~bit 0
CAPTM 16-bit Counter bit 7 ~ bit 0

CAPTMDH Register

Bit	7	6	5	4	3	2	1	0
Name	D15	D14	D13	D12	D11	D10	D9	D8
R/W	R/W	R/W	R/W	R/W	R/W	R/W	R/W	R/W
POR	0	0	0	0	0	0	0	0

Bit 7~0 **CAPTMDH:** CAPTM Counter High Byte Register bit 7~bit 0
CAPTM 16-bit Counter bit 15 ~ bit 8.

CAPTML Register

Bit	7	6	5	4	3	2	1	0
Name	D7	D6	D5	D4	D3	D2	D1	D0
R/W	R/W	R/W	R/W	R/W	R/W	R/W	R/W	R/W
POR	0	0	0	0	0	0	0	0

Bit 7~0 **CAPTML:** CAPTM Compare Low Byte Register bit 7~bit 0
CAPTM 16-bit Compare Register bit 7~bit 0.

CAPTMAH Register

Bit	7	6	5	4	3	2	1	0
Name	D15	D14	D13	D12	D11	D10	D9	D8
R/W	R/W	R/W	R/W	R/W	R/W	R/W	R/W	R/W
POR	0	0	0	0	0	0	0	0

Bit 7~0 **CAPTMAH:** CAPTM Compare High Byte Register bit 7~bit 0
CAPTM 16-bit Compare Register bit 15~bit 8.

CAPTML Register

Bit	7	6	5	4	3	2	1	0
Name	D7	D6	D5	D4	D3	D2	D1	D0
R/W	R	R	R	R	R	R	R	R
POR	x	x	x	x	x	x	x	x

"x"unknown

Bit 7~0 **CAPTML:** CAPTM Capture Low Byte Register bit 7~bit 0
CAPTM 16-bit Capture Register bit 7~bit 0

CAPTCH Register

Bit	7	6	5	4	3	2	1	0
Name	D15	D14	D13	D12	D11	D10	D9	D8
R/W	R	R	R	R	R	R	R	R
POR	x	x	x	x	x	x	x	x

"x"unknown

Bit 7~0 **CAPTCH:** CAPTM Capture High Byte Register bit 7~bit 0
CAPTM 16-bit Capture Register bit 15~bit 8.

Capture Timer Operation

The Capture Timer is used to detect and measure input signal pulse widths and a periods. It can be used in both a Capture or Compare Mode. The timer inputs are the four capture inputs H1, H2 and H3. Each of these capture inputs has its own edge detector selection, to choose between high, low or both edge trigger types.

The CAPTON bit is used to control the overall Capture Timer enable/disable function. Disabling the Capture Module when not used will reduce the device power consumption. Additionally the capture input control is enabled/disabled using the CAPEN control bit. The trigger edge options are setup using the CAPEG1 and CAPEG0 bits, to select either positive edge, negative edge or both edges.

The timer also includes a noise Filter which is used to filter out unwanted glitches or pulses on the H1, H2, H3 and NFIN input pins. This function is enabled using the CAPFIL bit. If the noise filter is enabled, the capture input signals must be sampled either 2 or 4 times, in order to recognize an edge as a valid capture event. The sampling 2 or 4 time units are based on either t_{SYS} or $4 \times t_{SYS}$ determined using the CAPNFS bit.

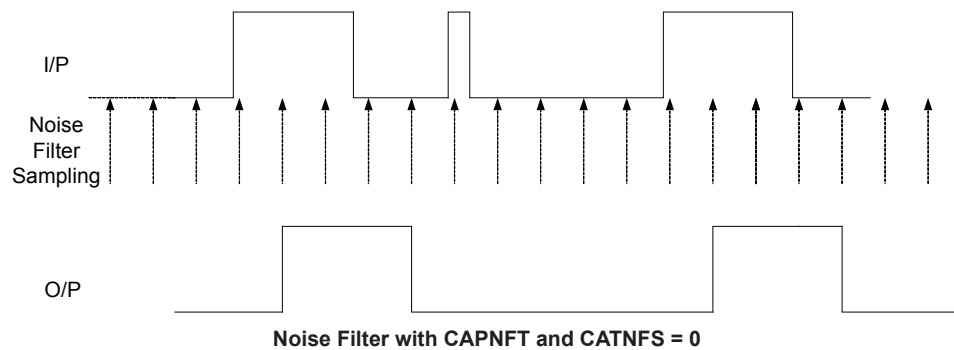

Capture Mode Operation

The capture timer module contains 2 capture registers, CAPTMCL and CAPTMCH, which are used to store the present value in the counter. When the Capture Module is enabled, then each time an external pin receives a valid trigger signal, the content of the free running 16-bit counter, which is contained in the CAPTMDL and CAPTMDH registers, will be captured into the capture registers, CAPTMCL and CAPTMCH. When this occurs, the CAPOF interrupt flag bit in the interrupt control register will be set. If this interrupt is enabled by setting the interrupt enable bit, CAPOE, high, an interrupt will be generated. If the CAPCLR bit is set high, then the 16-bit counter will be automatically reset after a capture event occurs.

Compare Mode Operation

When the timer is used in the compare mode, the CAPTMAL and CAPTMAH registers are used to store the 16-bit compare value. When the free running value of the count-up 16-bit counter reaches a value equal to the programmed values in these compare registers, the CAPCF interrupt flag will be set which will generate an interrupt if its related interrupt enable bit is set. If the CAMCLR bit is set high, then the counter will be reset to zero automatically when a compare match condition occurs. The rotor speed or a stalled motor condition can be detected by setting the compare registers to compare the captured signal edge transition time. If a rotor stall condition occurs, then a compare interrupt will be generated, after which the PWM motor drive circuit can be shut down to prevent a motor burn out situation.

Noise Filter

The external NFIN pin is connected to an internal filter to reduce the possibility of unwanted event counting events or inaccurate pulse width measurements due to adverse noise or spikes on the NFIN input signal and then output to STM capture circuit. In order to ensure that the motor control circuit works normally.

The noise filter circuit is an I/O filtering surge compare which can filter micro-second grade sharp-noise.

Antinoise pulse width maximum: $(NF_VIH[4:0]-NF_VIL[4:0]) \times 5\mu s$, $(NF_VIH[4:0]-NF_VIL[4:0]) > 1$

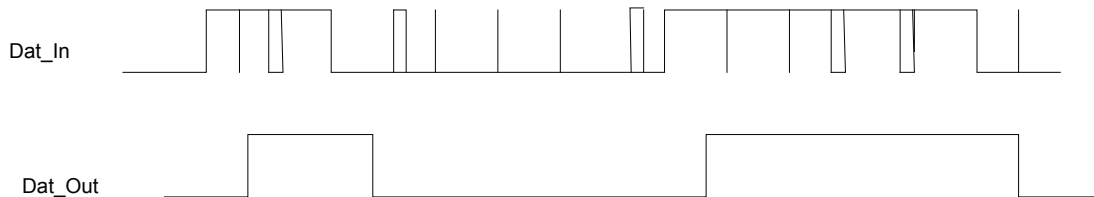
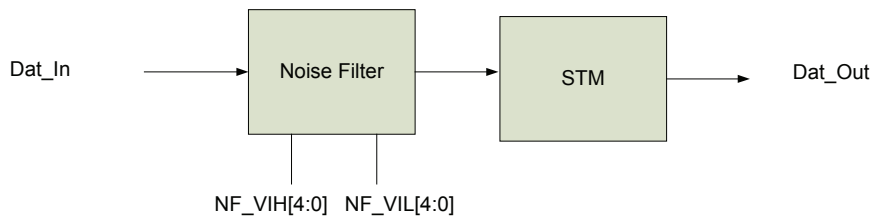

Noise Filter Registers Description

NF_VIH Register

Bit	7	6	5	4	3	2	1	0
Name	NF_BYPS	CINS	—	D4	D3	D2	D1	D0
R/W	R/W	R/W	—	R/W	R/W	R/W	R/W	R/W
POR	0	0	—	1	1	0	0	1

Bit 7 **NF_BYPS:** Bypass Noise Filter Enable

0: Disable
 1: Enable, Dat_Out=Dat_In

Bit 6 **CINS:** STM capture source selection

0: No select Noise Filter Dat_Out(remains the original STM path)
 1: Select Noise Filter Dat_Out

Bit 5 Unimplemented, read as "0"

Bit 4~0 NF_VIH register Bit 4~Bit 0

NF_VIL Register

Bit	7	6	5	4	3	2	1	0
Name	NFIS1	NFIS0	—	D4	D3	D2	D1	D0
R/W	R/W	R/W	—	R/W	R/W	R/W	R/W	R/W
POR	0	0	—	0	1	0	1	0

Bit 7~6 **NFIS1~NFIS0**: NFIN Interrupt edge control

- 00: Disable
- 01: Rising edge trigger
- 10: Falling edge trigger
- 11: Dual edge trigger

Bit 5 Unimplement, read as "0"

Bit 4~0 NF_VIL register Bit 4~Bit0

Comparators

Four independent analog comparators are contained within these devices. These functions offer flexibility via their register controlled features such as power-down, polarity select, hysteresis etc. In sharing their pins with normal I/O pins the comparators do not waste precious I/O pins if there functions are otherwise unused.

Comparators Block Diagram

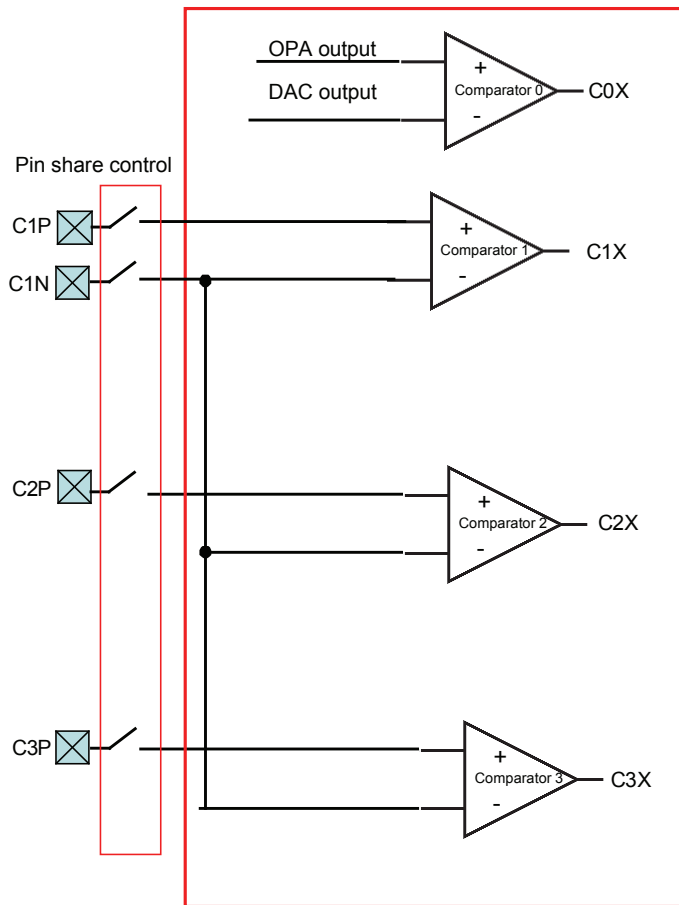

Comparator Operation

The device contains four comparator functions which are used to compare two analog voltages and provide an output based on their difference. Additional comparator functions include, output polarity, hysteresis functions and power down control. Any pull-high resistors connected to the shared comparator input pins will be automatically disconnected when the comparator pin-share is enabled. As the comparator inputs approach their switching level, some spurious output signals may be generated on the comparator output due to the slow rising or falling nature of the input signals.

This can be minimised by selecting the hysteresis function will apply a small amount of positive feedback to the comparator. Ideally the comparator should switch at the point where the positive and negative inputs signals are at the same voltage level, however, unavoidable input offsets introduce some uncertainties here. The hysteresis function, if enabled, also increases the switching offset value.

CPC Register

Bit	7	6	5	4	3	2	1	0
Name	C3HYEN	C2HYEN	C1HYEN	C0HYEN	C3EN	C2EN	C1EN	C0EN
R/W	R/W	R/W	R/W	R/W	R/W	R/W	R/W	R/W
POR	1	1	1	1	0	0	0	0

bit 7 **C3HYEN:** Comparator 3 Hysteresis Control

0: Off
 1: On

This is the hysteresis control bit and if set high will apply a limited amount of hysteresis to the comparator, as specified in the Comparator Electrical Characteristics table. The positive feedback induced by hysteresis reduces the effect of spurious switching near the comparator threshold.

bit 6 **C2HYEN:** Comparator 2 Hysteresis Control

0: Off
 1: On

This is the hysteresis control bit and if set high will apply a limited amount of hysteresis to the comparator, as specified in the Comparator Electrical Characteristics table. The positive feedback induced by hysteresis reduces the effect of spurious switching near the comparator threshold.

bit 5 **C1HYEN:** Comparator 1 Hysteresis Control

0: Off
 1: On

This is the hysteresis control bit and if set high will apply a limited amount of hysteresis to the comparator, as specified in the Comparator Electrical Characteristics table. The positive feedback induced by hysteresis reduces the effect of spurious switching near the comparator threshold.

bit 4 **C0HYEN:** Comparator 0 Hysteresis Control

0: Off
 1: On

This is the hysteresis control bit and if set high will apply a limited amount of hysteresis to the comparator, as specified in the Comparator Electrical Characteristics table. The positive feedback induced by hysteresis reduces the effect of spurious switching near the comparator threshold.

bit 3 **C3EN:** Comparator 3 On/Off control

0: Off
 1: On

This is the Comparator on/off control bit. If the bit is zero the comparator will be switched off and no power consumed even if analog voltages are applied to its inputs. For power sensitive applications this bit should be cleared to zero if the comparator is not used or before the device enters the Power-down mode.

- bit 2 **C2EN:** Comparator 2 On/Off control
 0: Off
 1: On
 This is the Comparator on/off control bit. If the bit is zero the comparator will be switched off and no power consumed even if analog voltages are applied to its inputs. For power sensitive applications this bit should be cleared to zero if the comparator is not used or before the device enters the Power-down mode.
- bit 1 **C1EN:** Comparator 1 On/Off control
 0: Off
 1: On
 This is the Comparator on/off control bit. If the bit is zero the comparator will be switched off and no power consumed even if analog voltages are applied to its inputs. For power sensitive applications this bit should be cleared to zero if the comparator is not used or before the device enters the Power-down mode.
- bit 0 **C0EN:** Comparator 0 On/Off control
 0: Off
 1: On
 This is the Comparator on/off control bit. If the bit is zero the comparator will be switched off and no power consumed even if analog voltages are applied to its inputs. For power sensitive applications this bit should be cleared to zero if the comparator is not used or before the device enters the Power-down mode.

Analog to Digital Converter

The need to interface to real world analog signals is a common requirement for many electronic systems. However, to properly process these signals by a microcontroller, they must first be converted into digital signals by A/D converters. By integrating the A/D conversion electronic circuitry into the microcontroller, the need for external components is reduced significantly with the corresponding follow-on benefits of lower costs and reduced component space requirements. This device also includes some special A/D features for specific use in motor control applications.

A/D Overview

This device contains a 6-channel analog to digital converter, 6-channel can be directly interface to external analog signals, such as that from sensors or other control signals and convert these signals directly into either a 10-bit digital value. An additional channel is connected to the external current sense input pin, AP, via an internal operational amplifier for signal amplification, before being transferred to the A/D converter input. A set of what are known as high and low boundary registers, allow the A/D converter digital output value to be compared with upper and lower limit values and a corresponding interrupt to be generated. An additional delay function allows a delay to be inserted into the PWM triggered A/D conversion start process to reduce the possibility of erroneous analog value sampling when the output power transistors are switching large motor currents.

Input Channels	A/D Channel Select Bits	Input Pins
6+1	ACS2~ACS0	AN0~AN5, AP

The accompanying block diagram shows the overall internal structure of the A/D converter, together with its associated registers.

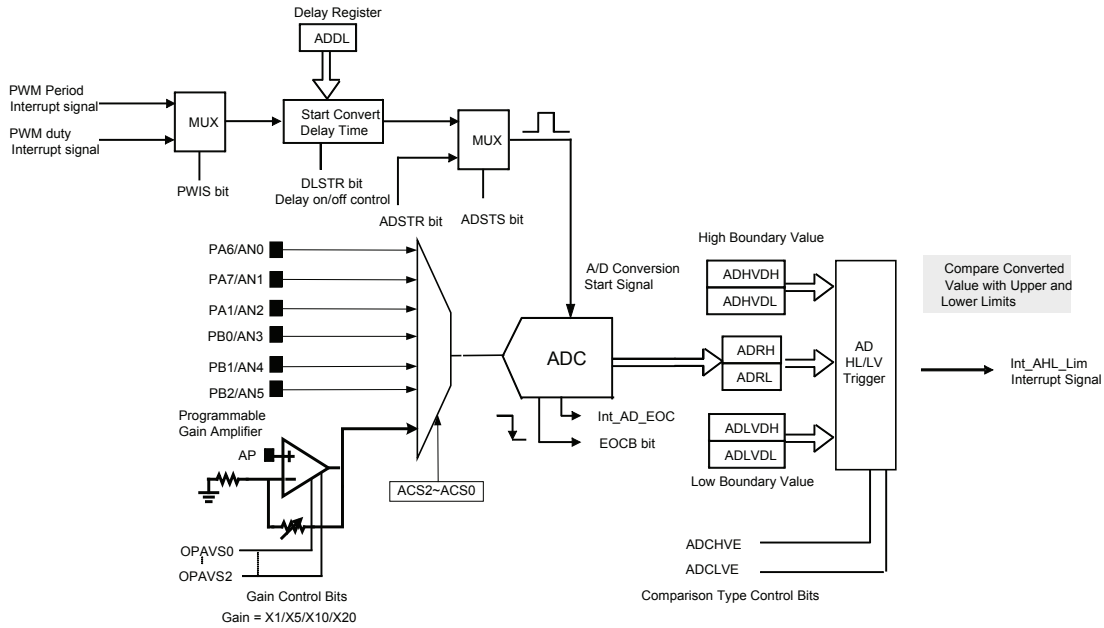

A/D Converter Structure

A/D Converter Register Description

Overall operation of the A/D converter is controlled using several registers. A read only register pair ADRL/ADRH exists to store the ADC data 10-bit value. The ADLVDL/ADLVDH and ADHVDL/ADHVDH registers are used to store the boundary limit values of the ADC interrupt trigger while the ADDL register is used to setup the start conversion delay time. The remaining registers are control registers which setup the operating and control function of the A/D converter.

Register Name	Bit							
	7	6	5	4	3	2	1	0
ADRL	D7	D6	D5	D4	D3	D2	D1	D0
ADRH	—	—	—	—	—	—	D9	D8
ADCR0	ADSTR	EOCB	ADOFF	—	—	ACS2	ACS1	ACS0
ADCR1	ADSTS	DLSTR	PWIS	ADCHVE	ADCLVE	ADCK2	ADCK1	ADCK0
ADCR2	—	—	—	—	—	—	PWDIS1	PWDIS0
ADDL	D7	D6	D5	D4	D3	D2	D1	D0
ADLVDL	D7	D6	D5	D4	D3	D2	D1	D0
ADLVDH	—	—	—	—	—	—	D9	D8
ADHVDL	D7	D6	D5	D4	D3	D2	D1	D0
ADHVDH	—	—	—	—	—	—	D9	D8

A/D Converter Register List

A/D Converter Data Registers – ADRL, ADRH

As this device contains an internal 10-bit A/D converter, it requires two data registers to store the converted value. These are a high byte register, known as ADRH, and a low byte register, known as ADRL. After the conversion process takes place, these registers can be directly read by the microcontroller to obtain the digitised conversion value.

ADRL Register

Bit	7	6	5	4	3	2	1	0
Name	D7	D6	D5	D4	D3	D2	D1	D0
R/W	R	R	R	R	R	R	R	R
POR	x	x	x	x	x	x	x	x

"x"unknown

Bit 7~0 A/D Low Byte Register Bit 7~Bit 0

ADRH Register

Bit	7	6	5	4	3	2	1	0
Name	—	—	—	—	—	—	D9	D8
R/W	—	—	—	—	—	—	R	R
POR	—	—	—	—	—	—	x	x

"x"unknown

Bit 7~2 Unimplemented, read as "0"

Bit 1~0 A/D High Byte Register Bit 1~Bit 0

A/D Converter Control Registers – ADCR0, ADCR1, ADCR2, ADDL

To control the function and operation of the A/D converter, four control registers known as ADCR0, ADCR1 and ADCR2 are provided. These 8-bit registers define functions such as the selection of which analog channel is connected to the internal A/D converter, the digitised data format, the A/D clock source as well as controlling the start function and monitoring the A/D converter end of conversion status. The ACS2~ACS0 bits in the ADCR0 register define the ADC input channel number. As the device contains only one actual analog to digital converter hardware circuit, each of the individual 6 analog inputs must be routed to the converter. It is the function of the ACS2~ACS0 bits to determine which analog channel input pins or AP pin is actually connected to the internal A/D converter.

The ADDL register exists to store the ADC delay start time.

ADCR0 Register

Bit	7	6	5	4	3	2	1	0
Name	ADSTR	EOCB	ADOFF	—	—	ACS2	ACS1	ACS0
R/W	R/W	R	R/W	—	—	R/W	R/W	R/W
POR	0	1	1	—	—	0	0	0

Bit 7 **ADSTR:** Start the A/D conversion

0→1→0 : start

0→1: reset the A/D converter and set EOCB to "1"

This bit is used to initiate an A/D conversion process. The bit is normally low but if set high and then cleared low again, the A/D converter will initiate a conversion process. When the bit is set high the A/D converter will be reset.

Bit 6 **EOCB:** End of A/D conversion flag

0: A/D conversion ended

1: A/D conversion in progress

This read only flag is used to indicate when an A/D conversion process has completed. When the conversion process is running the bit will be high.

- Bit 5 **ADOFF** : ADC module power on/off control bit
 0: ADC module power on
 1: ADC module power off
- This bit controls the power to the A/D internal function. This bit should be cleared to zero to enable the A/D converter. If the bit is set high then the A/D converter will be switched off reducing the device power consumption. As the A/D converter will consume a limited amount of power, even when not executing a conversion, this may be an important consideration in power sensitive battery powered applications.
- Note: 1. it is recommended to set ADOFF=1 before entering IDLE/SLEEP Mode for saving power.
 2. ADOFF=1 will power down the ADC module.
- Bit 4~3 Unimplemented, read as "0"
- Bit 2 ~ 0 **ACS2 ~ ACS0**: Select A/D channel
 000: AN0
 001: AN1
 010: AN2
 011: AN3
 100: AN4
 101: AN5
 110: OPA output
 111: Undefined
- These are the A/D channel select control bits. As there is only one internal hardware A/D converter each of the six A/D inputs must be routed to the internal converter using these bits.

ADCR1 Register

Bit	7	6	5	4	3	2	1	0
Name	ADSTS	DLSTR	PWIS	ADCHVE	ADCLVE	ADCK2	ADCK1	ADCK0
R/W	R/W	R/W	R/W	R/W	R/W	R/W	R/W	R/W
POR	0	0	0	0	0	0	0	0

- Bit 7 **ADSTS**: Select ADC trigger circuit
 0: Select ADSTR trigger circuit
 1: Select DELAY trigger circuit
- Bit 6 **DLSTR**: Delay start function control
 0: Disable but need to set ADDL to "0"
 1: Enable but need to set ADDL to non zero value
- Bit 5 **PWIS**: Select PWM Module interrupt source
 0: Select PWM period interrupt
 1: Select PWM duty interrupt
- Bit 4~3 **ADCHVE, ADCLVE**: Select ADC interrupt trigger source
 00: ADLVD[9:0] < ADR[9:0] < ADHVD[9:0]
 01: ADR[9:0] <= ADLVD[9:0]
 10: ADR[9:0] >= ADHVD[9:0]
 11: ADR[9:0] <= ADLVD[9:0] or ADR[9:0] >= ADHVD[9:0]
- Bit 2 ~ 0 **ADCK2 ~ ADCK0**: Select ADC clock source
 000: f_{sys}
 001: f_{sys}/2
 010: f_{sys}/4
 011: f_{sys}/8
 100: f_{sys}/16
 101: f_{sys}/32
 110: f_{sys}/64
 111: Undefined
- These three bits are used to select the clock source for the A/D converter.

ADCR2 Register

Bit	7	6	5	4	3	2	1	0
Name	—	—	—	—	—	—	PWDIS1	PWDIS0
R/W	—	—	—	—	—	—	R/W	R/W
POR	—	—	—	—	—	—	0	0

Bit 7~2 Unimplemented, read as "0"

Bit 1~0 **PWDIS1~PWDIS0:** PWIS=1, select PWMn duty cycle interrupt trigger source
 00: PWM0
 01: PWM1
 10: PWM2
 11: Reserved(select PWM2 duty cycle interrupt trigger source)

ADDL Register

Bit	7	6	5	4	3	2	1	0
Name	D7	D6	D5	D4	D3	D2	D1	D0
R/W	R/W	R/W	R/W	R/W	R/W	R/W	R/W	R/W
POR	0	0	0	0	0	0	0	0

Bit 7~0 ADC Delay-Time register Bit 7~Bit 0
 Delay-Time Value (count by system clock)

A/D Converter Boundary Registers – ADLVDL, ADLVDH, ADHVDL, ADHVDH

The device contains what are known as boundary registers to store fixed values for comparison with the A/D converter converted value stored in ADRL and ADRH. There are two pairs of registers, a high boundary pair, known as ADHVDL and ADHVDH and a low boundary pair known as ADLVDL and ADLVDH.

ADLVDL Register

Bit	7	6	5	4	3	2	1	0
Name	D7	D6	D5	D4	D3	D2	D1	D0
R/W	R/W	R/W	R/W	R/W	R/W	R/W	R/W	R/W
POR	0	0	0	0	0	0	0	0

Bit 7~0 ADC Low Boundary Low Byte Register Bit 7~Bit 0

ADLVDH Register

Bit	7	6	5	4	3	2	1	0
Name	—	—	—	—	—	—	D9	D8
R/W	—	—	—	—	—	—	R/W	R/W
POR	—	—	—	—	—	—	0	0

Bit 7~2 Unimplemented, read as "0"

Bit 1~0 ADC Low Boundary High Byte Register Bit 9~Bit 8

ADHVDL Register

Bit	7	6	5	4	3	2	1	0
Name	D7	D6	D5	D4	D3	D2	D1	D0
R/W	R/W	R/W	R/W	R/W	R/W	R/W	R/W	R/W
POR	0	0	0	0	0	0	0	0

Bit 7~0 ADC High Boundary Low Byte Register Bit 7~Bit 0

ADHVDH Register

Bit	7	6	5	4	3	2	1	0
Name	—	—	—	—	—	—	D9	D8
R/W	—	—	—	—	—	—	R/W	R/W
POR	—	—	—	—	—	—	0	0

Bit 7~2 Unimplemented, read as "0"

Bit 1~0 ADC High Boundary High Byte Register Bit 9~Bit 8

A/D Operation

There are two ways to initiate an A/D Converter conversion cycle, selected using the ADSTS bit. The first of these is to use the ADSTR bit in the ADCR0 register used to start and reset the A/D converter. When the microcontroller program sets this bit from low to high and then low again, an analog to digital conversion cycle will be initiated. When the ADSTR bit is brought from low to high but not low again, the EOCB bit in the ADCR0 register will be set high and the analog to digital converter will be reset.

The second method of initiating a conversion is to use the PWM interrupt signal. This can be sourced from either the PWM period or duty interrupt signal, selected using the PWIS bit. If selects PWM duty interrupt signal, interrupt trigger source can be selected by PWDIS1 and PWDIS2 in the ADCR2 register. The DLSTR bit can activate a delay function which inserts a delay time between the incoming PWM interrupt signal and the actual start of the A/D conversion process, with the actual time being setup using the ADDL register. The actual delay time is calculated by the register content multiplied by the system clock period. The delay between the PWM interrupt and the start of the A/D conversion is to reduce the possibility of erroneous analog samples being taken during the time of large transient current switching by the motor drive transistors. Note that if the DLSTR bit selects no delay the ADDL register must be cleared to zero and vice-versa if the delay is selected, then a non-zero value must be programmed into the ADDL register.

The EOCB bit in the ADCR0 register is used to indicate when the analog to digital conversion process is complete. This bit will be automatically set to zero by the microcontroller after a conversion cycle has ended. In addition, the corresponding A/D interrupt request flag will be set in the interrupt control register, and if the interrupts are enabled, an appropriate internal interrupt signal will be generated. This A/D internal interrupt signal will direct the program flow to the associated A/D internal interrupt address for processing. If the A/D internal interrupt is disabled, the microcontroller can be used to poll the EOCB bit in the ADCR0 register to check whether it has been cleared as an alternative method of detecting the end of an A/D conversion cycle.

The clock source for the A/D converter, which originates from the system clock f_{SYS} , can be chosen to be either f_{SYS} or a subdivided version of f_{SYS} . The division ratio value is determined by the ADCK2~ADCK0 bits in the ADCR1 register. Although the A/D clock source is determined by the system clock, f_{SYS} , and by bits ADCK2~ADCK0, there are some limitations on the maximum A/D clock source speed that can be selected. As the minimum value of permissible A/D clock period, t_{ADCK} , is 0.2 μ s, care must be taken for system clock frequencies greater than 5MHz. For example, if the system clock operates at a frequency of 5MHz, the ADCK2~ADCK0 bits should not be set to "000" and "001". Doing so will give A/D clock periods that are less than the minimum A/D clock period which may result in inaccurate A/D conversion values.

Refer to the following table for examples, where values marked with an asterisk * show where, depending upon the device, special care must be taken, as the values may be less than the specified minimum A/D Clock Period.

f _{sys}	A/D clock Period (t _{AD})							
	ADCK2, ADCK1, ADCK0 =000 (f _{sys})	ADCK2, ADCK1, ADCK0 =001 (f _{sys} /2)	ADCK2, ADCK1, ADCK0 =010 (f _{sys} /4)	ADCK2, ADCK1, ADCK0 =011 (f _{sys} /8)	ADCK2, ADCK1, ADCK0 =100 (f _{sys} /16)	ADCK2, ADCK1, ADCK0 =101 (f _{sys} /32)	ADCK2, ADCK1, ADCK0 =110 (f _{sys} /64)	ADCK2, ADCK1, ADCK0 =111
5MHz	200ns	400ns	800ns	1.6μs	3.2μs	6.4μs	12.8μs	Undefined
10MHz	100ns*	200ns	400ns	800ns	1.6μs	3.2μs	6.4μs	Undefined
20MHz	50ns*	100ns*	200ns	400ns	800ns	1.6μs	3.2μs	Undefined

A/D Clock Period Examples

Controlling the power on/off function of the A/D converter circuitry is implemented using the ADOFF bit in the ADCR0 register. This bit must be zero to power on the A/D converter. If the ADOFF bit is zero then some power will still be consumed. In power conscious applications it is therefore recommended that the ADOFF is set high to reduce power consumption when the A/D converter function is not being used.

The boundary register pairs, ADHVDL/ADHVDH and ADLVDL/ADLVDH contain preset values which can be compared with the A/D converted values in the ADRL/ADRH registers. Various types of comparisons can be made as defined by the ADCLVE and ADCHVE bits and an interrupt generated to inform the system that either the lower or higher boundary has been exceeded. This function can be used to ensure that the motor current operates within safe working limits.

Summary of A/D Conversion Steps

The following summarises the individual steps that should be executed in order to implement an A/D conversion process.

- Step 1
Select the required A/D conversion clock by correctly programming bits ADCK2~ADCK0 in the ADCR1 register.
- Step 2
Enable the A/D by clearing the ADOFF bit in the ADCR0 register to zero.
- Step 3
Select which channel is to be connected to the internal A/D converter by correctly programming the ACS2~ACS0 bits which are also contained in the ADCR0 register.
- Step 4
Select which pins are to be used as A/D inputs and configure them by correctly programming the correct bits in the pin share registers.
- Step 5
Select which trigger circuit is to be used by correctly programming the ADSTS bits in the ADCR1.
- Step 6
If the interrupts are to be used, the interrupt control registers must be correctly configured to ensure the A/D converter interrupt function is active. The master interrupt control bit, EMI, and the A/D converter interrupt bit, AEOCE, must both be set high to do this.
- Step 7
If the step 5 selects ADSTR trigger circuit, the analog to digital conversion process can be initialised by setting the ADSTR bit in the ADCR0 register from low to high and then low again. Note that this bit should have been originally cleared to zero. If the step 5 selects PWM interrupt trigger Delay circuit, the Delay start function can be enabled by setting the DLSTR bit in the ADCR1 register.

- Step 8
 To check when the analog to digital conversion process is complete, the EOCB bit in the ADCR0 register can be polled. The conversion process is complete when this bit goes low. When this occurs the A/D data register ADRL and ADRH can be read to obtain the conversion value. As an alternative method, if the interrupts are enabled and the stack is not full, the program can wait for an A/D interrupt to occur.

Note: When checking for the end of the conversion process, if the method of polling the EOCB bit in the ADCR0 register is used, the interrupt enable step above can be omitted.

The accompanying diagram shows graphically the various stages involved in an analog to digital conversion process and its associated timing. After an A/D conversion process has been initiated by the application program, the microcontroller internal hardware will begin to carry out the conversion, during which time the program can continue with other functions. The time taken for the A/D conversion is $16t_{ADCK}$ where t_{ADCK} is equal to the A/D clock period.

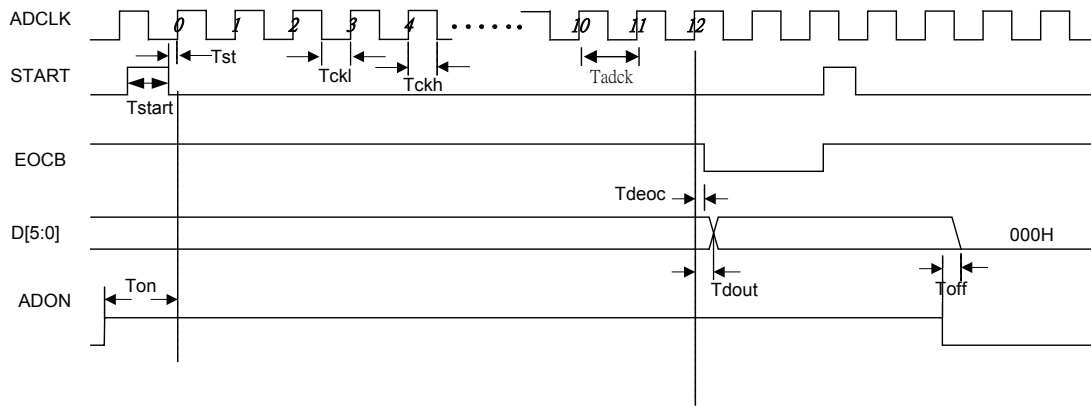

A/D Conversion Timing

Programming Considerations

During microcontroller operations where the A/D converter is not being used, the A/D internal circuitry can be switched off to reduce power consumption, by setting bit ADOFF high in the ADCR0 register. When this happens, the internal A/D converter circuits will not consume power irrespective of what analog voltage is applied to their input lines. If the A/D converter input lines are used as normal I/Os, then care must be taken as if the input voltage is not at a valid logic level, then this may lead to some increase in power consumption.

A/D Transfer Function

As the device contains a 10-bit A/D converter, its full-scale converted digitised value is equal to 3FFH. Since the full-scale analog input value is equal to the V_{DD} voltage, this gives a single bit analog input value of V_{DD} divided by 1024.

$$1 \text{ LSB} = V_{DD} / 1024$$

The A/D Converter input voltage value can be calculated using the following equation:

$$\text{A/D input voltage} = \text{A/D output digital value} \times V_{DD} / 1024$$

The diagram shows the ideal transfer function between the analog input value and the digitised output value for the A/D converter. Except for the digitised zero value, the subsequent digitised values will change at a point 0.5 LSB below where they would change without the offset, and the last full scale digitised value will change at a point 1.5 LSB below the V_{DD} level.

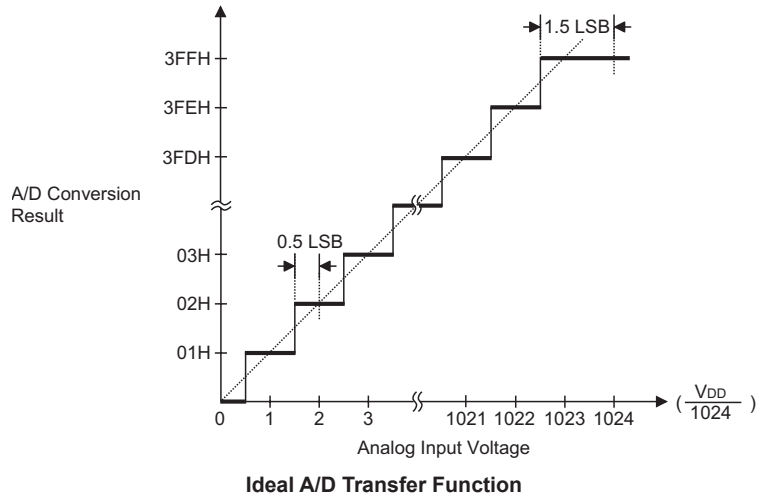

A/D Programming Examples

The following two programming examples illustrate how to setup and implement an A/D conversion. In the first example, the method of polling the EOCB bit in the ADCR0 register is used to detect when the conversion cycle is complete, whereas in the second example, the A/D interrupt is used to determine when the conversion is complete.

Example: using an EOCB polling method to detect the end of conversion

```

clr AEOCE           ; disable ADC interrupt
mov a,03H
mov ADCR1,a         ; select fsys/8 as A/D clock
clr ADOFF
mov a,0C0h         ; setup PAPS1 to configure pins AN0~AN1
mov PAPS1,a
mov a,00h
mov ADCR0           ; enable and connect AN0 channel to A/D converter
:
start_conversion:
  clr ADSTR         ; high pulse on start bit to initiate conversion
  set ADSTR         ; reset A/D
  clr ADSTR         ; start A/D
polling_EOC:
  sz EOCB           ; poll the ADCR0 register EOCB bit to detect end
                    ; of A/D conversion
  jmp polling_EOC  ; continue polling
  mov a,ADRL        ; read low byte conversion result value
  mov ADRL_buffer,a ; save result to user defined register
  mov a,ADRH        ; read high byte conversion result value
  mov ADRH_buffer,a ; save result to user defined register
:
:
jmp start_conversion ; start next a/d conversion

```

xample: using the interrupt method to detect the end of conversion

```
clr MF1E ; disable ADC interrupt
clr AEOCE
mov a,03H
mov ADCR1,a ; select fsys/8 as A/D clock
clr ADOFF
mov a,0C0h ; setup PAPS1 to configure pins AN0~AN1
mov PAPS1,a
mov a,00h
mov ADCR0,a ; enable and connect AN0 channel to A/D converter
Start_conversion:
clr ADSTR ; high pulse on START bit to initiate conversion
set ADSTR ; reset A/D
clr ADSTR ; start A/D
clr AEOCF ; clear ADC interrupt request flag
set AEOCE ; enable ADC interrupt
set MF1E ; enable Multi_interrupt 1
set EMI ; enable global interrupt
:
:
; ADC interrupt service routine
ADC_ISR:
mov acc_stack,a ; save ACC to user defined memory
mov a,STATUS
mov status_stack,a ; save STATUS to user defined memory
:
:
mov a,ADRL ; read low byte conversion result value
mov adrl_buffer,a ; save result to user defined register
mov a,ADRH ; read high byte conversion result value
mov adrh_buffer,a ; save result to user defined register
:
:
EXIT_INT_ISR:
mov a,status_stack
mov STATUS,a ; restore STATUS from user defined memory
mov a,acc_stack ; restore ACC from user defined memory
reti
```

Over-current Detection

The device contains an fully integrated over-current detect circuit which is used for motor protection.

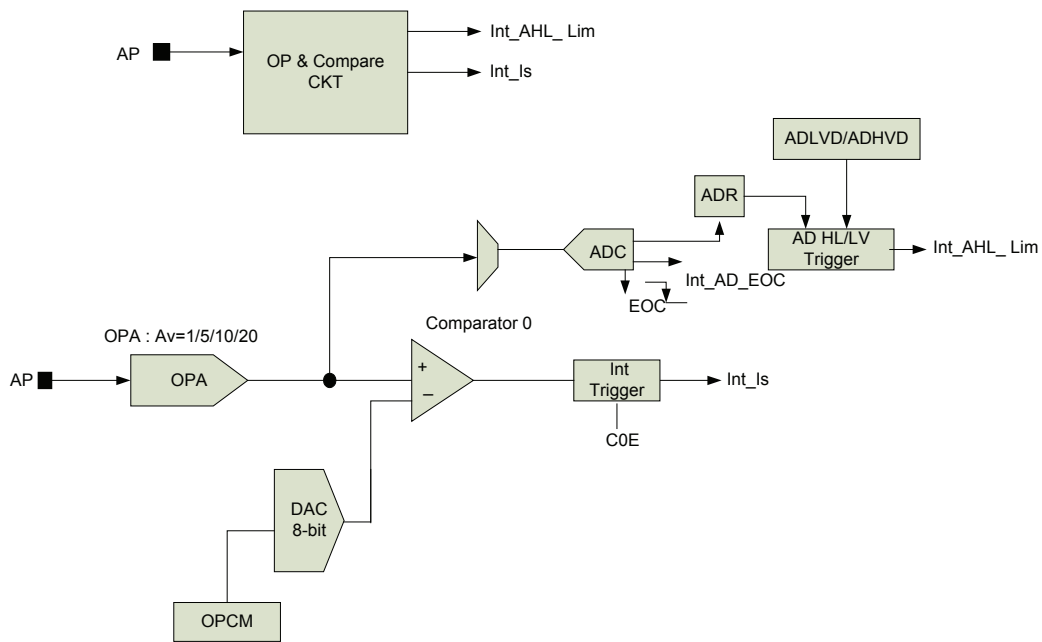

Over-current Detector Block Diagram

Over-current Functional Description

The over-current functional block includes an amplifier, 10-bit A/D Converter, 8-bit D/A Converter and comparator. If an over-current situation is detected then the motor external drive circuit can be switched off immediately to prevent damage to the motor. Two kinds of interrupts are generated which can be used for over-current detection.

- A/D Converter interrupt - Int_AHL_Lim
- Comparator 0 interrupt - Int_Is

Over-current Register Description

There are three registers to control the function and operation of the over current detection circuits, known as OPOMS, OPCM and OPACAL. These 8-bit registers define functions such as the OPA operation mode selection, OPA calibration and comparison. OPCM is an 8-bit DAC register used for OPA comparison.

OPOMS Register

Bit	7	6	5	4	3	2	1	0
Name	CMP0_EG1	CMP0_EG0	—	—	—	OPAVS2	OPAVS1	OPAVS0
R/W	R/W	R/W	—	—	—	R/W	R/W	R/W
POR	0	0	—	—	—	0	1	0

Bit 7~6 **CMP0_EG1~CMP0_EG0**: Defines Comparator active edge

00: Disable Comparator 0 and DAC

01: Rising edge

10: Falling edge

11: Dual edge

Bit 5~3 Unimplemented, read as "0"

Bit 2~0 **OPAVS2~OPAVS0**: OPA Av mode select

000: Disable OPA

001: Av=5

010: Av=10

011: Av=20

111: AV=1

Note: It is need to enable AN2/AP by setting pin share register when using OPA function.

OPCM Register

Bit	7	6	5	4	3	2	1	0
Name	D7	D6	D5	D4	D3	D2	D1	D0
R/W	R/W	R/W	R/W	R/W	R/W	R/W	R/W	R/W
POR	0	0	0	0	0	0	0	0

Bit 7~0 8-bit OPA comparison register bit 7 ~ bit 0

OPACAL Register

Bit	7	6	5	4	3	2	1	0
Name	—	ARS	AOFM	AOF4	AOF3	AOF2	AOF1	AOF0
R/W	—	R/W	R/W	R/W	R/W	R/W	R/W	R/W
POR	—	0	0	1	0	0	0	0

Bit 7 Unimplemented, read as "0"

Bit 6 **ARS**: Comparator input offset calibration reference select

0: Comparator negative input

1: Comparator positive input

Bit 5 **AOFM**: Normal or Calibration Mode select

0: Opamp or Comparator Mode

1: Offset Calibration Mode

Bit 4~0 **AOF4~AOF0**: Comparator input offset voltage calibration control

00000: Minimum

10000: Center

11111: Maximum

BLDC Motor Control Circuit

This section describes how the device can be used to control Brushless DC Motors, otherwise known as BLDC Motors. Its high level of functional integration and flexibility offer a full range of driving features for motor driving.

Functional Description

The PWM counter circuit output PWMO is has an adjustable PWM Duty to control the output motor power thus controlling the motor speed. Changing the PWM frequency can be used to enhance the motor drive efficiency or to reduce noise and resonance generated during physical motor operation.

The internal Mask circuit is used to determine which PWM modulation signals are enabled or disabled for the motor speed control. The PWM modulation signal can be output both the upper arms, GAT/GBT/GCT and the lower arms, GAB/GBB/GCB, of the external Gate Driver Transistor Pairs under software control.

The Dead-Time insertion circuit is used to ensure the upper and lower Gate Driver Transistor Pairs are not enabled simultaneously to prevent the occurrence of a virtual power short circuit. The dead time is selected under software control.

The Staggered circuit can force all the outputs to an off status if the software detects an error condition which could be due to external factors such as ESD problems or both upper and lower external Gate Driver Transistor pairs being simultaneously on. The Polarity circuit can select the output polarity of the BLDC motor output control port to support many different types of external MOS gate drive device circuit combinations.

The Motor Protect circuit includes many detection circuits for functions such as a motor stall condition, over current protection, external edge triggered Pause pin, external level trigger Fault pin etc. The Hall Sensor Decoder circuit is a six-step system which can be used control the motor direction.

Twelve registers, each using 6 bits, are used to control the direction of the motor. The motor forward, backward, brake and free functions are controlled by the HDCD/HDCR registers. The HA/HB/HC or SHA/SHB/SHC can be selected as the Hall Sensor Decoder circuit inputs.

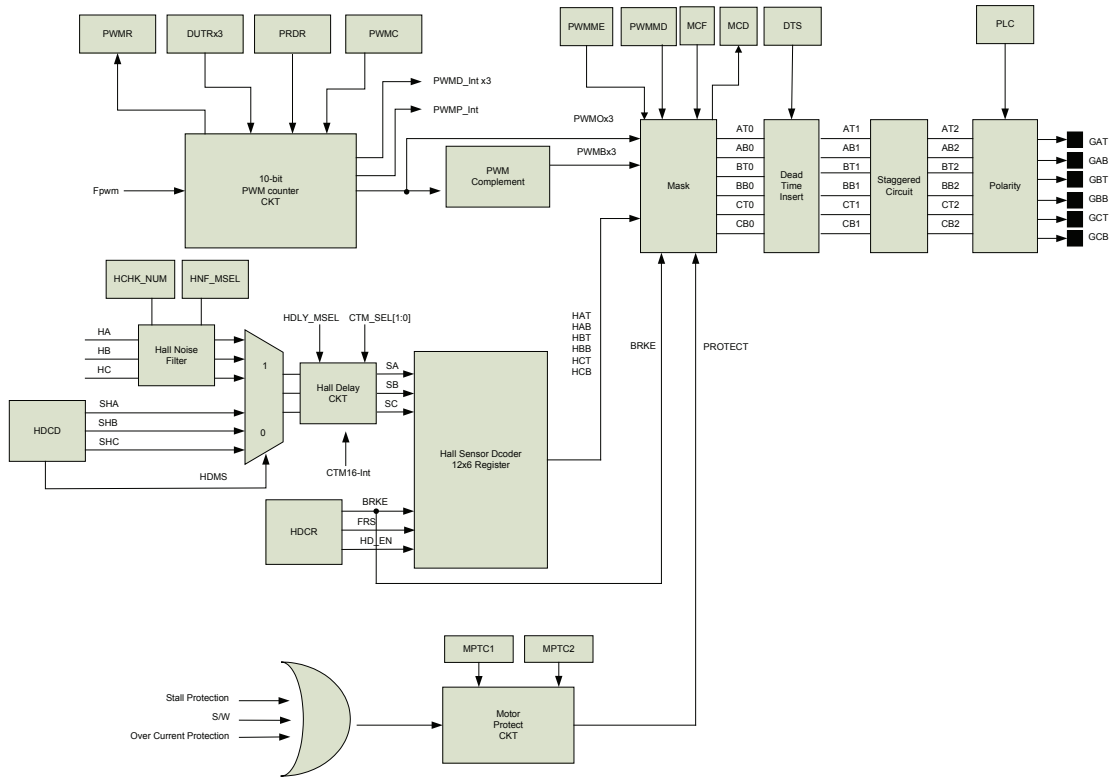

BLDC Motor Control Block Diagram

Note: GAT, GAB, GBT, GBB, GCT, GCB == PWM0H, PWM0L, PWM1H, PWM1L, PWM2H, PWM2L.

PWM Counter Control Circuit

The device includes a 10-bit PWM generator. The PWM signal has both adjustable duty cycle and frequency that can be setup by programming 10-bit values into the corresponding PWM registers.

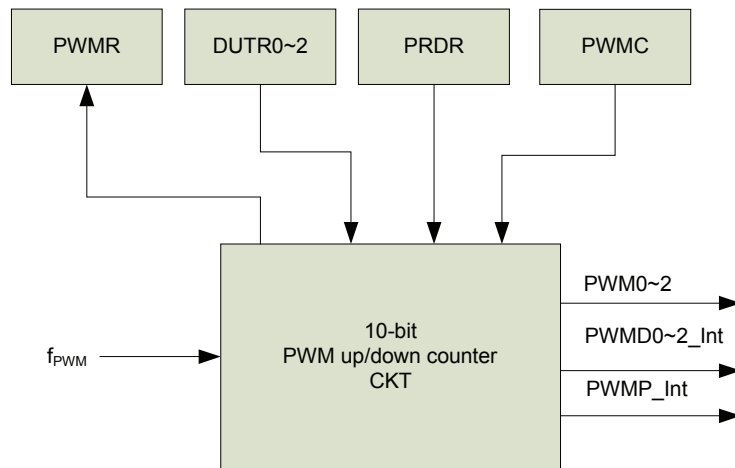

PWM Block Diagram

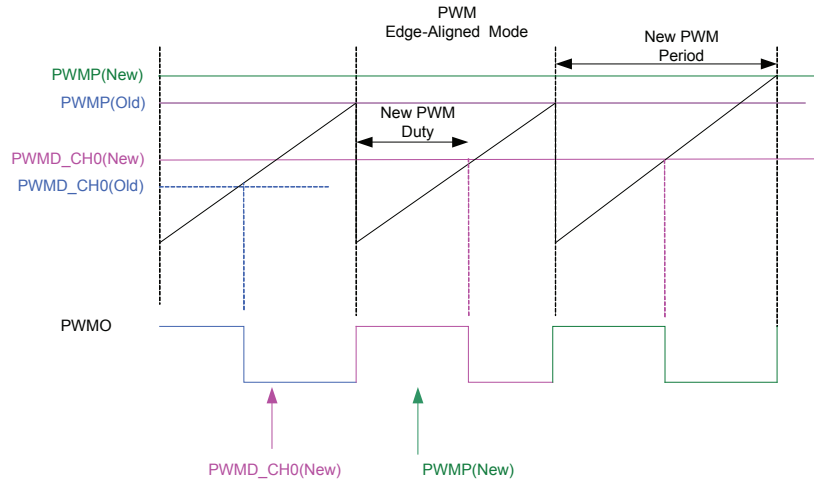

PWM Edge-Aligned mode Timing Diagram

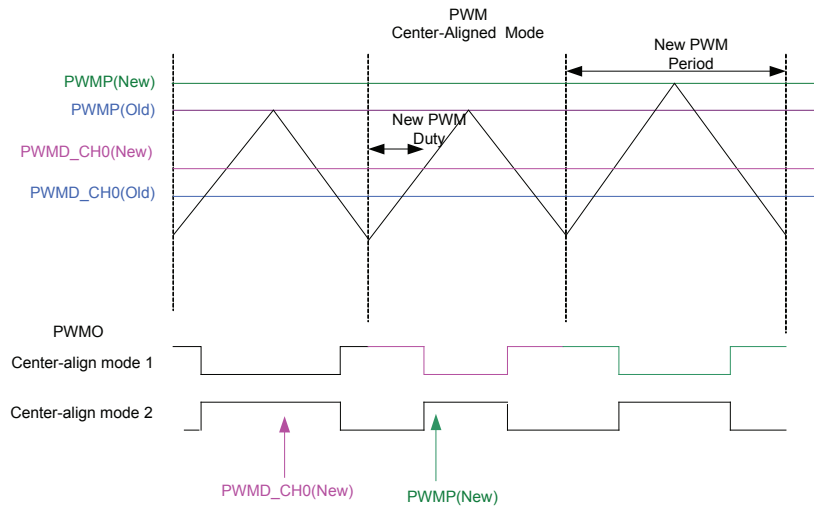

PWM Center-Aligned mode Timing Diagram

PWM Register Description

Overall PWM operation is controlled by a series of registers. The DUTRnL/DUTRnH register pair is used for PWM duty control for adjustment of the motor output power. The PRDRL/PRDRH register pair are used together to form a 10-bit value to setup the PWM period for PWM Frequency adjustment. Being able to change the PWM frequency is useful for motor characteristic matching for problems such as noise reduction and resonance. The PWMRL/PWMRH registers are used to monitor the PWM counter dynamically. The PWMON bit in the PWMC register is the 10-bit PWM counter on/off bit. The PWM clock source for the PWM counter can be selected by PCKS1~PCKS0 bits in the PWMC register. The PWMMS bits in the PWMC register determine the PWM alignment type, which can be either edge or centre type. It should be noted that the order of writing data to PWM register is MSB.

• **PWMC Register**

Bit	7	6	5	4	3	2	1	0
Name	PWMMS1	PWMMS0	PCKS1	PCKS0	PWMON	ITCMS1	ITCMS0	PWMLD
R/W	R/W	R/W	R/W	R/W	R/W	R/W	R/W	R/W
POR	0	0	0	0	0	0	0	0

Bit 7~6 **PWMMS**: PWM mode select bit
 0x: Edge-aligned mode,
 10: Centre-aligned mode 1
 11: Centre-aligned mode 2

Bit 5~4 **PCKS1, PCKS0**: Clock source of the PWM counter select
 000: f_{PWM} , PWM frequency Min.=20kHz, f_{PWM} base on 20MHz
 001: $f_{PWM}/2$, PWM frequency Min.=10kHz
 010: $f_{PWM}/4$, PWM frequency Min.=5kHz
 011: $f_{PWM}/8$, PWM frequency Min.=2.5kHz

Bit 3 **PWMON**: PWM Circuit On/Off control
 0: Off
 1: On

This bit controls the overall on/off function of the PWM. Setting the bit high enables the counter to run, clearing the bit disables the PWM. Clearing this bit to zero will stop the counter from counting and turn off the PWM which will reduce its power consumption.

Bit 2~1 **ITCMS1~ITCMS0**:
 00: disable center-aligned mode duty interrupt
 01: center-aligned mode duty interrupt only in counter up condition
 10: center-aligned mode duty interrupt only in counter down condition
 11: center-aligned mode duty interrupt both in counter up or down condition

Bit 0 **PWMLD**: PWM PRDR&DUTRx,x=0~2 register update bit
 0: The registers value of PRDR and DUTRx, x=0~2 are never loaded to counter and Comparator registers.
 1: The PRDR register will be load value to counter register after counter underflow, and hardware will clear by next clock cycle.

• **DUTR0L Register**

Bit	7	6	5	4	3	2	1	0
Name	D7	D6	D5	D4	D3	D2	D1	D0
R/W	R/W	R/W	R/W	R/W	R/W	R/W	R/W	R/W
POR	0	0	0	0	0	0	0	0

Bit 7~0 10-bit PWM0 Duty register low byte register
 10-bit DUTR0 register bit 7 ~ bit 0

• **DUTR0H Register**

Bit	7	6	5	4	3	2	1	0
Name	—	—	—	—	—	—	D9	D8
R/W	—	—	—	—	—	—	R/W	R/W
POR	—	—	—	—	—	—	0	0

Bit 7~2 Unimplemented, read as "0"

Bit 1~0 10-bit PWM0 Duty register high byte register
 10-bit DUTR0 register bit 9 ~ bit 8

• **DUTR1L Register**

Bit	7	6	5	4	3	2	1	0
Name	D7	D6	D5	D4	D3	D2	D1	D0
R/W	R/W	R/W	R/W	R/W	R/W	R/W	R/W	R/W
POR	0	0	0	0	0	0	0	0

Bit 7~0 10-bit PWM1 Duty register low byte register
10-bit DUTR1 register bit 7 ~ bit 0

• **DUTR1H Register**

Bit	7	6	5	4	3	2	1	0
Name	—	—	—	—	—	—	D9	D8
R/W	—	—	—	—	—	—	R/W	R/W
POR	—	—	—	—	—	—	0	0

Bit 7~2 Unimplemented, read as "0"
Bit 1~0 10-bit PWM1 Duty register high byte register
10-bit DUTR1 register bit 9 ~ bit 8

• **DUTR2L Register**

Bit	7	6	5	4	3	2	1	0
Name	D7	D6	D5	D4	D3	D2	D1	D0
R/W	R/W	R/W	R/W	R/W	R/W	R/W	R/W	R/W
POR	0	0	0	0	0	0	0	0

Bit 7~0 10-bit PWM2 Duty register low byte register
10-bit DUTR2 register bit 7 ~ bit 0

• **DUTR2H Register**

Bit	7	6	5	4	3	2	1	0
Name	—	—	—	—	—	—	D9	D8
R/W	—	—	—	—	—	—	R/W	R/W
POR	—	—	—	—	—	—	0	0

Bit 7~2 Unimplemented, read as "0"
Bit 1~0 10-bit PWM2 Duty register high byte register
10-bit DUTR2 register bit 9 ~ bit 8

• **PRDRL Register**

Bit	7	6	5	4	3	2	1	0
Name	D7	D6	D5	D4	D3	D2	D1	D0
R/W	R/W	R/W	R/W	R/W	R/W	R/W	R/W	R/W
POR	0	0	0	0	0	0	0	0

Bit 7~0 10-bit PWM Period register low byte register
10-bit PRDR register bit 7 ~ bit 0

• **PRDRH Register**

Bit	7	6	5	4	3	2	1	0
Name	—	—	—	—	—	—	D9	D8
R/W	—	—	—	—	—	—	R/W	R/W
POR	—	—	—	—	—	—	0	0

Bit 7~2 Unimplemented, read as "0"
Bit 1~0 10-bit PWM Period register high byte register
10-bit PRDR register bit 9 ~ bit 8

• **PWMRL Register**

Bit	7	6	5	4	3	2	1	0
Name	D7	D6	D5	D4	D3	D2	D1	D0
R/W	R	R	R	R	R	R	R	R
POR	0	0	0	0	0	0	0	0

Bit 7~0 10-bit PWM counter register low byte register
 10-bit PWM counter bit 7 ~ bit 0

• **PWMRH Register**

Bit	7	6	5	4	3	2	1	0
Name	—	—	—	—	—	—	D9	D8
R/W	—	—	—	—	—	—	R	R
POR	—	—	—	—	—	—	0	0

Bit 7~2 Unimplemented, read as "0"
 Bit 1~0 10-bit PWM Counter high byte register
 10-bit PWM Counter bit 9 ~ bit 8

Mask Function

The device includes a Motor Control Mask Function for increased control flexibility.

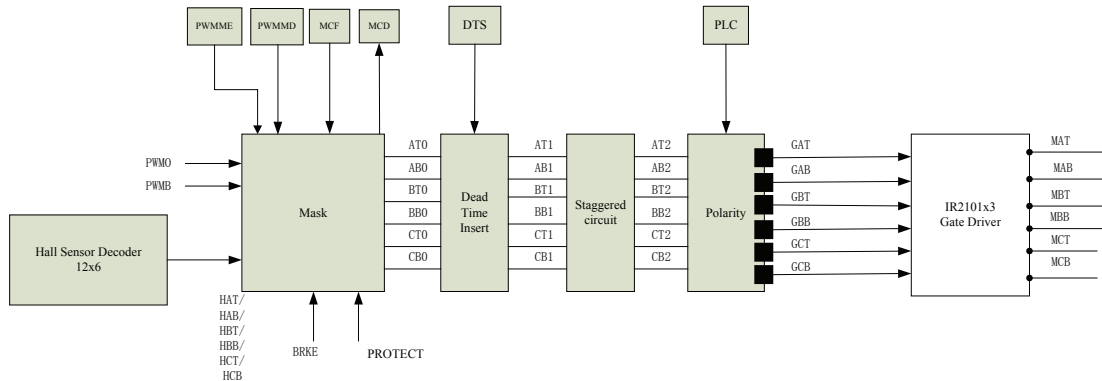

Mask Function Block Diagram

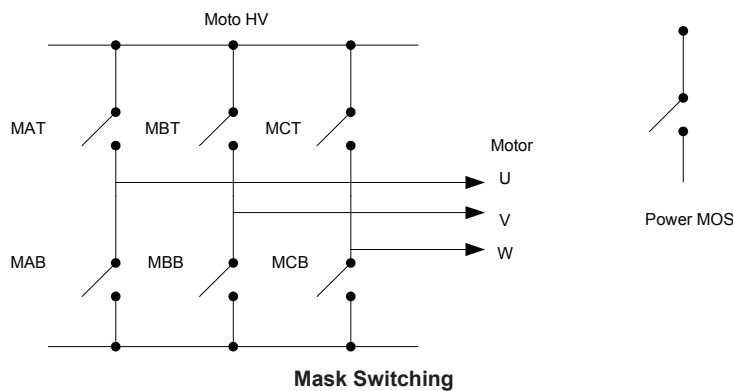

Mask Switching

Functional Description

The internal MASK circuit has three operation modes, which are known as the Normal Mode, Brake Mode and Motor Protect Mode.

- **Normal Mode**

In the Normal Mode, the motor speed control method is determined by the PWMS/MPWE bits in the MCF register.

When PWMS =0, the bottom port PWM output selects transistor pair bottom arm GAB/ GBB/ GCB.

When PWMS =1, the top port PWM output selects transistor pair top arm, GAT/ GBT/ GCT.

When MPWE =0, the PWM output is disabled and AT0/BT0/CT0/AB0/BB0/CB0 are all on.

When MPWE =1, the PWM output is enabled and AT0/BT0/CT0/AB0/BB0/CB0 can output a variable PWM signal for speed control.

When MPWMS=0, the PWM has a Complementary output.

When MPWMS=1, the PWM has a Non-complementary output.

MSKMS=0: the Mask Mode selects H/W.

MSKMS=1: the Mask Mode selects S/W.

- **H/W Mask Mode**

Complementary control, MPWMS=0

	HAT	HAB	AT0	AB0		HAT	HAB	AT0	AB0
	PWMS=0	0	0	0		0	PWMS=1	0	0
0		1	PWMB	PWMO	0	1		0	1
1		0	1	0	1	0		PWMO	PWMB
1		1	0	0	1	1		0	0

	HBT	HBB	BT0	BB0		HBT	HBB	BT0	BB0
	PWMS=0	0	0	0		0	PWMS=1	0	0
0		1	PWMB	PWMO	0	1		0	1
1		0	1	0	1	0		PWMO	PWMB
1		1	0	0	1	1		0	0

	HCT	HCB	CT0	CB0		HCT	HCB	CT0	CB0
	PWMS=0	0	0	0		0	PWMS=1	0	0
0		1	PWMB	PWMO	0	1		0	1
1		0	1	0	1	0		PWMO	PWMB
1		1	0	0	1	1		0	0

Non-complementary control, MPWMS=1

	HAT	HAB	AT0	AB0		HAT	HAB	AT0	AB0
	PWMS=0	0	0	0		0	PWMS=1	0	0
0		1	0	PWMO	0	1		0	1
1		0	1	0	1	0		PWMO	0
1		1	0	0	1	1		0	0

	HBT	HBB	BT0	BB0		HBT	HBB	BT0	BB0		
	PWMS=0	0	0	0		0	PWMS=1	0	0	0	0
		0	1	0		PWMO		0	1	0	1
		1	0	1		0		1	0	PWMO	0
		1	1	0		0		1	1	0	0

	HCT	HCB	CT0	CB0		HCT	HCB	CT0	CB0		
	PWMS=0	0	0	0		0	PWMS=1	0	0	0	0
		0	1	0		PWMO		0	1	0	1
		1	0	1		0		1	0	PWMO	0
		1	1	0		0		1	1	0	0

• S/W Mask Mode

To control the Mask circuit, two registers known as PWMME, PWMMD, MCF and MCD are provided. PWMME register is used for control PWM signal and PWMMD is used to determine the MOS Gate Driver Circuit is on or off. Note that Setting PWMS and MPWMS or anything related to PWM function is effective to H/W or S/W mode.

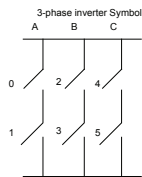

Mask Complement Mode Example

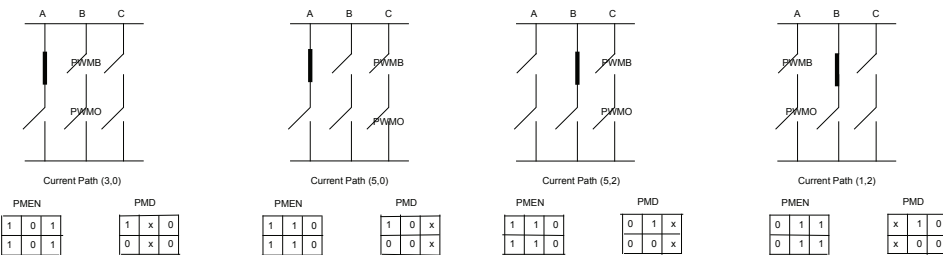

Mask Independent Mode Example

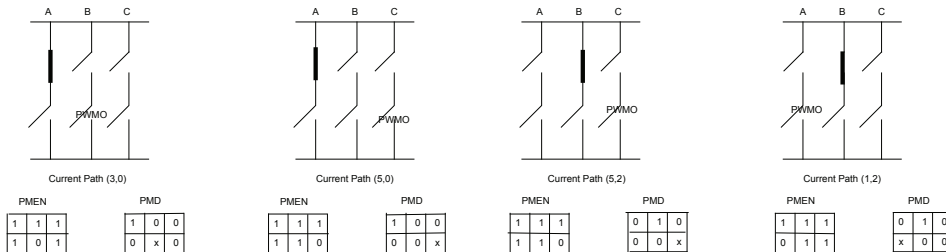

Mask S/W Mode circuit

- Note: 1. During masking enabled, when PWMxH and PWMxL are masked simultaneously, the two pins of each pair can not be set to "1" simultaneously, PMD.0 and PMD.1, PMD.2 and PMD.3, PMD.4 and PMD.5. If they are all high in the same time, switch 2n and switch 2n+1 will output "0".
2. If PWM and complementary PWM are enabled simultaneously, one of the two registers PWMxH and PWMxL output PWM and the other one can not be masked to "1" but output "0" automatically by hardware.
3. If the PWMxH and PWMxL are configured as I/O function, then PWM MASK function will be invalid.

S/W Mask Register Description

- **PWMME Register**

Bit	7	6	5	4	3	2	1	0
Name	—	—	PME5	PME4	PME3	PME2	PME1	PME0
R/W	—	—	R/W	R/W	R/W	R/W	R/W	R/W
POR	—	—	0	0	0	0	0	0

bit 7~6 unimplemented, read as"0"

bit 5~0 **PME5~PME0:** PWM Mask enable register

0: PWM generator signal is output to next stage.

1: PWM generator signal is masked and PMDn is output to next stage.

The PWM generator signal will be masked when this bit is enabled. The corresponding PWMn channel will be output with PMD.n data.

- **PWMD Register**

Bit	7	6	5	4	3	2	1	0
Name	—	—	PMD5	PMD4	PMD3	PMD2	PMD1	PMD0
R/W	—	—	R/W	R/W	R/W	R/W	R/W	R/W
POR	—	—	0	0	0	0	0	0

bit 7~6 unimplemented, read as"0"

bit 5-0 **PMD5~PMD0:** PWM Mask Data bit

0: Output logic low to PWMn.

1: Output logic high to PWMn.

This data bit control the state of PWMn output pin, if corresponding PMEn = 1.

- **Brake Mode**

The Brake Mode has the highest priority. When activated, the external Gate Driver Transistor Pair Top arm will be off and the Bottom arm will be on. The Brake Truth decode table is shown below.

BRKE=1	AT0	BT0	CT0	AB0	BB0	CB0
	0	0	0	1	1	1

- **Motor Protect Mode**

When the Motor Protect Mode is activated, the external Gate Driver Transistor Pair can select the brake, where the top arm is off and the bottom arm is on, or select free running where the top and bottom arm are both off. The protection decode table is shown below.

PROTECT =1	GAT	GBT	GCT	GAB	GBB	GCB
FMOS=0	0	0	0	0	0	0
FMOS=1	0	0	0	1	1	1

For 6-Step communication, if the U winding and W winding are on then turn off the V winding.

If GAT =1 and GAB =0, turn on the U winding

If GBT =0 and GBB =0, turn off the V Winding.

If GCT=PWMD and GCB=PWM, turn on the W winding and adjust the output power of the motor using the DUTR register to control the speed.

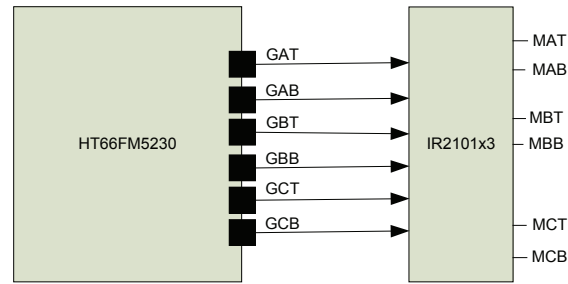

Drive Signal Block Diagram

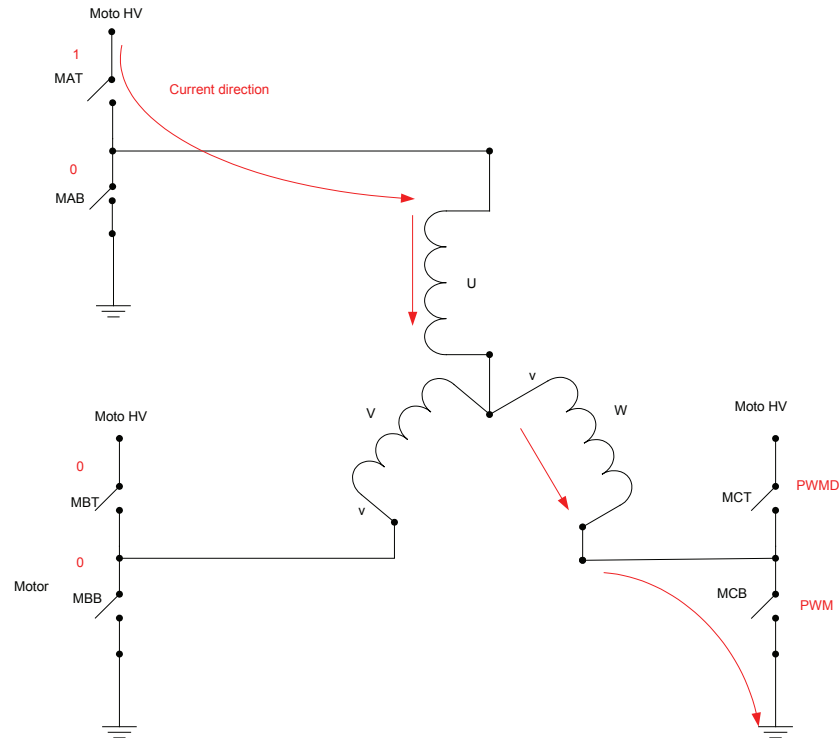

Motor Winding Connection

Register Description

The device has two registers connected with the Mask Function control. These are the MCF register which is used for control and the MCD register which is used to read the status of the gate driver outputs.

• **MCF Register**

Bit	7	6	5	4	3	2	1	0
Name	MSKMS	—	—	—	MPWMS	MPWE	FMOS	PWMS
R	R/W	—	—	—	R/W	R/W	R/W	R/W
POR	0	—	—	—	0	1	0	0

- bit 7 **MSKMS:** Mask Mode Select
 0: H/W Mask Mode
 1: S/W Mask Mode
- bit 6~4 unimplemented, read as"0"
- Bit 3 **MPWMS:** Mask PWM Mode select
 0: Complementary
 1: Non-complementary

- Bit 2 **MPWE:** PWM output control
 0: PWM output disable (AT0/BT0/CT0/AB0/BB0/CB0 can not output PWM)
 1: PWM output enable (AT0/BT0/CT0/AB0/BB0/CB0 can output PWM to control speed)
- Bit 1 **FMOS:** Fault Mask output select
 0: AT0/BT0/CT0=0, AB0/BB0/CB0=0
 1: AT0/BT0/CT0=0, AB0/BB0/CB0=1
- Bit 0 **PWMS:** Top port/Bottom port PWM select
 0: Select Bottom port PWM output
 1: Select Top port PWM output

• **MCD Register**

Bit	7	6	5	4	3	2	1	0
Name	—	—	GAT	GAB	GBT	FHC	FHB	FHA
R/W	—	—	R	R	R	R	R	R
POR	—	—	0	0	0	0	0	0

- bit 7~6 unimplemented, read as"0"
- Bit 5~3 **GAT/GAB/GBT:** Gate diver output monitor
- Bit 2~0 **FHC/FHB/FHA:** HC/HB/HA filtered outputs
 These signals are derived from the HC/HB/HA signals and filtered by the Hall Noise Filter.

Other Functions

Several other functions exist for additional motor control drive signal flexibility. These are the Dead Time Function, Staggered Function and Polarity Function.

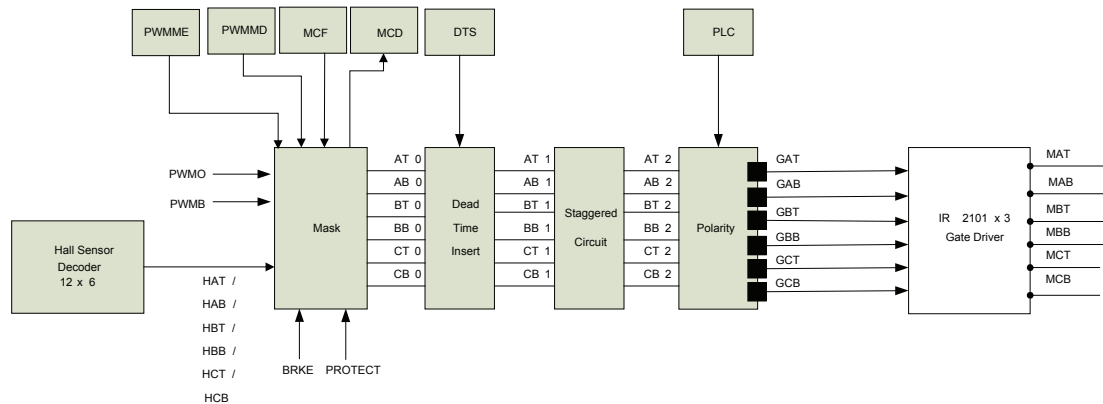

Dead Time, Staggered and Polarity Function Block Diagram

Dead Time Function

During transistor pair switching, the Dead Time function is used to prevent both upper and lower transistor pairs from conducting at the same time thus preventing a virtual short circuit condition from occurring. The actual dead time value can be setup to be within a value from 0.3µs to 5µs which is selected by the application program.

The Dead Time Insertion circuit requires six independent output circuits:

When the AT0/AB0/BT0/BB0/CT0/CB0 outputs experience a rising edge, then a Dead Time is inserted.

When the AT0/AB0/BT0/BB0/CT0/CB0 outputs experience a falling edge, then the outputs remain unchanged.

The Dead-Time Insertion Circuit is only during motor control. The Dead Time function is enabled/disabled by the DTE bit in the DTS register.

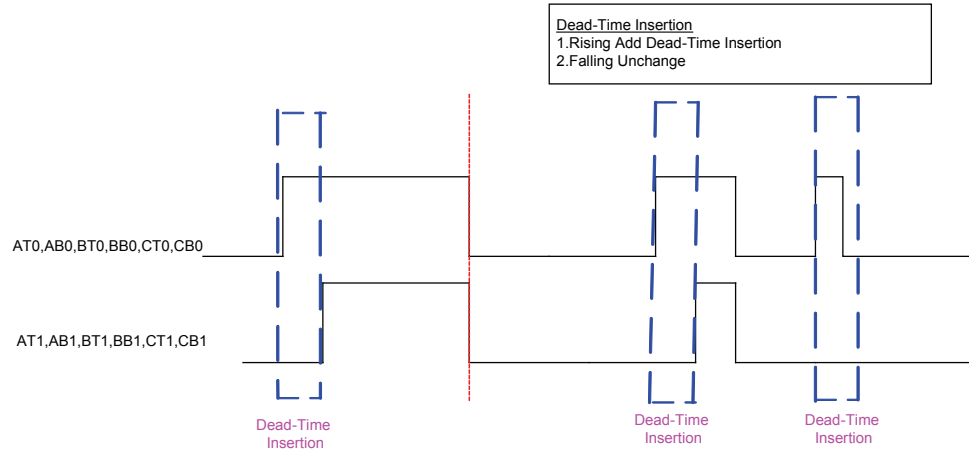

Dead Time Insertion Timing

A single register, DTS, is dedicated for use by the Dead Time function.

• **DTS Register**

Bit	7	6	5	4	3	2	1	0
Name	DTCKS1	DTCKS0	DTE	D4	D3	D2	D1	D0
R/W	R/W	R/W	R/W	R/W	R/W	R/W	R/W	R/W
POR	0	0	0	0	0	0	0	0

bit 7~6 **DTCKS1, DTCKS0:** Dead-Time clock source selection
 00: f_{DT} is f_{SYS} , f_{SYS} based on 20MHz
 01: f_{DT} is $f_{SYS}/2$
 10: f_{DT} is $f_{SYS}/4$
 11: f_{DT} is $f_{SYS}/8$

Bit 5 **DTE:** Dead Time Enable
 0: Dead-Time=0
 1: Dead-Time = $(DTS[4:0]+1)/f_{DT}$

Bit 4~0 **D4~D0:** Dead Time Register bit 4 ~ bit 0
 Dead-Time counter. 5-bit Dead-Time value bits for Dead-Time Unit.
 Dead-Time = $(DTS[4:0]+1)/f_{DT}$

Staggered Function

The Staggered Function is used to force all output drive transistors to an off condition when a software error occurs or due to external factors such as ESD.

AT1	AB1	AT2	AB2
0	0	0	0
0	1	0	1
1	0	1	0
1	1	0	0

The default condition for the BLDC motor control circuit is designed for default N-type transistor pairs. This means a "1" value will switch the transistor on and a "0" value will switch it off.

Polarity Function

This function allows setup of the external gate drive transistor On/Off polarity status. A single register, PLC, is used for overall control.

• **PLC Register**

Bit	7	6	5	4	3	2	1	0
Name	—	—	PCBC	PCTC	PBBC	PBTC	PABC	PATC
R/W	—	—	R/W	R/W	R/W	R/W	R/W	R/W
POR	—	—	0	0	0	0	0	0

- Bit 7~6 Unimplemented, read as "0"
- Bit 5 **PCBC**: C pair Bottom port Gate output inverse control
- Bit 4 **PCTC**: C pair Top port Gate output inverse control
- Bit 3 **PBBC**: B pair Bottom port Gate output inverse control
- Bit 2 **PBTC**: B pair Top port Gate output inverse control
- Bit 1 **PABC**: A pair Bottom port Gate output inverse control
- Bit 0 **PATC**: A pair Top port Gate output inverse control

Bit Value	Status
0	Output not inverted
1	Output inverted

PLC Register Values

Note that the default output pin GAT/GAB/GBT/GBB/GCT/GCB status is high impedance.

Hall Sensor Decoder

This device contains a fully integrated Hall Sensor decoder function which interfaces to the Hall Sensors in the BLDC motor for directional and speed control.

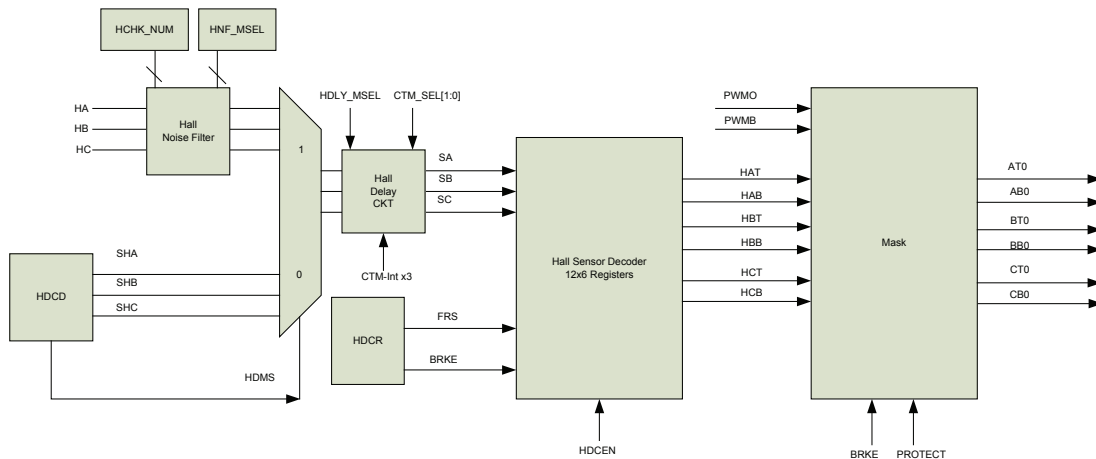

Hall Sensor Decoder Block Diagram

The Hall Sensor input signals are selected by setting the HDMS bit high. If the HDMS bit is zero then SHA/SHB/SHC will be used instead of the actual Hall Sensor signals.

Hall Sensor Noise Filter

This device includes a Hall Noise Filter function to filter out the effects of noise generated by the large switching currents of the motor driver. This generated noise may affect the Hall Sensor inputs (H1/H2/H3), which in turn may result in incorrect Hall Sensor output decoding.

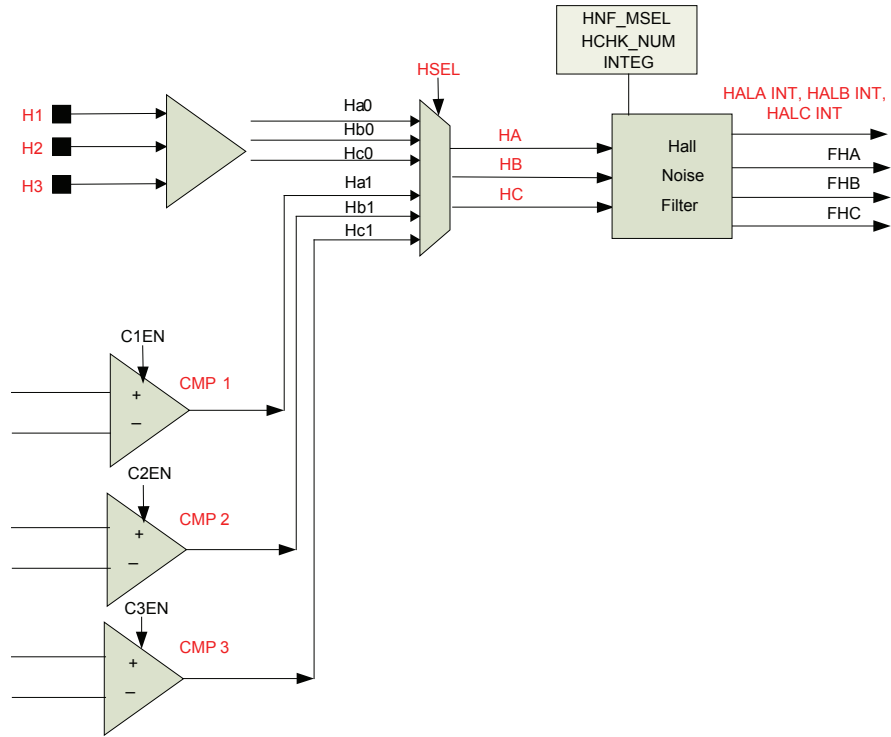

Hall Sensor Noise Filter Block Diagram

Several registers are used to control the noise filter. The HNF_EN bit in the HNF_MSEL register is used as the overall enable/disable bit for the noise filter. It is necessary to enable CMP1, CMP2 and CMP3 hysteresis function before the comparators are used during motor control sensorless applications.

HNF_EN bit	Status
0	Noise Filter Off – HA/HB/HC not used
1	Noise Filter On

Hall Sensor Noise Filter Enable

The sampling frequency of the Hall noise filter is setup using the HFR_SEL [3:0] bits.

The HCHK_NUM [4:0] bits are used to setup the Hall Sensor input compare numbers.

$HCHK_NUM [4:0] \times \text{Sampling space} = \text{Anti-noise ability} = \text{Hall Delay-Time}$.

It should be noted that longer Hall delay times will result in higher rotor speed feedback signal distortion.

Hall Sensor Delay Function

The Hall sensor function in the device includes a Hall delay function which can implement a signal phase forward or phase backward operation. The following steps, which should be executed before the Hall Decoder is enabled, show how this function is activated.

- Step 1
Set the Hall Decode table to select either the phase forward or phase backward function.
- Step 2
Select which TM is used to generate the Delay Time and set the selected TM to run in the Compare Match Mode by programming the CTM_SEL1~CTM_SEL0 bits.
- Step 3
Use the HDLY_MSEL bit to select the Hall Delay circuit operating mode. The default value of HDLY_MSEL is zero which will disable the Hall Delay circuit. If the HDLY_MSEL bit is set high, then the Hall Delay circuit will be enabled.
- Step 4
Enable the Hall Decoder using the HDCEN bit.

The following points should be noted regarding the HDLY_MSEL bit.

- When this bit is low, BUF1[2:0] and BUF2[2:0] will be cleared to zero.
- When this bit is low, TM0/TM1/TM2 retain their original TM functions.
- When the bit is high, the TM which is selected by the Delay function will be dedicated for use by the Hall Delay circuit.

The original TM functions will still remain active except for the TnON bit which will be controlled automatically by the hardware.

With regard to the TM functions the following steps should be taken before the Delay function is enabled.

- Keep TnON and TnPAU = 0
- The TM should be setup in the Compare Match Mode
- TnCCLR=1, therefore the TM is cleared with a comparator A match condition.
- Setup the Delay time using TMnA and TnCKx.

After the Delay function is enabled, HDLY_MSEL will change from low to high. The Delay time must not be more than one step time of the Hall input, which has six steps, otherwise the output can not be anticipated, will drop out of step.

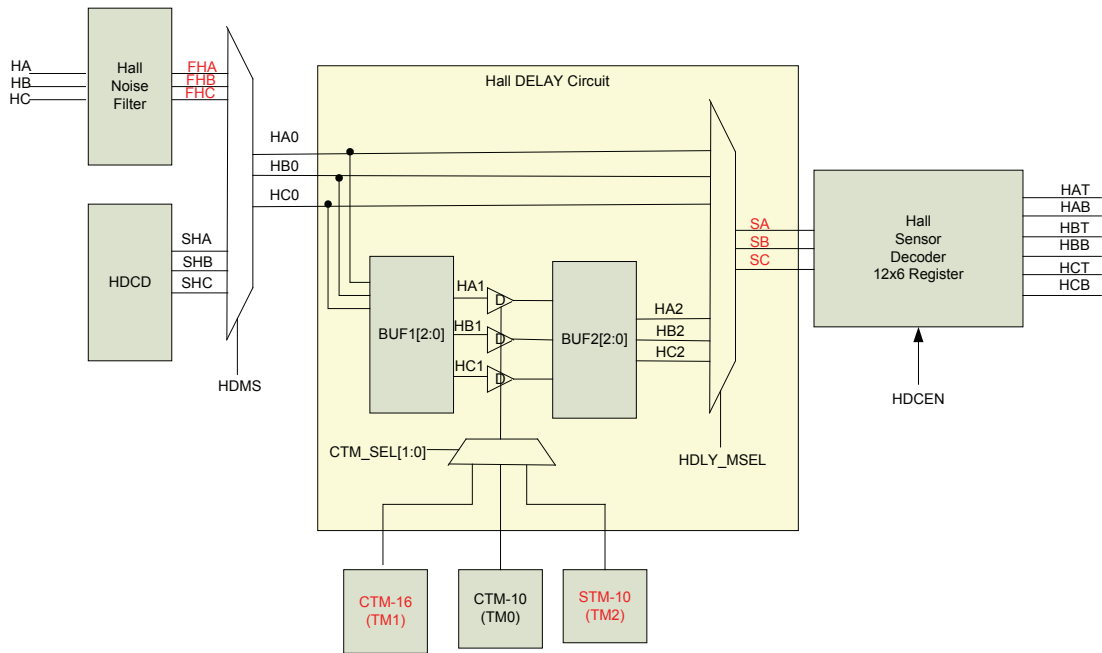

Delay Function Block Diagram

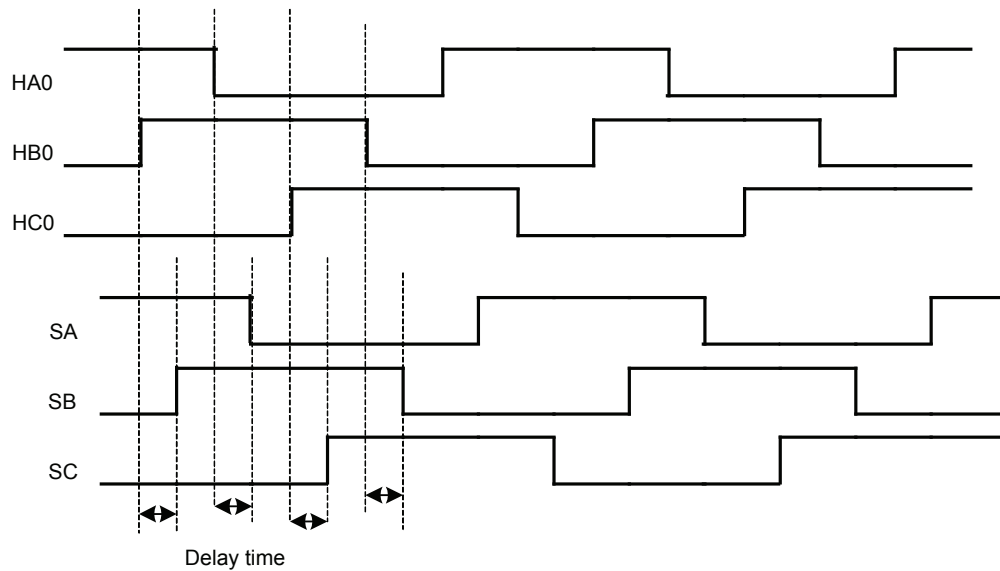

Delay Function Timing

Motor Control Drive Signals

The direction of the BLDC motor is controlled using the HDCR, HDCD registers and a series of HDCT registers, HDCT0~HDCT11. When using the Hall Sensor Decoder function, the direction can be determined using the FRS bit and the brake can be controlled using the BRKE bit. Both bits are in the HDCR register. Six bits in the HDCT0~HDCT5 registers are used for the Motor Forward table, and six bits in the HDCT6~HDCT11 registers are used for the Motor Backward table.

The accompanying tables show the truth tables for each of the registers.

	60 degree			120 degree			Bit5	Bit4	Bit3	Bit2	Bit1	Bit0
	SA	SB	SC	SA	SB	SC	HAT	HAB	HBT	HBB	HCT	HCB
Forward (HDCEN=1, FRS=0, BRKE=0)	1	0	0	1	0	0	HDCT0[5:0]					
	1	1	0	1	1	0	HDCT1[5:0]					
	1	1	1	0	1	0	HDCT2[5:0]					
	0	1	1	0	1	1	HDCT3[5:0]					
	0	0	1	0	0	1	HDCT4[5:0]					
	0	0	0	1	0	1	HDCT5[5:0]					

Hall Sensor Decoder Forward Truth Table

	60 degree			120 degree			Bit5	Bit4	Bit3	Bit2	Bit1	Bit0
	SA	SB	SC	SA	SB	SC	HAT	HAB	HBT	HBB	HCT	HCB
Backward (HDCEN=1, FRS=1, BRKE=0)	1	0	0	1	0	0	HDCT6[5:0]					
	1	1	0	1	1	0	HDCT7[5:0]					
	1	1	1	0	1	0	HDCT8[5:0]					
	0	1	1	0	1	1	HDCT9[5:0]					
	0	0	1	0	0	1	HDCT10[5:0]					
	0	0	0	1	0	1	HDCT11[5:0]					

Hall Sensor Decoder Backward Truth Table

The truth tables for the brake function, hall decoder disable function and hall decoder error function are also shown below.

Brake (BRKE=1, HDCEN=X, FRS=X)	60 degree			120 degree			Bit5	Bit4	Bit3	Bit2	Bit1	Bit0
	SA	SB	SC	SA	SB	SC	HAT	HAB	HBT	HBB	HCT	HCB
	V	V	V	V	V	V	0	1	0	1	0	1

Brake Truth Table

Hall Decoder disable (HDCEN=0)	60 degree			120 degree			Bit5	Bit4	Bit3	Bit2	Bit1	Bit0
	SA	SB	SC	SA	SB	SC	HAT	HAB	HBT	HBB	HCT	HCB
	V	V	V	V	V	V	0	0	0	0	0	0

Hall Decoder Disable Truth Table

Hall Decoder error (HDCEN=X)	60 degree			120 degree			Bit5	Bit4	Bit3	Bit2	Bit1	Bit0
	SA	SB	SC	SA	SB	SC	HAT	HAB	HBT	HBB	HCT	HCB
	1	0	1	1	1	1	0	0	0	0	0	0
	0	1	0	0	0	0	0	0	0	0	0	0

Hall Decoder Error Truth Table

The relationship between the data in the truth tables and how they relate to actual motor drive signals is shown in the accompanying timing diagram. The full 6 step cycle for both forward and backward motor rotation is provided.

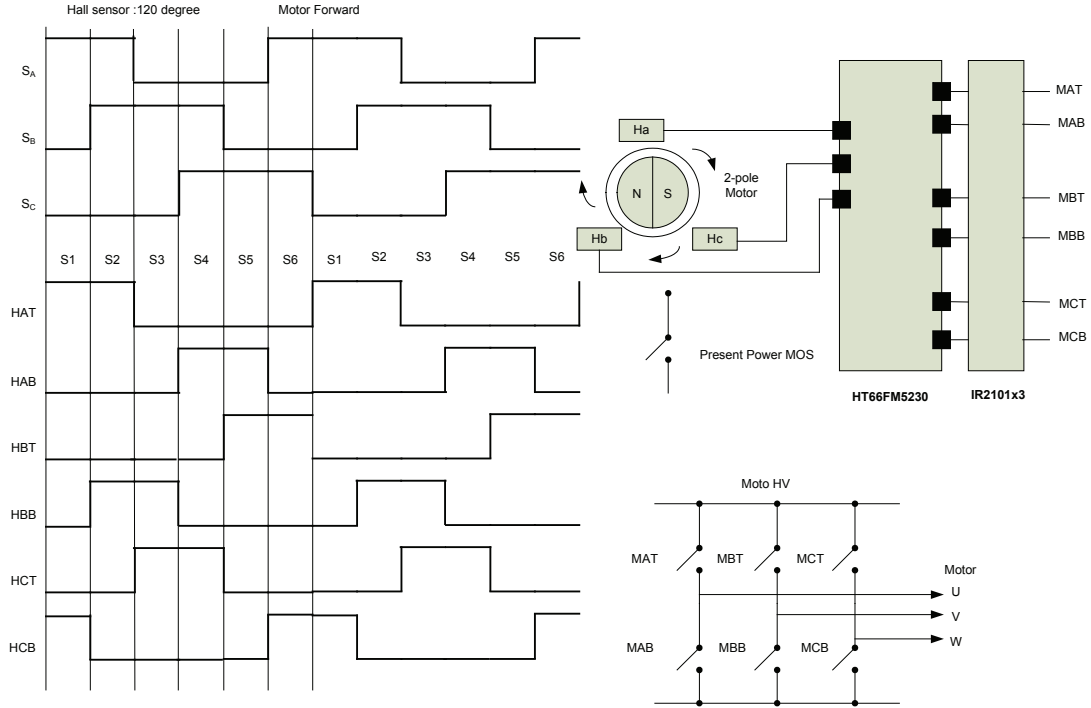

Motor Drive Signal Timing Diagram – Forward Direction

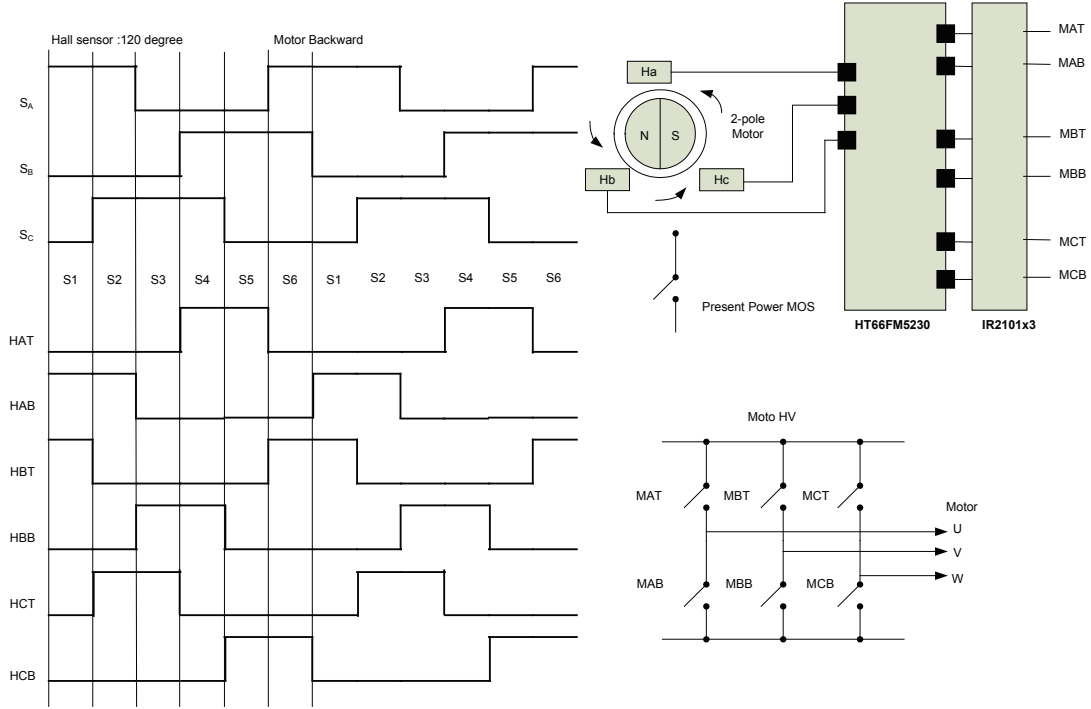

Motor Drive Signal Timing Diagram – Backward Direction

Hall Sensor Decoder Register Description

The HDCR register is the Hall Sensor Decoder control register, HDCD is the Hall Sensor Decoder input data register, and HDCT0~HDCT11 are the Hall Sensor Decoder tables. The HCHK_NUM register is the Hall Noise Filter check number register and HNF_MSEL is the Hall Noise Filter Mode select register.

• INTEG Register

Bit	7	6	5	4	3	2	1	0
Name	—	HSEL	INTCS1	INTCS0	INTBS1	INTBS0	INTAS1	INTAS0
R/W	—	R/W	R/W	R/W	R/W	R/W	R/W	R/W
POR	—	0	0	0	0	0	0	0

- bit 7 Unimplemented, read as "0"
- Bit 6 **HSEL:** HA/HB/HC source select
0: H1/H2/H3
1: CMP1/CMP2/CMP3 output
- bit 5~4 **INTCS1, INTCS0:** FHC Interrupt edge control for INTC
00 : disable
01 : rising edge trigger
10 : falling edge trigger
11 : dual edge trigger
- bit 3~2 **INTBS1, INTBS0:** FHB Interrupt edge control for INTB
00 : disable
01 : rising edge trigger
10 : falling edge trigger
11 : dual edge trigger
- bit 1~0 **INTAS1, INTAS0:** FHA Interrupt edge control for INTA
00 : disable
01 : rising edge trigger
10 : falling edge trigger
11 : dual edge trigger

• HDCR Register

Bit	7	6	5	4	3	2	1	0
Name	CTM_SEL1	CTM_SELO	HDLY_MSEL	HALS	HDMS	BRKE	FRS	HDCEN
R/W	R/W	R/W	R/W	R/W	R/W	R/W	R/W	R/W
POR	0	0	0	1	0	0	0	0

- Bit 7~6 **CTM_SEL1~CTM_SELO:** TM select of the Hall Delay Circuit
00:TM0(10-bit CTM)
01:TM1(16-bit CTM)
10:TM2(10-bit STM)
11:Unused
- Bit 5 **HDLY_MSEL:** Hall Delay Circuit select
0: Select original path
1: Select Hall Delay Circuit
- Bit 4 **HALS:** Hall Sensor Decoder Mode select
0: Hall Sensor 60 degree
1: Hall Sensor 120 degree
- Bit 3 **HDMS:** Hall Sensor Decoder Mode select
0: S/W Mode
1: Hall Sensor Mode
- Bit 2 **BRKE:** motor brake control
0: AT/BT/CT/AB/BB/CB=V
1: AT/BT/CT=0, AB/BB/CB=1

- Bit 1 **FRS:** Motor Forward/Backward select
 0: Forward
 1: Backward
- Bit 0 **HDCEN:** Hall Sensor Decoder enable
 0: Disable
 1: Enable

• **HDCD Register**

Bit	7	6	5	4	3	2	1	0
Name	—	—	—	—	—	SHC	SHB	SHA
R/W	—	—	—	—	—	R/W	R/W	R/W
POR	—	—	—	—	—	0	0	0

Bit 7~3 Unimplemented, read as "0"

- Bit 2 **SHC:** S/W Hall C
- Bit 1 **SHB:** S/W Hall B
- Bit 0 **SHA:** S/W Hall A

• **HDCTn Register n=0~11**

Bit	7	6	5	4	3	2	1	0
Name	—	—	HATDn	HABDn	HBTDn	HBBDn	HCTDn	HCBDn
R/W	—	—	R/W	R/W	R/W	R/W	R/W	R/W
POR	—	—	0	0	0	0	0	0

Bit 7~6 Unimplemented, read as "0"

- Bit 5 **HATDn:** GAT output state control
- Bit 4 **HABDn:** GAB output state control
- Bit 3 **HBTDn:** GBT output state control
- Bit 2 **HBBDn:** GBB output state control
- Bit 1 **HCTDn:** GCT output state control
- Bit 0 **HCBDn:** GCB output state control

Bit value	Status
0	Output is low
1	Output is high

Output Status

• **HCHK_NUM Register**

Bit	7	6	5	4	3	2	1	0
Name	—	—	—	HCK_N4	HCK_N3	HCK_N2	HCK_N1	HCK_N0
R/W	—	—	—	R/W	R/W	R/W	R/W	R/W
POR	—	—	—	0	0	0	0	0

Bit 7~5 Unimplemented, read as "0"

- Bit 4~0 **HCK_N4 ~ HCK_N0:** Hall Noise Filter check number

• **HNF_MSEL Register**

Bit	7	6	5	4	3	2	1	0
Name	—	—	—	—	HNF_EN	HFR_SEL2	HFR_SEL1	HFR_SEL0
R/W	—	—	—	—	R/W	R/W	R/W	R/W
POR	—	—	—	—	0	0	0	0

Bit 7~4 Unimplemented, read as "0"

Bit 3 **HNF_EN**: Hall noise filter enable
0: Disable(bypass)
1: Enable

Bit 2~0 **HFR_SEL2 ~ HFR_SEL0**: Hall noise filter clock source select
000: $f_{SYS}/2$
001: $f_{SYS}/4$
010: $f_{SYS}/8$
011: $f_{SYS}/16$
100: $f_{SYS}/32$
101: $f_{SYS}/64$
110: $f_{SYS}/128$
111: Unused

Motor Protection Function

Motors normally require large currents for their operation and as such need to be protected from the problems of excessive drive currents, motor stalling etc to reduce motor damage or for safety reasons. This device includes a range of protection and safety features.

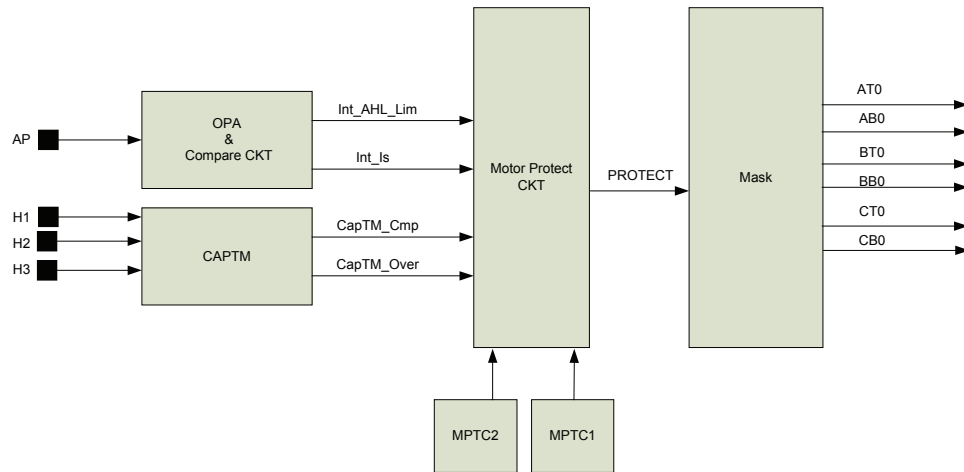

Protection Function Block Diagram

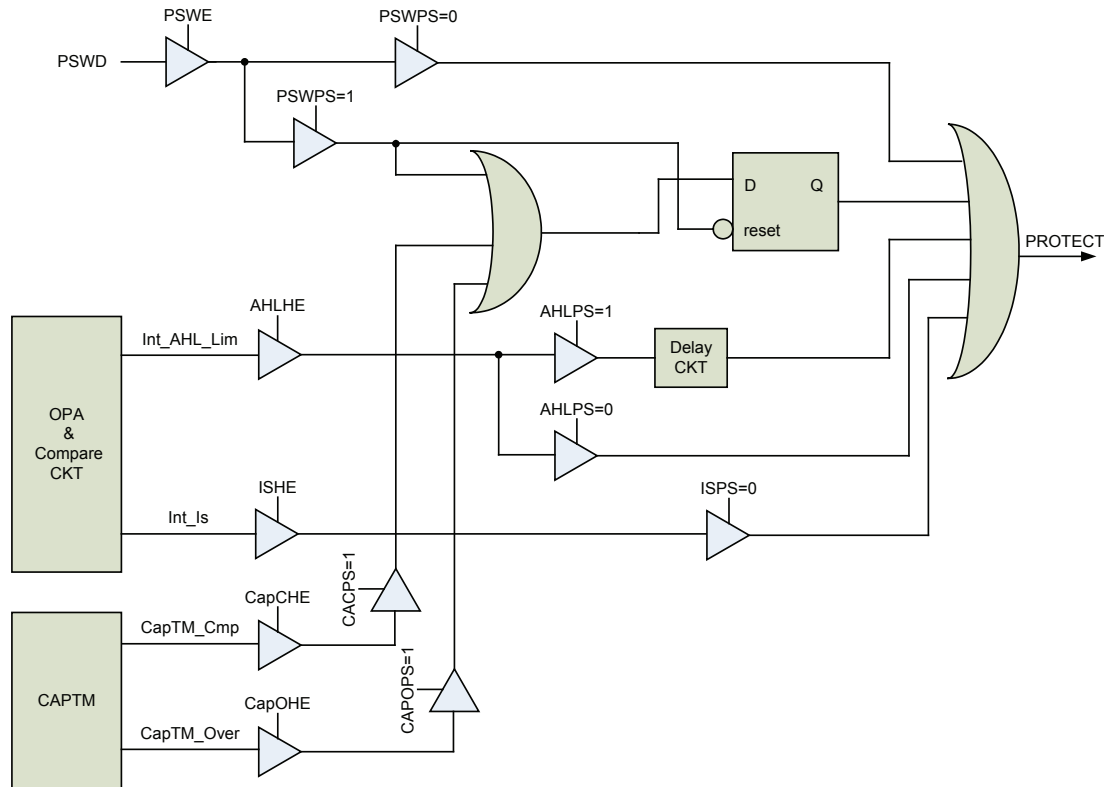

Protection Function Control

Motor Protection Function Description

This device provides three kinds of protection features, allowing action to be taken to protect the motor from damage or to provide additional safety.

The protection features are:

- Stall detection function
- Over current protection
- Turn off the motor using software

When the motor protection circuit is on, the external Gate Drive transistor pair can be put into two different protection modes. The first is the Brake Mode which is where the top arm is off and the bottom arm is on, and the second is the Free Running Mode where both top and bottom arms are off. The FMOS bit in the MCF register determines which type is used.

The motor protection circuit operates in two modes, which is selected by the MPTC2 register. One mode is the Fault Mode and the other is Pause Mode. In the Fault Mode, activating the protect function is determined by the trigger source starting status. Ending the protect function is determined by the trigger source disarming status. In the Pause Mode, turning on the protect function is determined by the trigger source. Ending the protection function is determined by software.

Current Protection Function

The device uses an internal OPA with a gain of 10, a high speed 10-bit A/D Converter, an 8-bit D/A Converter and a comparator to measure the motor current and to detect for excessive current values. If an over current situation should occur, then the external drive circuit must be shut down immediately to prevent motor damage.

As the motor driver PCB will have rather large amounts of noise, and as this noise will be amplified by the OPA, this can easily lead to false triggering. For this reason the fault mode must be used.

For the MOS current limiting mechanism Int_AHL_Li: When AHLHE=0 then the hardware mode is disabled, and when AHLHE=1 the hardware is enabled. The current limiting circuit is a hardware circuit, for which the A/D converter channel must select the operation amplifier if it is to be effective.

AHLPS=0 → The protection circuit will allow the PWM output to immediately restart once the Int_AHL_Lim interrupt has been reset.

AHLPS=1 → The protection circuit will only allow the PWM output to restart on the next PWM period once the Int_AHL_Lim interrupt has been reset.

MOS over-current mechanism Int_Is: when ISHE=0 the hardware mode is disabled and when ISHE=1 the hardware mode is enabled. ISPS=0 then select the Fault Mode

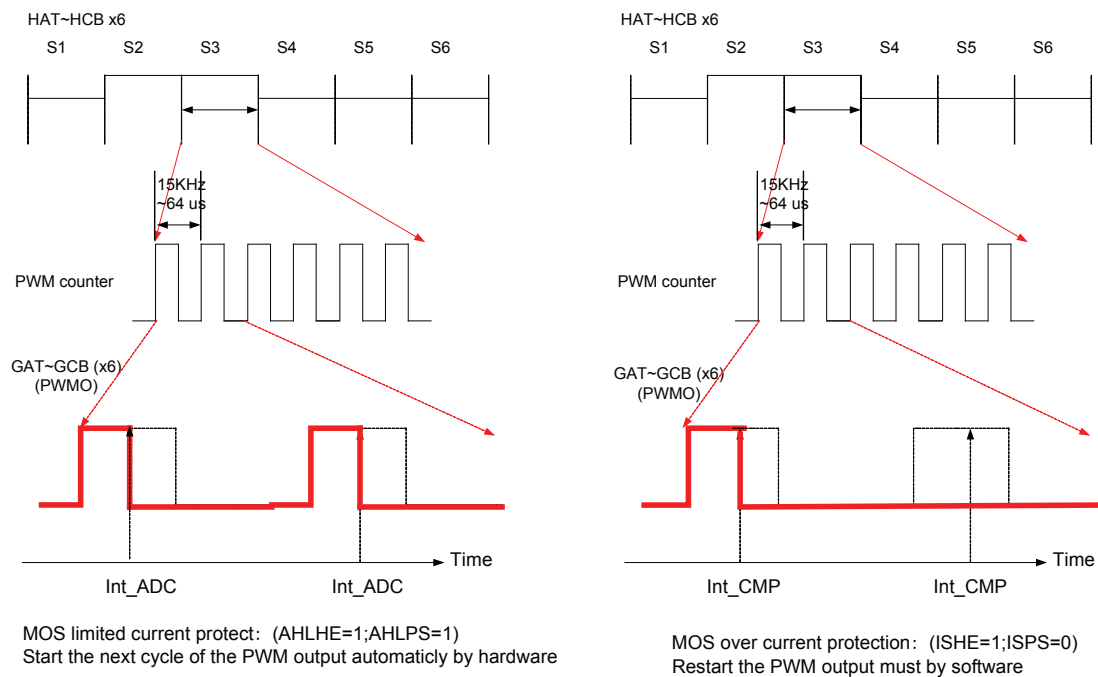

Over Current

Motor Stall Detection Function

For 3-phase BLDC applications with Hall Sensors, the 16-bit CAPTM can be used to monitor INT0A, INT0B and INT0C for rotor speed detection. The software will setup the CAPTMAH and CAPTMAL registers to monitor the Hall sensor inputs INT0A, INT0B and INT0C for motor speed control. If an abnormal situation exists, then a CapTM_Cmp or CapTM_Over interrupt will be generated.

Stall Detect Mechanism CapTM_Cmp: when CapCHE=0 disable the hardware mode and when CapCHE=1 enable the hardware mode. The stall detect mechanism must use the Pause Mode.

CAPCPS=1, then select the Pause Mode.

Stall Detect Mechanism CapTM_Over: when CapOHE=0 disable the hardware mode and when CapOHE=1, enable the hardware mode.

CAPOPS=1, then select the Pause Mode.

Motor Protection Circuit Register Description

There are two registers, MPTC1 and MPTC2, which are used for the motor protection control function.

• MPTC1 Register

Bit	7	6	5	4	3	2	1	0
Name	PSWD	PSWE	CapOHE	CapCHE	ISHE	AHLHE	—	—
R/W	R/W	R/W	R/W	R/W	R/W	R/W	—	—
POR	0	0	0	0	0	0	—	—

Bit 7 **PSWD:** Protect S/W Mode data
 0: PSWD=0
 1: PSWD=1

Bit 6 **PSWE:** Protect S/W Mode enable
 0: Disable
 1: Enable

Bit 5 **CapOHE:** CapTM_Over H/W Mode enable
 0: Disable
 1: Enable

Bit 4 **CapCHE:** CapTM_Cmp H/W Mode enable
 0: Disable
 1: Enable

Bit 3 **ISHE:** Int_Is H/W Mode enable
 0: Disable
 1: Enable

Bit 2 **AHLHE:** Int_AHL_Lim H/W Mode enable
 0: Disable
 1: Enable

Bit 1~0 Unimplemented, read as "0"

• **MPTC2 Register**

Bit	7	6	5	4	3	2	1	0
Name	—	—	—	PSWPS	AHLPS	ISPS	CAPCPS	CAPOPS
R/W	—	—	—	R/W	R/W	R/W	R/W	R/W
POR	—	—	—	1	0	0	1	1

Bit 7~5 Unimplemented, read as "0"

Bit 4 **PSWPS:** Pause/Fault Mode select

0: Select Fault Mode

1: Select Pause Mode

Bit 3 **AHLPS:** Int_AHL_Lim Pause/Fault Mode Selection

0: Protection circuit allows immediate restart of PWM output when the Int_AHL_Lim interrupt has been reset.

1: Protection circuit only allows restart of PWM output when on the next PWM period when the Int_AHL_Lim interrupt has been reset.

Bit 2 **ISPS:** Int_Is Pause/Fault Mode select

0: undefined, cannot be selected

1: Select Pause Mode

Bit 1 **CAPCPS:** CapTM_Cmp Pause/Fault Mode select

0: Select Fault Mode

1: Select Pause Mode

Bit 0 **CAPOPS:** CapTM_Over Pause Mode select

0: undefined, cannot be selected

1: Select Pause Mode

I²C Interface

The I²C interface is used to communicate with external peripheral devices such as sensors, EEPROM memory etc. Originally developed by Philips, it is a two line low speed serial interface for synchronous serial data transfer. The advantage of only two lines for communication, relatively simple communication protocol and the ability to accommodate multiple devices on the same bus has made it an extremely popular interface type for many applications.

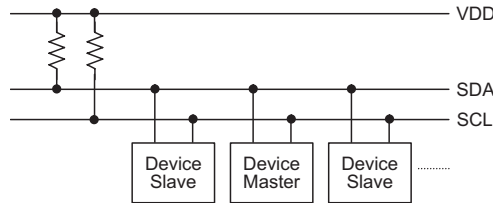

I²C Master/Slave Bus Connection

I²C Interface Operation

The I²C serial interface is a two line interface, a serial data line, SDA, and serial clock line, SCL. As many devices may be connected together on the same bus, their outputs are both open drain types. For this reason it is necessary that external pull-high resistors are connected to these outputs. Note that no chip select line exists, as each device on the I²C bus is identified by a unique address which will be transmitted and received on the I²C bus.

When two devices communicate with each other on the bidirectional I²C bus, one is known as the master device and one as the slave device. Both master and slave can transmit and receive data, however, it is the master device that has overall control of the bus. For this device, which only operates in slave mode, there are two methods of transferring data on the I²C bus, the slave transmit mode and the slave receive mode.

It is suggested that the user shall not enter the micro processor to HALT mode by application program during processing I²C communication.

If the pin is configured to SDA or SCL function of I²C interface, the pin is configured to open-collect Input/Output port and its pull-up function can be enabled by programming the related Generic Pull-up Control Register.

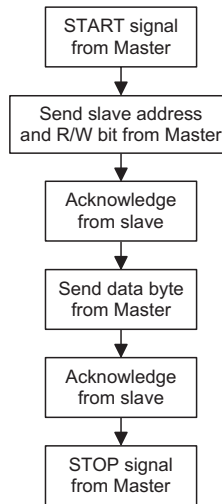

I²C Registers

There are four control registers associated with the I²C bus, IICC0, IICC1, IICA and I2CTOC and one data register, IICD. The IICD register, is used to store the data being transmitted and received on the I²C bus. Before the microcontroller writes data to the I²C bus, the actual data to be transmitted must be placed in the IICD register. After the data is received from the I²C bus, the microcontroller can read it from the IICD register. Any transmission or reception of data from the I²C bus must be made via the IICD register.

Register Name	Bit							
	7	6	5	4	3	2	1	0
IICC0	—	—	—	—	I2CDBNC1	I2CDBNC0	I2CEN	—
IICC1	IICHCF	IICHAAS	IICHBB	IICHTX	IICTXAK	IICSRW	IICRNIC	IICRXAK
IICD	IICDD7	IICDD6	IICDD5	IICDD4	IICDD3	IICDD2	IICDD1	IICDD0
IICA	IICA6	IICA5	IICA4	IICA3	IICA2	IICA1	IICA0	—
I2CTOC	I2CTOEN	I2CTOF	I2CTOS5	I2CTOS4	I2CTOS3	I2CTOS2	I2CTOS1	I2CTOS0

I²C Registers List

IICC0 Register

Bit	7	6	5	4	3	2	1	0
Name	—	—	—	—	I2CDBNC1	I2CDBNC0	I2CEN	—
R/W	—	—	—	—	R/W	R/W	R/W	—
POR	—	—	—	—	0	0	0	—

- Bit 7~4 unimplemented, read as "0"
- Bit 3~2 **I2CDBNC1~I2CDBNC0**: I²C Debounce Time Selection
 - 00: No debounce
 - 01: 2 system clock debounce
 - 10: 4 system clock debounce
 - 11: 4 system clock debounce
- Bit 1 **I2CEN**: I²C enable
 - 0: Disable
 - 1: Enable
- Bit 0 Unimplemented, read as "0"

SPI function could be turned off or turned on by controlling the related pin-sharing control bit which decides the function of the IO ports pin-shared the pins SDA and SCL. When the IO ports pin-shared the pins SDA and SCL are chosen to the functions other than SDA and SCL by pin-sharing control bit, SPI function is turned off and its operating current will be reduced to a minimum value. In contrary, SPI function is turned on when the IO ports pin-shared the pins SDA and SCL are chosen to the pins SDA and SCL by controlling pin-sharing control bit.

IICC1 Register

Bit	7	6	5	4	3	2	1	0
Name	IICHCF	IICHAAS	IICHBB	IICHTX	IICTXAK	IICSRW	IICRNIC	IICRXAK
R/W	R	R	R	R/W	R/W	R	R/W	R
POR	1	0	0	0	0	0	0	1

- Bit 7 IICHCF:** I²C Bus data transfer completion flag
 0: Data is being transferred
 1: Completion of an 8-bit data transfer
 The IICHCF flag is the data transfer flag. This flag will be zero when data is being transferred. Upon completion of an 8-bit data transfer the flag will go high and an interrupt will be generated.
 Below is an example of the flow of a two-byte IIC data transfer.
 First, IIC slave device receive a start signal from IIC master and then IICHCF bit is automatically cleared to zero.
 Second, IIC slave device finish receiving the 1st data byte and then IICHCF bit is automatically set to one.
 Third, user read the 1st data byte from IICD register by the application program and then IICHCF bit is automatically cleared to zero.
 Fourth, IIC slave device finish receiving the 2nd data byte and then IICHCF bit is automatically set to one and so on.
 Finally, IIC slave device receive a stop signal from IIC master and then IICHCF bit is automatically set to one.
- Bit 6 IICHAAS:** I²C Bus address match flag
 0: Not address match
 1: Address match
 The IICHASS flag is the address match flag. This flag is used to determine if the slave device address is the same as the master transmit address. If the addresses match then this bit will be high, if there is no match then the flag will be low.
- Bit 5 IICHBB:** I²C Bus busy flag
 0: I²C Bus is not busy
 1: I²C Bus is busy
 The IICHBB flag is the I²C busy flag. This flag will be "1" when the I²C bus is busy which will occur when a START signal is detected. The flag will be set to "0" when the bus is free which will occur when a STOP signal is detected.
- Bit 4 IICHTX:** Select I²C slave device is transmitter or receiver
 0: Slave device is the receiver
 1: Slave device is the transmitter
- Bit 3 IICTXAK:** I²C Bus transmit acknowledge flag
 0: Slave send acknowledge flag
 1: Slave do not send acknowledge flag
 The IICTXAK bit is the transmit acknowledge flag. After the slave device receipt of 8-bits of data, this bit will be transmitted to the bus on the 9th clock from the slave device. The slave device must always set IICTXAK bit to "0" before further data is received.
- Bit 2 IICSRW:** I²C Slave Read/Write flag
 0: Slave device should be in receive mode
 1: Slave device should be in transmit mode
 The IICSRW flag is the I²C Slave Read/Write flag. This flag determines whether the master device wishes to transmit or receive data from the I²C bus. When the transmitted address and slave address is match, that is when the IICHAAS flag is set high, the slave device will check the IICSRW flag to determine whether it should be in transmit mode or receive mode. If the IICSRW flag is high, the master is requesting to read data from the bus, so the slave device should be in transmit mode. When the IICSRW flag is zero, the master will write data to the bus, therefore the slave device should be in receive mode to read this data.

Bit 1 IICRNIC: I²C running using Internal Clock Control
 0: I²C running using internal clock
 1: I²C running not using Internal Clock
 The I²C module can run without using internal clock, and generate an interrupt if the IIC interrupt is enabled, which can be used in SLEEP Mode, IDLE(SLOW) Mode, NORMAL(SLOW) Mode.

Bit 0 IICRXAK: I²C Bus Receive acknowledge flag
 0: Slave receive acknowledge flag
 1: Slave do not receive acknowledge flag
 The IICRXAK flag is the receiver acknowledge flag. When the IICRXAK flag is "0", it means that a acknowledge signal has been received at the 9th clock, after 8 bits of data have been transmitted. When the slave device in the transmit mode, the slave device checks the IICRXAK flag to determine if the master receiver wishes to receive the next byte. The slave transmitter will therefore continue sending out data until the IICRXAK flag is "1". When this occurs, the slave transmitter will release the SDA line to allow the master to send a STOP signal to release the I²C Bus.

The IICD register is used to store the data being transmitted and received. The same register is used by both the SPI and I²C functions. Before the device writes data to the I²C bus, the actual data to be transmitted must be placed in the IICD register. After the data is received from the I²C bus, the device can read it from the IICD register. Any transmission or reception of data from the I²C bus must be made via the IICD register.

IICD Register

Bit	7	6	5	4	3	2	1	0
Name	IICDD7	IICDD6	IICDD5	IICDD4	IICDD3	IICDD2	IICDD1	IICDD0
R/W	R/W	R/W	R/W	R/W	R/W	R/W	R/W	R/W
POR	x	x	x	x	x	x	x	x

"x" unknown

Bit 7~0 IICDD7~IICDD0: IIC Data Buffer bit 7~bit 0

IICA Register

Bit	7	6	5	4	3	2	1	0
Name	IICA6	IICA5	IICA4	IICA3	IICA2	IICA1	IICA0	—
R/W	R/W	R/W	R/W	R/W	R/W	R/W	R/W	—
POR	x	x	x	x	x	x	x	—

"x" unknown

Bit 7~1 IICA6~IICA0: I²C slave address
 IICA6~ IICA0 is the I²C slave address bit 6 ~ bit 0.
 The IICA register is the location where the 7-bit slave address of the slave device is stored. Bits 7~ 1 of the IICA register define the device slave address. Bit 0 is not defined.

When a master device, which is connected to the I²C bus, sends out an address, which matches the slave address in the IICA register, the slave device will be selected.

Bit 0 Unimplemented, read as "0"

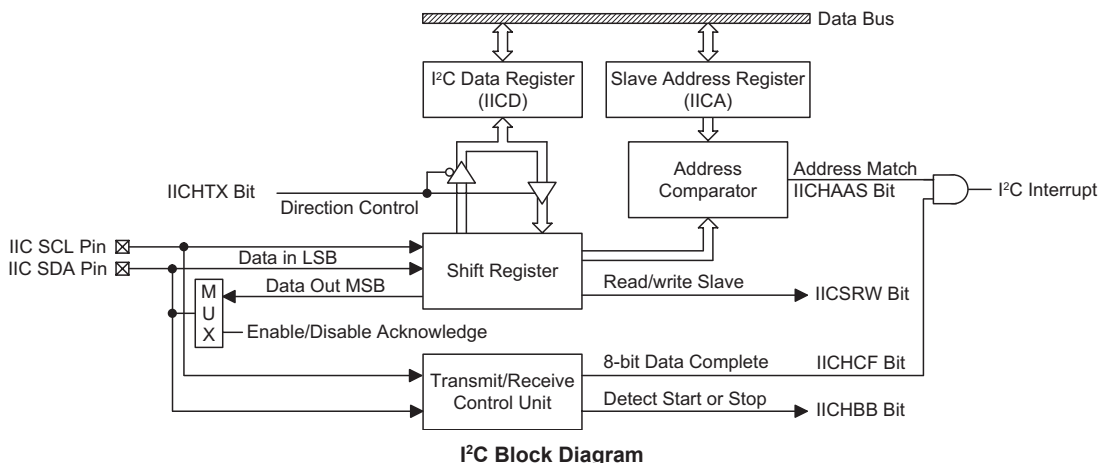

I²C Bus Communication

Communication on the I²C bus requires four separate steps, a START signal, a slave device address transmission, a data transmission and finally a STOP signal. When a START signal is placed on the I²C bus, all devices on the bus will receive this signal and be notified of the imminent arrival of data on the bus. The first seven bits of the data will be the slave address with the first bit being the MSB. If the address of the slave device matches that of the transmitted address, the IICHAAS bit in the IICC1 register will be set and an I²C interrupt will be generated. After entering the interrupt service routine, the slave device must first check the condition of the IICHAAS bit to determine whether the interrupt source originates from an address match or from the completion of an 8-bit data transfer. During a data transfer, note that after the 7-bit slave address has been transmitted, the following bit, which is the 8th bit, is the read/write bit whose value will be placed in the SRW bit. This bit will be checked by the slave device to determine whether to go into transmit or receive mode. Before any transfer of data to or from the I²C bus, the microcontroller must initialise the bus, the following are steps to achieve this:

- Step 1
Set Configure the pin-shared I/O ports to I²C pin function. (SCL and SAD).
- Step 2
Set I2CEN bit in the IICC0 register to "1" to enable the I²C bus.
- Step 3
Write the slave address of the device to the I²C bus address register IICA.
- Step 4
Set the IICE interrupt enable bit of the interrupt control register to enable the I²C interrupt and Multi-function interrupt.

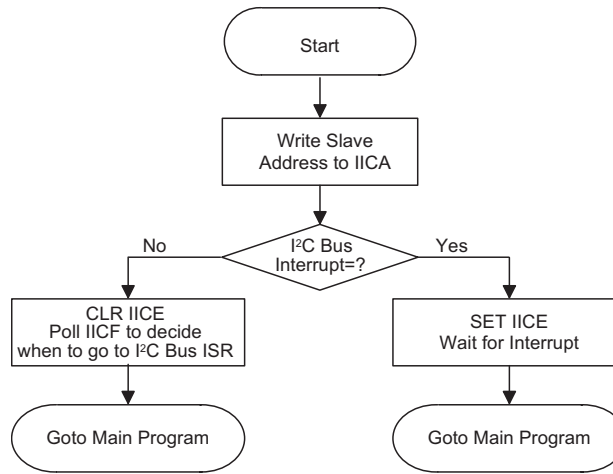

I²C Bus Initialisation Flow Chart

I²C Bus Start Signal

The START signal can only be generated by the master device connected to the I²C bus and not by the slave device. This START signal will be detected by all devices connected to the I²C bus. When detected, this indicates that the I²C bus is busy and therefore the IICHBB bit will be set. A START condition occurs when a high to low transition on the SDA line takes place when the SCL line remains high.

Slave Address

The transmission of a START signal by the master will be detected by all devices on the I²C bus. To determine which slave device the master wishes to communicate with, the address of the slave device will be sent out immediately following the START signal. All slave devices, after receiving this 7-bit address data, will compare it with their own 7-bit slave address. If the address sent out by the master matches the internal address of the microcontroller slave device, then an internal I²C bus interrupt signal will be generated. The next bit following the address, which is the 8th bit, defines the read/write status and will be saved to the IICSRW bit of the IICC1 register. The slave device will then transmit an acknowledge bit, which is a low level, as the 9th bit. The slave device will also set the status flag IICHAAS when the addresses match.

As an I²C bus interrupt can come from two sources, when the program enters the interrupt subroutine, the IICHAAS bit should be examined to see whether the interrupt source has come from a matching slave address or from the completion of a data byte transfer. When a slave address is matched, the device must be placed in either the transmit mode and then write data to the IICD register, or in the receive mode where it must implement a dummy read from the IICD register to release the SCL line.

I²C Bus Read/Write Signal

The IICSRW bit in the IICC1 register defines whether the slave device wishes to read data from the I²C bus or write data to the I²C bus. The slave device should examine this bit to determine if it is to be a transmitter or a receiver. If the IICSRW flag is "1" then this indicates that the master device wishes to read data from the I²C bus, therefore the slave device must be setup to send data to the I²C bus as a transmitter. If the IICSRW flag is "0" then this indicates that the master wishes to send data to the I²C bus, therefore the slave device must be setup to read data from the I²C bus as a receiver.

I²C Bus Slave Address Acknowledge Signal

After the master has transmitted a calling address, any slave device on the I²C bus, whose own internal address matches the calling address, must generate an acknowledge signal. The acknowledge signal will inform the master that a slave device has accepted its calling address. If no acknowledge signal is received by the master then a STOP signal must be transmitted by the master to end the communication. When the IICHAAS flag is high, the addresses have matched and the slave device must check the IICSRW flag to determine if it is to be a transmitter or a receiver. If the IICSRW flag is high, the slave device should be setup to be a transmitter so the IICHTX bit in the IICC1 register should be set to "1". If the IICSRW flag is low, then the microcontroller slave device should be setup as a receiver and the IICHTX bit in the IICC1 register should be set to "0".

I²C Bus Data and Acknowledge Signal

The transmitted data is 8-bits wide and is transmitted after the slave device has acknowledged receipt of its slave address. The order of serial bit transmission is the MSB first and the LSB last. After receipt of 8-bits of data, the receiver must transmit an acknowledge signal, level "0", before it can receive the next data byte. If the slave transmitter does not receive an acknowledge bit signal from the master receiver, then the slave transmitter will release the SDA line to allow the master to send a STOP signal to release the I²C Bus. The corresponding data will be stored in the IICD register. If setup as a transmitter, the slave device must first write the data to be transmitted into the IICD register. If setup as a receiver, the slave device must read the transmitted data from the IICD register.

When the slave receiver receives the data byte, it must generate an acknowledge bit, known as IICTXAK, on the 9th clock. The slave device, which is setup as a transmitter will check the IICRXAK bit in the IICC1 register to determine if it is to send another data byte, if not then it will release the SDA line and await the receipt of a STOP signal from the master.

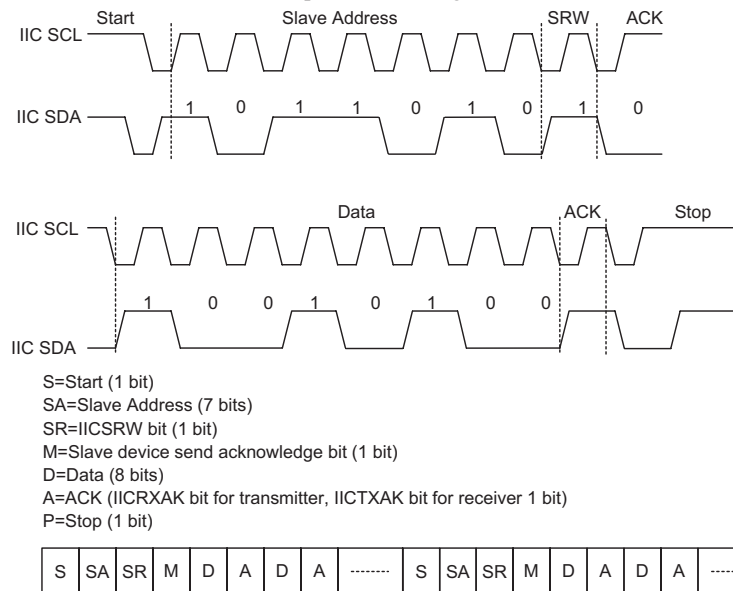

I²C Communication Timing Diagram

Note: *When a slave address is matched, the device must be placed in either the transmit mode and then write data to the IICD register, or in the receive mode where it must implement a dummy read from the IICD register to release the I²C SCL line.

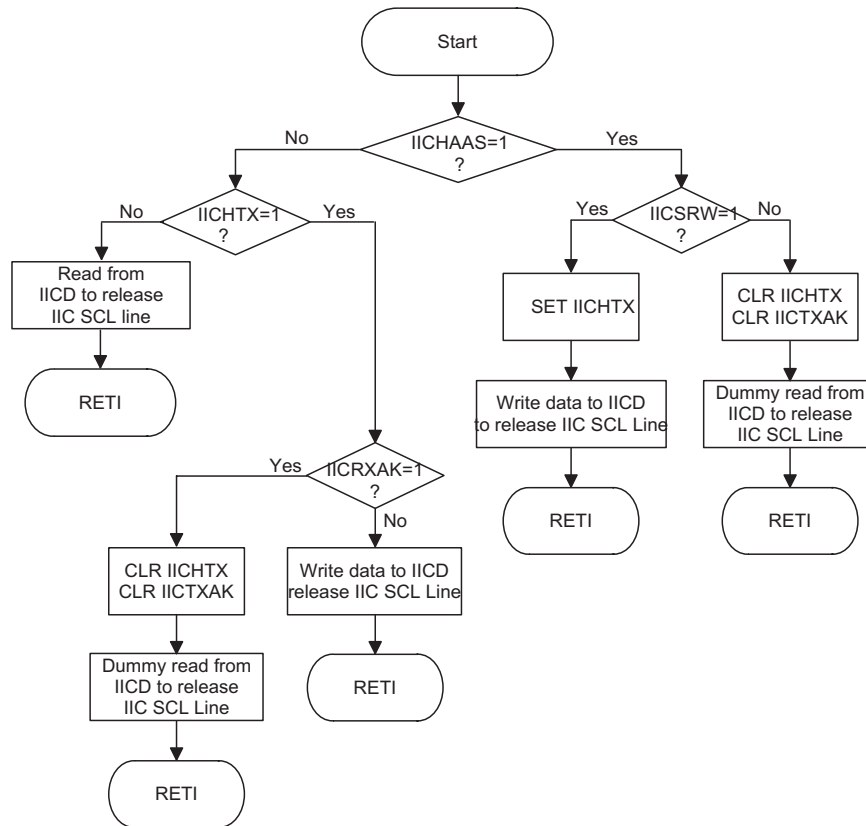

I²C Bus ISR Flow Chart

I²C Time-out Control

In order to reduce the problem of I²C lockup due to reception of erroneous clock sources, a time-out function is provided. If the clock source to the I²C is not received then after a fixed time period, the I²C circuitry and registers will be reset.

The time-out counter starts counting on an I²C bus "START" & "address match" condition, and is cleared by an SCL falling edge. Before the next SCL falling edge arrives, if the time elapsed is greater than the time-out setup by the I2CTOC register, then a time-out condition will occur. The time-out function will stop when an I²C "STOP" condition occurs.

When an I²C time-out counter overflow occurs, the counter will stop and the I2CTOEN bit will be cleared to zero and the I2CTOF bit will be set high to indicate that a time-out condition has occurred. The time-out condition will also generate an interrupt which uses the I²C interrupt vector. When an I²C time-out occurs, the I²C internal circuitry will be reset and the registers will be reset into the following condition:

Register	After I ² C Time-out
IICD, IICA, IICC0	No change
IICC1	Reset to POR condition

I²C Registers After Time-out

The I2CTOF flag can be cleared by the application program. There are 64 time-out periods which can be selected using bits in the I2CTOC register. The time-out time is given by the formula:

$$((1 \sim 64) \times 32) / f_{\text{SUB}}$$

This gives a range of about 1ms to 64ms. Note also that the LIRC oscillator is continuously enabled.

I2CTOC Register

Bit	7	6	5	4	3	2	1	0
Name	I2CTOEN	I2CTOF	I2CTOS5	I2CTOS4	I2CTOS3	I2CTOS2	I2CTOS1	I2CTOS0
R/W	R/W	R/W	R/W	R/W	R/W	R/W	R/W	R/W
POR	0	0	0	0	0	0	0	0

Bit 7 **I2CTOEN:** I²C Time-out Control
 0: disable
 1: enable

Bit 6 **I2CTOF:** Time-out flag (set by time-out and clear by software)
 0: no time-out
 1: time-out occurred

Bit 5~0 **I2CTOS5~I2CTOS0:** Time-out Definition
 I²C time-out clock source is $f_{\text{SUB}}/32$.
 I²C time-out time is given by: $([I2CTOS5 : I2CTOS0]+1) \times (32/f_{\text{SUB}})$

Interrupts

Interrupts are an important part of any microcontroller system. When an external event or an internal function such as a Timer Module or an A/D converter requires microcontroller attention, their corresponding interrupt will enforce a temporary suspension of the main program allowing the microcontroller to direct attention to their respective needs. The device contains several external interrupt and internal interrupts functions. The external interrupt is generated by the action of the external H1, H2, H3 and NFIN pins, while the internal interrupts are generated by various internal functions such as the TMs, Comparators, 16-bit CAPTM Modul, Time Base, LVD, EEPROM and the A/D converter.

Interrupt Registers

Overall interrupt control, which basically means the setting of request flags when certain microcontroller conditions occur and the setting of interrupt enable bits by the application program, is controlled by a series of registers, located in the Special Purpose Data Memory, as shown in the accompanying table. The number of registers depends upon the device chosen but fall into three categories. The first is the INTC0~INTC2 registers which setup the primary interrupts, the second is the MFI0~MFI4 registers which setup the Multi-function interrupts. Finally there is an INTEG register to setup the external interrupt trigger edge type.

Each register contains a number of enable bits to enable or disable individual registers as well as interrupt flags to indicate the presence of an interrupt request. The naming convention of these follows a specific pattern. First is listed an abbreviated interrupt type, then the (optional) number of that interrupt followed by either an "E" for enable/disable bit or "F" for request flag.

Function	Enable Bit	Request Flag	Notes
Global	EMI	—	—
External interrupt 0 (Hall Sensor HA/HB/HC interrupt)	HALLE	HALLF	MF10
	HALAE	HALAF	Hall Noise Filtered
	HALBE	HALBF	Hall Noise Filtered
	HALCE	HALCF	Hall Noise Filtered
External interrupt 1 (Noise Filter Interrupt)	INT1E	INT1F	NFIN Interrupt Noise Filtered
Comparator 0	C0E	C0F	—
Time Base	TBE	TBF	—
A/D Converter	AEOCE	AEOCF	—
	ALIME	ALIMF	—
CAPTM	CAPOE	CAPOF	—
	CAPCE	CAPCF	—
LVD	LVDE	LVDF	—
EEPROM write	EPWE	EPWF	—
PWM	PWMDnE	PWMDnF	n=0,1,2
	PWMPE	PWMPF	—
CTM	TMnAE	TMnAF	n=0,1
	TMnPE	TMnPF	n=0,1
STM	TMnAE	TMnAF	n=2
	TMnPE	TMnPF	n=2
I ² C	IICE	IICF	—
Multifunction interrupt	MFnE	MFnF	n=0~4

Interrupt Register Bit Naming Conventions

Interrupt Register Contents

Name	Bit7	Bit6	Bit5	Bit4	Bit3	Bit2	Bit1	Bit0
INTEG	—	HSEL	INTCS1	INTCS0	INTBS1	INTBS0	INTAS1	INTAS0
INTC0	—	C0F	INT1F	HALLF	C0E	INT1E	HALLE	EMI
INTC1	EPWF	LVDF	MF1F	TBF	EPWE	LVDE	MF1E	TBE
INTC2	IICF	MF4F	MF3F	MF2F	IICE	MF4E	MF3E	MF2E
MF10	—	HALCF	HALBF	HALAF	—	HALCE	HALBE	HALAE
MF11	CAPCF	CAPOF	ALIMF	AEOCF	CAPCE	CAPOE	ALIME	AEOCE
MF12	PWMPF	PWMD2F	PWMD1F	PWMD0F	PWMPE	PWMD2E	PWMD1E	PWMD0E
MF13	TM1AF	TM1PF	TM0AF	TM0PF	TM1AE	TM1PE	TM0AE	TM0PE
MF14	—	—	TM2AF	TM2PF	—	—	TM2AE	TM2PE

INTEG Register

Bit	7	6	5	4	3	2	1	0
Name	—	HSEL	INTCS1	INTCS0	INTBS1	INTBS0	INTAS1	INTAS0
R/W	—	R/W	R/W	R/W	R/W	R/W	R/W	R/W
POR	—	0	0	0	0	0	0	0

- bit 7 Unimplemented, read as "0"
- Bit 6 **HSEL**: HA/HB/HC source select
 0: H1/H2/H3
 1: CMP1/CMP2/CMP3 output
- bit 5~4 **INTCS1, INTCS0**: FHC Interrupt edge control for INTC
 00 : disable
 01 : rising edge trigger
 10 : falling edge trigger
 11 : dual edge trigger
- bit 3~2 **INTBS1, INTBS0**: FHB Interrupt edge control for INTB
 00 : disable
 01 : rising edge trigger
 10 : falling edge trigger
 11 : dual edge trigger
- bit 1~0 **INTAS1, INTAS0**: FHA Interrupt edge control for INTA
 00 : disable
 01 : rising edge trigger
 10 : falling edge trigger
 11 : dual edge trigger

INTC0 Register

Bit	7	6	5	4	3	2	1	0
Name	—	C0F	INT1F	HALLF	C0E	INT1E	HALLE	EMI
R/W	—	R/W	R/W	R/W	R/W	R/W	R/W	R/W
POR	—	0	0	0	0	0	0	0

- Bit 7 Unimplemented, read as "0"
- Bit 6 **C0F**: Comparator 0 interrupt request flag
 0: No request
 1: Interrupt request
- Bit 5 **INT1F**: External 1 interrupt request flag
 0: No request
 1: Interrupt request
- Bit 4 **HALLF**: Hall sensor global interrupt request flag
 0: No request
 1: Interrupt request
- Bit 3 **C0E**: Comparator 0 interrupt control
 0: Disable
 1: Enable
- Bit 2 **INT1E**: External 1 interrupt control
 0: Disable
 1: Enable
- Bit 1 **HALLE**: Hall sensor global interrupt control
 0: Disable
 1: Enable
- Bit 0 **EMI**: Global Interrupt Control
 0: Disable
 1: Enable

INTC1 Register

Bit	7	6	5	4	3	2	1	0
Name	EPWF	LVDF	MF1F	TBF	EPWE	LVDE	MF1E	TBE
R/W	R/W	R/W	R/W	R/W	R/W	R/W	R/W	R/W
POR	0	0	0	0	0	0	0	0

- Bit 7 **EPWF** : Data EEPROM interrupt request flag
0: No request
1: Interrupt request
- Bit 6 **LVDF**: LVD interrupt request flag
0: No request
1: Interrupt request
- Bit 5 **MF1F**: Multi-function Interrupt 1 Request Flag
0: No request
1: Interrupt request
- Bit 4 **TBF**: Time Base interrupt request flag
0: No request
1: Interrupt request
- Bit 3 **EPWE** : Data EEPROM interrupt control
0: Disable
1: Enable
- Bit 2 **LVDE**: LVD interrupt control
0: Disable
1: Enable
- Bit 1 **MF1E**: Multi-function Interrupt 1 Control
0: Disable
1: Enable
- Bit 0 **TBE**: Time Base interrupt control
0: Disable
1: Enable

INTC2 Register

Bit	7	6	5	4	3	2	1	0
Name	IICF	MF4F	MF3F	MF2F	IICE	MF4E	MF3E	MF2E
R/W	R/W	R/W	R/W	R/W	R/W	R/W	R/W	R/W
POR	0	0	0	0	0	0	0	0

- Bit 7 **IICF**: I²C Interrupt Request Flag
0: No request
1: Interrupt request
- Bit 6 **MF4F**: Multi-function interrupt 4 request flag
0: No request
1: Interrupt request
- Bit 5 **MF3F**: Multi-function interrupt 3 request flag
0: No request
1: Interrupt request
- Bit 4 **MF2F**: Multi-function interrupt 2 request flag
0: No request
1: Interrupt request
- Bit 3 **IICE**: I²C interrupt control
0: Disable
1: Enable
- Bit 2 **MF4E**: Multi-function interrupt 4 control
0: Disable
1: Enable
- Bit 1 **MF3E**: Multi-function interrupt 3 control
0: Disable
1: Enable
- Bit 0 **MF2E**: Multi-function interrupt 2 control
0: Disable
1: Enable

MF10 Register

Bit	7	6	5	4	3	2	1	0
Name	—	HALCF	HALBF	HALAF	—	HALCE	HALBE	HALAE
R/W	—	R/W	R/W	R/W	—	R/W	R/W	R/W
POR	—	0	0	0	—	0	0	0

- Bit 7 Unimplemented, read as "0"
- Bit 6 **HALCF**: Hall Sensor C interrupt request flag
 0: No request
 1: Interrupt request
- Bit 5 **HALBF**: Hall Sensor B interrupt request flag
 0: No request
 1: Interrupt request
- Bit 4 **HALAF**: Hall Sensor A interrupt request flag
 0: No request
 1: Interrupt request
- Bit 3 Unimplemented, read as "0"
- Bit 2 **HALCE**: Hall Sensor C interrupt control
 0: Disable
 1: Enable
- Bit 1 **HALBE**: Hall Sensor B interrupt control
 0: Disable
 1: Enable
- Bit 0 **HALAE**: Hall Sensor A interrupt control
 0: Disable
 1: Enable

MF11 Register

Bit	7	6	5	4	3	2	1	0
Name	CAPCF	CAPOF	ALIMF	AEOCF	CAPCE	CAPOE	ALIME	AEOCE
R/W	R/W	R/W	R/W	R/W	R/W	R/W	R/W	R/W
POR	0	0	0	0	0	0	0	0

- Bit 7 **CAPCF**: CAPTM compare match interrupt request flag
 0: No request
 1: Interrupt request
- Bit 6 **CAPOF**: CAPTM capture overflow interrupt request flag
 0: No request
 1: Interrupt request
- Bit 5 **ALIMF**: A/D Converter EOC compare interrupt request flag
 0: No request
 1: Interrupt request
- Bit 4 **AEOCF**: A/D Converter interrupt request flag
 0: No request
 1: Interrupt request
- Bit 3 **CAPCE**: CAPTM compare match interrupt control
 0: Disable
 1: Enable
- Bit 2 **CAPOE**: CAPTM capture overflow interrupt control
 0: Disable
 1: Enable
- Bit 1 **ALIME**: A/D Converter EOC compare interrupt control
 0: Disable
 1: Enable
- Bit 0 **AEOCE**: A/D Converter interrupt control
 0: Disable
 1: Enable

MFI2 Register

Bit	7	6	5	4	3	2	1	0
Name	PWMPF	PWMD2F	PWMD1F	PWMD0F	PWMPE	PWMD2E	PWMD1E	PWMD0E
R/W	R/W	R/W	R/W	R/W	R/W	R/W	R/W	R/W
POR	0	0	0	0	0	0	0	0

- Bit 7 **PWMPF:** PWM Period match interrupt request flag
0: No request
1: Interrupt request
- Bit 6 **PWMD2F:** PWM2 Duty match interrupt request flag
0: No request
1: Interrupt request
- Bit 5 **PWMD1F:** PWM1 Duty match interrupt request flag
0: No request
1: Interrupt request
- Bit 4 **PWMD0F:** PWM0 Duty match interrupt request flag
0: No request
1: Interrupt request
- Bit 3 **PWMPE:** PWM Period match interrupt Interrupt Control
0: Disable
1: Enable
- Bit 2 **PWMD2E:** PWM2 Duty match interrupt Control
0: Disable
1: Enable
- Bit 1 **PWMD1E:** PWM1 Duty match interrupt Control
0: Disable
1: Enable
- Bit 0 **PWMD0E:** PWM0 Duty match interrupt Control
0: Disable
1: Enable

MFI3 Register

Bit	7	6	5	4	3	2	1	0
Name	TM1AF	TM1PF	TM0AF	TM0PF	TM1AE	TM1PE	TM0AE	TM0PE
R/W	R/W	R/W	R/W	R/W	R/W	R/W	R/W	R/W
POR	0	0	0	0	0	0	0	0

- Bit 7 **TM1AF:** TM1 Comparator A match interrupt request flag
0: No request
1: Interrupt request
- Bit 6 **TM1PF:** TM1 Comparator P match interrupt request flag
0: No request
1: Interrupt request
- Bit 5 **TM0AF:** TM0 Comparator A match interrupt request flag
0: No request
1: Interrupt request
- Bit 4 **TM0PF:** TM0 Comparator P match interrupt request flag
0: No request
1: Interrupt request
- Bit 3 **TM1AE:** TM1 Comparator A match interrupt control
0: Disable
1: Enable
- Bit 2 **TM1PE:** TM1 Comparator P match interrupt control
0: Disable
1: Enable
- Bit 1 **TM0AE:** TM0 Comparator A match interrupt control
0: Disable
1: Enable
- Bit 0 **TM0PE:** TM0 Comparator P match interrupt control
0: Disable
1: Enable

MF14 Register

Bit	7	6	5	4	3	2	1	0
Name	—	—	TM2AF	TM2PF	—	—	TM2AE	TM2PE
R/W	—	—	R/W	R/W	—	—	R/W	R/W
POR	—	—	0	0	—	—	0	0

- Bit 7 ~6 Unimplemented, read as "0"
- Bit 5 **TM2AF:** TM2 Comparator A match interrupt request flag
 0: No request
 1: Interrupt request
- Bit 4 **TM2PF:** TM2 Comparator P match interrupt request flag
 0: No request
 1: Interrupt request
- Bit 3~2 Unimplemented, read as "0"
- Bit 1 **TM2AE:** TM2 Comparator A match interrupt control
 0: Disable
 1: Enable
- Bit 0 **TM2PE:** TM2 Comparator P match interrupt control
 0: Disable
 1: Enable

Interrupt Operation

When the conditions for an interrupt event occur, such as a TM Compare P or Compare A match or A/D conversion completion etc, the relevant interrupt request flag will be set. Whether the request flag actually generates a program jump to the relevant interrupt vector is determined by the condition of the interrupt enable bit. If the enable bit is set high then the program will jump to its relevant vector; if the enable bit is zero then although the interrupt request flag is set an actual interrupt will not be generated and the program will not jump to the relevant interrupt vector. The global interrupt enable bit, if cleared to zero, will disable all interrupts.

When an interrupt is generated, the Program Counter, which stores the address of the next instruction to be executed, will be transferred onto the stack. The Program Counter will then be loaded with a new address which will be the value of the corresponding interrupt vector. The microcontroller will then fetch its next instruction from this interrupt vector. The instruction at this vector will usually be a "JMP" which will jump to another section of program which is known as the interrupt service routine. Here is located the code to control the appropriate interrupt. The interrupt service routine must be terminated with a "RETI", which retrieves the original Program Counter address from the stack and allows the microcontroller to continue with normal execution at the point where the interrupt occurred.

The various interrupt enable bits, together with their associated request flags, are shown in the accompanying diagrams with their order of priority. Some interrupt sources have their own individual vector while others share the same multi-function interrupt vector. Once an interrupt subroutine is serviced, all the other interrupts will be blocked, as the global interrupt enable bit, EMI bit will be cleared automatically. This will prevent any further interrupt nesting from occurring. However, if other interrupt requests occur during this interval, although the interrupt will not be immediately serviced, the request flag will still be recorded.

If an interrupt requires immediate servicing while the program is already in another interrupt service routine, the EMI bit should be set after entering the routine, to allow interrupt nesting. If the stack is full, the interrupt request will not be acknowledged, even if the related interrupt is enabled, until the Stack Pointer is decremented. If immediate service is desired, the stack must be prevented from becoming full. In case of simultaneous requests, the accompanying diagram shows the priority that is applied. All of the interrupt request flags when set will wake-up the device if it is in SLEEP or IDLE Mode, however to prevent a wake-up from occurring the corresponding flag should be set before the device is in SLEEP or IDLE Mode.

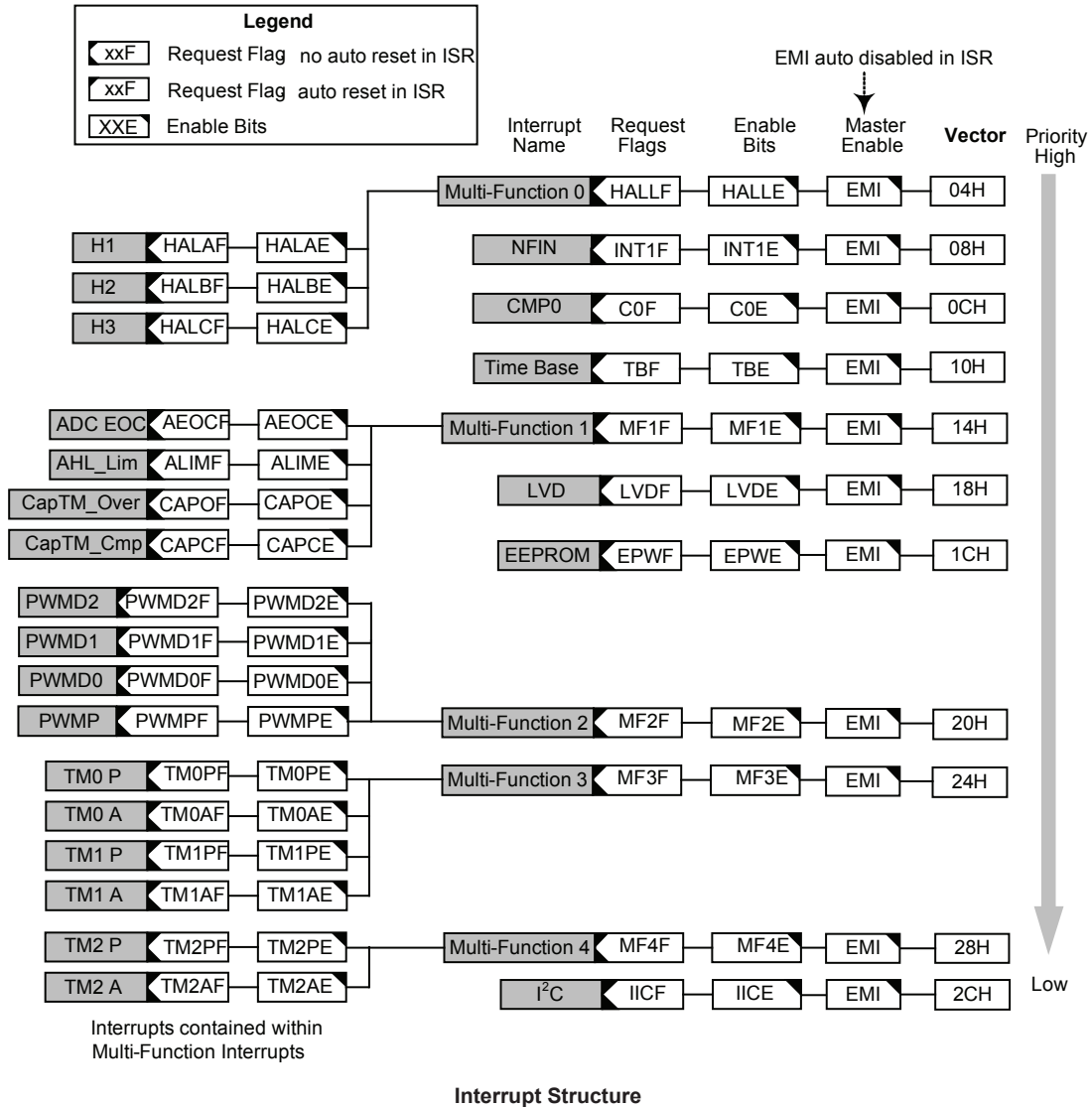

External Interrupt 0

The external interrupt 0, also known as the Hall Sensor interrupt, is a Multi-function Interrupt. It is controlled by signal transitions on the pins, Hall Sensor input pins, H1, H2 and H3. An external interrupt request will take place when the external interrupt request flag, HALAF, HALBF or HALCF is set, which will occur when a transition, appears on the external interrupt pins. To allow the program to branch to its respective interrupt vector address, the global interrupt enable bit, EMI, and the Multi-function interrupt controlled bit, HALLE must first be set.

When the Multi-function interrupt controlled bit HALLE is enabled and the stack is not full, and either one of the interrupts contained within each of Multi-function interrupt occurs, a subroutine call to one of the Multi-function interrupt vectors will take place. When the interrupt is serviced, the EMI bit will be automatically cleared to disable other interrupts and the related Multi-Function request flag HALLF, will be automatically reset, but the Multi-function interrupt request flags, HALAF,HALBF,HALCF, must be manually cleared by the application program.

External Interrupt 1

The external interrupt 1 is controlled by signal transitions on the pin NFIN. An external interrupt request will take place when the external interrupt request flag, INT1F, is set, which will occur when a transition appears on the external interrupt pin. To allow the program to branch to its respective interrupt vector address, the global interrupt enable bit, EMI, and respective external interrupt enable bit, INT1E, must first be set. When the interrupt is enabled, the stack is not full and the correct transition type appears on the external interrupt pin, a subroutine call to the external interrupt vector, will take place. When the interrupt is serviced, the external interrupt request flag, INT1F, will be automatically reset and the EMI bit will be automatically cleared to disable other interrupts. Note that any pull-high resistor selections on the external interrupt pins will remain valid even if the pin is used as an external interrupt input.

Comparator Interrupt

The comparator interrupt is controlled by the internal comparator 0. A comparator interrupt request will take place when the comparator interrupt request flag, C0F, is set, a situation that will occur when the comparator output changes state. To allow the program to branch to its respective interrupt vector address, the global interrupt enable bit, EMI, and comparator interrupt enable bit, C0E, must first be set. When the interrupt is enabled, the stack is not full and the comparator inputs generate a comparator output transition, a subroutine call to the comparator interrupt vector, will take place. When the interrupt is serviced, the comparator interrupt request flag, C0F, will be automatically reset and the EMI bit will be automatically cleared to disable other interrupts.

Time Base Interrupt

The function of the Time Base Interrupt is to provide regular time signal in the form of an internal interrupt. It is controlled by the overflow signal from its timer function. When this happens its interrupt request flag, TBF will be set. To allow the program to branch to its interrupt vector address, the global interrupt enable bit, EMI and Time Base enable bit, TBE, must first be set. When the interrupt is enabled, the stack is not full and the Time Base overflow, a subroutine call to its vector location will take place. When the interrupt is serviced, the interrupt request flag, TBF, will be automatically reset and the EMI bit will be cleared to disable other interrupts.

The purpose of the Time Base Interrupt is to provide an interrupt signal at fixed time periods. Its clock source originates from the internal clock source f_{TB} . This f_{TB} input clock passes through a divider, the division ratio of which is selected by programming the appropriate bits in the TBC register to obtain longer interrupt periods whose value ranges. The clock source that generates f_{TB} , which in turn controls the Time Base interrupt period, can originate from several different sources, as shown in the System Operating Mode section.

TBC register

Bit	7	6	5	4	3	2	1	0
Name	TBON	TBCK	TB1	TB0	—	—	—	—
R/W	R/W	R/W	R/W	R/W	—	—	—	—
POR	0	0	1	1	—	—	—	—

- Bit 7 **TBON:** TB Control
0: Disable
1: Enable
- Bit 6 **TBCK:** Select f_{TB} Clock
0: f_{TB}
1: $f_{SYS}/4$
- Bit 5~4 **TB1~TB0:** Select Time Base Time-out Period
00: $4096/f_{TB}$
01: $8192/f_{TB}$
10: $16384/f_{TB}$
11: $32768/f_{TB}$
- Bit 3~0 Unimplemented, read as "0"

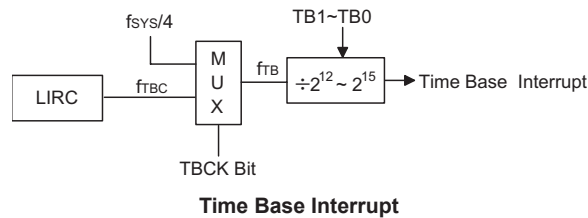

Multi-function Interrupt

Within this device are five Multi-function interrupts. Unlike the other independent interrupts, these interrupts have no independent source, but rather are formed from other existing interrupt sources, namely the Hall Sensor interrupts, A/D interrupts, PWM Module interrupts, CAPTM Interrupts, TM Interrupts.

A Multi-function interrupt request will take place when any of the Multi-function interrupt request flags, HALLF and MF1F~MF4F are set. The Multi-function interrupt flags will be set when any of their included functions generate an interrupt request flag. To allow the program to branch to its respective interrupt vector address, when the Multi-function interrupt is enabled and the stack is not full, and either one of the interrupts contained within each of Multi-function interrupt occurs, a subroutine call to one of the Multi-function interrupt vectors will take place. When the interrupt is serviced, the related Multi-Function request flag, will be automatically reset and the EMI bit will be automatically cleared to disable other interrupts.

However, it must be noted that, although the Multi-function Interrupt flags will be automatically reset when the interrupt is serviced, the request flags from the original source of the Multi-function interrupts, namely the Hall Sensor interrupts, A/D interrupts, PWM Module interrupts, CAPTM Interrupts, TM Interrupts, will not be automatically reset and must be manually reset by the application program.

A/D Converter Interrupt

The A/D Converter has two interrupts. All of them are contained in Multi-function interrupt. The one is controlled by the termination of an A/D conversion process. An A/D Converter interrupt request will take place when the A/D Converter Interrupt request flag, ALIMF, is set, which occurs when the A/D conversion process finishes. The other is controlled by the ADCHVE/ADCLVE bit in the ADCR1 register and the value in the ADLVDH/ADLVDL and ADHVDH/ADHVDL boundary control registers. An A/D Converter Interrupt request will take place after EOC comparing. To allow the program to branch to its respective interrupt vector address, the global interrupt enable bit, EMI, and A/D Interrupt enable bit, AEOCE or ALIME, must first be set. When the interrupt is enabled, the stack is not full and the A/D conversion process has ended or after EOC comparing a subroutine call to the A/D Converter Interrupt vector, will take place. When the interrupt is serviced, the A/D Converter Interrupt flag, AEOCF or ALIME, will be automatically cleared. The EMI bit will also be automatically cleared to disable other interrupts.

PWM Module Interrupts

The PWM Module has four interrupts. All of them are contained in Multi-function interrupt, which is known as PWMDn and PWMP. They are the Duty or the Period matching of the PWM Module. A PWM interrupt request will take place when the PWM interrupt request flag, PWMDnF or PWMPF, is set, which occurs when the PWM Duty or PWM Period matches. When the interrupt is enabled, the stack is not full and PWM Duty or PWM Period matches, a subroutine call to this vector location will take place. When the interrupt is serviced, the EMI bit will be automatically cleared to disable other interrupts and the related Multi-Function request flag will be automatically reset, but the interrupt request flag, PWMDnF or PWMPF, must be manually cleared by the application program.

CAPTM Module Interrupt

The CAPTM Module has two interrupts. All of them are contained within the Multi-function Interrupt, which are known as CapTM_Over and CapTM_Cmp. A CAPTM Interrupt request will take place when the CAPTM Interrupts request flag, CAPOF or CAPCF, is set, which occurs when CAPTM capture overflows or compare matches. To allow the program to branch to their respective interrupt vector address, the global interrupt enable bit, EMI, and the CAPTM Interrupt enable bit, and Multi-function interrupt enable bit, must first be set. When the interrupt is enabled, the stack is not full and CAPTM capture overflows or compare matches, a subroutine call to the respective Multi-function Interrupt vector, will take place. When the CAPTM Interrupt is serviced, the EMI bit will be automatically cleared to disable other interrupts, however only the Multi-function interrupt request flag will be also automatically cleared. As the CAPOF and CAPCF flag will not be automatically cleared, it has to be cleared by the application program.

TM Interrupt

The Compact and Standard Type TMs have two interrupts each. All of the TM interrupts are contained within the Multi-function Interrupts. For each of the Compact Type TM and Standard Type TMs there are two interrupt request flags TnPF and TnAF and two enable bits TnPE and TnAE. A TM interrupt request will take place when any of the TM request flags is set, a situation which occurs when a TM comparator P or A match situation happens.

To allow the program to branch to its respective interrupt vector address, the global interrupt enable bit, EMI, respective TM Interrupt enable bit, and relevant Multi-function Interrupt enable bit, MFnE, must first be set. When the interrupt is enabled, the stack is not full and a TM comparator match situation occurs, a subroutine call to the relevant Multi-function Interrupt vector locations, will take place. When the TM interrupt is serviced, the EMI bit will be automatically cleared to disable other interrupts, however only the related MFnF flag will be automatically cleared. As the TM interrupt request flags will not be automatically cleared, they have to be cleared by the application program.

EEPROM Interrupt

An EEPROM Interrupt will take place when the EEPROM Interrupt request flag, EPWF, is set, which occurs when an EEPROM Write cycle ends. To allow the program to branch to its respective interrupt vector address, the global interrupt enable bit, EMI and EEPROM Interrupt enable bit, EPWE, must first be set. When the interrupt is enabled, the stack is not full and an EEPROM Write cycle ends, a subroutine call to the respective EEPROM Interrupt vector, will take place. When the EEPROM interrupt is serviced, the interrupt request flag, EPWF, will be automatically reset and the EMI bit will be cleared to disable other interrupts

LVD Interrupt

An LVD Interrupt request will take place when the LVD Interrupt request flag, LVDF, is set, which occurs when the Low Voltage Detector function detects a low power supply voltage. To allow the program to branch to its respective interrupt vector address, the global interrupt enable bit, EMI, and Low Voltage Interrupt enable bit, LVDE, must first be set. When the interrupt is enabled, the stack is not full and a low voltage condition occurs, a subroutine call to the LVD Interrupt vector, will take place. When the EEPROM interrupt is serviced, the interrupt request flag, LVDF, will be automatically reset and the EMI bit will be cleared to disable other interrupts.

I²C Interrupt

A I²C Interrupt request will take place when the I²C Interrupt request flag, IICF, is set, which occurs when a byte of data has been received or transmitted by the I²C interface. To allow the program to branch to its respective interrupt vector address, the global interrupt enable bit, EMI, and the Serial Interface Interrupt enable bit, IICE, must first be set. When the interrupt is enabled, the stack is not full and a byte of data has been transmitted or received by the I²C interface, a subroutine call to the respective Interrupt vector, will take place. When the I²C Interface Interrupt is serviced, the interrupt request flag, IICF, will be automatically reset and the EMI bit will be cleared to disable other interrupts.

Interrupt Wake-up Function

Each of the interrupt functions has the capability of waking up the microcontroller when in the SLEEP or IDLE Mode. A wake-up is generated when an interrupt request flag changes from low to high and is independent of whether the interrupt is enabled or not. Therefore, even though the device is in the SLEEP or IDLE Mode and its system oscillator stopped, situations such as external edge transitions on the external interrupt pins, a low power supply voltage or comparator input change may cause their respective interrupt flag to be set high and consequently generate an interrupt. Care must therefore be taken if spurious wake-up situations are to be avoided. If an interrupt wake-up function is to be disabled then the corresponding interrupt request flag should be set high before the device enters the SLEEP or IDLE Mode. The interrupt enable bits have no effect on the interrupt wake-up function.

Programming Considerations

By disabling the relevant interrupt enable bits, a requested interrupt can be prevented from being serviced, however, once an interrupt request flag is set, it will remain in this condition in the interrupt register until the corresponding interrupt is serviced or until the request flag is cleared by the application program.

Where a certain interrupt is contained within a Multi-function interrupt, then when the interrupt service routine is executed, as only the Multi-function interrupt request flags, HALLF and MF1F~MF4F, will be automatically cleared, the individual request flag for the function needs to be cleared by the application program.

It is recommended that programs do not use the "CALL" instruction within the interrupt service subroutine. Interrupts often occur in an unpredictable manner or need to be serviced immediately. If only one stack is left and the interrupt is not well controlled, the original control sequence will be damaged once a CALL subroutine is executed in the interrupt subroutine.

Every interrupt has the capability of waking up the microcontroller when it is in SLEEP or IDLE Mode, the wake up being generated when the interrupt request flag changes from low to high. If it is required to prevent a certain interrupt from waking up the microcontroller then its respective request flag should be first set high before enter SLEEP or IDLE Mode.

As only the Program Counter is pushed onto the stack, then when the interrupt is serviced, if the contents of the accumulator, status register or other registers are altered by the interrupt service program, their contents should be saved to the memory at the beginning of the interrupt service routine.

To return from an interrupt subroutine, either a RET or RETI instruction may be executed. The RETI instruction in addition to executing a return to the main program also automatically sets the EMI bit high to allow further interrupts. The RET instruction however only executes a return to the main program leaving the EMI bit in its present zero state and therefore disabling the execution of further interrupts.

Low Voltage Detector – LVD

The device has a Low Voltage Detector function, also known as LVD. This enables the device to monitor the power supply voltage, V_{DD} , and provides a warning signal should it fall below a certain level. This function may be especially useful in battery applications where the supply voltage will gradually reduce as the battery ages, as it allows an early warning battery low signal to be generated. The Low Voltage Detector also has the capability of generating an interrupt signal.

LVD Register

The Low Voltage Detector function is controlled using a single register with the name LVDC. Three bits in this register, VLVD2~VLVD0, are used to select a fixed voltage below which a low voltage condition will be determined. A low voltage condition is indicated when the LVDO bit is set. If the LVDO bit is low, this indicates that the V_{DD} voltage is above the preset low voltage value. The LVDEN bit is used to control the overall on/off function of the low voltage detector. Setting the bit high will enable the low voltage detector. Clearing the bit to zero will switch off the internal low voltage detector circuits. As the low voltage detector will consume a certain amount of power, it may be desirable to switch off the circuit when not in use, an important consideration in power sensitive battery powered applications.

LVDC Register

Bit	7	6	5	4	3	2	1	0
Name	—	—	LVDO	LVDEN	—	VLVD2	VLVD1	VLVD0
R/W	—	—	R	R/W	—	R/W	R/W	R/W
POR	—	—	0	0	—	0	0	0

- Bit 7 ~ 6 Unimplemented, read as "0"
- Bit 5 **LVDO:** LVD Output Flag
 0: No Low Voltage Detect
 1: Low Voltage Detect
- Bit 4 **LVDEN:** Low Voltage Detector Control
 0: Disable
 1: Enable
- Bit 3 Unimplemented, read as "0"
- Bit 2~0 **VLVD2 ~ VLVD0:** Select LVD Voltage
 000: 3.6V
 001: 3.6V
 010: 3.6V
 011: 3.6V
 100: 3.6V
 101: 3.6V
 110: 3.6V
 111: 3.6V

LVD Operation

The Low Voltage Detector function operates by comparing the power supply voltage, V_{DD} , with a pre-specified voltage level stored in the LVDC register. This has a voltage of 3.6V. When the power supply voltage, V_{DD} , falls below this pre-determined value, the LVDO bit will be set high indicating a low power supply voltage condition. The Low Voltage Detector function is supplied by a reference voltage which will be automatically enabled. When the device is powered down the low voltage detector will remain active if the LVDEN bit is high. After enabling the Low Voltage Detector, a time delay t_{LVDS} should be allowed for the circuitry to stabilise before reading the LVDO bit. Note also that as the V_{DD} voltage may rise and fall rather slowly, at the voltage nears that of V_{LVD} , there may be multiple bit LVDO transitions.

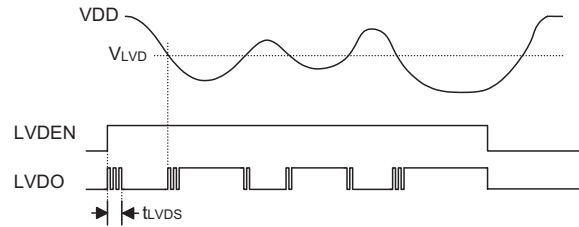

LVD Operation

The Low Voltage Detector also has its own interrupt which is contained within one of the Multi-function interrupts, providing an alternative means of low voltage detection, in addition to polling the LVDO bit. The interrupt will only be generated after a delay of t_{LVD} after the LVDO bit has been set high by a low voltage condition. When the device is powered down the Low Voltage Detector will remain active if the LVDEN bit is high. In this case, the LVDF interrupt request flag will be set, causing an interrupt to be generated if V_{DD} falls below the preset LVD voltage. This will cause the device to wake-up from the SLEEP or IDLE Mode, however if the Low Voltage Detector wake up function is not required then the LVDF flag should be first set high before the device enters the SLEEP or IDLE Mode.

Application Circuits

Three Phase BLDC Hall Sensor Solution ($V_B=24V$)

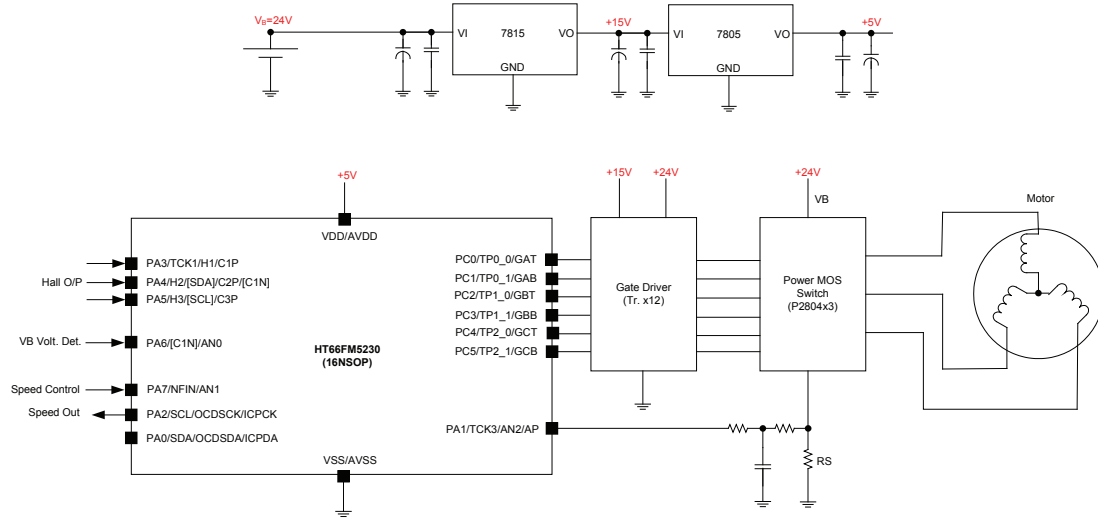

Three Phase BLDC Hall Sensorless Solution ($V_B=24V$)

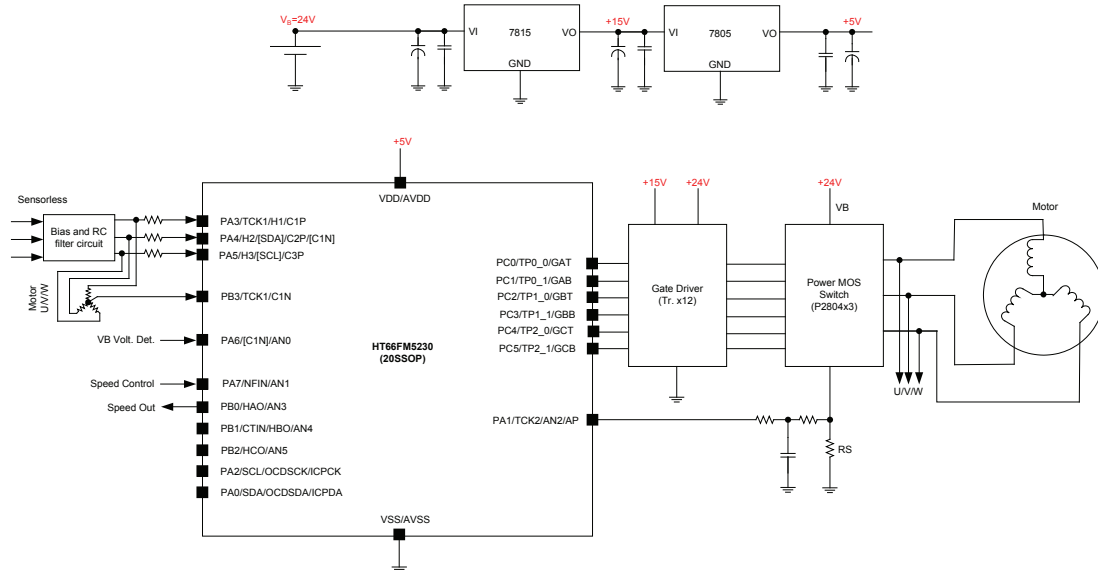

Single Phase BLDC Hall Sensor Solution ($V_B=12V$)

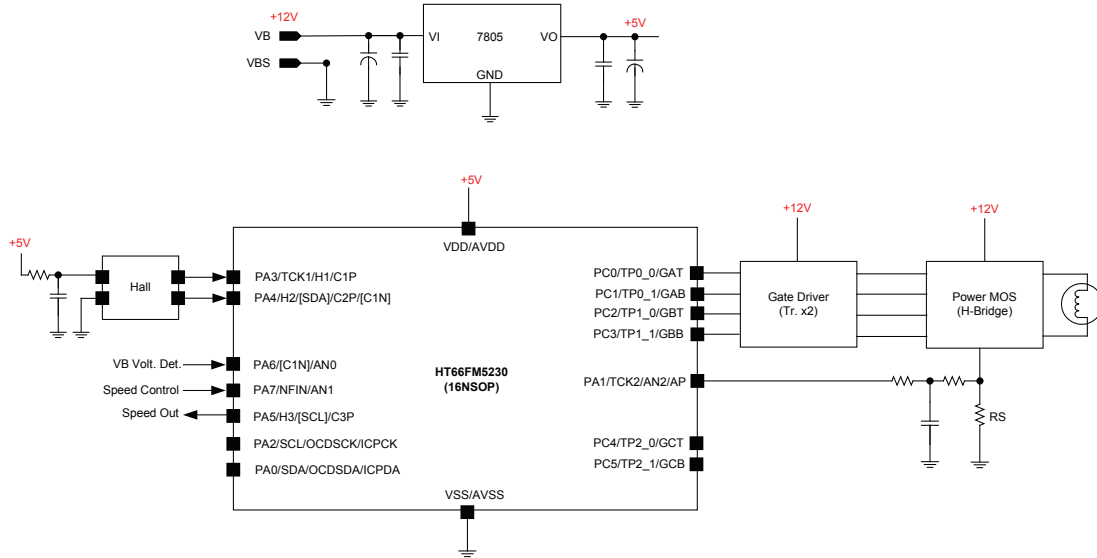

Single Phase BLDC Hall Sensorless Solution ($V_B=12V$)

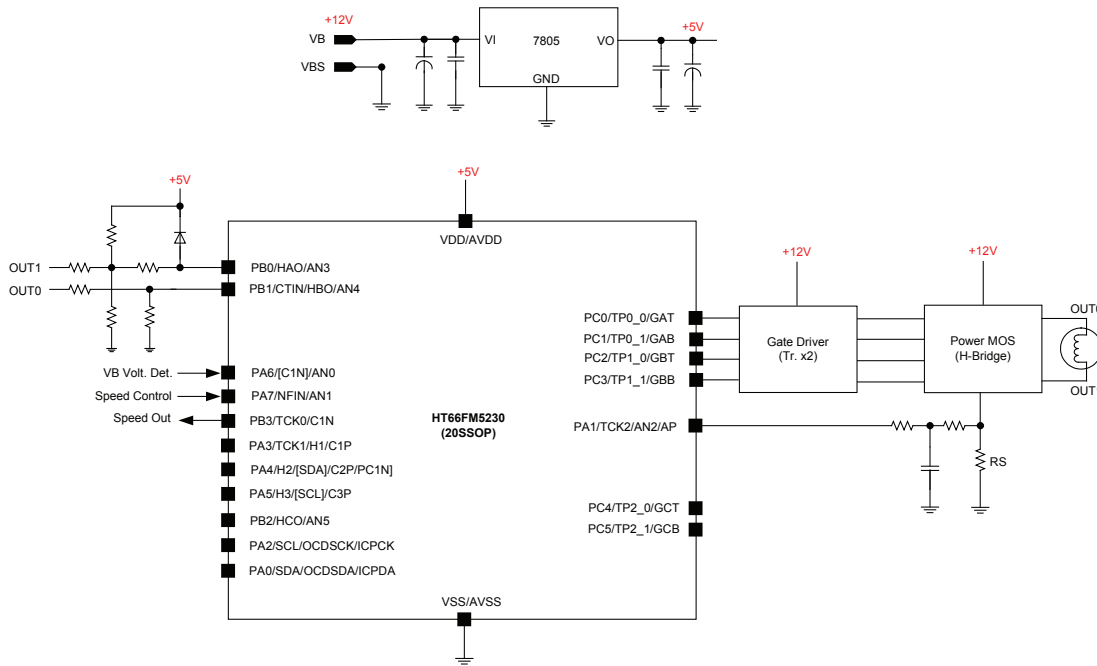

Instruction Set

Introduction

Central to the successful operation of any microcontroller is its instruction set, which is a set of program instruction codes that directs the microcontroller to perform certain operations. In the case of Holtek microcontroller, a comprehensive and flexible set of over 60 instructions is provided to enable programmers to implement their application with the minimum of programming overheads.

For easier understanding of the various instruction codes, they have been subdivided into several functional groupings.

Instruction Timing

Most instructions are implemented within one instruction cycle. The exceptions to this are branch, call, or table read instructions where two instruction cycles are required. One instruction cycle is equal to 4 system clock cycles, therefore in the case of an 8MHz system oscillator, most instructions would be implemented within 0.5 μ s and branch or call instructions would be implemented within 1 μ s. Although instructions which require one more cycle to implement are generally limited to the JMP, CALL, RET, RETI and table read instructions, it is important to realize that any other instructions which involve manipulation of the Program Counter Low register or PCL will also take one more cycle to implement. As instructions which change the contents of the PCL will imply a direct jump to that new address, one more cycle will be required. Examples of such instructions would be "CLR PCL" or "MOV PCL, A". For the case of skip instructions, it must be noted that if the result of the comparison involves a skip operation then this will also take one more cycle, if no skip is involved then only one cycle is required.

Moving and Transferring Data

The transfer of data within the microcontroller program is one of the most frequently used operations. Making use of three kinds of MOV instructions, data can be transferred from registers to the Accumulator and vice-versa as well as being able to move specific immediate data directly into the Accumulator. One of the most important data transfer applications is to receive data from the input ports and transfer data to the output ports.

Arithmetic Operations

The ability to perform certain arithmetic operations and data manipulation is a necessary feature of most microcontroller applications. Within the Holtek microcontroller instruction set are a range of add and subtract instruction mnemonics to enable the necessary arithmetic to be carried out. Care must be taken to ensure correct handling of carry and borrow data when results exceed 255 for addition and less than 0 for subtraction. The increment and decrement instructions INC, INCA, DEC and DECA provide a simple means of increasing or decreasing by a value of one of the values in the destination specified.

Logical and Rotate Operation

The standard logical operations such as AND, OR, XOR and CPL all have their own instruction within the Holtek microcontroller instruction set. As with the case of most instructions involving data manipulation, data must pass through the Accumulator which may involve additional programming steps. In all logical data operations, the zero flag may be set if the result of the operation is zero. Another form of logical data manipulation comes from the rotate instructions such as RR, RL, RRC and RLC which provide a simple means of rotating one bit right or left. Different rotate instructions exist depending on program requirements. Rotate instructions are useful for serial port programming applications where data can be rotated from an internal register into the Carry bit from where it can be examined and the necessary serial bit set high or low. Another application which rotate data operations are used is to implement multiplication and division calculations.

Branches and Control Transfer

Program branching takes the form of either jumps to specified locations using the JMP instruction or to a subroutine using the CALL instruction. They differ in the sense that in the case of a subroutine call, the program must return to the instruction immediately when the subroutine has been carried out. This is done by placing a return instruction "RET" in the subroutine which will cause the program to jump back to the address right after the CALL instruction. In the case of a JMP instruction, the program simply jumps to the desired location. There is no requirement to jump back to the original jumping off point as in the case of the CALL instruction. One special and extremely useful set of branch instructions are the conditional branches. Here a decision is first made regarding the condition of a certain data memory or individual bits. Depending upon the conditions, the program will continue with the next instruction or skip over it and jump to the following instruction. These instructions are the key to decision making and branching within the program perhaps determined by the condition of certain input switches or by the condition of internal data bits.

Bit Operations

The ability to provide single bit operations on Data Memory is an extremely flexible feature of all Holtek microcontrollers. This feature is especially useful for output port bit programming where individual bits or port pins can be directly set high or low using either the "SET [m].i" or "CLR [m].i" instructions respectively. The feature removes the need for programmers to first read the 8-bit output port, manipulate the input data to ensure that other bits are not changed and then output the port with the correct new data. This read-modify-write process is taken care of automatically when these bit operation instructions are used.

Table Read Operations

Data storage is normally implemented by using registers. However, when working with large amounts of fixed data, the volume involved often makes it inconvenient to store the fixed data in the Data Memory. To overcome this problem, Holtek microcontrollers allow an area of Program Memory to be setup as a table where data can be directly stored. A set of easy to use instructions provides the means by which this fixed data can be referenced and retrieved from the Program Memory.

Other Operations

In addition to the above functional instructions, a range of other instructions also exist such as the "HALT" instruction for Power-down operations and instructions to control the operation of the Watchdog Timer for reliable program operations under extreme electric or electromagnetic environments. For their relevant operations, refer to the functional related sections.

Instruction Set Summary

The following table depicts a summary of the instruction set categorised according to function and can be consulted as a basic instruction reference using the following listed conventions.

Table Conventions

- x: Bits immediate data
- m: Data Memory address
- A: Accumulator
- i: 0~7 number of bits
- addr: Program memory address

Mnemonic	Description	Cycles	Flag Affected
Arithmetic			
ADD A,[m]	Add Data Memory to ACC	1	Z, C, AC, OV
ADDM A,[m]	Add ACC to Data Memory	1 ^{Note}	Z, C, AC, OV
ADD A,x	Add immediate data to ACC	1	Z, C, AC, OV
ADC A,[m]	Add Data Memory to ACC with Carry	1	Z, C, AC, OV
ADCM A,[m]	Add ACC to Data memory with Carry	1 ^{Note}	Z, C, AC, OV
SUB A,x	Subtract immediate data from the ACC	1	Z, C, AC, OV
SUB A,[m]	Subtract Data Memory from ACC	1	Z, C, AC, OV
SUBM A,[m]	Subtract Data Memory from ACC with result in Data Memory	1 ^{Note}	Z, C, AC, OV
SBC A,[m]	Subtract Data Memory from ACC with Carry	1	Z, C, AC, OV
SBCM A,[m]	Subtract Data Memory from ACC with Carry, result in Data Memory	1 ^{Note}	Z, C, AC, OV
DAA [m]	Decimal adjust ACC for Addition with result in Data Memory	1 ^{Note}	C
Logic Operation			
AND A,[m]	Logical AND Data Memory to ACC	1	Z
OR A,[m]	Logical OR Data Memory to ACC	1	Z
XOR A,[m]	Logical XOR Data Memory to ACC	1	Z
ANDM A,[m]	Logical AND ACC to Data Memory	1 ^{Note}	Z
ORM A,[m]	Logical OR ACC to Data Memory	1 ^{Note}	Z
XORM A,[m]	Logical XOR ACC to Data Memory	1 ^{Note}	Z
AND A,x	Logical AND immediate Data to ACC	1	Z
OR A,x	Logical OR immediate Data to ACC	1	Z
XOR A,x	Logical XOR immediate Data to ACC	1	Z
CPL [m]	Complement Data Memory	1 ^{Note}	Z
CPLA [m]	Complement Data Memory with result in ACC	1	Z
Increment & Decrement			
INCA [m]	Increment Data Memory with result in ACC	1	Z
INC [m]	Increment Data Memory	1 ^{Note}	Z
DECA [m]	Decrement Data Memory with result in ACC	1	Z
DEC [m]	Decrement Data Memory	1 ^{Note}	Z
Rotate			
RRA [m]	Rotate Data Memory right with result in ACC	1	None
RR [m]	Rotate Data Memory right	1 ^{Note}	None
RRCA [m]	Rotate Data Memory right through Carry with result in ACC	1	C
RRC [m]	Rotate Data Memory right through Carry	1 ^{Note}	C
RLA [m]	Rotate Data Memory left with result in ACC	1	None
RL [m]	Rotate Data Memory left	1 ^{Note}	None
RLCA [m]	Rotate Data Memory left through Carry with result in ACC	1	C
RLC [m]	Rotate Data Memory left through Carry	1 ^{Note}	C

Mnemonic	Description	Cycles	Flag Affected
Data Move			
MOV A,[m]	Move Data Memory to ACC	1	None
MOV [m],A	Move ACC to Data Memory	1 ^{Note}	None
MOV A,x	Move immediate data to ACC	1	None
Bit Operation			
CLR [m].i	Clear bit of Data Memory	1 ^{Note}	None
SET [m].i	Set bit of Data Memory	1 ^{Note}	None
Branch			
JMP addr	Jump unconditionally	2	None
SZ [m]	Skip if Data Memory is zero	1 ^{Note}	None
SZA [m]	Skip if Data Memory is zero with data movement to ACC	1 ^{Note}	None
SZ [m].i	Skip if bit i of Data Memory is zero	1 ^{Note}	None
SNZ [m].i	Skip if bit i of Data Memory is not zero	1 ^{Note}	None
SIZ [m]	Skip if increment Data Memory is zero	1 ^{Note}	None
SDZ [m]	Skip if decrement Data Memory is zero	1 ^{Note}	None
SIZA [m]	Skip if increment Data Memory is zero with result in ACC	1 ^{Note}	None
SDZA [m]	Skip if decrement Data Memory is zero with result in ACC	1 ^{Note}	None
CALL addr	Subroutine call	2	None
RET	Return from subroutine	2	None
RET A,x	Return from subroutine and load immediate data to ACC	2	None
RETI	Return from interrupt	2	None
Table Read			
TABRD [m]	Read table to TBLH and Data Memory	2 ^{Note}	None
TABRDL [m]	Read table (last page) to TBLH and Data Memory	2 ^{Note}	None
Miscellaneous			
NOP	No operation	1	None
CLR [m]	Clear Data Memory	1 ^{Note}	None
SET [m]	Set Data Memory	1 ^{Note}	None
CLR WDT	Clear Watchdog Timer	1	TO, PDF
CLR WDT1	Pre-clear Watchdog Timer	1	TO, PDF
CLR WDT2	Pre-clear Watchdog Timer	1	TO, PDF
SWAP [m]	Swap nibbles of Data Memory	1 ^{Note}	None
SWAPA [m]	Swap nibbles of Data Memory with result in ACC	1	None
HALT	Enter power down mode	1	TO, PDF

Note: 1. For skip instructions, if the result of the comparison involves a skip then two cycles are required, if no skip takes place only one cycle is required.

2. Any instruction which changes the contents of the PCL will also require 2 cycles for execution.

3. For the "CLR WDT1" and "CLR WDT2" instructions the TO and PDF flags may be affected by the execution status. The TO and PDF flags are cleared after both "CLR WDT1" and "CLR WDT2" instructions are consecutively executed. Otherwise the TO and PDF flags remain unchanged.

Instruction Definition

ADC A,[m]	Add Data Memory to ACC with Carry
Description	The contents of the specified Data Memory, Accumulator and the carry flag are added. The result is stored in the Accumulator.
Operation	$ACC \leftarrow ACC + [m] + C$
Affected flag(s)	OV, Z, AC, C
ADCM A,[m]	Add ACC to Data Memory with Carry
Description	The contents of the specified Data Memory, Accumulator and the carry flag are added. The result is stored in the specified Data Memory.
Operation	$[m] \leftarrow ACC + [m] + C$
Affected flag(s)	OV, Z, AC, C
ADD A,[m]	Add Data Memory to ACC
Description	The contents of the specified Data Memory and the Accumulator are added. The result is stored in the Accumulator.
Operation	$ACC \leftarrow ACC + [m]$
Affected flag(s)	OV, Z, AC, C
ADD A,x	Add immediate data to ACC
Description	The contents of the Accumulator and the specified immediate data are added. The result is stored in the Accumulator.
Operation	$ACC \leftarrow ACC + x$
Affected flag(s)	OV, Z, AC, C
ADDM A,[m]	Add ACC to Data Memory
Description	The contents of the specified Data Memory and the Accumulator are added. The result is stored in the specified Data Memory.
Operation	$[m] \leftarrow ACC + [m]$
Affected flag(s)	OV, Z, AC, C
AND A,[m]	Logical AND Data Memory to ACC
Description	Data in the Accumulator and the specified Data Memory perform a bitwise logical AND operation. The result is stored in the Accumulator.
Operation	$ACC \leftarrow ACC \text{ "AND" } [m]$
Affected flag(s)	Z
AND A,x	Logical AND immediate data to ACC
Description	Data in the Accumulator and the specified immediate data perform a bit wise logical AND operation. The result is stored in the Accumulator.
Operation	$ACC \leftarrow ACC \text{ "AND" } x$
Affected flag(s)	Z
ANDM A,[m]	Logical AND ACC to Data Memory
Description	Data in the specified Data Memory and the Accumulator perform a bitwise logical AND operation. The result is stored in the Data Memory.
Operation	$[m] \leftarrow ACC \text{ "AND" } [m]$
Affected flag(s)	Z

CALL addr	Subroutine call
Description	Unconditionally calls a subroutine at the specified address. The Program Counter then increments by 1 to obtain the address of the next instruction which is then pushed onto the stack. The specified address is then loaded and the program continues execution from this new address. As this instruction requires an additional operation, it is a two cycle instruction.
Operation	Stack ← Program Counter + 1 Program Counter ← addr
Affected flag(s)	None
CLR [m]	Clear Data Memory
Description	Each bit of the specified Data Memory is cleared to 0.
Operation	[m] ← 00H
Affected flag(s)	None
CLR [m].i	Clear bit of Data Memory
Description	Bit i of the specified Data Memory is cleared to 0.
Operation	[m].i ← 0
Affected flag(s)	None
CLR WDT	Clear Watchdog Timer
Description	The TO, PDF flags and the WDT are all cleared.
Operation	WDT cleared TO ← 0 PDF ← 0
Affected flag(s)	TO, PDF
CLR WDT1	Pre-clear Watchdog Timer
Description	The TO, PDF flags and the WDT are all cleared. Note that this instruction works in conjunction with CLR WDT2 and must be executed alternately with CLR WDT2 to have effect. Repetitively executing this instruction without alternately executing CLR WDT2 will have no effect.
Operation	WDT cleared TO ← 0 PDF ← 0
Affected flag(s)	TO, PDF
CLR WDT2	Pre-clear Watchdog Timer
Description	The TO, PDF flags and the WDT are all cleared. Note that this instruction works in conjunction with CLR WDT1 and must be executed alternately with CLR WDT1 to have effect. Repetitively executing this instruction without alternately executing CLR WDT1 will have no effect.
Operation	WDT cleared TO ← 0 PDF ← 0
Affected flag(s)	TO, PDF
CPL [m]	Complement Data Memory
Description	Each bit of the specified Data Memory is logically complemented (1's complement). Bits which previously contained a 1 are changed to 0 and vice versa.
Operation	[m] ← $\overline{[m]}$
Affected flag(s)	Z

CPLA [m]	Complement Data Memory with result in ACC
Description	Each bit of the specified Data Memory is logically complemented (1's complement). Bits which previously contained a 1 are changed to 0 and vice versa. The complemented result is stored in the Accumulator and the contents of the Data Memory remain unchanged.
Operation	$ACC \leftarrow \overline{[m]}$
Affected flag(s)	Z
DAA [m]	Decimal-Adjust ACC for addition with result in Data Memory
Description	Convert the contents of the Accumulator value to a BCD (Binary Coded Decimal) value resulting from the previous addition of two BCD variables. If the low nibble is greater than 9 or if AC flag is set, then a value of 6 will be added to the low nibble. Otherwise the low nibble remains unchanged. If the high nibble is greater than 9 or if the C flag is set, then a value of 6 will be added to the high nibble. Essentially, the decimal conversion is performed by adding 00H, 06H, 60H or 66H depending on the Accumulator and flag conditions. Only the C flag may be affected by this instruction which indicates that if the original BCD sum is greater than 100, it allows multiple precision decimal addition.
Operation	$[m] \leftarrow ACC + 00H$ or $[m] \leftarrow ACC + 06H$ or $[m] \leftarrow ACC + 60H$ or $[m] \leftarrow ACC + 66H$
Affected flag(s)	C
DEC [m]	Decrement Data Memory
Description	Data in the specified Data Memory is decremented by 1.
Operation	$[m] \leftarrow [m] - 1$
Affected flag(s)	Z
DECA [m]	Decrement Data Memory with result in ACC
Description	Data in the specified Data Memory is decremented by 1. The result is stored in the Accumulator. The contents of the Data Memory remain unchanged.
Operation	$ACC \leftarrow [m] - 1$
Affected flag(s)	Z
HALT	Enter power down mode
Description	This instruction stops the program execution and turns off the system clock. The contents of the Data Memory and registers are retained. The WDT and prescaler are cleared. The power down flag PDF is set and the WDT time-out flag TO is cleared.
Operation	TO \leftarrow 0 PDF \leftarrow 1
Affected flag(s)	TO, PDF
INC [m]	Increment Data Memory
Description	Data in the specified Data Memory is incremented by 1.
Operation	$[m] \leftarrow [m] + 1$
Affected flag(s)	Z
INCA [m]	Increment Data Memory with result in ACC
Description	Data in the specified Data Memory is incremented by 1. The result is stored in the Accumulator. The contents of the Data Memory remain unchanged.
Operation	$ACC \leftarrow [m] + 1$
Affected flag(s)	Z

JMP addr	Jump unconditionally
Description	The contents of the Program Counter are replaced with the specified address. Program execution then continues from this new address. As this requires the insertion of a dummy instruction while the new address is loaded, it is a two cycle instruction.
Operation	Program Counter \leftarrow addr
Affected flag(s)	None
MOV A,[m]	Move Data Memory to ACC
Description	The contents of the specified Data Memory are copied to the Accumulator.
Operation	ACC \leftarrow [m]
Affected flag(s)	None
MOV A,x	Move immediate data to ACC
Description	The immediate data specified is loaded into the Accumulator.
Operation	ACC \leftarrow x
Affected flag(s)	None
MOV [m],A	Move ACC to Data Memory
Description	The contents of the Accumulator are copied to the specified Data Memory.
Operation	[m] \leftarrow ACC
Affected flag(s)	None
NOP	No operation
Description	No operation is performed. Execution continues with the next instruction.
Operation	No operation
Affected flag(s)	None
OR A,[m]	Logical OR Data Memory to ACC
Description	Data in the Accumulator and the specified Data Memory perform a bitwise logical OR operation. The result is stored in the Accumulator.
Operation	ACC \leftarrow ACC "OR" [m]
Affected flag(s)	Z
OR A,x	Logical OR immediate data to ACC
Description	Data in the Accumulator and the specified immediate data perform a bitwise logical OR operation. The result is stored in the Accumulator.
Operation	ACC \leftarrow ACC "OR" x
Affected flag(s)	Z
ORM A,[m]	Logical OR ACC to Data Memory
Description	Data in the specified Data Memory and the Accumulator perform a bitwise logical OR operation. The result is stored in the Data Memory.
Operation	[m] \leftarrow ACC "OR" [m]
Affected flag(s)	Z
RET	Return from subroutine
Description	The Program Counter is restored from the stack. Program execution continues at the restored address.
Operation	Program Counter \leftarrow Stack
Affected flag(s)	None

RET A,x	Return from subroutine and load immediate data to ACC
Description	The Program Counter is restored from the stack and the Accumulator loaded with the specified immediate data. Program execution continues at the restored address.
Operation	Program Counter ← Stack ACC ← x
Affected flag(s)	None
RETI	Return from interrupt
Description	The Program Counter is restored from the stack and the interrupts are re-enabled by setting the EMI bit. EMI is the master interrupt global enable bit. If an interrupt was pending when the RETI instruction is executed, the pending Interrupt routine will be processed before returning to the main program.
Operation	Program Counter ← Stack EMI ← 1
Affected flag(s)	None
RL [m]	Rotate Data Memory left
Description	The contents of the specified Data Memory are rotated left by 1 bit with bit 7 rotated into bit 0.
Operation	[m].(i+1) ← [m].i; (i=0~6) [m].0 ← [m].7
Affected flag(s)	None
RLA [m]	Rotate Data Memory left with result in ACC
Description	The contents of the specified Data Memory are rotated left by 1 bit with bit 7 rotated into bit 0. The rotated result is stored in the Accumulator and the contents of the Data Memory remain unchanged.
Operation	ACC.(i+1) ← [m].i; (i=0~6) ACC.0 ← [m].7
Affected flag(s)	None
RLC [m]	Rotate Data Memory left through Carry
Description	The contents of the specified Data Memory and the carry flag are rotated left by 1 bit. Bit 7 replaces the Carry bit and the original carry flag is rotated into bit 0.
Operation	[m].(i+1) ← [m].i; (i=0~6) [m].0 ← C C ← [m].7
Affected flag(s)	C
RLCA [m]	Rotate Data Memory left through Carry with result in ACC
Description	Data in the specified Data Memory and the carry flag are rotated left by 1 bit. Bit 7 replaces the Carry bit and the original carry flag is rotated into the bit 0. The rotated result is stored in the Accumulator and the contents of the Data Memory remain unchanged.
Operation	ACC.(i+1) ← [m].i; (i=0~6) ACC.0 ← C C ← [m].7
Affected flag(s)	C
RR [m]	Rotate Data Memory right
Description	The contents of the specified Data Memory are rotated right by 1 bit with bit 0 rotated into bit 7.
Operation	[m].i ← [m].(i+1); (i=0~6) [m].7 ← [m].0
Affected flag(s)	None

RRA [m]	Rotate Data Memory right with result in ACC
Description	Data in the specified Data Memory and the carry flag are rotated right by 1 bit with bit 0 rotated into bit 7. The rotated result is stored in the Accumulator and the contents of the Data Memory remain unchanged.
Operation	$ACC.i \leftarrow [m].(i+1); (i=0\sim6)$ $ACC.7 \leftarrow [m].0$
Affected flag(s)	None
RRC [m]	Rotate Data Memory right through Carry
Description	The contents of the specified Data Memory and the carry flag are rotated right by 1 bit. Bit 0 replaces the Carry bit and the original carry flag is rotated into bit 7.
Operation	$[m].i \leftarrow [m].(i+1); (i=0\sim6)$ $[m].7 \leftarrow C$ $C \leftarrow [m].0$
Affected flag(s)	C
RRCA [m]	Rotate Data Memory right through Carry with result in ACC
Description	Data in the specified Data Memory and the carry flag are rotated right by 1 bit. Bit 0 replaces the Carry bit and the original carry flag is rotated into bit 7. The rotated result is stored in the Accumulator and the contents of the Data Memory remain unchanged.
Operation	$ACC.i \leftarrow [m].(i+1); (i=0\sim6)$ $ACC.7 \leftarrow C$ $C \leftarrow [m].0$
Affected flag(s)	C
SBC A,[m]	Subtract Data Memory from ACC with Carry
Description	The contents of the specified Data Memory and the complement of the carry flag are subtracted from the Accumulator. The result is stored in the Accumulator. Note that if the result of subtraction is negative, the C flag will be cleared to 0, otherwise if the result is positive or zero, the C flag will be set to 1.
Operation	$ACC \leftarrow ACC - [m] - C$
Affected flag(s)	OV, Z, AC, C
SBCM A,[m]	Subtract Data Memory from ACC with Carry and result in Data Memory
Description	The contents of the specified Data Memory and the complement of the carry flag are subtracted from the Accumulator. The result is stored in the Data Memory. Note that if the result of subtraction is negative, the C flag will be cleared to 0, otherwise if the result is positive or zero, the C flag will be set to 1.
Operation	$[m] \leftarrow ACC - [m] - C$
Affected flag(s)	OV, Z, AC, C
SDZ [m]	Skip if decrement Data Memory is 0
Description	The contents of the specified Data Memory are first decremented by 1. If the result is 0 the following instruction is skipped. As this requires the insertion of a dummy instruction while the next instruction is fetched, it is a two cycle instruction. If the result is not 0 the program proceeds with the following instruction.
Operation	$[m] \leftarrow [m] - 1$ Skip if $[m]=0$
Affected flag(s)	None

SDZA [m]	Skip if decrement Data Memory is zero with result in ACC
Description	The contents of the specified Data Memory are first decremented by 1. If the result is 0, the following instruction is skipped. The result is stored in the Accumulator but the specified Data Memory contents remain unchanged. As this requires the insertion of a dummy instruction while the next instruction is fetched, it is a two cycle instruction. If the result is not 0, the program proceeds with the following instruction.
Operation	$ACC \leftarrow [m] - 1$ Skip if $ACC=0$
Affected flag(s)	None
SET [m]	Set Data Memory
Description	Each bit of the specified Data Memory is set to 1.
Operation	$[m] \leftarrow FFH$
Affected flag(s)	None
SET [m].i	Set bit of Data Memory
Description	Bit i of the specified Data Memory is set to 1.
Operation	$[m].i \leftarrow 1$
Affected flag(s)	None
SIZ [m]	Skip if increment Data Memory is 0
Description	The contents of the specified Data Memory are first incremented by 1. If the result is 0, the following instruction is skipped. As this requires the insertion of a dummy instruction while the next instruction is fetched, it is a two cycle instruction. If the result is not 0 the program proceeds with the following instruction.
Operation	$[m] \leftarrow [m] + 1$ Skip if $[m]=0$
Affected flag(s)	None
SIZA [m]	Skip if increment Data Memory is zero with result in ACC
Description	The contents of the specified Data Memory are first incremented by 1. If the result is 0, the following instruction is skipped. The result is stored in the Accumulator but the specified Data Memory contents remain unchanged. As this requires the insertion of a dummy instruction while the next instruction is fetched, it is a two cycle instruction. If the result is not 0 the program proceeds with the following instruction.
Operation	$ACC \leftarrow [m] + 1$ Skip if $ACC=0$
Affected flag(s)	None
SNZ [m].i	Skip if bit i of Data Memory is not 0
Description	If bit i of the specified Data Memory is not 0, the following instruction is skipped. As this requires the insertion of a dummy instruction while the next instruction is fetched, it is a two cycle instruction. If the result is 0 the program proceeds with the following instruction.
Operation	Skip if $[m].i \neq 0$
Affected flag(s)	None
SUB A,[m]	Subtract Data Memory from ACC
Description	The specified Data Memory is subtracted from the contents of the Accumulator. The result is stored in the Accumulator. Note that if the result of subtraction is negative, the C flag will be cleared to 0, otherwise if the result is positive or zero, the C flag will be set to 1.
Operation	$ACC \leftarrow ACC - [m]$
Affected flag(s)	OV, Z, AC, C

SUBM A,[m]	Subtract Data Memory from ACC with result in Data Memory
Description	The specified Data Memory is subtracted from the contents of the Accumulator. The result is stored in the Data Memory. Note that if the result of subtraction is negative, the C flag will be cleared to 0, otherwise if the result is positive or zero, the C flag will be set to 1.
Operation	$[m] \leftarrow ACC - [m]$
Affected flag(s)	OV, Z, AC, C
SUB A,x	Subtract immediate data from ACC
Description	The immediate data specified by the code is subtracted from the contents of the Accumulator. The result is stored in the Accumulator. Note that if the result of subtraction is negative, the C flag will be cleared to 0, otherwise if the result is positive or zero, the C flag will be set to 1.
Operation	$ACC \leftarrow ACC - x$
Affected flag(s)	OV, Z, AC, C
SWAP [m]	Swap nibbles of Data Memory
Description	The low-order and high-order nibbles of the specified Data Memory are interchanged.
Operation	$[m].3 \sim [m].0 \leftrightarrow [m].7 \sim [m].4$
Affected flag(s)	None
SWAPA [m]	Swap nibbles of Data Memory with result in ACC
Description	The low-order and high-order nibbles of the specified Data Memory are interchanged. The result is stored in the Accumulator. The contents of the Data Memory remain unchanged.
Operation	$ACC.3 \sim ACC.0 \leftarrow [m].7 \sim [m].4$ $ACC.7 \sim ACC.4 \leftarrow [m].3 \sim [m].0$
Affected flag(s)	None
SZ [m]	Skip if Data Memory is 0
Description	If the contents of the specified Data Memory is 0, the following instruction is skipped. As this requires the insertion of a dummy instruction while the next instruction is fetched, it is a two cycle instruction. If the result is not 0 the program proceeds with the following instruction.
Operation	Skip if $[m]=0$
Affected flag(s)	None
SZA [m]	Skip if Data Memory is 0 with data movement to ACC
Description	The contents of the specified Data Memory are copied to the Accumulator. If the value is zero, the following instruction is skipped. As this requires the insertion of a dummy instruction while the next instruction is fetched, it is a two cycle instruction. If the result is not 0 the program proceeds with the following instruction.
Operation	$ACC \leftarrow [m]$ Skip if $[m]=0$
Affected flag(s)	None
SZ [m].i	Skip if bit i of Data Memory is 0
Description	If bit i of the specified Data Memory is 0, the following instruction is skipped. As this requires the insertion of a dummy instruction while the next instruction is fetched, it is a two cycle instruction. If the result is not 0, the program proceeds with the following instruction.
Operation	Skip if $[m].i=0$
Affected flag(s)	None

TABRD [m]	Read table (current page) to TBLH and Data Memory
Description	The low byte of the program code (current page) addressed by the table pointer (TBLP) is moved to the specified Data Memory and the high byte moved to TBLH.
Operation	[m] ← program code (low byte) TBLH ← program code (high byte)
Affected flag(s)	None
TABRDL [m]	Read table (last page) to TBLH and Data Memory
Description	The low byte of the program code (last page) addressed by the table pointer (TBLP) is moved to the specified Data Memory and the high byte moved to TBLH.
Operation	[m] ← program code (low byte) TBLH ← program code (high byte)
Affected flag(s)	None
XOR A,[m]	Logical XOR Data Memory to ACC
Description	Data in the Accumulator and the specified Data Memory perform a bitwise logical XOR operation. The result is stored in the Accumulator.
Operation	ACC ← ACC "XOR" [m]
Affected flag(s)	Z
XORM A,[m]	Logical XOR ACC to Data Memory
Description	Data in the specified Data Memory and the Accumulator perform a bitwise logical XOR operation. The result is stored in the Data Memory.
Operation	[m] ← ACC "XOR" [m]
Affected flag(s)	Z
XOR A,x	Logical XOR immediate data to ACC
Description	Data in the Accumulator and the specified immediate data perform a bitwise logical XOR operation. The result is stored in the Accumulator.
Operation	ACC ← ACC "XOR" x
Affected flag(s)	Z

Package Information

Note that the package information provided here is for consultation purposes only. As this information may be updated at regular intervals users are reminded to consult the [Holtek website](#) for the latest version of the [Package/Carton Information](#).

Additional supplementary information with regard to packaging is listed below. Click on the relevant section to be transferred to the relevant website page.

- [Package Information \(include Outline Dimensions, Product Tape and Reel Specifications\)](#)
- [The Operation Instruction of Packing Materials](#)
- [Carton information](#)

16-pin NSOP (150mil) Outline Dimensions

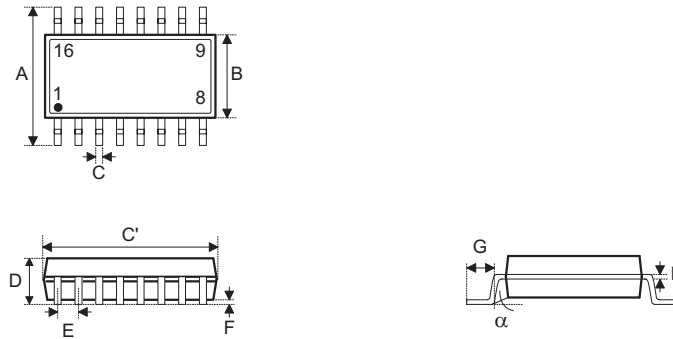

Symbol	Dimensions in inch		
	Min.	Nom.	Max.
A	—	0.236 BSC	—
B	—	0.154 BSC	—
C	0.012	—	0.020
C'	—	0.390 BSC	—
D	—	—	0.069
E	—	0.050 BSC	—
F	0.004	—	0.010
G	0.016	—	0.050
H	0.004	—	0.010
α	0°	—	8°

Symbol	Dimensions in mm		
	Min.	Nom.	Max.
A	—	6.000 BSC	—
B	—	3.900 BSC	—
C	0.31	—	0.51
C'	—	9.900 BSC	—
D	—	—	1.75
E	—	1.270 BSC	—
F	0.10	—	0.25
G	0.40	—	1.27
H	0.10	—	0.25
α	0°	—	8°

20-pin SSOP (150mil) Outline Dimensions

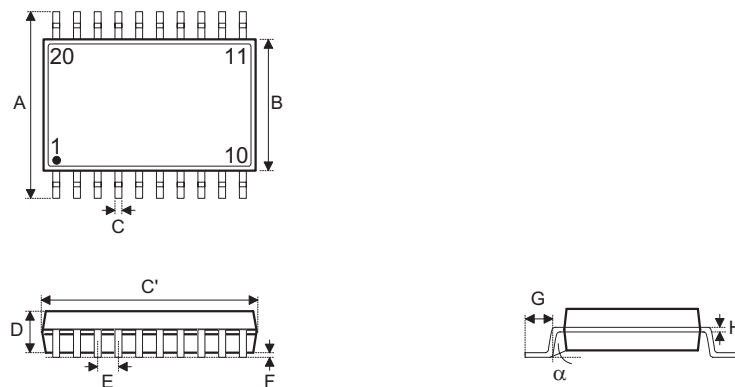

Symbol	Dimensions in inch		
	Min.	Nom.	Max.
A	—	0.236 BSC	—
B	—	0.154 BSC	—
C	0.008	—	0.012
C'	—	0.341 BSC	—
D	—	—	0.069
E	—	0.025 BSC	—
F	0.004	—	0.0098
G	0.016	—	0.05
H	0.004	—	0.01
α	0°	—	8°

Symbol	Dimensions in mm		
	Min.	Nom.	Max.
A	—	6.000 BSC	—
B	—	3.900 BSC	—
C	0.20	—	0.30
C'	—	8.660 BSC	—
D	—	—	1.75
E	—	0.635 BSC	—
F	0.10	—	0.25
G	0.41	—	1.27
H	0.10	—	0.25
α	0°	—	8°

Copyright© 2016 by HOLTEK SEMICONDUCTOR INC.

The information appearing in this Data Sheet is believed to be accurate at the time of publication. However, Holtek assumes no responsibility arising from the use of the specifications described. The applications mentioned herein are used solely for the purpose of illustration and Holtek makes no warranty or representation that such applications will be suitable without further modification, nor recommends the use of its products for application that may present a risk to human life due to malfunction or otherwise. Holtek's products are not authorized for use as critical components in life support devices or systems. Holtek reserves the right to alter its products without prior notification. For the most up-to-date information, please visit our web site at <http://www.holtek.com>.